

Modifications for the KENWOOD

created 28-03-2002 from www.mods.dk

- (AT-50)** [AT-50 Blows ACCY fuse in TS-50S](#) English language
- (AT-50)** [AT-50 Blows ACCY fuse in TS-50S \(Part 2\)](#) English language
- (AT-50)** [AT-50 Mechanical stability](#) English language
- (DG-1)** [Service Note on DG-1](#) English language
- (DG-1)** [DG-1 Standard service procedure](#) English language
- (DG-5)** [Repairing DG-5](#) English language
- (DG-5)** [Reparing DG-5](#) English language
- (DG-5)** [Theory of Operation](#) English language
- (DG-5)** [DG-5 Standard service procedure](#) English language
- (GENERAL)** [KENWOOD TH-series HT TNC Interconnection](#) English language
- (GENERAL)** [Service manual rx section level diagrams](#) English language
- (GENERAL)** [How to build COMPUTER INTERFACE](#) English language
- (GENERAL)** [How to remove Display-Scratches](#) English language
- (GENERAL)** [Kenwood 4 pin microphone connections to TNC](#) English language
- (GENERAL)** [Kenwood 6 pin microphone connections to TNC](#) English language
- (GENERAL)** [Kenwood 8 pin microphone connections to TNC](#) English language
- (GENERAL)** [Kenwod mic modification](#) English language
- (GENERAL)** [Optional narrow ceramic filters](#) English language
- (GENERAL)** [VFO-230 Operation on 240V AC](#) English language
- (GENERAL)** [Service manual TX level diagrams](#) English language
- (GENERAL)** [Power module heat sink compound](#) English language
- (GENERAL)** [The MIC pin configurations](#) English language
- (MC-44)** [MC-44DM Microphone audio improvements](#) English language
- (MC-44)** [MC44/MC44DM Intermittent modulation](#) English language
- (MC-45)** [Making the MC-45 Microphone work on the TR-7400A](#) English language
- (MC-46)** [MC-46 DTMF Mic. With older equipment](#) English language
- (MC-48)** [MC-48B Mic element change](#) English language
- (MC-50)** [VOX-3 Sensitivity and Delay](#) English language
- (MC-55)** [MC-55 Change in mic element \(T91-0328-08\)](#) English language
- (MC-60)** [Modifikation MC-60](#) German language
- (MC-60)** [Kenwood MC-60 Microphone Mod \(Connect to ICOM IC-746\)](#) English language
- (MC-60)** [Remove RFI in the MC60](#) English language
- (MC-85)** [Mod for MC-85 MIC and RC-1A phone](#) English language
- (MC-85)** [Connect Kenwood MC-85 to Yaesu FT-100](#) English language
- (PS-430)** [No protection on Powersupply](#) English language
- (PS-430)** [PS-430 Voltage increase with TH-205/215](#) English language
- (PS-50)** [PS-50 Improved Voltage Surge Protection](#) English language
- (QR-666)** [QR-666 VFO stability](#) English language
- (R-1000)** [Kenwood R-1000 muting](#) English language
- (R-1000)** [R-1000 AGC, AM bandwidth changes](#) English language
- (R-1000)** [R-1000 RF attenuator 10 dB step option](#) English language
- (R-5000)** [Kenwood R5000 Modification Notes](#) English language
- (R-5000)** [R-5000 No Freq. Change thru Computer Interface](#) English language
- (R-5000)** [Increase the MW sensitivity for R-5000](#) English language
- (R-599)** [Service Notes on R-599A/D](#) English language
- (R-599)** [Removing CB Band from R-599A/D](#) English language
- (RC-10)** [RC-10 Hang up time/timeout timer settings](#) English language
- (RC-10)** [RC-10 Alternator noise](#) English language

(RC-1A) [Mod for MC-85 MIC and RC-1A phone](#) English language

(RM-76) [RM-76 Battery Back Up Power](#) English language

(RM-76) [RM-76 Microprocessor failure](#) English language

(SM-220) [SM-220 Shield Installation](#) English language

(SM-220) [Feedback Between Pan display and IF Out](#) English language

(SM-230) [SM-230 Bandscope attenuator](#) English language

(SM-230) [SM-230 RTTY cross pattern attenuation](#) English language

(SMC-34) [SMC-34 Distorted/muffled transmit audio](#) English language

(T-599) [Service Notes on T-599A/D](#) English language

(T-599) [Reducing 120Hz hum in T-599D](#) English language

(TF-541) [TF541E & 9k6 so gehts](#) German language

(TH-205) [TH-205/215 Protection Fuse Replacement](#) English language

(TH-205) [144 - 165 TX/RX mod for the TH-205](#) English language

(TH-205) [Expanding TX and RX for Kenwood TH-205](#) English language

(TH-205) [TH-205/215/415 Volume/squelch control improvement](#) English language

(TH-205) [TH-205 Signal-To-Noise ratio improvement](#) English language

(TH-205) [TH-205/215/315/415 PTT knob installation procedure](#) English language

(TH-215) [TH-205/215 Protection Fuse Replacement](#) English language

(TH-215) [TH-215A to TNC](#) English language

(TH-215) [KENWOOD TH-215A out-of-band mod](#) English language

(TH-215) [A TH215 no audio fix](#) English language

(TH-215) [TH-215 jumper modification](#) English language

(TH-215) [TH-205/215/415 Volume/squelch control improvement](#) English language

(TH-215) [TH-215/415 TX signal-To-Noise ratio improvements](#) English language

(TH-215) [TH-205/215/315/415 PTT knob installation procedure](#) English language

(TH-215) [TH-215A handheld transceiver 12.5KHz modification](#) English language

(TH-22) [TH-22E and CLONE](#) English language

(TH-22) [TH-22AT Beyond Mars Modification](#) English language

(TH-22) [Expanding TH-22 to 136-174 MHz](#) English language

(TH-22) [KENWOOD TH-22E xpansion...WARNING](#) English language

(TH-22) [TH-22/42A/E Memory loss improvement](#) English language

(TH-225) [Kenwood TH225A modifications](#) English language

(TH-25) [TH-25AT MARS/CAP modification](#) English language

(TH-25) [KENWOOD TH-25/45 out of banad modifications](#) English language

(TH-25) [TH-25/45AT Automatic Power OFF Function](#) English language

(TH-25) [EXT TX ON THE: TH-26AT/TH-45AT/TH-75A HT's](#) English language

(TH-25) [TH-25/45 W/TSU-6 Tone alert improvements](#) English language

(TH-26) [EXT TX ON THE: TH-26AT/TH-45AT/TH-75A HT's](#) English language

(TH-26) [Expanding frequency range for the TH-26E](#) English language

(TH-26) [Expanding frequency range for the TH-26E](#) English language

(TH-26) [TH-26A Internal bridges](#) English language

(TH-2600) [Mod to open TX on the Kenwood TH-2600-a](#) English language

(TH-27) [Keyboard Mods to access AM detector and change band](#) English language

(TH-27) [TH-27A/E Low TX power](#) English language

(TH-28) [Secret function manual of the KENWOOD TH-28e/48e porto](#) English language

(TH-28) [TH28 Send memory to other radio](#) English language

(TH-28) [Accus in BT8 \(TH28/48/78\)](#) English language

(TH-28) [TH-28/48/78 Difficult battery insertion](#) English language

(TH-28) [TH-28/48A/E CTCSS tone error](#) English language

(TH-315) [TH-205/215/315/415 PTT knob installation procedure](#) English language

(TH-405) [Umbau TH-405e auf 9k6](#) German language

(TH-415) [TH-205/215/415 Volume/squelch control improvement](#) English language

- (TH-415)** [TH-215/415 TX signal-To-Noise ratio improvements](#) English language
- (TH-415)** [TH-205/215/315/415 PTT knob installation procedure](#) English language
- (TH-42)** [TH-22/42A/E Memory loss improvement](#) English language
- (TH-45)** [KENWOOD TH-25/45 out of band modifications](#) English language
- (TH-45)** [TH-45E auf 9k6](#) German language
- (TH-45)** [TH-25/45AT Automatic Power OFF Function](#) English language
- (TH-45)** [TH-25/45 W/TSU-6 Tone alert improvements](#) English language
- (TH-46)** [Extended RX/TX for TH-46](#) English language
- (TH-47)** [TH-47A Mods for ext frq](#) English language
- (TH-48)** [Secret function manual of the KENWOOD TH-28e/48e porto](#) English language
- (TH-48)** [Extended UHF TX. Also VHF/UHF/Cellular RX Modification](#) English language
- (TH-48)** [TH-28/48/78 Difficult battery insertion](#) English language
- (TH-48)** [TH-28/48A/E CTCSS tone error](#) English language
- (TH-48)** [TH-48A Microprocessor change](#) English language
- (TH-75)** [TX across entire tuning range TH-75A](#) English language
- (TH-75)** [9600 baud with the TH 75](#) English language
- (TH-75)** [TH-75A MARS/CAP modification](#) English language
- (TH-75)** [TH-75E auf 9k6](#) German language
- (TH-75)** [TH-75A No TX on VHF using a vehicle battery supply](#) English language
- (TH-75)** [TH-75A Intermittent memory loss](#) English language
- (TH-77)** [Umbauanleitung fuer das TH77e von Kenwood fuer 9600 Baud](#) German language
- (TH-77)** [Expanded RX/TX for TH-77A](#) English language
- (TH-77)** [receive AM aircraft](#) English language
- (TH-77)** [Crossband repeat](#) English language
- (TH-77)** [TH-77A PLL Unlock Override Mod](#) English language
- (TH-77)** [Pushing the TH-77A UHF receiver higher in frequency](#) English language
- (TH-77)** [TH-77A Memory loss with low battery pack](#) English language
- (TH-78)** [Basics of modifying the Kenwood TH-78a](#) English language
- (TH-78)** [Potential case design flaw](#) English language
- (TH-78)** [C-17 design flaw](#) English language
- (TH-78)** [Mutually exclusive mods](#) English language
- (TH-78)** [The beyond MARS mod](#) English language
- (TH-78)** [The CAP/MARS mod](#) English language
- (TH-78)** [The extended receive mod](#) English language
- (TH-78)** [The cross-band repeat mod](#) English language
- (TH-78)** [Toggle SHIFT button function](#) English language
- (TH-78)** [Toggle CALL button function](#) English language
- (TH-78)** [Observations on post-mod performance](#) English language
- (TH-78)** [Cloning](#) English language
- (TH-78)** [Cellular Telephones](#) English language
- (TH-78)** [Battery life on the TH-78A](#) English language
- (TH-78)** [Game Mode](#) English language
- (TH-78)** [TH-78 - antenna hints](#) English language
- (TH-78)** [9600 Baud FSK-Modifikation für das Kenwood TH-78E](#) German language
- (TH-78)** [TH78A, USA model don't have 1750 Hz](#) English language
- (TH-78)** [Crossband repeat, extended RX/TX](#) English language
- (TH-78)** [TH-78A Clone failure w/ME-1 installed](#) English language
- (TH-78)** [TH-78A Call channel tone frequency error \(Revised\)](#) English language
- (TH-78)** [TH-78A/E Left encoder inoperative](#) English language
- (TH-78)** [TH-28/48/78 Difficult battery insertion](#) English language
- (TH-78)** [TH-78A Microprocessor change](#) English language
- (TH-79)** [TH-79 clone memory contense of two radio](#) English language

- (TH-79)** [TH-79A extended RX and TX range for new radio](#) English language
- (TH-79)** [TH-79A Wide Band Modification](#) English language
- (TH-79)** [MARS/CAP modification for the new Kenwood TH-79A](#) English language
- (TH-79)** [Hidden options TH-79](#) English language
- (TH-79)** [TH-79 WIDEBAND-RX ONLY](#) English language
- (TH-79)** [Umbau TH79e auf 9k6](#) German language
- (TH-79)** [Kenwood TH-79A\(D\) Review](#) English language
- (TH-79)** [Remote Base Operation with Kenwood 732/733](#) English language
- (TH-79)** [Post Modification Spec Sheet](#) English language
- (TH-79)** [Cross Band Repeat](#) English language
- (TH-79)** [TH-79 Save function & packet!](#) English language
- (TH-79)** [TH-79 FAQ 3.5 by DG8NGN](#) English language
- (TH-79)** [DTMF-based message translator](#) English language
- (TH-79)** [TH-79 FAQ 3.5 by DG8NGN](#) German language
- (TH-D7A)** [Kenwood TH-D7a TX band modification](#) English language
- (TH-D7A)** [TH-D7A Firmware upgrade](#) English language
- (TH-D7A)** [TH-D7A/E Conversion Document](#) English language
- (TH-D7a)** [Memory Control Program for TH-D7 V. 0.01 Beta](#) English language
- (TH-D7E)** [TH-D7E extended RX](#) English language
- (TH-D7E)** [Changes a TH-D7E into a TH-D7A and enables the SKY-COMMAND option](#) English language
- (TH-D7E)** [TH-D7A/E Conversion Document](#) English language
- (TH-D7E)** [Memory Control Program for TH-D7 v. 0.01 Beta](#) English language
- (TH-F6)** [Extended transmit for TH-F6A/E](#) English language
- (TH-F6)** [PC-programming cable for Kenwood TH-G71A / TH-F6A](#) English language
- (TH-F7)** [Extended TX Mods by G1IVG](#) English language
- (TH-G71A)** [TH-G71A Beyond Mars modification](#) English language
- (TH-G71A)** [PC-programming cable for Kenwood TH-G71A / TH-F6A](#) English language
- (TH-G71E)** [TH-G71E repeater shift](#) English language
- (TH-G71E)** [Il nuovo KENWOOD TH-G71E by HB9OAE](#) Other language
- (TK-240)** [Kenwood TK-240 programmed with 16 channels](#) English language
- (TK-270)** [TK370/270 high-band h/t radio instructions](#) English language
- (TK-340)** [TK340 Programming Information](#) English language
- (TK-370)** [TK370/270 high-band h/t radio instructions](#) English language
- (TK-705)** [Revised TK-705D & TK-805D programming](#) English language
- (TK-760)** [Programming Kenwood TK-760 mobile](#) English language
- (TK-768)** [Programmin a TK-768 or TK-768H](#) English language
- (TK-805)** [Kenwood TK-805D programming](#) English language
- (TK-805)** [Revised TK-705D & TK-805D programming](#) English language
- (TM-201)** [TM-201/401 Increased TX Audio](#) English language
- (TM-211)** [TM-211 out of band modifications](#) English language
- (TM-211)** [Extended range!](#) English language
- (TM-221)** [General Coverage XMIT - TM-221/A](#) English language
- (TM-221)** [TM-221A Final Module Hints](#) English language
- (TM-221)** [TM-221A No TX in High Power Due to Voltage Drop](#) English language
- (TM-221)** [Extended range](#) English language
- (TM-231)** [TM-231A MARS/CAP modification](#) English language
- (TM-231)** [TM-231A Out of band](#) English language
- (TM-231)** [TM-231 Low Mic Audio Fix](#) English language
- (TM-231)** [TM-231A Intermittent memory loss](#) English language
- (TM-241)** [TM-241A RX/TX mods](#) English language
- (TM-251)** [This is the wide-banding modification for the Kenwood TM-251E](#) English language
- (TM-2530)** [TM-2530/2550/2570 MARS/CAP](#) English language

(**TM-255**) [Solution 9k6 TM255/455](#) English language
(**TM-255**) [Mods for the Kenwood TM-255E](#) English language
(**TM-2550**) [TM-2530/2550/2570 MARS/CAP](#) English language
(**TM-2550**) [TM-2550 DCL Call Sign Data](#) English language
(**TM-2570**) [TM-2530/2550/2570 MARS/CAP](#) English language
(**TM-2570**) [TM-2570 Low TX Power Output](#) English language
(**TM-261**) [TM-261a Extended frequency](#) English language
(**TM-261**) [Kenwood TM-261a 136-174 MHz transmitt modification](#) English language
(**TM-261**) [TM-261 Mike Button](#) English language
(**TM-321**) [TM-321A Mars/cap mod](#) English language
(**TM-321**) [TM-321A Weak mic audio fix](#) English language
(**TM-321**) [TM-321A Mod to Squelch thw audio at mic pin 6](#) English language
(**TM-321**) [Packet mod for TM-321](#) English language
(**TM-321**) [TM-321A Loss of TX audio with MC-48B](#) English language
(**TM-3530**) [TM-3530 Noisy transmit](#) English language
(**TM-3530**) [Extended TX for the Kenwood TM 3530a 220MHz radio](#) English language
(**TM-401**) [Umbau TM401A auf 9600bd und mehr](#) German language
(**TM-401**) [TM-201/401 Increased TX Audio](#) English language
(**TM-411**) [TM-411 Low/No Receiver Sensitivity](#) English language
(**TM-411**) [TM-411A Microprocessor change](#) English language
(**TM-421**) [TM-421ES fuer 9600 Baud](#) German language
(**TM-421**) [TM-421a TX mod](#) English language
(**TM-431**) [TM-431A Wide Band Transmit Modification](#) English language
(**TM-431**) [9600 mod for TM431A](#) English language
(**TM-431**) [TM-431E fuer 9600 Baud](#) German language
(**TM-431**) [Measure deviation using TM231,431,531](#) English language
(**TM-441**) [TM-441E Umbau 9k6](#) German language
(**TM-441**) [QRG mod for Kenwood TM-441E](#) German language
(**TM-451**) [Frequency expansion for the Kenwood TM 451 E](#) English language
(**TM-451**) [TM-451E Low Power Mod](#) English language
(**TM-455**) [Solution 9k6 TM255/455](#) English language
(**TM-455**) [TM-455A/E Change in pin diode](#) English language
(**TM-461**) [Expand the TX to 420 to 450MHz](#) English language
(**TM-531**) [TM-531 & 9600 Baud](#) English language
(**TM-531**) [Measure deviation using TM231,431,531](#) English language
(**TM-531**) [TM-531A 20 MHz offset modification](#) English language
(**TM-621**) [TM-621 to 9600 baud](#) English language
(**TM-621**) [Modulations mod for TM-261](#) English language
(**TM-631**) [TM-631/731A Memory loss modification](#) English language
(**TM-631**) [TM-731A/631A Final board C17 change](#) English language
(**TM-642**) [TM-642/742/942A Microprocessor change](#) English language
(**TM-642**) [Microprocessor Change, TM642/742/942](#) English language
(**TM-701**) [TM-701A repeater cross-band modification](#) English language
(**TM-701**) [TM-701 transmitting and receiving from 136-175MHz](#) English language
(**TM-701**) [TM-701A Intermittent memory loss](#) English language
(**TM-702**) [KENWOOD TM-702 to 9600 baud](#) English language
(**TM-702**) [KENWOOD TM-702E & mods. for function trsponder](#) English language
(**TM-702**) [Ecco una nuova modifica per il Kenwood TM702](#) Other language
(**TM-702**) [Extended RX and TX for TM-702E](#) English language
(**TM-721**) [Modification from Kenwood on the TM-721A for adding cross-band](#) English language
(**TM-721**) [Time-out timer](#) English language
(**TM-721**) [Tuning the 721 UHF for 460 MHz](#) English language

(**TM-721**) [New LCD Readout for Kenwood TM-721A](#) English language

(**TM-721**) [IC-721E RX/TX mod 142 - 152 MHz mods](#) English language

(**TM-721**) [TM-721A wide band mod](#) English language

(**TM-721**) [The programming resistors do the following](#) English language

(**TM-721**) [Modifying the Kenwood TM-721A for Extended UHF Coverage](#) English language

(**TM-721**) [TM-721A Low/No VHF Transmit Power](#) English language

(**TM-721**) [TM-721A for 9600 baud](#) English language

(**TM-721**) [TM-721 cross-band repeater \(another\)](#) English language

(**TM-721**) [TM-721A Microcomputer Lock-up](#) English language

(**TM-721**) [TM-721A S-Meter deflection due to pulse noise](#) English language

(**TM-721**) [TM-721A AF pa white noise with squelch on](#) English language

(**TM-731**) [TM-731 frequency and cross band repeater](#) English language

(**TM-731**) [TM731 & 9600 Bps](#) English language

(**TM-731**) [TM-731 fuer 9600 Baud](#) German language

(**TM-731**) [TM-731A Hooking to TNCS](#) English language

(**TM-731**) [Kenwood Cross Band Repeat: How to USE it](#) English language

(**TM-731**) [Kenwood TM-731A firmware bug](#) English language

(**TM-731**) [TM-631/731A Memory loss modification](#) English language

(**TM-731**) [TM-731A/631A Final board C17 change](#) English language

(**TM-731**) [TM-731e Frequenz erweiterung](#) German language

(**TM-732**) [AIR CLONING \(Does not work in K1 or E1 Mod modes\)](#) English language

(**TM-732**) [PAGING ANSWERBACK \(Does not work in K1 or E1 Mod modes\)](#) English language

(**TM-732**) [Memory recovery](#) English language

(**TM-732**) [Subjective Impressions](#) English language

(**TM-732**) [800 MHZ RECEIVE](#) English language

(**TM-732**) [Hard-wire cloning](#) English language

(**TM-732**) [TM-732E fuer 9600](#) German language

(**TM-732**) [TM-732 gets hot](#) English language

(**TM-732**) [AM detector control](#) English language

(**TM-732**) [Extended RX & TX Mods](#) English language

(**TM-732**) [9600 baud UHF packet radio mods](#) English language

(**TM-732**) [TM-732A 2 Meter transmit interference on 70 CM](#) English language

(**TM-732**) [TM-732A/E Change in chip fuse rating](#) English language

(**TM-732**) [TM-732A Low cross-band repeater audio](#) English language

(**TM-732**) [TM-732A/E Noise at squelch ON/OFF](#) English language

(**TM-732**) [TM-732A S-meter squelch scan stop improvement](#) English language

(**TM-732**) [TM-732A Protection of Q201 in 430 MHz unit](#) English language

(**TM-732**) [TM-732A Control PC Board B+ foil damage](#) English language

(**TM-732**) [TM-732A/E APC circuit improvement](#) English language

(**TM-732**) [TM-732 partial display or no power up](#) English language

(**TM-733**) [TM733 with 2 antenna-sockets](#) English language

(**TM-733**) [TM733 and 9k6 Bps](#) English language

(**TM-733**) [TM733 & 9K6](#) English language

(**TM-733**) [TM-733E MOD 9k6 english](#) English language

(**TM-733**) [MODS OF KENWOOD TM-733 for Japanese version](#) English language

(**TM-733**) [TM-733A Quick Reference Guide](#) English language

(**TM-733**) [Extended RF Modifications](#) English language

(**TM-733**) [DTMF Remote via Microphone](#) English language

(**TM-733**) [Cross Band Repeating](#) English language

(**TM-733**) [DTMF Paging and Squelch](#) English language

(**TM-733**) [Wireless Cloning](#) English language

(**TM-733**) [TM-733A PL Tone Distortion](#) English language

(**TM-733**) [External DTMF Remote Control](#) English language
(**TM-733**) [TM-733 data pinouts descriptions](#) English language
(**TM-733**) [TM-733A PL tone bleed through](#) English language
(**TM-733**) [TM-733 quick operation guide](#) English language
(**TM-741**) [Umbau des TRX Kenwood TM-741 E fuer 9600bd](#) German language
(**TM-741**) [TM-741ATE Frequency enion](#) English language
(**TM-741**) [TM-741a/e AM recleppion with 28 and 50 mhz unit](#) English language
(**TM-741**) [TM-741 A/E 900 MHz band receptton with 430 MHz unit](#) English language
(**TM-741**) [TM-741A/E memory channel doubling](#) English language
(**TM-741**) [TM-741A/E extended paging functions](#) English language
(**TM-741**) [TM-741/E DTE DISPLAY Format](#) English language
(**TM-741**) [TM-741A/E DC ERDISPLAY](#) English language
(**TM-741**) [TM 741A/E headlight linkage dimmer](#) English language
(**TM-741**) [TM 741A/E game mode](#) English language
(**TM-741**) [Kenwood TM-741a GAME Dox](#) English language
(**TM-741**) [Display test](#) English language
(**TM-741**) [Hearing birdies in the 440 MHz position](#) English language
(**TM-741**) [TM-741A/E repeater modification \(transponder functions\)](#) English language
(**TM-741**) [TM-741a All-Band mod for new Kenwood Tri-Bander](#) English language
(**TM-742**) [Microprocessor Change, TM642/742/942](#) English language
(**TM-742**) [Modification of TM-742 & 942](#) English language
(**TM-742**) [Extended frequency for TM-742E](#) English language
(**TM-742**) [Fan Delay time setting](#) English language
(**TM-742**) [Wireless remote control with DTMF handheld transceiver](#) English language
(**TM-742**) [CHANGE YOUR TM-742E TO A TM-942E \(who don't exist on the market\)](#) English language
(**TM-742**) [TM-742/942 Beyond Mars/CAP Mod. Guide](#) English language
(**TM-742**) [TM-742/942 28 MHz/50 MHz RC TX failure](#) English language
(**TM-742**) [TM-742/942A Microprocessor change](#) English language
(**TM-742**) [TM-642/742/942A Microprocessor change](#) English language
(**TM-742**) [TM-742 Control Unit X53-346X-XX **B/2** TX Mod](#) English language
(**TM-941**) [Kenwood TM-941A undocumented feature](#) English language
(**TM-942**) [Microprocessor Change, TM642/742/942](#) English language
(**TM-942**) [Modification of TM-742 & 942](#) English language
(**TM-942**) [TM-742/942 Beyond Mars/CAP Mod. Guide](#) English language
(**TM-942**) [TM-742/942 28 MHz/50 MHz RC TX failure](#) English language
(**TM-942**) [TM-742/942A Microprocessor change](#) English language
(**TM-942**) [TM-642/742/942A Microprocessor change](#) English language
(**TM-D700**) [KENWOOD TM-D700A Extended TX MOD \(easy 3 steps\)](#) English language
(**TM-D700**) [TM-D700 CAP/MARS](#) English language
(**TM-D700**) [Kenwood TM-D700A service mode](#) English language
(**TM-D700**) [TM-D700A/E Cross band repeat](#) English language
(**TM-D700**) [Repeater functions. U.S.A. / Canada only](#) English language
(**TM-D700**) [Enable Crossband Repeater Function TM-D700E Version](#) English language
(**TM-D700**) [Update for the Kenwood TM-D700A/E Deviation level](#) English language
(**TM-D700**) [Demonstration mode for TM-D700](#) English language
(**TM-D700**) [TM-D700A MC53-DM MIC PTT Spring tension MOD](#) English language
(**TM-D700**) [TM-D700E Sky command/Remote enable](#) English language
(**TM-G707**) [Extended RX and TX for Kenwood TM-G707](#) English language
(**TM-G707**) [Extended RX MOD for Kenwood TM-G707A](#) English language
(**TM-G707**) [Low Audio Fix for Kenwood TM-G707](#) English language
(**TM-V7A**) [Expanding the Kenwood TM-V7: A & E versions](#) English language
(**TM-V7A**) [PG-4S programmer cable for the TM-V7x](#) German language

(TM-V7A) [TM-V7A Ext. remote control operation](#) English language
(TM-V7A) [Conversion document](#) English language
(TM-V7A) [Computer interface for TM-V7A&E](#) English language
(TM-V7E) [TM-V7E mike & PF1 <> PF4 \(1750hz\)](#) English language
(TM-V7E) [Expanding the Kenwood TM-V7: A & E versions](#) English language
(TM-V7E) [PG-4S programmer cable for the TM-V7x](#) German language
(TM-V7E) [Expanded RX/TX and crossband repeater](#) English language
(TM-V7E) [Conversion document](#) English language
(TM-V7E) [Computer interface for TM-V7A&E](#) English language
(TR-2200) [Service notes on TR-2200A](#) English language
(TR-2200) [Adapting the TR-2200A antenna to early Trio and Drake Portables.](#) English language
(TR-2400) [TR-2400 Volume Control Replacement](#) English language
(TR-2400) [TR-2400 Battery Charger Failure](#) English language
(TR-2400) [Speaker Mic for TR-2400](#) English language
(TR-2400) [TR-2400 Tone Encoder RFI](#) English language
(TR-2400) [TR-2400 Unwanted Noise: Tone or burst at TX](#) English language
(TR-2400) [TR-2400 Display or Keyboard trouble](#) English language
(TR-2400) [TR-2400 RX low, Intermittent, or distorted](#) English language
(TR-2400) [TR-2400 Scratchy TX](#) English language
(TR-2400) [TR-2400 Optional charge input protection](#) English language
(TR-2400) [TR-2400 Offset failure](#) English language
(TR-2400) [TR-2400 unlock](#) English language
(TR-2400) [TR-2400 pulse noise](#) English language
(TR-2400) [TR-2400 TX noise](#) English language
(TR-2500) [TR-2500/3500 dip switch setting](#) English language
(TR-2500) [TR-2500 RX IMD Improvement](#) English language
(TR-2600) [Extended frequency TR-2600A](#) English language
(TR-2600) [TR-2600A PLL Unlock Troubleshooting](#) English language
(TR-2600) [How to fix TR-2600 keypad](#) English language
(TR-2600) [TR-2600A PLL unlock](#) English language
(TR-3500) [TR-2500/3500 dip switch setting](#) English language
(TR-3500) [Extended frequency TR-2600A](#) English language
(TR-7200) [Service notes on TR-7200A](#) English language
(TR-7400) [Service Notes on TR-7400A](#) English language
(TR-7400) [Arcing in TR-7400A final section](#) English language
(TR-7400) [Changes in PO Unit of the TR-7400A](#) English language
(TR-7400) [Making meter lamp in TR-7400A last longer](#) English language
(TR-751) [TR851E & TR751E with 9600](#) English language
(TR-751) [TR-751A out of band mod](#) English language
(TR-751) [Kenwood TR-751 mod sheet](#) English language
(TR-7600) [Alternator Whine, TR-7600/7625](#) English language
(TR-7600) [Correcting Frequency Difference Between RM-76 and TR-7600/TR-7625](#) English language
(TR-7600) [TR-7600/7625 Audio tone on TX](#) English language
(TR-7600) [TR-7600/7625 Optional ceramic filter](#) English language
(TR-7600) [TR-7600, TR-7625 Battery Memory Backup](#) English language
(TR-7625) [Alternator Whine, TR-7600/7625](#) English language
(TR-7625) [TR-7625 Intermittent TX](#) English language
(TR-7625) [Correcting Frequency Difference Between RM-76 and TR-7600/TR-7625](#) English language
(TR-7625) [TR-7600/7625 Audio tone on TX](#) English language
(TR-7625) [TR-7600/7625 Optional ceramic filter](#) English language
(TR-7625) [TR-7600, TR-7625 Battery Memory Backup](#) English language
(TR-7625) [TR-7625 Final module replacement](#) English language

(TR-7625) [TR-7625 Hybrid amplifier module substitution](#) English language
(TR-7730) [TR-7730 Transmitter Freq Response, Voice or DTMF](#) English language
(TR-7800) [TR-7800 Loss of Memory](#) English language
(TR-7800) [TR-7800/TR-9000 Optional Ceramic Filters](#) English language
(TR-7800) [TR-7800 Tone pad conversion for 4th column function](#) English language
(TR-7800) [TR-7800 Pulse noise](#) English language
(TR-7800) [TR-7800 Optional continuous charge for internal batteries](#) English language
(TR-7800) [Memory Channel 7 Indicator Erratic](#) English language
(TR-7800) [TR-7800, TR-7850 Memory Improvements](#) English language
(TR-7850) [TR-7850 RF LED Meter](#) English language
(TR-7850) [Memory Channel 7 Indicator Erratic](#) English language
(TR-7850) [TR-7800, TR-7850 Memory Improvements](#) English language
(TR-7900) [TR-7800/TR-9000 Optional Ceramic Filters](#) English language
(TR-7930) [TR-7930 info](#) English language
(TR-7930) [TR-7930/7950 transceiver for packet/rtty operation](#) English language
(TR-7930) [TR-7950/30 RX Interference](#) English language
(TR-7930) [TR-7850/30 RX interference](#) English language
(TR-7930) [Kenwood TR-7930 Udvidet TX/RX](#) Danish language
(TR-7950) [TR-7950 PA module mod](#) English language
(TR-7950) [TR-7930/7950 transceiver for packet/rtty operation](#) English language
(TR-7950) [TR-7950 screwup on the power-output](#) English language
(TR-7950) [TR-7950/30 RX Interference](#) English language
(TR-7950) [TR-7850/30 RX interference](#) English language
(TR-8300) [TR-8300 Alignment](#) English language
(TR-8400) [TR-8400 auf 9k6](#) German language
(TR-8400) [TR-8400 Transmit Delay Time](#) English language
(TR-8400) [TR-8400 Transmitter Freq Response, Voice or DTMF](#) English language
(TR-8400) [TR-8400 Sub-audible Encode Installation](#) English language
(TR-8400) [TR-8400 RX internal spurious signals](#) English language
(TR-851) [TR851E & TR751E with 9600](#) English language
(TR-851) [TR851 & 9600 Bps](#) English language
(TR-851) [Umbau TR-851E > 9600Bd](#) German language
(TR-9000) [TR-9200/TR-9000 Optional Ceramic Filters](#) English language
(TR-9000) [TR-9000 CW, SSB TX instability](#) English language
(TR-9000) [TR-9000 TX pulse noise in SSB mode](#) English language
(TR-9000) [TR-9000 Transmitter Side Carrier Balance](#) English language
(TR-9000) [TR-9000 Temperature Stability Improvement](#) English language
(TR-9130) [TR-9130 Low Drive Level](#) English language
(TR-9200) [TR-9200/TR-9000 Optional Ceramic Filters](#) English language
(TR-9250) [TR-9250 RF LED Meter](#) English language
(TR-9350) [TR-9350/30 RX Interference](#) English language
(TR-9500) [TR-9500 fuer 9600bd](#) German language
(TS-120) [Hum in SSB TX, TS-120S and others](#) English language
(TS-120) [TS-120S VFO Stability](#) English language
(TS-120) [TS-120S VOX operation pick-up time](#) English language
(TS-120) [TS-120S Final Transistor Replacement](#) English language
(TS-120) [TS-120S Ant Input Transformer Replacement](#) English language
(TS-120) [TS-120 Repair Notes](#) English language
(TS-120) [TS-120S Band Pass Filter Change](#) English language
(TS-120) [TS-120S TX oscillation](#) English language
(TS-120) [TS-120S Full CW output in ssb mode](#) English language
(TS-120) [TS-120V: Reduced RX current consumption](#) English language

(TS-120) [TS-120S, TS-180S phone patch terminal addition](#) English language

(TS-120) [TS-120S Final protection](#) English language

(TS-120) [TS-120S Ant input transformer replacement \(2\)](#) English language

(TS-130) [TS-130S TX oscillation](#) English language

(TS-140) [TS-140S Sidetone Mod](#) English language

(TS-140) [TS-140S Intermittent loss of TX power](#) English language

(TS-140) [Broadcast Sensitivity Modification for the TS680S / 140S](#) English language

(TS-140) [TS-140S TX All Freq Mod](#) English language

(TS-140) [TS-140S Momentary transmission when VOX is turned on](#) English language

(TS-140) [Kenwood TS-140S tip](#) English language

(TS-180) [TS-180S Trouble Sheet](#) English language

(TS-180) [TS-180S Use with a Linear Amplifier](#) English language

(TS-180) [TS-180S Low Pass Filter Optional Changes](#) English language

(TS-180) [BS-8 Alignment with the TS-180S Transceiver](#) English language

(TS-180) [TS-180S CW Delay During VOX Memory Operation](#) English language

(TS-180) [TS-180S Low 40M ALC](#) English language

(TS-180) [TS-180S VFO Stability](#) English language

(TS-180) [TS-180S Increase of RX Audio Output](#) English language

(TS-180) [TS-180S IF output #2 Level Change for SM-220](#) English language

(TS-180) [TS-180S DFC hum with PS-30](#) English language

(TS-180) [TS-120S, TS-180S phone patch terminal addition](#) English language

(TS-180) [TS-180S DFC](#) English language

(TS-180) [TS-180S DFC Instability](#) English language

(TS-2000) [TS-2000 Mars/Cap Mod](#) English language

(TS-2000) [TS-2000 modification information \(TX and RX\)](#) English language

(TS-2000) [Sensitivity Kenwood TS-2000](#) English language

(TS-2000) [Firmware upgrade for TS-2000](#) English language

(TS-2000) [ARCP-2000 windows CAT software for Kenwoods TS-2000](#) English language

(TS-2400) [TS-2400 out-of-band mod](#) English language

(TS-2400) [TR-2400 Unwanted Noise: Tone or burst at TX](#) English language

(TS-2400) [TR-2400 Display or Keyboard trouble](#) English language

(TS-2400) [TR-2400 RX low, Intermittent, or distorted](#) English language

(TS-430) [TS-430S Noise blanker improvements](#) English language

(TS-430) [Kenwood ts-430 AGC mod](#) English language

(TS-430) [Transmit enable for mars/cap frq for the TS-430S](#) English language

(TS-430) [Mods for the kenwood TS430S for amtor](#) English language

(TS-430) [TS430 power fault - ANSWERS](#) English language

(TS-430) [TS-430S Intermittent PLL Unlock in FM/AM](#) English language

(TS-430) [TS-430S PLL Unlock at High Temperatures \(Revision\)](#) English language

(TS-430) [TS-430 extended coverage. Include 0-150 KHz](#) English language

(TS-430) [TS-430S Reset the microprocessor](#) English language

(TS-430) [Kenwood TS-430S, no display, no RX/TX with certain modes](#) English language

(TS-430) [No signal on the meter](#) English language

(TS-430) [TS-430S 500KHz Hetrodyne](#) English language

(TS-430) [TS-430 Notch Control](#) English language

(TS-430) [TS-430S AM Wide/Narrow filter selection](#) English language

(TS-430) [TS-430 receiver internal beat](#) English language

(TS-430) [TS-430S Low/intermittent RX](#) English language

(TS-430) [Circuit Improvements for the TS-430S](#) English language

(TS-430) [Some repair hints for TS-430](#) English language

(TS-430) [General coverage in transmission for the Kenwood TS-430S](#) English language

(TS-430) [TS430s low RX](#) English language

(TS-440) [TS-440S Digital Audio Modification](#) English language

(TS-440) [TS-440 Fan Temperature Modification](#) English language

(TS-440) [Possible cure for TS440 showing dots only on display](#) English language

(TS-440) [Undocumented feature](#) English language

(TS-440) [Serial interface](#) English language

(TS-440) [A few adjustments you should know](#) English language

(TS-440) [TS-440S modification to use antenna tuner](#) English language

(TS-440) [TS-440S display calibration](#) English language

(TS-440) [Connection of the KENWOOD TS440S to a DATA](#) English language

(TS-440) [Kenwood Computer Interface Instructions](#) English language

(TS-440) [TS-440S increase the power by ALC control](#) English language

(TS-440) [TS-440 with PIN-Diods](#) English language

(TS-440) [TS-440S Operation with the MC-85](#) English language

(TS-440) [TS-440S Notch filter low frequency improvements](#) English language

(TS-440) [TS-440S Protecting Q33](#) English language

(TS-440) [TS-440S Case Screws binding in the heat sink](#) English language

(TS-440) [TS-440 RX Audio Mods](#) English language

(TS-440) [TS-440S SSB Power-adjustment](#) English language

(TS-440) [TS-440S Intermittent operation](#) English language

(TS-440) [TS-440S PLL unlock due to VCO #5](#) English language

(TS-440) [TS-440S PLL unlock due to VCO #1](#) English language

(TS-440) [TS440S mod for improved receive sensitivity of 0.5 to 1.6MHz](#) English language

(TS-440) [Circuit Improvements for the TS-440S](#) English language

(TS-450) [KAM-PLUS Problems!! with TS-450 & 850](#) English language

(TS-450) [General coverage transmisson modification for the TS-450 and TS-690](#) English language

(TS-450) [TS-450S Intermittent receive fixed](#) English language

(TS-450) [TS-450,TS-850 feedback,ACC-2 Conn](#) English language

(TS-450) [TS-450 hidden functions](#) English language

(TS-450) [TS-450S and KAM Plus info](#) English language

(TS-450) [Micro-input RFI modification TS450-TS690 Kenwood](#) English language

(TS-450) [TS-450/690 Calibration cable change](#) English language

(TS-450) [TS-450/690 Distorted TX w/TNC](#) English language

(TS-450) [TS-450S TX frequency response](#) English language

(TS-450) [TS-450/690 Low mic gain w/DSP-100](#) English language

(TS-450) [TS-450S Parts change](#) English language

(TS-450) [TS-450S/690S Noisy encoder](#) English language

(TS-50) [TS50 FIX: LCD display dark](#) English language

(TS-50) [TS50<-->AT50 communication](#) English language

(TS-50) [TS-50 Power Mod for QRP](#) English language

(TS-50) [TX Coverage mod TS-50](#) English language

(TS-50) [CAT control for TS-50S](#) English language

(TS-50) [Important note to 0-30 MHz TRX mods](#) English language

(TS-50) [New version. General TX for TS-50](#) English language

(TS-50) [TS-50S Lithium battery replacement notes](#) English language

(TS-50) [TS-50S "Hello" displayed during TX](#) English language

(TS-50) [TS-50S Antenna lead wire](#) English language

(TS-50) [TS-50S Mechanical noise from final unit](#) English language

(TS-50) [TS-50 Modification Full time "Double-Zero"](#) English language

(TS-50) [TX 0-30 MHz for the new TS-50 \(May 2001\)](#) English language

(TS-50) [TS-50 High-Power-Modification](#) English language

(TS-50) [Kenwood TS-50S Wideband TX & double zero readout](#) English language

(TS-50) [TS-50S Australian Extended Tx](#) English language

- (TS-520)** [TS-520, TS-820 CW filter select control](#) English language
- (TS-520)** [DG-5 Standard Service Procedure](#) English language
- (TS-520)** [Service notes on TS-520](#) English language
- (TS-520)** [TS-520S -6v Supply Failure](#) English language
- (TS-520)** [TS-520/520S CW Frequency Shift](#) English language
- (TS-520)** [TS-520 Increased sensitivity, Better audio and Amplitude Modulation](#) English language
- (TS-520)** [Kenwood TS-520S for QRP](#) English language
- (TS-520)** [TS-520S MARS Mod for 4.0-4.6MHz](#) English language
- (TS-520)** [TS-520 Novice Operation \(75 watts\)](#) English language
- (TS-520)** [AM Broadcast interference in TS-520](#) English language
- (TS-520)** [TS-520/520S BS-5 Sweep interference](#) English language
- (TS-520)** [Adding IF output to the TS-520 and TS-520S transceivers for use with the SM-220](#) English language
- (TS-520)** [DS-2 Replaces DS-1A DC-DC Converter](#) English language
- (TS-520)** [Increase the sensitivity for 10 and 15 meter band](#) English language
- (TS-530)** [QRO Modification to TS-830S, TS-530S](#) English language
- (TS-530)** [TS-530S Low Voltage Supply Optional Improvements](#) English language
- (TS-530)** [TS-530S IF Unit Q2, Q7 Protection](#) English language
- (TS-530)** [TS-530 WARC bands](#) English language
- (TS-570)** [Problem with the memories](#) English language
- (TS-570)** [TS570D : durchg. Sendebere](#) German language
- (TS-570)** [Kenwood TS-570D MARS/CAP Modification](#) English language
- (TS-570)** [TS-570 Batteries](#) English language
- (TS-570)** [Kenwood TS-570DG MARS/CAP Modification](#) English language
- (TS-570)** [TS-570 Back-up battery current drain](#) English language
- (TS-570)** [How to find out the real version of TS570DG](#) English language
- (TS-60)** [TS-60S\(E\) extended receive](#) English language
- (TS-660)** [TS-660 Microprocessor Latchup](#) English language
- (TS-660)** [TS-660 Coverage to cover 20-33MHz and 46-55MHz](#) English language
- (TS-680)** [TS680s Squelch mods - adds squelch to all modes](#) English language
- (TS-680)** [TS-680 6 Meter power output increase](#) English language
- (TS-680)** [Broadcast Sensitivity Modification for the TS680S / 140S](#) English language
- (TS-680)** [TS680 Freq Extend mod](#) English language
- (TS-690)** [TS-690 50 MHz modulation problem solved](#) English language
- (TS-690)** [General coverage transmission modification for the TS-450 and TS-690](#) English language
- (TS-690)** [Micro-input RFI modification TS450-TS690 Kenwood](#) English language
- (TS-690)** [TS-690S 30KHz-60MHz RX](#) English language
- (TS-690)** [TS-450/690 Calibration cable change](#) English language
- (TS-690)** [TS-450/690 Distorted TX w/TNC](#) English language
- (TS-690)** [TS-450/690 Low mic gain w/DSP-100](#) English language
- (TS-690)** [TS-450S/690S Noisy encoder](#) English language
- (TS-690)** [Kenwood TS-690 30KHz-60MHz RX without modding](#) English language
- (TS-700)** [9600 and TS-700a](#) English language
- (TS-700)** [Service notes on TS-700A](#) English language
- (TS-700)** [TS-700A for Repeater operation in Europe](#) English language
- (TS-700)** [Replacement of 9V regulator IC MFC.4060 with improved MC1723CL-A](#) English language
- (TS-700)** [TS 700 CW QRG same as USB](#) English language
- (TS-700)** [Distorted mic signal for TR-7200G & TS-700](#) English language
- (TS-700)** [Put CW on USB for the Kenwood TS-700A, S, SP](#) English language
- (TS-700)** [Modifikationen für Kenwood TS-700](#) German language
- (TS-711)** [General coverage xmit - TS-711](#) English language
- (TS-711)** [9K6 baud modifications for KENWOOD TS-711 & TS-811](#) English language
- (TS-711)** [To expand coverage to 141.0 - 150.995 MHz](#) English language

- (TS-711)** [Betr.: 9600 Bd G3RUH-Modem an TS 711/811](#) German language
- (TS-711)** [IF Amp for TS-711A](#) English language
- (TS-770)** [Modification Kenwood TS-770E for 9600 baud \(G3RUH\)](#) English language
- (TS-780)** [TS-780 für 9k6 baud](#) German language
- (TS-790)** [TS-790 mods.for G3RUH/TAPR-PSK](#) English language
- (TS-790)** [TS-790A for use with the paccomm MC-NB96 G3RUH](#) English language
- (TS-790)** [TS-790 & 9600 Baud Operation \(Rev 2\)](#) English language
- (TS-790)** [UO-14 RX frequency tracking for TS-790/FT-736](#) English language
- (TS-790)** [TS-790 cross band repeater mod](#) English language
- (TS-790)** [TS-790 with serial frequency control](#) English language
- (TS-790)** [TS790E - Burned out diode](#) English language
- (TS-790)** [800MHz Recieve Mod for Kenwood TS-790](#) English language
- (TS-790)** [TS-790 SSB Power Increase](#) English language
- (TS-790)** [TS-790 A/E 9600bd via ACC4 port RX-problem](#) English language
- (TS-790)** [Kenwood TS790 ALC-modification](#) English language
- (TS-790)** [Convert TS790E to the USA TS790K and RX/TX mod](#) English language
- (TS-790)** [TS790 SSB Power Up](#) English language
- (TS-811)** [9K6 baud modifications for KENWOOD TS-711 & TS-811](#) English language
- (TS-811)** [Betr.: 9600 Bd G3RUH-Modem an TS 711/811](#) German language
- (TS-811)** [16kHz-Filter für TS-811E \(9600bd-paketierer\)](#) German language
- (TS-820)** [TS-820 Fix the problem with the display](#) English language
- (TS-820)** [New Display Tube for DG-1](#) English language
- (TS-820)** [TS-520, TS-820 CW filter select control](#) English language
- (TS-820)** [Installing AUX Band in TS-820 \(RX only\)](#) English language
- (TS-820)** [TA7201P Substitution Parts Kit](#) English language
- (TS-820)** [TS-820 Speech Processor Alignment](#) English language
- (TS-820)** [General Notes on TS-820S](#) English language
- (TS-820)** [TS-820 RIT modification](#) English language
- (TS-820)** [Microphone input attenuator for TS-820](#) English language
- (TS-820)** [General Alignment Procedure for the TS-820\(s\)](#) English language
- (TS-820)** [DS-2 Replaces DS-1A DC-DC Converter](#) English language
- (TS-830)** [Modification to TS-830S, TS-530S](#) English language
- (TS-830)** [TS-830S Frequency Shift](#) English language
- (TS-830)** [Amtor modification](#) English language
- (TS-830)** [Warc modification](#) English language
- (TS-830)** [VFO-230 fine tune mod correction](#) English language
- (TS-830)** [TS-830S Low Voltage Supply Optional Improvements](#) English language
- (TS-830)** [Kenwood TS-830 filter modification](#) English language
- (TS-830)** [TS-830S Operation on 240V AC](#) English language
- (TS-830)** [TS-830S Low voltage Supply Optional Improvements](#) English language
- (TS-830)** [TS-830S Noise Blanker Optional Improvements](#) English language
- (TS-830)** [TS-830S Transmitter "Talkback"](#) English language
- (TS-830)** [TS-830 Frequency Drift](#) English language
- (TS-830)** [TS-830S Frequency Drift - "FIX" switch](#) English language
- (TS-850)** [TS-850S observations](#) English language
- (TS-850)** [TS-850S All band transmit](#) English language
- (TS-850)** [TS-850S Broadcast Band Sensitivity](#) English language
- (TS-850)** [TS-850S Additional Front Panel Functions](#) English language
- (TS-850)** [Step by step instructions to disable the broadcast band attenuation for TS-850S](#) English language
- (TS-850)** [TS-850? ACC-2 audio problem](#) English language
- (TS-850)** [Adjustable moni. on CW, TS-850S](#) English language
- (TS-850)** [TS-850 service manual, error corection](#) English language

- (TS-850)** [TS-850S and speaker/headph](#) English language
- (TS-850)** [TS-850 and Ten-Tec Titan 425 PA](#) English language
- (TS-850)** [KAM-PLUS Problems!! with TS-450 & 850](#) English language
- (TS-850)** [TS-450,TS-850 feedback,ACC-2 Conn](#) English language
- (TS-850)** [Modification for External keying, while using the internal keyer](#) English language
- (TS-850)** [TS-850 Separate Receive Antenna Modification](#) English language
- (TS-850)** [TS-850 Separate RX antenna input mod](#) English language
- (TS-850)** [The switch box](#) English language
- (TS-850)** [Computer Interface for the TS-850, without using the IF-232 Level Converter](#) English language
- (TS-850)** [TS-850 Power Output Control](#) English language
- (TS-850)** [TS-850 Level Attenuator for DRU-2 playback audio](#) English language
- (TS-850)** [TS850 + Transverter oder Preselektor](#) German language
- (TS-850)** [TS-850S Distorted TX w/TNC connected](#) English language
- (TS-850)** [TS-850S Low/no Receive sensitivity](#) English language
- (TS-850)** [TS-850S No audio from VS-2](#) English language
- (TS-850)** [TS-850S Mixer FET change](#) English language
- (TS-850)** [TS-850S "Click noise" with NOTCH ON](#) English language
- (TS-850)** [Full transmit for the UK version of TS-850S](#) English language
- (TS-850)** [TS-850 2nd RX output mod](#) English language
- (TS-870)** [Frequency expansion for the TS-870S](#) English language
- (TS-870)** [TS870 DSP XCVR specs](#) English language
- (TS-870)** [TS-870S S-Meter pin with repeated RX/TX switching](#) English language
- (TS-870)** [TS-870S Receiver circuit changes](#) English language
- (TS-870)** [Making super radio out of TS-870](#) English language
- (TS-870)** [Kenwood TS870S - ALC-Mod.](#) English language
- (TS-870)** [TS-870 Output Power >100W](#) English language
- (TS-870)** [TS870 external receive antenna switching](#) English language
- (TS-870)** [\[CQ-Contest\] Collins Filters in Contest Rigs](#) English language
- (TS-870)** [Use TS-870 as a contest rig](#) English language
- (TS-870)** [TS-870S Service Menu Setup Tweaking v1.1 \(13 Oct 2000\)](#) English language
- (TS-930)** [TS-930S PLL Unlock](#) English language
- (TS-930)** [TS-930S Service Notes on AT-930](#) English language
- (TS-930)** [TS-930S Intermittent TX Power Output](#) English language
- (TS-930)** [Tuning Mods TM-930](#) English language
- (TS-930)** [Amtor keying mod](#) English language
- (TS-930)** [TS-930S CW Pitch Tone Shift](#) English language
- (TS-930)** [TS-930S 15 Meter Internal Beat Tone](#) English language
- (TS-930)** [TS-930S RF Feedback](#) English language
- (TS-930)** [TS-930S SSB TX Tone Quality](#) English language
- (TS-930)** [Error in the operator's manual of the DIGITAL UNIT pin](#) English language
- (TS-930)** [Incorrect AC line voltage setting](#) English language
- (TS-930)** [TS-930S CW Hetrodyne Tone](#) English language
- (TS-930)** [TS-930S Low RX sensitivity](#) English language
- (TS-930)** [TS-930S CW VBT](#) English language
- (TS-930)** [TS-930S Audio oscillation](#) English language
- (TS-930)** [TS-930S Feedback into MIC CRT](#) English language
- (TS-930)** [TS-930S ALC level drift 28 MHz CW](#) English language
- (TS-930)** [TS-930S Power Supply surge protection](#) English language
- (TS-930)** [TS-930S Noisy Power Supply Fan](#) English language
- (TS-930)** [Expanded R.F. on the Kenwood TS 930 S](#) English language
- (TS-930)** [Digital Unit through-plated hole defects and their symptoms](#) English language
- (TS-930)** [W6NL Mods for the TS-930 \(Very long\)](#) English language

- (TS-940)** [TS-940S LCD Clock Display Erratic Operation](#) English language
- (TS-940)** [TS-940S SSB Talk Power Improvement](#) English language
- (TS-940)** [TS-940S Erratic display](#) English language
- (TS-940)** [RX AUDIO](#) English language
- (TS-940)** [Amtor switching time](#) English language
- (TS-940)** [ALC time constant](#) English language
- (TS-940)** [TS-940 Mod for MARS and all band operations](#) English language
- (TS-940)** [TS-940S PLL unlock](#) English language
- (TS-940)** [TS-940S Antenna Tuner Relays](#) English language
- (TS-940)** [TS-940S PLL unlock](#) English language
- (TS-940)** [TS-940S AVR unit capacitor change](#) English language
- (TS-940)** [TS-940S AGC circuit improvements](#) English language
- (TS-940)** [TS-940S Signal to noise ratio improvement](#) English language
- (TS-940)** [TS-940S VCO carrier to noise ratio improvement](#) English language
- (TS-940)** [TS-940S Squelch switching noise](#) English language
- (TS-940)** [TS-940S MRF-485 Driver Transistor Notes](#) English language
- (TS-940)** [TS-940 PA drivers replacement](#) English language
- (TS-950)** [TS-950SD general coverage transmit mod](#) English language
- (TS-950)** [Kenwood TS-950 Power On Funktions](#) English language
- (TS-950)** [Kenwood TS-950-SDX Allows sub-rcvr to be on different band than Main receiver](#) English language
- (TS-950)** [TS-950SD Speech processor noise](#) English language
- (TS-950)** [TS-950SD N.B. Gate switching noise](#) English language
- (TS-950)** [TS-950SD Early protection with TL-922A](#) English language
- (TS-950)** [TS-950SD RX digital noise](#) English language
- (TS-950)** [TS-950SD Two second TX power delay with MONI on](#) English language
- (TS-950)** [TS-950/SD Receiver noise](#) English language
- (TS-950)** [TS-950S/SD TX image on 18.115 MHz](#) English language
- (TS-950)** [TS-950S/SD 80 meter spurious emission](#) English language
- (TS-950)** [TS-950S Final bias circuit change](#) English language
- (TS-950)** [TS-950S Rear panel cooling fan](#) English language
- (TS-950)** [TS-950SDX Mode switching](#) English language
- (TS-950)** [TS-950SDX No beep in headphones](#) English language
- (TS-950)** [TS-950SDX Distorted DRU-2 TX audio](#) English language
- (TS-950)** [TS-950SDX w/K1EA Ver. 8 Program \(Revised\)](#) English language
- (TS-950)** [TS-950SDX Speech processor](#) English language
- (TS-950)** [TS-950SDX 3rd order IMD standardization](#) English language
- (TS-950)** [TS-950SDX Key click w/bug type keyer](#) English language
- (TS-950)** [TS-950 Hum with monitor ON](#) English language
- (TS-950)** [TS-950 Noise with Sub-Band noise blanker ON](#) English language
- (TS-950)** [TS-950 14.200 MHz transmit spur](#) English language
- (TS-950)** [TS-950 Low power output after temp. protection](#) English language
- (TS-950)** [TS-950 Infinite SWR at beginning of transmission](#) English language
- (TS-950)** [TS-950 Smoke from antenna tuner unit](#) English language
- (TS-950)** [TS-950S/SDX Transmit spur](#) English language
- (TS-950)** [TS-950SDX "click noise" with NOTCH ON](#) English language
- (TS-950)** [TS-950SDX YG-455S-1 Installation note](#) English language
- (TS-950)** [TS-950SDX No VFO B after "split"](#) English language
- (TS-950)** [TS-950SDX Carrier point adjustment](#) English language
- (TS-950)** [TS-950SDX Sub band residual noise](#) English language
- (TS-950)** [TS-950SD 18.115 MHz spur](#) English language
- (TS-950)** [TS-950SDX Change of Gate resistor type](#) English language
- (TS-950)** [Countermeassure against cold solder joint at the resistor block; CP1-CP4 in the PLL unit.](#) English language

- (TS-950) [Kenwood TS-950S & TS-950SD RF gain mod](#) English language
- (TS-950) [Implementation of the K6XX QSK Waveform Mod in the TS-950SD](#) English language
- (TS-950) [TS-950 SO2 Adjust](#) English language
- (TS-950) [Using Subreceiver to Improve TS-950 Noise Blanker](#) English language
- (TW-4000) [Umbau des Kenwood TW4000A für den Betrieb mit 9600 Baud Modem G3RUH](#) German language
- (TW-4000) [Kenwood TW-4000 for CAP](#) English language
- (TW-4100) [Modificatie KENWOOD TW-4100E voor subtone](#) Other language
- (TW-4100) [BandMod for TW4100](#) English language
- (TW-4100) [TW-4100 repeater stop scan on the UHF band](#) English language
- (VFO-120) [VFO-120 Dial Lamp Switching Circuit](#) English language

22-04-2000

(AT-50) AT-50 Blows ACCY fuse in TS-50S

Author: Kenwood Communication, inc.

Service Bulletin no. 1010 (30 April 1993)

Symptom:

Attempting to tune the AT-50 when it is connected to an antenna with a relatively high SWR value might cause the ACCY fuse to open in the TS-50S. This change will correct this tendency.

Parts required:

.047 μ F disc ceramic capacitors, CK45B1H473Z, QTY. 2

Procedure:

1. Remove the top cover from the antenna tuner.
2. Locate X53-3470-00 D/4 (It is attached to the top left side of the chassis with the foil side up).
3. Add the two .047 μ F capacitors as shown in the drawing below.
4. Replace the top cover.

No additional adjustment or modification will be required.

Caution: *This modification requires soldering equipment rated for CMOS type circuits. It also requires familiarity with surface mount soldering techniques. If you do not have the proper equipment or knowledge do not attempt this modification yourself. Seek qualified assistance.*

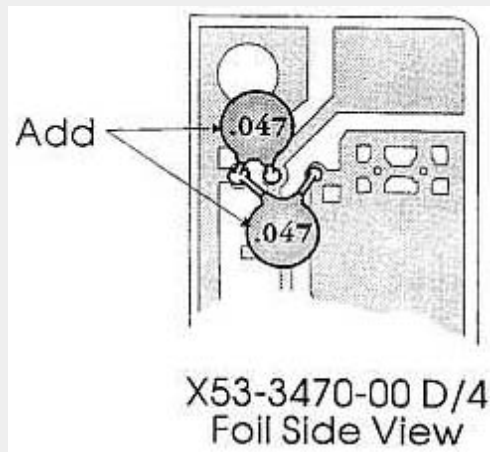

Time required for this modification is 30 minutes or less.

This modification is read 996 times.

[top of page](#)

23-04-2000

(AT-50) AT-50 Blows ACCY fuse in TS-50S (Part 2)

(Supercedes ASB-1010 dated 30 April, 1993)

Symptom:

Attempting to tune the AT-50 when it is connected to an antenna with a relatively high SWR value, especially on the 3.5 MHz band might cause the ACCY fuse to open in the TS-50S.

Parts required:

Qty	Description	Kenwood Part No.	Circuit description
2	Toroidal coil	L33-0699-05	NA

Procedure:

1. Remove the top and bottom covers from the antenna tuner.
2. Locate X53-3470-00 D/4 (it is attached to the top left side of the chassis with the foil side up).
3. Remove the two .047 μ F capacitors shown in figure 1 if they are present.
4. Cut the foil and add one of the toroidal inductors as shown in figure 2.
5. Turn the tuner over and locate capacitor C123 and C124, as shown in figure 3.
6. Move the capacitors (or add new capacitors) to the locations shown in figure 3.
7. Cut the foil path and add the remaining toroidal inductor as shown in figure 3.
8. Remove jumper W106 as shown in figure 3. (Note: remove the jumper from the component side of the board).
9. Add a jumper from the ATG foil to W104 as shown in figure 3.
10. Replace the top and bottom covers.

No additional adjustment or modification will be required.

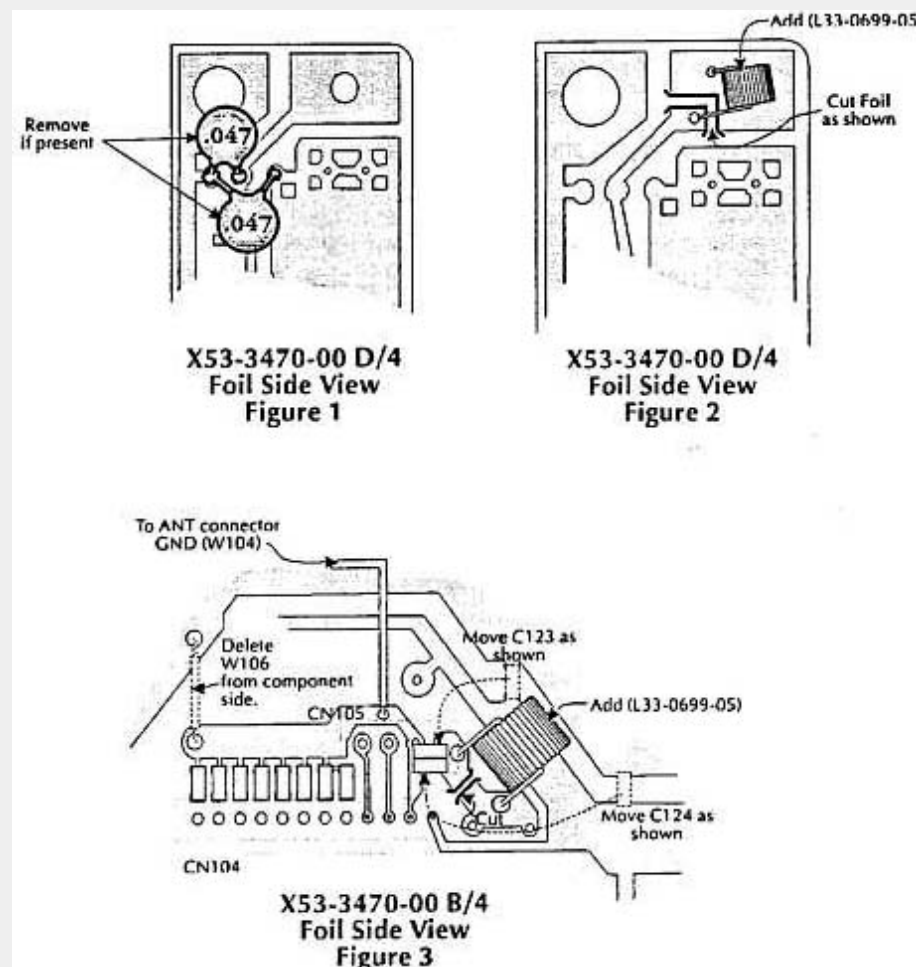

Caution: This modification requires soldering equipment rated for CMOS type circuits. It also requires familiarity with surface mount soldering techniques. If you do not have the proper equipment or knowledge do not attempt this modification yourself. Seek qualified assistance.

Time required for this modification is 30 minutes or less.

23-04-2000**(AT-50) AT-50 Mechanical stability****Author:** Kenwood Communication, inc.

Service Bulletin no. 1054 (28 March 1994)

Symptom:

When the unit is placed on a flat surface it appears to be slightly unstable, i.e. rocks back and forth when pressing down on the left front corner of the unit.

Procedure:

Add a flat spacer at the location shown between the chassis and the bottom cover.

Parts required:

Qty	Description	New Part No.	Circuit Description
1	Spacer	J30-0597-04	NA

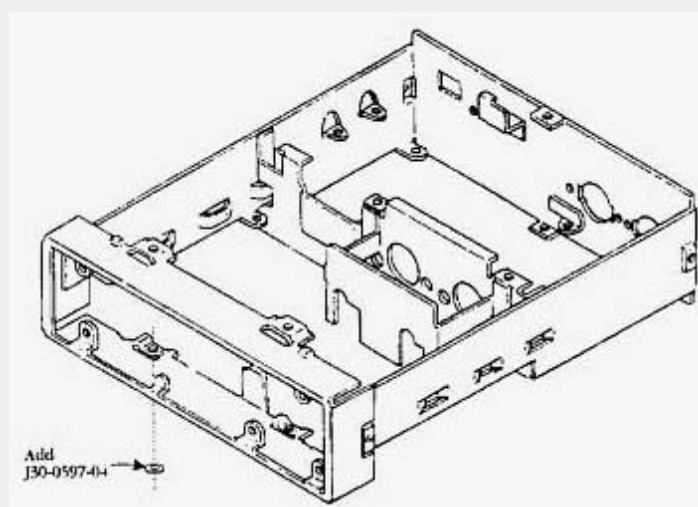

Time required for this modification is 15 minutes or less.

13-02-2000**(DG-1) Service Note on DG-1****Author:** Trio-Kenwood Communication, inc.

Service bulletin no. 26 (25-10-1977)

It is our experience here in the Compton service facility that the vast majority of DG-1 problems are not component failure, but cold solder connections on the digital PCB (X54-1160-00)

The second most frequent problem is dirty Molex connectors between the 2 PCB's in the DG-1.

Recommended service procedure: Remove both boards. Using a fine point, low wattage iron (less than 45W), and a good quality, low flux content solder, carefully resolder all components. (There are 18 of these points - only one is not top accessible, but is located under IC 11 and can be resoldered from the bottom).

Resolder the Molex connectors. There are 9 print-thru's where solder may not have flowed thru to the component side.

Using a good quality tuner cleaner with silicone lubricant, spray both boards Molex connectors and work the pins in 3 or 4 times to insure good contact. Reassemble and final check.

Total time on the bench: 20 minutes. We will allow up to 1 hour only warranty labor time.

20-02-2000

(DG-1) DG-1 Standard service procedure

Author: Trio-Kenwood Communication, inc.

Service Bulletin no. 53 (10-8-1979)

Introduction

A majority of DG-1 failures are caused by either dirty connectors, or cold soldered connector pins between the top and bottom foil paths of the double printed board.

Before any component level service is attempted, it is advisable to eliminate the possibility of an intermittent connection causing or complicating Counter failure.

1. **Physically disconnect the main power cord!**
2. Remove cabinet covers; top with speaker lead, and bottom.
3. Unplug the top and bottom connectors from the DG-1 unit.
4. remove the Digital Unit assembly by removing 4 screws from the chassis underside.
5. Disassemble the Digital Unit; remove 8 screw and slide off the cover.
6. Remove both PC Board, 4 screws each.
7. For those connector pins joining top and bottom foil paths; reheat pin, flow .031" diameter solder from the top to insure the solder joint through the PC Board.
8. Wash the board to board Molex connectors with FRESH trichlorethylene. Heat dry and inspect for flux residue. If necessary, reclean. Also remove the pin connectors from the DG-1 chassis, (note they insert from the Digital PC Board side) and clean in FRESH trichlor. Heat dry and spray with silicone lubricant.
Spray into the board mounted connectors with silicone.
9. Reassemble by reversing step 8,6 and 5.
10. Reinstall by reversing step 4, 3, and 2.

How to solder on the DG-1 board.

1. Use a low power pencil, 35 W or less!
2. Use rosin code solder, small diameter.
3. Do not create solder bridge or splotches.
4. Do not overheat or otherwise lift the foil from the board.
5. Wash excess flux away with FRESH trichlorethylene and a small flux brush. Neatness counts -- it's YOUR radio.

Note:

1. The best possible method of cleaning the Molex connectors is by ultrasonic cleaner and fresh solvent. Otherwise, use a spray.
2. In extreme cases, replace the Molex connectors, 6 pieces E40-0607-05.
3. For 15 & 10M invalid numbers, such a backward "6", replace D13, D14 SV-03 on the Counter Mix unit X54-1150-00. These are three section diodes (three junctions in one package) V21-0007-05.
4. For random or rolling display which will not correct by cleaning connectors, etc., check the CCR mixer input level. It should be 50mV measured with a high RF VTVM, and can be adjusted by TC-1 on the IF unit X48-1150-00, and measured on the IF TP6. (TS-820S Service Manual states 0.1mV- correct this to 50mV).

This modification is read 483 times.

[top of page](#)

13-02-2000

(DG-5) Repairing DG-5

Author: Trio-Kenwood Communication, inc.

The most common problem we have found with the DG-5 to date has been associated with the RCA type jacks. The majority of the DG-5's we have received here for repair have had dirty center pins on the jacks. The cause appears to be excessive rosin from soldering running into the center pin.

The standard repair has been to clean the center pin with solvent. Another possible problem is a cold solder connection at the RCA jack. You should also check the interconnecting cables for continuity. This should take care of about 90% of the DG-5 repairs you will see.

This modification is read 590 times.

[top of page](#)

19-02-2000

(DG-5) Repairing DG-5

Author: Trio-Kenwood Communication, inc.

Service bulletin no. 28 (3-2-1978)

1. Symptoms: Two dots on LED display
Check: Het input and VFO input connections (Dirty, intermittant, missing).
2. Display reading wrong frequency
Check: If display frequency is reading off by 2MHz and last four digits on display reading (894.9) check carrier input wire (dirty, intermittant, missing).
3. No display or dim display, digits missing.
Check: 5V reg (IC power) not working or plated thru holes not plated thru.

Above are common mechanical failures that occur with DG-5. We suggest the following troubleshooting procedure:

- A. Power all power supply levels.
- B. Reference oscillator (Q21) and divider chain IC5-IC11 (RF, waveforms, DC).
- C. Carrier, VFO and het, also counter (when applicable) for RF, waveforms and DC levels; See service manual for proper levels.

Note: Operation of the circuits are essential before proceeding.

It's been Kenwood's experience that when problems do occur with the DG-5 that approximately 90% of the problem will be caused by insufficient solder connections and not the actual components themselves.

Note: We suggest the following procedure if BUFFERS, MIXERS and OSCILLATORS are working properly: See service manual for proper levels.

Check

- A. All solder connections (loose or good).
- B. Solder all plated thru holes; 32 gauge wire inserted in plate holes takes approximately 30 minutes to do and 15 very, very effective.

Service suggestions:

A heat gun and freeze spray often are very effective in locating cold or non-plated thru holes.

- A. Heat board with heat gun (expands board).
This often caused dormant or loose connection to appear.

This modification is read 569 times.

[top of page](#)

19-02-2000

(DG-5) Theory of Operation

Author: Trio-Kenwood Communication, inc.

Service bulletin no. 29 (8-2-1978)

The DG-5 is a dynamic display type frequency counter. All this means is that fewer wires and decode drivers are needed for frequency displaying.

We shall start the explanation of the DG-5 with the reference osc. (Q21). This circuit provides the timing pulses, calibration and scanning pulses for operation of the DG-5. The ten MHz ref. osc. is divided 1/10 by IC5 to provide calibrated one MHz output. It is then further divided by IC6 and IC7 1/100. The divided signal is then passed thru IC8 which consists of two sections, a 1/5 and 1/2 divider. The divide by 1/5 section now gives a resultant 2KHz signal on its output. This is the scanning pulse. IC40 receives the scanning pulse which is a decode driver (Neg. Logic Type) is used to switch Q25-Q30 via terminals T1-T6 to put a plus voltage on display D1-D3 (LED Type).

At the same time, outputs T1-T6 of IC41 are inverted by IC42 positive logic and the B.C.D information is presented to IC32-IC37 the and-or-invert gates which provide the conditional inputs for the multiplexer or distributor. IC38 provides Neg. Logic inversion for IC39, the decode driver.

The multiplexer information starts with the heterodyne of three components, ref. osc., carrier and VFO input signals.

IC26-IC31 are the multiplexer inputs. These are latches which store B.C.D information until they are told to release their output by IC3 the strobe or latch signal.

I will mention now, that if the HET or VFO input signal are absent, that the blanking circuits will take effect. At this time the HET input is amplified and is wave-shaped by the Schmidt Trigger IC1 and IC1B. The carrier output is then mixed with the balance mixer Q16 and Q17. Its output is then mixed again with VFO and its output appears on Q18 drain. Its buffered by Q19 and wave-shaped by IC2B. This output is placed on timing window IC2C. Two signals are presented to the timing window; 1) signal to be measured, 2) gating signal .1 sec. in length (IC11 pin 8).

The DG-5 contains two window circuits IC2C and IC1C. IC1C forms the HET counter window circuit and IC2C forms the preset counter circuit.

With a gate signal the HET counter begins to count the pulses which pass thru the gate, and so does the preset counter circuit. The outputs of the timing windows are a ratio of signal input divided by gate pulse. Example, with a .1 sec. gating pulse the display would be updated once every .2 sec period. If a 1.2MHz input was measured, the display would read "1200" in KHz. The gated output information of IC1C is then distributed on the HET counters IC-12-IC18. At this time it should be realized that IC41 the decode driver is used merely to supply a pulse voltage to display and is controlled by 2 KHz scanning pulse. IC2D is gated with the same .1 sec. pulse and the output signal to be measured is the ratio of signal input (VFO. ref. and carrier) divided by gate pulse.

Both HET and preset B.C.D. information is presented to latch circuits which is then sent to decode driver IC39 for display information. Since only one decode driver is being used for all displays, the conditional inputs of IC32-IC37 must be turned "on" and "off" quickly in order not to be detectable by the human eye. This is done easily by the high speed TTL circuits.

Note: The display scheme of the DG-1 and DG-5 are essentially the same. The theory of operation is therefore applicable to the DG-1 display as well.

This modification is read 567 times.

[top of page](#)

20-02-2000

(DG-5) DG-5 Standard service procedure

Author: Trio-Kenwood Communication, inc.

Service Bulletin no. 54 (10-8-1979)

(Supplement to the DG-5 Service Manual)

Introduction

A majority DG-5 failures are caused by nothing more than an intermittent opening of a plated-through hole connecting top and bottom foil paths of the PC Board.

Before any component level service is attempted, it is advisable to eliminate the possibility of an intermittent connection causing or complicating Counter failure.

Procedure:

1. Disconnect all cables.
2. Remove cabinet; 2 screws at the rear, 2 screws with star washers on the bottom.
3. Disassemble display from chassis; 4 countersunk screws on the side rails.
4. The display unit has 2 through holes without leads, and the Counter main Board has 82 through holes without leads passing through them. Ideal service would be to first remove all solder from these holes using devices as a Pace Sodr-X Tractor, EREM Soldovac, or WIK-IT braid. Then pass a length of #24 tinned bare wire into each clean through hole, solder, and clip flush. For the 10 holes listed under IC's solder sparingly so as not to create a solder bridge under the component. For the remaining 72 holes, inspect each "pinned" connection from both sides to insure (1) no bridge and (2) a good solder joint.
5. Wash the Display to Counter Board PC Board connectors (male and female) with FRESH trichlorethylene. Heat dry and inspect for flux residue. Spray the connectors with silicone.
6. Similarly, clean and coat the rear panel RCA jacks as in step 5.
7. Reassemble, reversing step 3,2,1.

How to solder on the DG-5 PC Board

1. Use a low power pencil, 35W or less!
2. Use rosin core solder, small diameter.
3. Do not create solder bridge or splotches.
4. Do not overheat or otherwise lift the foil from the board.
5. Wash excess flux away with FRESH trichlor. and a small flux brush. Neatness counts - it's YOUR radio.

Through hole accounting

Display unit - 2
Counter unit - 82
Total 84

Locations:

a. Under; IC2, 4, 13, 20-25, 34 1 each
Total - 10

b. Adjacent or IC3, 13-14, 15-16, 22-23 - 1 each
between; IC1-2, 6, 18 - 2 each
 IC12 - 3 each

Total - 13.

c. Located between IC13-18, 20-25 - 5
rows; 20-25, 26-31 - 10
 IC26-31, 32-37 - 15
 IC32-37, 38-39 - 25

Total - 55

d. At rear FS7805 regulator - 1
panel; 2SD235 transistor - 3
Total - 4

e. Display unit - 2

Additional Point

1. R126 & R129 are power resistors located at the left rear corner of the PCB. remove the tubing from their outside legs and resolder each lead to the top foil path. Specific symptom for this failure is no display, & NO DECIMALS.
2. For counters which "roll", random count, or inject hash noise back into the TS-520/520S especially when hot, install an additional .1uF @ 12V bypass cap across the FS7805 regulator on the foil side of the PCB from the center ground lead to the outside leg, across C89.
3. For complaint of "hum" or Digital noise from the DG-5 back into the TS-520/s, both during RX & TX, tighten the mounting screws which supply ground to the Carrier unit X50-0009-01 in the transceiver.

This modification is read 566 times.

[top of page](#)

19-07-1998

(GENERAL) KENWOOD TH-series HT TNC Interconnection

The following is a suggested circuit for connecting a packet TNC to a Kenwood TH-series HT. Included is the TH-21/31/41, the TH-205/215/315/415, and the new TH-25/45 series HTs.

The connections are as follows:

A sub-miniature plug is used for receive audio. The tip of this plug is audio out; the sleeve of this plug is the common ground for PTT, transmit audio, and receive audio.

A miniature stereo plug is used for transmit audio and PTT. Connect the middle "ring" of the plug to the TNC audio out through a 0.2 uf cap (for DC isolation). Connect the sleeve of the plug to the TNC PTT. The plug's tip is unused.

Set the TNC audio for 50 to 80 mv audio output into a 2K ohm impedance.

This modification is read 950 times.

[top of page](#)

19-07-1998

(GENERAL) Service manual rx section level diagrams

Author: Trio-Kenwood Communication, inc.

Service Bulletin no. 941 (28-10-1988)

Introduction

This bulletin will explain the development and use of Kenwood Service Manual receiver section level diagrams. Since they list typical RF and audio levels, the diagrams provide the most efficient means of locating a faulty RX circuit in a transceiver.

In the past, Kenwood has recorded RF levels in volts (V), decibels (dB), and more recently dBu and dBm. Conversion tables and an equation are provided at the end of this text so you can change the RF levels to the form of your choice.

Using the level diagrams require basic test equipment and a couple of test fixtures. One fixture is an 8 ohm non inductive load that replaces the internal speaker. The other is an injection probe. It is used to inject RF from your signal generator into specific sections of the receiver. Both fixtures are discussed at the end of this text.

How the rx section level diagram is developed

This section will describe how the level diagrams are made for CW and SSB transceivers. It will then discuss the different methods used for FM transceivers.

A working transceiver is tuned to its center frequency. For HF rigs, this would be 14.200MHz. A Standard Signal Generator (SSG) set to the same frequency is connected to the antenna terminal of the transceiver. The SSG is set to a level that will not allow the AGC circuits to function (no S-METER reading). For HF rigs, this would typically be 0dB μ (0.5 μ V).

An 8 ohm load is inserted into the external speaker jack and the AF gain control is adjusted to obtain 0.68V across the load (measured with an AF VTVM). The AF gain setting is not changed from this point on. The SSG is replaced with a 50 ohm load to terminate the antenna input.

An injection probe is connected to the SSG. The ground clip is attached to the chassis of the transceiver. The probe is placed at the first point listed on the level diagram just past the antenna input. The SSG level is adjusted until the audio output is again 0.68V. The SSG level is then listed on the diagram as a typical reference for that point. This process is repeated until all measuring points are assigned a reference level.

NOTES

After each mixer stage, the SSG must be adjusted to the respective IF frequency. As an example, after the first mixer on the TS-940S, the frequency would be set to 45.05MHz. After the second mixer, the frequency would be set to 8.83MHz.

The levels in the audio stage of the receiver are measured with an AF VTVM. These measurements are made when the SSG is connected to antenna terminal (just after the AF gain is set).

FM rx section level diagrams

FM transceiver level diagrams are made in the same fashion as CW/SSB diagrams. The transceiver is tuned to its center frequency (or close to it). A low level signal is applied to the antenna terminal. The audio output is held constant while the injection method is used. The differences are as follows:

On some FM transceivers, the injected signal is modulated (typically a 1KHz tone at +/- 3.0KHz deviation is used). Other transceivers are tested without modulation.

On some transceivers, the constant output is measured at 12dB SINAD. On others it is measured at 20dB of noise quieting (NQ).

Each Service Manual level diagram contains footnotes that describe the method used. Due to the variations and available test equipment, it may be necessary to change the initial set up and then write your own level diagram.

Using the level diagram to troubleshoot a faulty receiver

It is not practical to set the audio output to a specified level by injecting a signal into the antenna terminal of a transceiver that has low sensitivity. In many cases, the input signal would be so strong that it would attack the AGC circuits. This would cause all measurements in the receiver to vary from the typical levels in the diagram. The best approach to this situation is to start at the end of the receiver circuit and work towards the antenna.

Connect a 50 ohm load to the antenna terminal and an 8 ohm load to the external speaker jack. Inject a signal at the end of the IF stage. The IF frequency and required level are listed on the Service Manual level diagram. Adjust the AF gain control to obtain the specified audio level at the 8 ohm load. Do not change the AF gain setting from this point on. Inject the next signal in the middle of the receiver chain (again refer to the level diagram for the frequency and level). If the audio comes up to the specified level, the faulty component is somewhere between the antenna terminal and the middle of the receiver. If the audio does not come up, the bad

component is between the two injection points.

Decibels

As mentioned in the instruction, Kenwood Service Manuals have listed levels in V, dB, dB μ , and dBm. Unless otherwise specified in the footnotes on the level diagram, dB and dB μ levels are equal.

Aside from the conversion tables on page 6, a conversion equation and examples are provided.

$$\text{Equation: } \text{dB} = 20 \log \frac{V(\text{out})}{V(\text{in})}$$

In the equation, solving for dB would yield a value that is the difference between the two voltages. In other words, suppose you already know that $2\mu\text{V} = 12 \text{ dB}\mu$ and $15.8 \mu\text{V} = 30 \text{ dB}\mu$. You can see that the difference is $18 \text{ dB}\mu$. Plugging these μV values into the equation would yield the same result. With this in mind, one can plug in a known voltage from a conversion table, plug in a voltage not listed in the table, and find the dB difference. To make the answer simplistic, use $0.5 \mu\text{V}$ for dB/dB μ and 224 mV for dBm. Since they equal $0 \text{ dB}/0 \text{ dB}\mu/0 \text{ dBm}$ respectively, the difference is the actual value of the unknown voltage.

Example: Given $0.5 \mu\text{V} = 0 \text{ dB}\mu$,
Find the dB μ value of $6 \mu\text{V}$.

$$X_{\text{dB}\mu} = 20 \log \frac{6 \times 10^{-6}}{.5 \times 10^{-6}}$$

$$X_{\text{dB}\mu} = 20 \log 12$$

$$X_{\text{dB}\mu} = 20 (1.08)$$

$$X_{\text{dB}\mu} = 21.6$$

$$X = 21.6 \text{ dB}\mu$$

Example: Given $224 \text{ mV} = 0 \text{ dBm}$,
find the dBm value of $6 \mu\text{V}$.

$$X_{\text{dBm}} = 20 \log \frac{6 \times 10^{-6}}{224 \times 10^{-3}}$$

$$X_{\text{dBm}} = 20 \log 26.8 \times 10^{-6}$$

$$X_{\text{dBm}} = 20 (-4.6)$$

$$X_{\text{dBm}} = -91.4$$

$$X = -91.4 \text{ dBm}$$

$$\text{Reminder: } 6 \mu\text{V} = 6 \times 10^{-6} = 0.000006$$

$$224 \text{ mV} = 224 \times 10^{-3} = .0224$$

The next injection point would again cut the chain in half in order to work towards the faulty component. For instance, if the problem is between the antenna terminal and the middle of the receiver, inject the next signal in the middle of those two points. Continue in this manner until the problem can be isolated to a small portion of the circuit.

NOTE

Do not forget that D.C. measurements around an isolated circuit are necessary. For instance, an amplifier will not have any gain if an open resistor cuts off the supply voltage.

Injection probe

An injection probe is a coax that connects to your SSG, has a $0.01\mu\text{F}$ capacitor on the center conductor of the coax, and a tip connected to the other end of the capacitor. The shield of the coax connects to a ground clip. Many electronic supply shops sell injection probes. If you decide to purchase one, make sure it contains a $0.01\mu\text{F}$ capacitor between the tip and center conductor of the coax (used to block D.C.). If you decide to fabricate your own cable, it can be done with a few simple parts as shown in Figure 1.

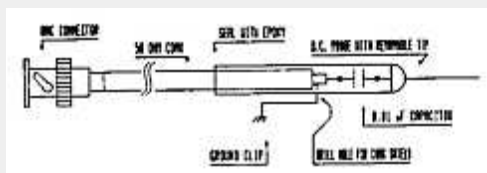

8 OHM load

An 8 ohm non inductive load is used to substitute the internal speaker on the transceiver. The load is connected to the external speaker jack for convenience. For the purpose of troubleshooting a faulty receiver, it is not necessary to purchase a precision 8 ohm resistor (also, precision resistors are inductive). Six carbon composite 47 ohm, $1/2$ watt resistors connected in parallel make an adequate load. Figure 2 shows a typical 8 ohm load fabrication.

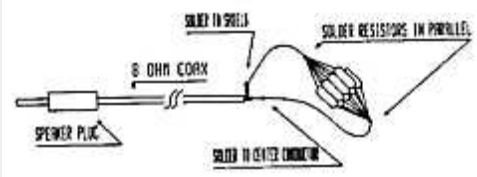

Suppose you are given a dB value from the level diagram and you want to know its equivalent voltage:

Example: Given $0.5 \mu\text{V} = 0 \text{ dB}\mu$,
Find the dB μ value of 55dB μ .

$$55 = 20 \log \frac{X}{.5 \times 10^{-6}}$$

$$2.75 = 20 \log \frac{X}{.5 \times 10^{-6}}$$

$$\text{antilog } 2.75 = 20 \log \frac{X}{.5 \times 10^{-6}}$$

$$562.3 (.5 \times 10^{-6}) = X$$

$$281 \times 10^{-6} = X$$

$$281 \mu\text{V} = X$$

Example: Given $224 \text{ mV} = 0 \text{ dBm}$,
find the dBm value of -55 dBm .

$$-55 = 20 \log \frac{X}{224 \times 10^{-3}}$$

$$-2.75 = 20 \log \frac{X}{224 \times 10^{-3}}$$

$$\text{antilog } -2.75 = 20 \log \frac{X}{224 \times 10^{-3}}$$

$$398.7 \times 10^{-6} = X$$

$$398.7 \times 10^{-6} = X$$

$$398.7 \mu\text{V} = X$$

Japanese "SSG"

American "SSG"

-6dB	-----	0.25 μV
0dB	-----	0.5 μV
6dB	-----	1 μV
12dB	-----	2 μV
24dB	-----	8 μV
30dB	-----	15.8 μV
40dB	-----	50 μV
50dB	-----	158 μV
60dB	-----	500 μV
70dB	-----	1.58mV
80dB	-----	5mV
90dB	-----	15.8mV
100dB	-----	50mV
120dB	-----	0.5V

TABLE 1 (dB or dBu to V conversion)

Japanese "SSG"

American "SSG"

-119dBm	-----	0.25 μV
-113dBm	-----	0.5 μV
-107dBm	-----	1 μV
-101dBm	-----	2 μV
-88.9dBm	-----	8 μV
-83dBm	-----	15.8 μV
-73dBm	-----	50 μV
-63dBm	-----	158 μV
-53dBm	-----	500 μV
-43dBm	-----	1.58mV
-33dBm	-----	5mV
-23dBm	-----	15.8mV
-13dBm	-----	50mV
0dBm	-----	224mV
7dBm	-----	.5V

TABLE 2 (dBm to V conversion)

19-07-1998

(GENERAL) How to build COMPUTER INTERFACE

- Kenwood models:

TS-140 TS-440 TS-450 TS-680 TS-690 TS-711
 TS-721 TS-811 TS-850 TS-940 TS-950

KENWOOD RS-232 INTERFACE

(P.C.)

DB-25S (DB-9S)

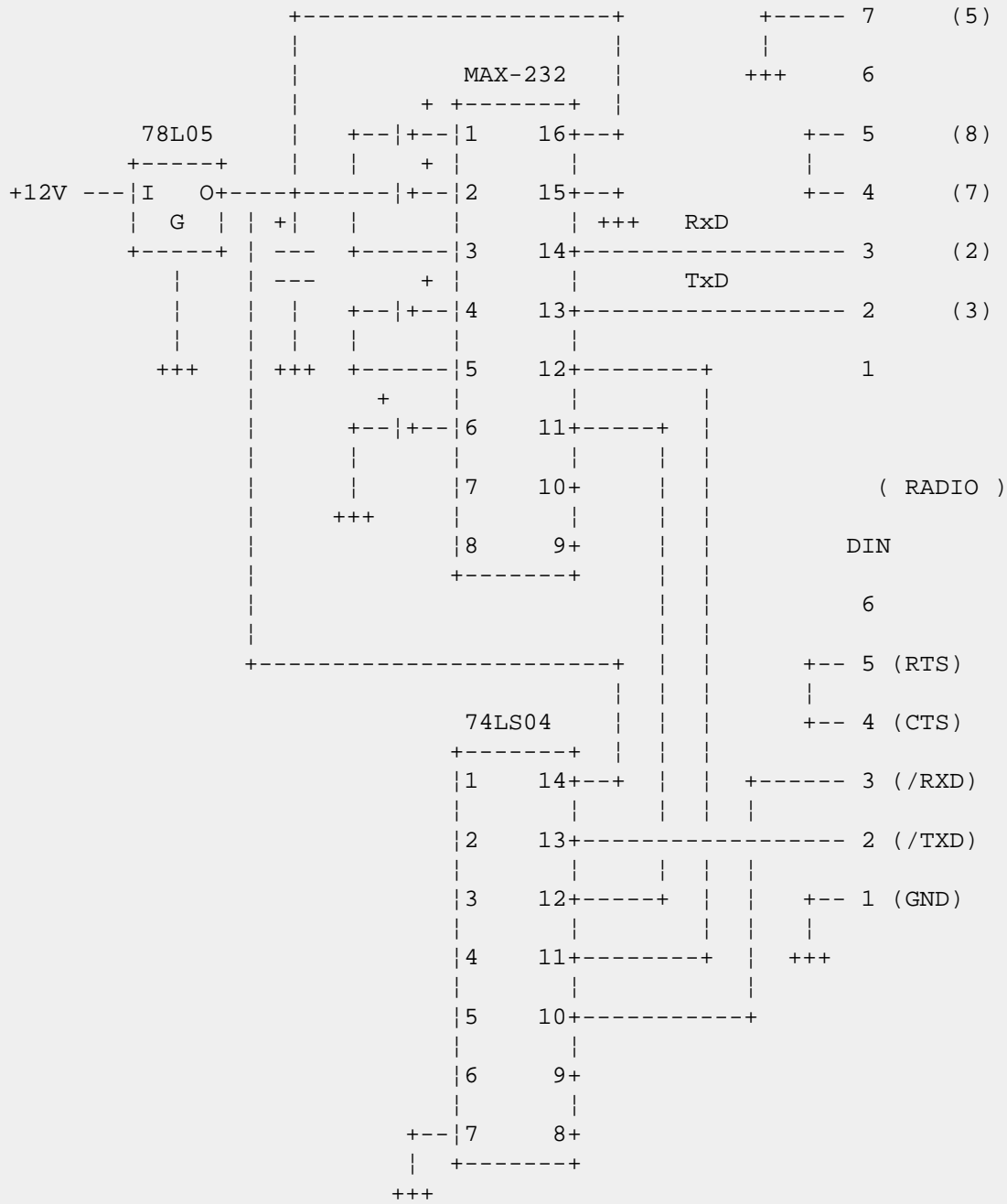

NOTES:

1. All capacitors are 22uF 16v
2. Radio connector is a 6 PIN DIN

19-07-1998

(GENERAL) How to remove Display-Scratches

hello, kenwood-fans!

Since a few minutes i'm happy about the new outlook of my ts440's display: it's free of scratches now!

During the last two years i used it as a mobile rig and had a lot of fun with it. now it is replaced by a ts50 (works very well!). During that mobile application the plastic cover of the display was damaged by little scratches- not too deep at all, but unpleasant to look on. may be, i touched it with the mike or car key.

So, back in the shack, i looked for a method to get it clear.

How?

With tooth paste!

No joke, it really works!

That's the way:

1. Clean the display with a wet(!) clean cloth
2. Cover areas not to be treated with insulating tape or s.e.
3. Take one wet edge of a cloth (i used that one from the kitchen reserved for to dry the finest dishes) and put it over your forefinger
4. Take a piece of tooth paste (the old fashioned white one, that contents polishing elements, i used "thera med", made by henkel") on that finger
5. Polish the display's surface by wiping in rotations -not strictly in one direction only- about 2 or 3 minutes
6. Clean the area with a fresh, but wet(!) cloth
7. Dry it with the other -dry- part of the clean cloth
8. Remove tapes
9. Injoy perfect brand new looking display!

Honestly said, it's not originally my idea. I was inspired by a friend of mine, who gave me this advice for a similar application (glass cover of my watch).

I'm not sure, if it works with icom or yaesu devices, so don't tell them (hi).

This modification is read 1046 times.

[top of page](#)

19-07-1998

(GENERAL) Kenwood 4 pin microphone connections to TNC

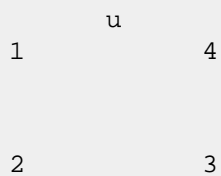

Pin 1 = MIC input

Pin 2 = PTT (Push To Talk)

Pin 3 = Ground

Pin 4 = Ground

NOTE

Please make sure that you are familiar with the pin numbers on the mic sockets (fitted to end of mic leads) before you make any connections.

This modification is read 831 times.

[top of page](#)

19-07-1998

(GENERAL) Kenwood 6 pin microphone connections to TNC



Pin 1 = MIC input

Pin 2 = PTT (Push To Talk)

Pin 3 =

Pin 4 =

Pin 5 =

Pin 6 = Ground

NOTE

Please make sure that you are familiar with the pin numbers on the mic sockets (fitted to end of mic leads) before you make any connections.

This modification is read 829 times.

[top of page](#)

19-07-1998

(GENERAL) Kenwood 8 pin microphone connections to TNC



Pin 1 = MIC input

Pin 2 = PTT (Push To Talk)

Pin 3 =

Pin 4 =

Pin 5 =

Pin 6 =

Pin 7 = Ground

Pin 8 = Ground

NOTE

Please make sure that you are familiar with the pin numbers on the mic sockets (fitted to end of mic leads) before you make any connections.

This modification is read 933 times.

[top of page](#)

(GENERAL) Kenwood mic modification

The following concerns modificatio of some Kenwood Microphone.

Note: What follows is just suggested, proceed at your own risk.

If you have a Kenwood TM-xxxE (European version) trans', Than your mic, probably has 1750 Hz baton, Which is useless in some countries (not if you are a jammer Hi). This baton can Probably be transformed to have another transceiver function.

I myself, tested the above & succeeded with both: TM-241E & TM-741E (of which the mic's slightly differ).

GENERALLY (at least in the two above) the 1750 Hz baton provides aprox' 7.5v (when depressed), in order to generate the tone. While the other 3 control baton on the mic provide lower voltage levels (aprox' 1.5v & 3.5v if i remember correctly). The idea is simply to disconnect the 7.5v at the baton input & to connect the other voltage level (1.5v or 3.5, I forgot which). To do this follow the next modif' stages.

MODIFICATION STAGES:

- 1. Disconnect the 7.5 voltage level by cutting the only jumper on the print. (to be sure measure 7.5v relative to ground on it, on the 741E mic it is symbolized by J1)

```
the TM-741E
ZDDDDDDDDDDDDDDDDDDDDDDDDDDDD?
3 ZDDDDDD? 3
3 3 ptt 3 3
3 3switch3 3
3 @DDDDDDY 3
3 DD 3
3 J1 3
3 3
3 3
@DDDDDDDDDDDDDDDDDDDDDDDDDDDDY

the TM-241E
ZDDDDDDDDDDDDDDDDDDDDDDDDDDDD?
3 ZDDDDDD? 3
3 3 ptt 3 3
3 3switch3 3
3 @DDDDDDY 3
3 DD 3
3 J3 3
3 3
3 3
@DDDDDDDDDDDDDDDDDDDDDDDDDDDDY
```

- 2. Short the 2 connections on:

```
the TM-741E
ZDDDDDDDDDDDDDDDDDDDDDDDDDDDD?
3 ZDDDD? 3
3 3 3 3
3 3
3 3 3 3 3 3 3 3 3
3 0 0 0 0 3
3 3 3 3 3 3
3 3 3 3 3 3
3 3
3 1750 VFO MR PF 3
3 3
3 3
3Microphone T91-0398-XX3
@DDDDDDDDDDDDDDDDDDDDDDDDDDDDY

the TM-241E
ZDDDDDDDDDDDDDDDDDDDDDDDDDDDD?
3 ZDD? 3
3 3 3 3
3 3
3 3 3 3 3 3 3 3 3
3 0 0 0 0 3
3 3 3 3 3 3
3 3 3 3 3 3
3 3
3 1750 VFO MR PF 3
3 3
3 3
3Microphone T91-0398-X53
@DDDDDDDDDDDDDDDDDDDDDDDDDDDDY
```

The new function becoms:

```
^
3
3
default:call
programable:PF4

^
3
3
call
----
```

DE Ze'ev 4X4CV @4X1RU.ISR.MDLE

This modification is read 1164 times.

[top of page](#)

(GENERAL) Optional narrow ceramic filters

The optional filters listed below are for a narrower bandpass. Some will have different input & output impedance, & some will require new mounting holes. Only one will require a component change.

Model	Standard	Option	Installation
TR-2200DA	CFM-455E	CFR-455G	Just replace
TR-7200A	CFR-455F	CFR-455G CFS-455G	Just replace Modify PCB mounting
TS-700A/S/SP	CFR-455F	CFR-455G CFS-455G	Just replace Just replace
TR-7400A	CFR-455F	CFR-455G	Just replace
TR-7600/7625	CFR-455F2	CFL-455F CFR-455G	Replace C101 470pF to .00uF Replace C101 with .001uF & modify PCB mounting.
TR-8300	CFM-455R	CFM-455F	Just replace

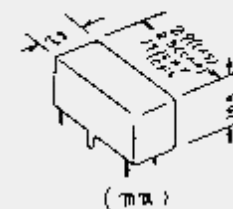

Specification

Filter Model	Part Number	-3 dB Down Bandwidth	-6 dB Down Bandwidth	Bandwidth	Impedance In/Out
CFM-455E	L72-0025-05	More than ± 5.5KHz	More than ± 8KHz	60dB ± 16KHz	1500 ohm
CFR-455F	L72-0037-05	± 4.5KHz	± 6KHz	70dB ± 16KHz	2000 ohm
CFR-455G	L72-0302-05	----	± 4KHz	70dB ± 16KHz	2000 ohm
CFS-455G	L72-0303-05	----	± 4KHz	80dB ± 16KHz	2000 ohm
CFT-455F2	L72-0309-05	± 5KHz	± 7.5KHz	60dB ± 16KHz	1500 ohm
CFL-455F	L72-0306-05	± 4.2KHz	± 6KHz	70dB ± 16KHz	2000 ohm
CFM-455F	L72-0000-00	± 4.2KHz	± 6KHz	± 12 KHz	2000 ohm

This modification is read 882 times.

[top of page](#)

02-04-2000

(GENERAL) VFO-230 Operation on 240V AC

Author: Trio-Kenwood Communication, inc.

Service Bulletin no. 838 (15-12-1980)

To operate the VFO-230 on 240V AC, the power transformer primary tap must be rewired from 120V to either the 220V or 240V tap.

1. Unplug the AC power cable and VFO interconnecting cable.
2. Remove the top cover.
3. Move the AC line from the 120V (Red) to either the 220V (Green) or 240V (Blue) transformer winding.
4. Change the AC fuse from 0.5A to 0.3A. Tag the power cord at the back of the unit to indicate that the transformer is wired for 240V AC, and the power fuse should be 0.3A and not 0.5A.
5. Replace the top cover and cable up to verify your work.

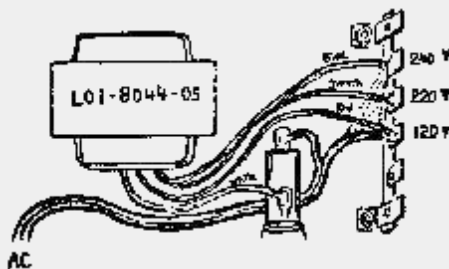

This modification is read 790 times.

[top of page](#)

16-04-2000

(GENERAL) Service manual TX level diagrams

Author: Trio-Kenwood Communication, inc.

Service Bulletin no. 942 (30-10-1988)

Introduction

Kenwood service manual transmit level diagrams provide typical RF levels found in working transceivers. This information provides a fast method of locating a faulty circuit in a transmitter chain. To use the level diagrams, an AF VTVM, RF VTVM, and 50 ohm resistive load are required. In addition, since many units are tested with the drive output terminated into the load, a coax cable must be fabricated. A sample cable is shown below.

How the TX level diagram is developed

The transmit level diagrams are developed in a similar manner as the receive diagrams. Basically, a working transceiver is tuned for a specified output power at center frequency. The mic audio circuit is measured with an AF VTVM and the RF circuit is measured with an RF VTVM. The results are listed on the diagram as typical levels for a working transceiver. The exact setup used to make a diagram varies with the model. The setup details are listed in footnotes on the diagram. No matter what procedure is used, the end result is a list of typical levels for a working transceiver.

For the most part, variations in setup include what mode is used, if audio is applied to the mic input, and what reference is used for power output. Additionally, many units have the drive signal connected directly to a 50 ohm load. This requires a fabricated coax cable that can be inserted into the drive socket and attached to a load. A coax cable with a terminal that fits the drive socket is available in the Kenwood Parts Department. SB-905 lists the part numbers of coax cables that are available in several lengths and style. Once a cable is obtained, a connector that matches your 50 ohm load can be soldered to the cable.

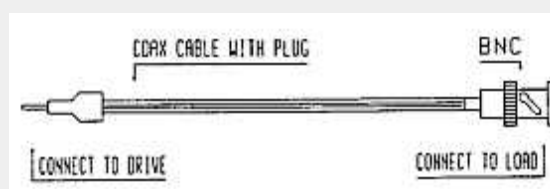

Using the TX level diagrams

As mentioned above, certain units are terminated at the drive output. This procedure can be used in troubleshooting to determine if normal drive power is available. Simply connect the fabricated coax cable to the drive terminal and the 50 ohm load. If the load receives full drive power as indicated on the level diagram, the trouble spot is in the Final or LPF unit. In this case, reconnect the Final unit and continue checking towards the antenna terminal. If low drive is measured, continue measuring toward the mic input until a faulty circuit is found.

Note

Once a faulty circuit is isolated, DC measurements must be made to determine if normal supply voltage is present.

This modification is read 1002 times.

[top of page](#)

23-04-2000

(GENERAL) Power module heat sink compound

Author: Kenwood Communication, inc.

Service Bulletin no. 1055 (28 March 1994)

Symptom:

Several current and past model transceivers do not use Heat Sink Compound on the power modules. Our engineering department determined through testing, that those models with fine casting or machined areas under the power module do not really require its use. Several service facilities and customers have questioned this and are concerned that this could eventually cause failure of the power modules(s).

Corrective Action:

In order to ameliorate any anxiety to increase you confidence out engineers recommend that you use Silicone Heat Compound whenever replacing any of these devices or whenever they must be lifted for service of other components on the board. Our production lines begin using this compound again as added protection for these devices.

Parts required:

Qty	Description	New Part No.	Circuit Description
1	Silicone Heat Sink Compound	W01-0411-05	NA

This modification is read 821 times.

[top of page](#)

16-05-2001

(GENERAL) The MIC pin configurations

Author: Robert - jg999@webtv.net. MODIFICATION.NET

To those who may desire to use a microphone with different transceiver (other than the microphone brand)

For Kenwood Mic to work with a Icom Radio wire the mic plug as described below The wire on

```
Pin #1 stays on Pin #1
#2 move to Pin #5
#3 stays on Pin #3
#4 stays on Pin #4
#5 move to Pin #2
#6 move to Pin #8
#7 stays on Pin #7
#8 move to Pin #6
```

For Icom Mic to Kenwood Radio you must perform a special Mod on the mic (also on this web site).

For Kenwood Mic to work with a Yaesu Radio wire the mic plug as described below. The wire on

```
Pin #1 move to Pin #8
#2 move to Pin #6
#3 stays on Pin #3
#4 move to Pin #1
#5 un-solder and tape
#6 un-solder and tape
#7 stays on Pin #7
#8 move to Pin #2 & #5
```

For Yaesu Mic to work with a Kenwood Radio just reverse the procedure described above.

Thanks
Robert

This modification is read 1145 times.

[top of page](#)

20-04-2000

(MC-44) MC-44DM Microphone audio improvements

Author: Trio-Kenwood Communication, inc.

Service Bulletin no. 958 (12-1-1990)

There are several ways to increase the transmit audio level when using an MC-44DM. If you are using a single band transceiver such as the TM-231A, you can turn up the deviation control inside the transceiver. Do not turn up the deviation controls in dual banders such the TM-731A because the audio will distort during repeater cross band operations.

Inside the microphone, there is a felt pad lightly glued to the microphone element housing. Removing the pad will increase the audio level.

If more level is desired, the microphone element can be changed to a more sensitive element. The element can be ordered through Kenwood's Parts Department.

ECM (microphone element) Part# T91-0393-08

This modification is read 615 times.

[top of page](#)

23-04-2000

(MC-44) MC44/MC44DM Intermittent modulation

Author: Kenwood Communication, inc.

Service Bulletin no. 1022 (18 May 1993)

Symptom:

Microphone audio is mechanically intermittent, i.e. striking the microphone will cause audio to be lost or restored.

Cause:

The lead wire of capacitor C8 might be shorting out against the case of the ECM unit.

Correct action:

Re-install the capacitor so that the leads cannot touch the ECM case.

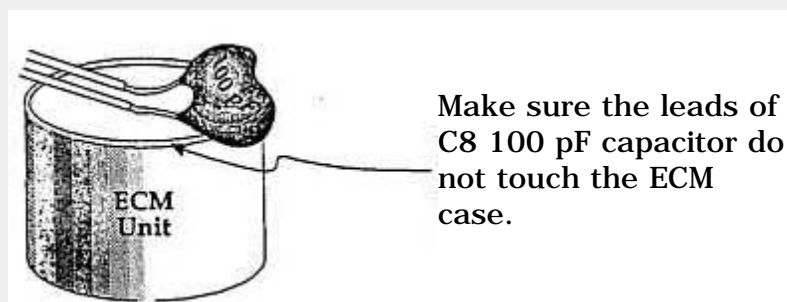

Time required for this modification is 15 minutes or less.

This modification is read 553 times.

[top of page](#)

19-07-1998

(MC-45) Making the MC-45 Microphone work on the TR-7400A

Author: Trio-Kenwood Communication, inc.

Service bulletin no. 35 (22-5-1979)

The MC-45 Touch Tone Microphone is supplied with a 5 pin connector installed on it. This allows it to be used with the TR-7600 and tr-7625 2M FM transceivers. The MC-45 may also be used with the TR-7400 if the microphone plug is changed to the 4 pin type used on the "TR-7400" (E07-0403-05) and the microphone socket on the TR-7400A is modified to supply power to the microphone.

The 5 pin microphone connector is changed so the PTT ground and microphone ground wires are connected together on the 4 pin plug. This means the wires on pins 4 and 5 of the 5 pin plug will be connected to pin 3 of the 4 pin plug. The other PTT lead (on pin 2) would go to pin 2. The microphone hot lead goes from pin 1 to pin 1. The power lead (on pin. 3) would be connected to pin 4 of the 4 pin plug.

The TR-7400A modification requires removing the front panel and Display Unit (X54-1210-10) so you may get to the microphone

socket. The switch board may not be removed.

The front panel is removed by taking off all the knobs first. The "MHz" switch knob is push-on type. All the other knobs are held on by set screws. (Be sure to note the position they are in so they will be reinstalled correctly.) The front panel is then removed by taking out the 4 screws (2 on each side) that hld the front panel on. You should remove the volume/squelch control at this time by loosening the nut and sliding the control up from the sub-panel.

Unplug all 6 display digit boards from the Display Unit (X54-1210-10). Be sure to keep the digit boards in order, as there are 4 different types used. The display unit is secured by 4 screws. Three of these screws are visible now. The screw that is nearest the S-meter also holds a bracket for 2 LED's. Remove this screw and carefully lift out the bracket. This will reveal the fourth screw. Remove the three screws that are left holding the Display Unit in place. This display unit may now be lifted out by the back of the circuit board to give you enough room to work on the microphone connector.

There is a jumper wire between pins 3 and 4 on the microphone socket. Remove this jumper. Pin 4 is the lower of these two pins. Install a wire from pin 4 to terminal C9 on the TX unit (X56-1210-10).

Reinstall the indicator unit (X54-1210-10) and replace the digit boards. Put the volume/squelch potentiometer back in place, next mount the front panel and knobs. This completes the modification.

The modified MC-45 microphone may now be connected to the TR-7400A. Depressing any key on the keypad will activate the PTT circuit and the tone circuit. There is also a short delay of 1/2 second that the PTT circuit will remain closed after the key has been released. This will allow you to key up several numbers without dropping the carrier.

This modification is read 366 times.

[top of page](#)

19-07-1998

(MC-46) MC-46 DTMF Mic. With older equipment

The MC-46 DTMF (Dual Tone Multi Frequency, or Touchtone (TM)) microphone may be adapted for operation with any VHF or UHF radio by changing the supplied six pin mic connector to a five pin, four pin, or other connector, as required. Radios not originally supplied with regulated, filtered B+ at the mic connector need also to be modified to power the microphone.

The MC-46 standard six pin mic connector is part no E07-0651-05, and is wired:

Pin 1 White	Mic Output
2 Red	PTT
3 Blue	Down
4 Green	Up
5 Brown	B+ (8.5 VDC +/- 10%)
6 Shield	

The Four pin connector part no is E07-0403-05. Radios built with a four pin jack do not supply B+ to operate the mic, and must be modified to deliver a constant source of DC to operate the mic and DTMF keyboard. Any Kenwood product of this vintage will have a B+ line designated "C9" (Common 9V DC), wich is regulated, filtered, and noise-free. Rewire the mic as described below:

Pin 1 White	Mic Output
2 Red	PTT
3 Shield	Common Ground
4 Brown	C9

Rewire the radio mic jack: pin 3 to common ground, pin 4 to C9.

Rewire the stock mic for pin 3 common ground. Otherwise, the mic element will be returned to C9, instead of ground. Note this change on the radio schematic.

The Five pin connector part no. is E07--551-05. Radios built with a 5 pin jack supply correct B+ for a DTMF mic (originally designated MC-45, and no longer available). Wire the mic as described below:

Pin 1 White	Mic Output
2 Red	PTT
3 Brown	B+
4,5 Shield	Common Ground

Mating chassis connectors are:

Four Pin	E06-0403-05
Five Pin	E06-0552-05
Six Pin	E06-651-05

This modification is read 309 times.

[top of page](#)

21-04-2000

(MC-48) MC-48B Mic element change

Author: Kenwood Communication, inc.

Service Bulletin no. 983 (6-2-1991)

The original microphone element has been replaced. The new element has two connections and is much smaller than the original three connection element. When installing the new element, connect the wires as shown below. A 33 Kohm, ¼ watt resistor must be placed in series with the yellow wire. The rubber spacer is placed in front of the element when the microphone is assembled. The metal spacer can be discarded.

Mic element part # T97-1024-08

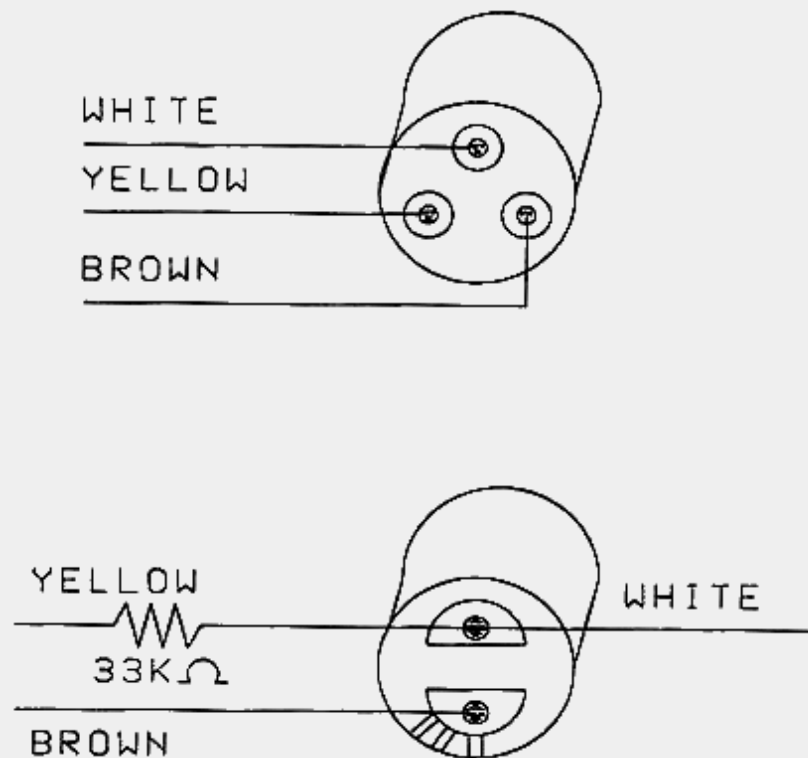

This modification is read 329 times.

[top of page](#)

13-02-2000

(MC-50) VOX-3 Sensitivity and Delay

Author: Trio-Kenwood Communication, inc.

Service bulletin no. 15 (26-5-1977)

There have been a few instances of improper VOX operation when the MC-50 microphone is used. The sensitivity of the VOX-3 may be increased by removing R-4 and connecting R-3 directly to ground.

Also install a 220mfd 25Vdc electrolytic in parallel with C-6.

(These parts are all on the X54-1010-00 board.) If the VOX delay is insufficient, change C-10 (on the X54-0001-00 board) from 3.3mfd 50Vdc to a 10mfd 50Vdc capacitor. Shown below is a modified schematic showing these changes.

SCHEMATIC DIAGRAM

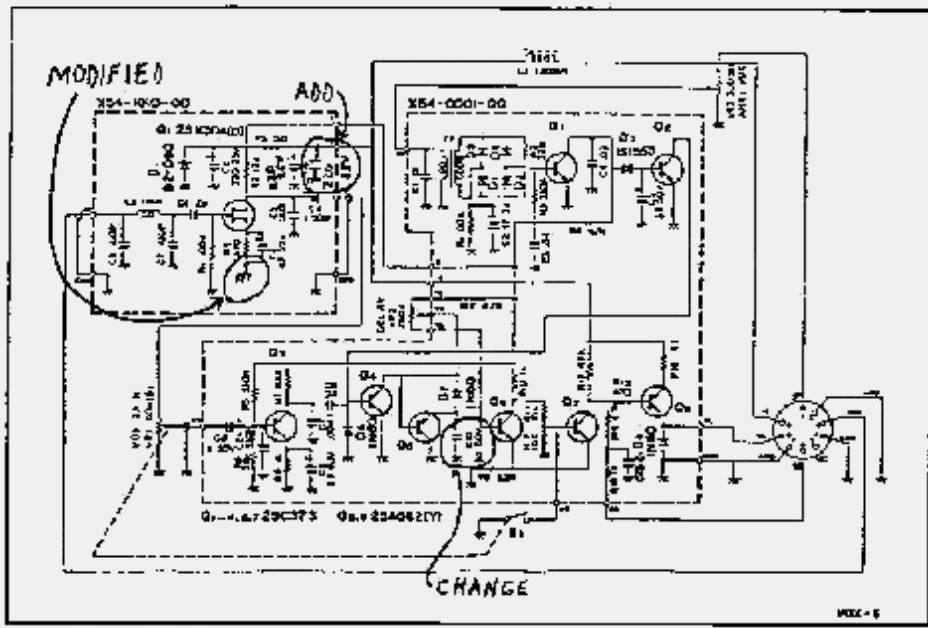

This modification is read 879 times.

[top of page](#)

20-04-2000

(MC-55) MC-55 Change in mic element (T91-0328-08)

Author: Trio-Kenwood Communication, inc.

Service Bulletin no. 953 (4-5-1989)

The new Mic element for an MC-55 comes in two pieces. One piece is a two pin ECM and the other piece is a spacer. The spacer is required as the new ECM is half the side of the old one. The wiring configuration is somewhat changed for the installation of the new Mic element. The figures below show the original configuration, the new configuration, and the assembly. The black wire is not used with the new ECM and a 330 ohm resistor is installed on the foil side of the microphone amplifier board. The leads of the resistor should be insulated with electricians tape or shrink tubing.

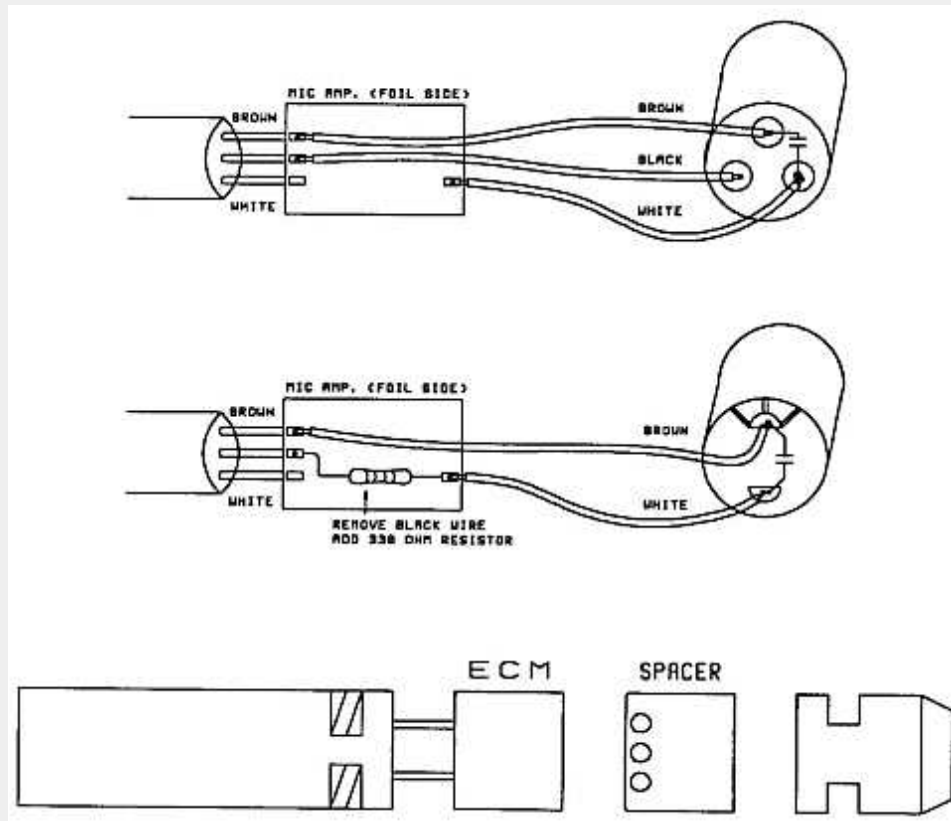

This modification is read 332 times.

[top of page](#)

11-07-2000

(MC-60) Modifikation MC-60

Author: Wolfgang Kind - dl5dkw@t-online.de.MODIFICATION.NET

Sehr geehrte YL's und OM's,

nachdem an mich mehrfach der Wunsch herangetragen wurde, eine Modifikation für das MC-60 zu publizieren, da dieses Mikrofon nachweislich nicht einstrahlungsfest ist, möchte ich dies hiermit nachholen.

Ich habe seinerzeit mein MC-60 in Verbindung mit einem TS-870 benutzt und war aufgrund von HF-Einstrahlungen ins Mikrofon auf allen 9 Amateurfunkbändern völlig unverständlich.

Daraufhin habe ich mir 3 Drosselspulen der Firma Neosid (100 oder 220µH) von der Firma Conrad Electronic (Stück 0,80DM) besorgt und wie folgt eingelötet:

Zuerst habe ich das Kabel zum Umschalter auf der Bodenplatte abgezogen und anschließend die kleine Verstärkerplatine ausgebaut und so positioniert, daß die Taster auf der Rückseite dieser Platine zum Körper zeigen.

Anschließend habe ich zuerst den Schalter auf der Bodenplatte durch 2 Drosselspulen nachgebildet. Hierzu werden die Löt-punkte der Buchse des Kabels, die zur Bodenplatte führen, wie folgt durch je eine Drosselspule gebrückt. Von links zählend lötet man über die Löt-punkte 2+3 und 5+6 jeweils eine Drosselspule o.g. Typs.

Danach muß noch der gelbe vom Mikrofon zum Verstärkereingang führende Draht verdrosselt werden. Am besten geschieht dies dadurch, indem man direkt hinter der Buchse, an die das Mikrofonkabel geführt wird, auf der Platine die Leiterbahn zum Verstärkereingang unterbricht und über diese Unterbrechung ebenfalls eine Drosselspule o.g. Typs lötet.

Werden die Drosselspulen mit kurzen Anschlußdrähten liegend auf der Platine plaziert, so läßt sich anschließend die Platine problemlos wieder einbauen.

Nach dieser kleinen preiswerten Modifikation waren bei mir die HF-Einstrahlungen auf allen 9 Amateurfunkbändern gänzlich verschwunden und ich habe diese triviale Änderung noch bei zwei anderen Mikrofonen gleichen Typs erfolgreich durchgeführt. Eine Unterbrechung der bei diesem Mikrofontyp viel zitierten Masseschleife führte in meinem Fall zu keinem Erfolg.

This modification is read 1897 times.

[top of page](#)

20-08-2000

(MC-60) Kenwood MC-60 Microphone Mod (Connect to ICOM IC-746)

At a Ham Fest last year I purchased a Kenwood MC-60 microphone with the intention of using it with my ICOM IC-746 transceiver. Figuring out the microphone and PTT connections was pretty straight forward. However making the Up and Down switch work with my ICOM was not that straight forward. Kenwood uses separate lines for the Up and Down functions while ICOM uses one. Having other things to do at the time, I simply hooked up the microphone and the PTT switch and used it without the Up/Down function.

Now I'm sorry I took so long to get back to the project. After doing some investigation I figured out (using the original ICOM microphone) that the Up function on the ICOM was achieved by grounding pin 3 on the ICOM microphone connector. The Down function was done by grounding pin 3 through a 470 ohm resistor. The solution was simple. Add a 470 ohm resistor across pins 3 and 4 on the back of the connector in the base of the MC-60 and connect pin 4 of the microphone to pin 3 on the ICOM.

Function	Ken	Icom
Mic Audio	1 — YEL	1
PTT	470 2 — BLK	5
Down	3 — BLU	N/C
Up	4 — RED	3
+8V	5 — GRY	2
Rev Audio	6 — ORG	N/C
Mic Gnd	7 — SHD	7
PTT Gnd	8 — GRN	6

Kenwood MC-60 to ICOM 746
David M. Hitchner KD5EIS

David M. Hitchner - hitchner@home.com

Baton Rouge, LA

KD5EIS - kd5eis@arrl.net.MODIFICATION.NET

Baton Rouge Area Scanning

This modification is read 1732 times.

[top of page](#)

17-08-2001

(MC-60) Remove RFI in the MC60

Author: DA1LDN - da1ldnjm@surfeu.de. [MODIFICATION.NET](http://www.MODIFICATION.NET)

Here's a simple solution to delete the rfi in the mc60.

I had this problem on 10m and sometimes on 15m. Only when the beam turned to a certain direction and when the processor is put on.

I didn't want to make soldering (capacitors) into the microphone. So I just put a ferrit baton (5 cm long) in each extremity of the spiral microphone cable and it works well. Now all is ok and the ferrit baton are hidden with the spiral. Simple and easy!

Good luck!
DA1LDN-ON4JM

This modification is read 2184 times.

[top of page](#)

19-07-1998

(MC-85) Mod for MC-85 MIC and RC-1A phone

I am a Ham Radio Operator (call signed 4Z4MJ). My station is exclusively Kenwood (TS-940s, TL-922, TR-2400, TR-7950, MC-85, and the PC-1A phone patch) and I'm very content of having the honor to belong to the Kenwood family.

In Israel, I work as an electronic design engineer and on my free time, I'm always anxious to solve design problems and add my own modifications to the shack. I would like to present you the modifications I have made and hope they might be helpful. (The mods deal with the MC-85 microphone and the PC-1A phone patch; I enclose them with this letter and emphasize the changes with the yellow marker, So let's start.....

When I purchased my TS-940S with the MC-85 microphone, I was very happy with the 940 but sad about the 85. The problem was R.F. feedback when I was touching the microphone's goose-neck with my hand, (or when the linear was on, it happened without even having to touch the mic).

Not only that, I was not able to function the S-201 (mic selector of the MC-85) if I was connecting more than one rig to the MC-85. At first I thought my MC-85 is malfunctioning, but from talking with five other hams in Israel who own the MC-85, I heard that they all suffer the same problems!!

The main problem was caused because of a ground loop. There were two (2) grounds to ECM unit (you know it's illegal). The ground on the p.c. near the Q1 transistor is absolutely fine, but what about the one that makes a ground connection between the ECM unit and the top of the goose neck? The solution is described on the enclosed paper marked (1). The addition of (2) and (3) were needed to give more R.F. attenuation to the common mode and to the differential mode rejection respectively.

In summary, (2) and (3) are necessary but (1) is a MUST. These mods cured completely all the RF feedback problems that one can have with the MC-85. Before closing the microphone's base cover, I added a few more mods. I hope they are clear from the modified scheme and the notes. (Notice that all these mods can be done without having to remove the printed circuit board.) A similar thing happened with the PC-1A phone patch...started because of a "serious" problem and ended with extra "very helpful" mods.

The "serious" problem was that no matter how loud I put the RX gain control, there was never enough audio to the telephone line, and not only that, the audio was distorted! (See IRI of April, 1987, Issue No. 64, Page K64, where C.M. Luchessa WN6O, suffers a similar problem and asks: "Any remedial information will be appreciated".) The problem was solved by changing D5 and D6 (originally they were clipping the audio at 0.7 volts). I made the change by putting 3 silicon diodes on each leg, so now the clipping is done above 2 volts, and not at 0.7 volts, R11 was changed from 27 to 10 ohms. Again, before closing the patch's cover, I added a few more mods.

A. I couldn't work vox properly with the PC-1A because I couldn't null deep enough the bridge. VR1 was partly nulling at the far end of it's position. Adding a 1.5k ohm in parallel with R5 (or alternatively just changing R5 to a single 470 ohm resistor) brought the null to the mid-position of VR-1.

B. Although the null is now centered, it was not deep enough. Adding on 0.1 uf disk capacitor in parallel with RF balanced the reactive component of the bridge, the null became extremely sharp!

C. An addition of a high pass filter to the patch that gives the same effect as the "low cut" position on the MC-85 microphone was "very helpful" when the PC-1A was connected to the SSB HF ring. The filter is simply made of a 10K ohm resistor and an 0.02 uf capacitor. (see it on the modified scheme (next month)).

With all the changes I made to both the PC-1A and the MC-85, I'm most satisfied and I would very much like to hear your remarks (maybe published in the I.R.I. too!).

The instructions not is complete. Where the instructions number 1, 2 and 3 ??

This modification is read 1278 times.

[top of page](#)

03-02-2001

(MC-85) Connect Kenwood MC-85 to Yaesu FT-100

Author: Björn Karlsson - bjorn.dunder.karlsson@mail.bip.net. [MODIFICATION.NET](#)

Connect other microphone to Yaesu FT-100.

Here´s a description on how connect Kenwood MC-85 to Yaesu FT-100

It was problems was PTT switch shall connect.

Here below does I a description how microphone shall connect to radio and which components that be needed.

Components

A: = 82 Kohm

B: = 39 Kohm

C: = 27 Kohm

82K be needed to Up switch

39K be needed to Down switch

27K be needed to PTT switch

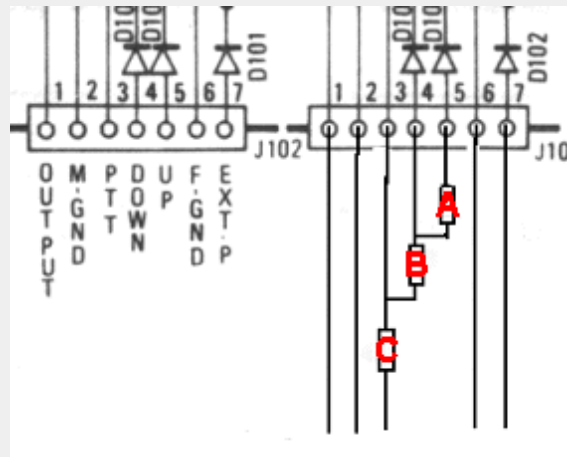

Kenwood MC-85 5 4 6 4 3 <->Connect to digits in modular
Connection. (2 and 6 connect along
 in the mic Before the connect to pin 4
 in modular connection.)

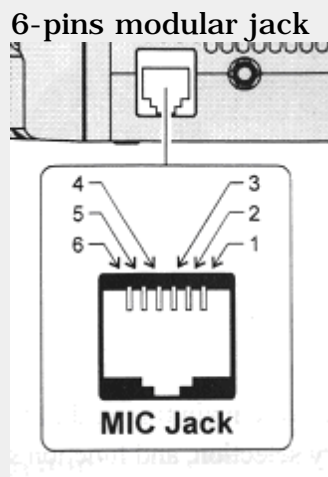

Mic-jack Yaesu FT-100 / 90 / 8100.

- Pin 1:** SW 2 multi-function switching
- Pin 2:** N.C. (9600bps packet data output FT-90)
- Pin 3:** + 9 v
- Pin 4:** GND
- Pin 5:** Microphone Input

Pin 6: SW 1 PTT, UP och DOWN

73 Bjorn SM5SWI

This modification is read 1148 times.

[top of page](#)

19-07-1998

(PS-430) No protection on Powersupply

Hallo Guys.

I had have some problems with originale Kenwood Powersupply (PS-430) The final-solid-states has brooken on it, so absolutly no protections on this Equipment, and the full 24V DC came to my rig. And i seen it only when the ventilator beginns to run, (faster as usual) so some minutes i had 24V on my TS-690S , because the display on this Rig has no usual scale-lamps.

But it seem to be, no dommage on the Rig detectable for the moment.

When i repaired than the supply i made a little change on it. So take a look on your Powersupply iff they has an overvoltageprotection, iff not you can use following very simple, but sure circuit.

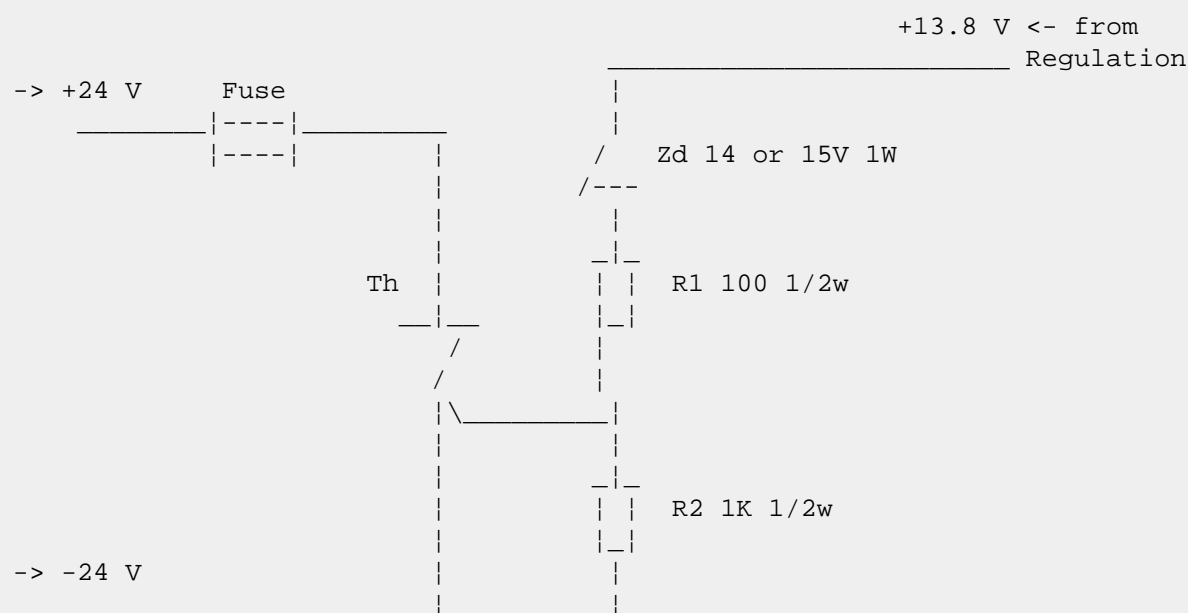

Explication :

Iff the Outputvoltage (13.8V) came over the Zenerdiode + the ignition-voltage from the Thyristor, this will be Shortcircuit the +24V and the - So the fuse will be smelting, and no dommage on your Equipment.

Important the fuse and the Thyristor must been adapt to your Power, not that the Thyristor are broking and the fuse not.

This modification is read 657 times.

[top of page](#)

16-04-2000

(PS-430) PS-430 Voltage increase with TH-205/215

Author: Trio-Kenwood Communication, inc.

Service Bulletin no. 938 (2-6-1988)

When the PS-430 is used as an external D.C. power supply for the TH-203/215, the output voltage may increase to approximately 20V due to RF feedback. This condition is restricted to operating in the high power mode with the supplied helical antenna. Adding a by-pass capacitor between the base and emitter of Q2 on the AVR board of the PS-430 will correct this occurrence.

Required parts:

1000 pF, 50V capacitor (CK45B1H102K)

1. Remove power from the PS-430.
2. Remove top cover of the power supply (10 screws).
3. Locate transistor Q2 on the upper left hand side of the AVR board (X43-1440-00). The transistor and thermistor TH1 are covered with a piece of shrink tubing to keep them in close contact with one another.
4. Remove the shrink tubing from Q2 and TH1.
5. Tack solder a 1000 pF capacitor between the two outside leads of Q2 (base and emitter).
6. Reinstall the shrink tubing (if it no longer fits, just make sure that the thermistor is in physical contact with the transistor).

7. Reinstall the top cover.

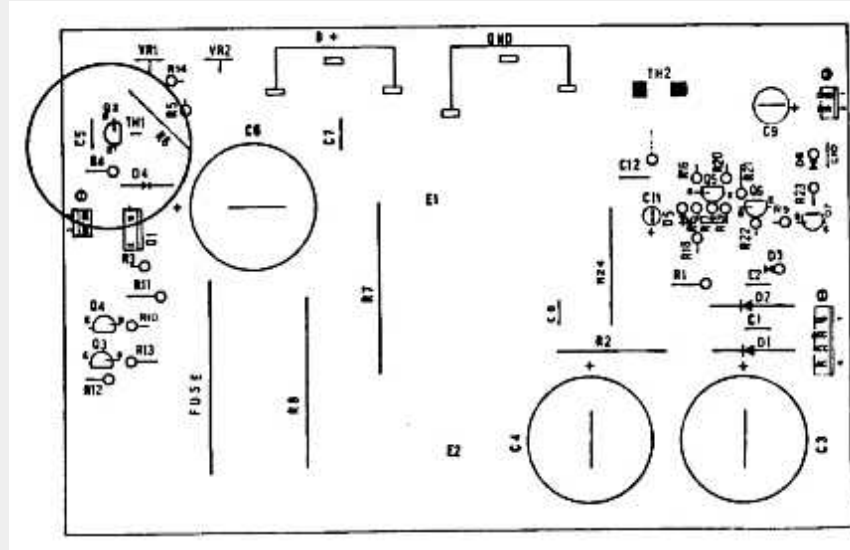

This modification is not covered under warranty.
Time required for this modification is 1/2 hour or less.

This modification is read 628 times.

[top of page](#)

19-07-1998

(PS-50) PS-50 Improved Voltage Surge Protection

Author: Trio-Kenwood Communication, inc.

Service Bulletin no. 914 (23-5-1986)

We have received a few reports regarding the loss of transistor Q4, resistors R2, and R3, and zener diode D4 on the AVR UNIT. Apparently a voltage surge on the power input might cause D4 to short. If this occurs the surge current thru resistors R2 and R3 could be high causing the failure of the two resistors and Q4.

Procedure:

On the AVR unit X43-1520-00 open or remove diode D4.

If you receive a unit with no output voltage check D4, R2, R3 and Q4. You should replace R2, R3, and Q4 if there is any sign of damage to any of these components.

This change applies to serial numbers before 7040001.

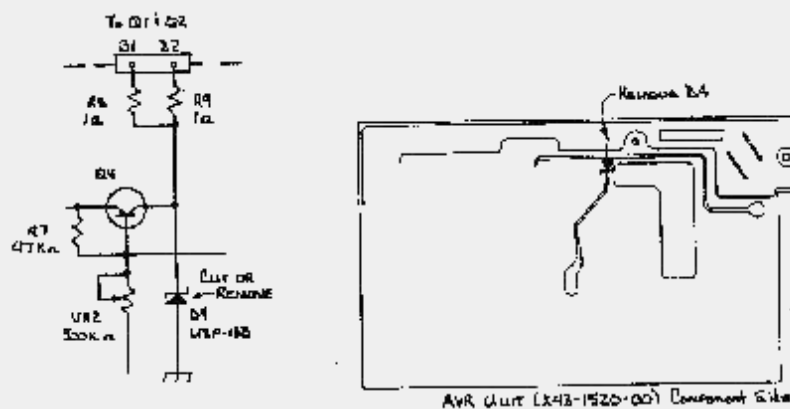

Time required for this change is 1/2 hour or less.

This modification is read 474 times.

[top of page](#)

12-02-2000

(QR-666) QR-666 VFO stability

Author: Trio-Kenwood Communication, inc.

Service bulletin no. 3 (10-01-1975)

Trio-Kenwood is extremely proud of the reliability of our communications gear. Quality control is performed at our Toykyo factory as well as Gardena, California facility.

We have found that a small percentage of the QR-666 SWL receivers may have a slight case of instability if carelessly handled in shipping.

Here is a simple cure we've found to eliminate the symptoms:

Check all screws which hold the RF circuit board (the one with band switch attached). Check top and bottom screws (holding spacers to chassis).

You'll probably never have this problem, but.....

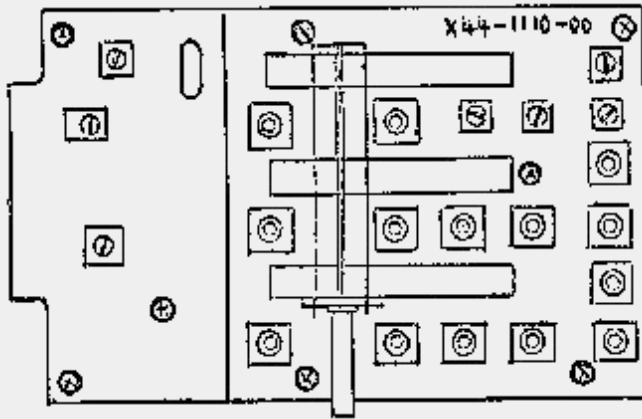

This modification is read 278 times.

[top of page](#)

19-07-1998

(R-1000) Kenwood R-1000 muting

Author: Trio-Kenwood Communication, inc.

Service Bulletin no. 805 (7-2-1980)

Mute Circuit:

The R-1000 has a mute circuit four use in combination with a transceiver or transmitter.

The R-1000 RF stage will mute by grounding pin 7 on the remote terminal.
(See Fig 3-9) in the operators manual.

This information was inadvertently omitted from the Owners Manual, and will be included in manuals for serial number 0030502 and above.

This modification is read 786 times.

[top of page](#)

19-03-2000

(R-1000) R-1000 AGC, AM bandwidth changes

Author: Trio-Kenwood Communication, inc.

Service Bulletin no. 813 (19-2-1980)

AGC

To shorten the AM AGC time constant, C2, the AGC capacitor may be changed from the original 4.7uF, or simply delete C2 by clipping out the 4.7uF as supplied. Access to this component is by removing the top case. On early models, C2 is located behind the MODE switch, and on later models, is located on the RX unit as C138 adjacent to connector 13.

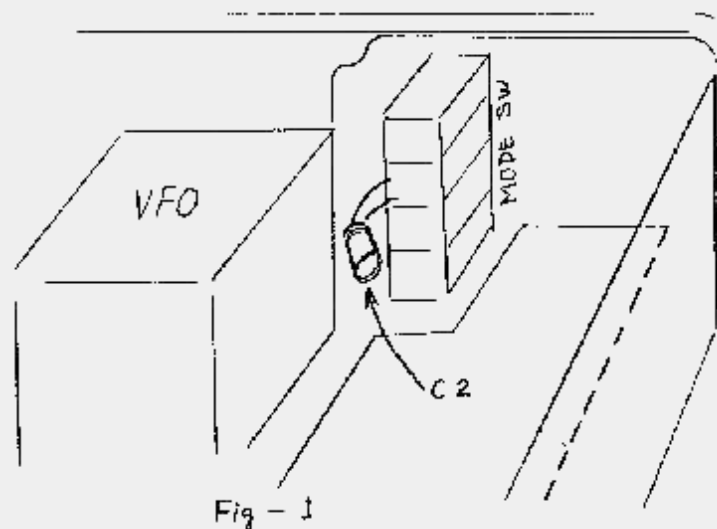

AM Bandwidth optional wiring

If you desire substituting the AM 6KHz filter in favor of the 12KHz for AM WIDE, and the 2.7KHz filter for AM narrow, install the optional BWK-1 connector kit (see reverse) in-line at connector 3 on the RX unit X55-1250-00.

24 HR clock

Contrary to popular rumor, the clock module IS NOYT convertible to 24 hour format.

BWK-1

The BWK-1 is an optional AGC and Narrow bandwidth kit for early production R-1000 receivers. It allows using the SSB 2.7KHz filter for AM narrow, and includes a 1uF cap for shortening the AGC time constant. This kit includes instruction to fabricate and install the connector and to locate and replace the cap. This does require some technical ability.

This kit is for serial numbers before: 0030001-0051600 & 0060001-0060400 cap change and before serial numbers 010xxxx for selectivity. Later production has the 1uF cap, and internally selectable AM bandwidth.

Contents of this kit:

1. Diode
1. Male connector 3 pin
1. Female connector 3 pin
2. Female connector pins
1. 1uF @ 16V (or greater) capacitor
1. instruction sheet

Additional Requirement

- 45 Watt or smaller soldering pencil.
- 60/40 rosin core solder
- small cutting plier
- #2 Philips screwdriver

Installation:

Install as outlined on the reverse side of the instruction. Disconnect power before opening the R-1000.

Connector fabrication read before proceeding.

1. Cut the leads on the diode to approximately 3mm or 1/8 inch, and save the cut leads.

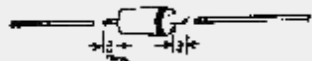

2. Lay the connectors diode, leads and female connectors out just as pictured. Be sure the index on the diode and each connector is as shown:



3. Solder the diode and leads the Female connector pins.
4. Insert the Female connector pins in the Female connector so the metal tabs lock into the plastic connector.



5. Solder the diode and leads to the Male connector. Fabrication is complete.

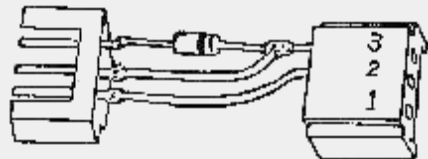

19-03-2000**(R-1000) R-1000 RF attenuator 10 dB step option****Author:** Trio-Kenwood Communication, inc.

Service Bulletin no. 823 (22-4-1980)

The RF Attenuator may be converted from the standard 20 dB step to 10 dB by replacing resistors on the RX unit X55-1250-00.

Replace	With	Type
R1	No Change	
2	R3 1.2K	R (Radial)
3	1.8K	R
4	R7 1.2K	A (Axial)
5	4.7K	A
6	15K	R
7	1.8K	A
8	1.2K	R
9	No Change	
10	R16 56ohm	A
11	No Change	R
12	100 ohm	A
13	68 ohm	A
14	R13 220 ohm	A
15	820 ohm	A
16	100 ohm	A
17	No Change	R
18	R12 56 ohm	

Note: How to Solder on the PC Board.

1. Use a LOW POWER PENCIL, 35W or less.
2. Use rosin cone solder, small diameter.
3. Do NOT create solder bridges or splotches.
4. Do NOT overhead or otherwise lift the foil from the board.
5. Wash excess flux away with RESH trichlor, and a small flux brush. Neatness counts- It's YOUR radio.

19-07-1998**(R-5000) Kenwood R5000 Modification Notes**

The following describes some option jumpers and other features I have found in the Kenwood R-5000 receiver.

The R5000 is fairly delicate internally, so you should not undertake these modifications if you are not fairly confident of your ability to work with delicate electronics (or to repair it if necessary). In particular, the receiver's numerous circuit boards are connected together with wire harnesses made of relatively fine and delicate wires. Also, some of the boards (particularly the IF board) have small "daughter boards" containing small surface mount parts vertically attached to the main board. These are also fairly fragile, and caution is required in handling them.

EXPANSION FEATURES

The R5000 has six "Expansion Feature" options which are not documented in the user manuals. These are controlled by jumpers (actually diodes) on the CPU board, which is attached to the back of the receiver's front control panel, underneath a metal RF shield. Unfortunately, you must completely remove the receiver's covers, and unfasten the front panel, in order to access these.

Gaining Access to the Jumpers

To access the jumpers, remove the top and bottom covers of the receiver by removing the eight silver screws which hold each cover in place. Use caution at this point, since the radio will be sitting only on its internal chassis, and delicate parts will be exposed.

Next, remove the four flat silver screws which were *under* the covers (NOT the black screws that are visible with the covers on) which hold the front panel onto the main chassis. Be sure the receiver is sitting on a solid table so that the front panel will not fall off

when you do this, since there are a large number of wire harnesses connecting to the CPU board. Very carefully pull the front panel forward and rotate it so that you can get access to the back of the front panel.

Loosen the five small metal screws (two at the top, three at the bottom) which hold the RF shield in place over the CPU board. The holes in the shield the screws go into are slots, which allow you to slide the shield off without removing the screws completely. This is fortunate since the screws are fairly small. Remove the RF shield.

One other thing to note involves installing the optional filters.

First, I found that the AM filter which came with the radio introduced a whistle into most AM signals. I replaced it with the optional AM filter, and it eliminated the whistle (and gave a "fuller" sound to the AM).

Also, note that if you install other filters, you have to install them "in order" -- in other words, the narrowest has to go in the N position, the next narrowest in the M1 position. Note that the M2 position is already occupied (as shipped) by a high-quality SSB filter. The reason they have to be in order is that as you select narrower and narrower filters, the wider filters remain in the circuit, so if you put a narrower filter in M1 than you have in N, it will stay enabled even when you select the wider filter, causing the wider filter to have no effect.

It's a little unfortunate that it works that way, since the M1 filter is only enabled by the switch (not in AUTO mode), which would be ideal for the very-narrow YK88CN filter. I have identified a modification to make M1 be selected only when the switch is in the M1 position; it involves disconnecting 1/2 of a dual diode and soldering a diode between two prod the PK232.

This modification is read 1027 times.

[top of page](#)

19-07-1998

(R-5000) R-5000 No Freq. Change thru Computer Interface

Author: *Trio-Kenwood Communication, inc.*

Service Bulletin no. 919 (21-7-1987)

R-5000 receivers below serial number 804xxxx may not change frequency when operated with a personal computer/interface. To allow correct operation, rplace IC-52 on the Control Unit. The correct part number for IC-52 is MBM27C128-25JA2.

CAUTION:

The R-5000 incorporates CMOS technology. Observe precautions for handling electrostatic sensitive devices.

This modification may be performed under warranty.

Time required for this change is 1/2 hour or less.

This modification is read 896 times.

[top of page](#)

27-02-2000

(R-5000) Increase the MW sensitivity for R-5000

This modification increases the MW sensitivity of the Kenwood R-5000:

This will help for MW DX or while using a loop antenna when more gain can be useful. All mods are performed on the RF board, on the side nearest to the antenna connectors.

Jumper R10 with a short length of wire, and cut R11. Cut R9 and put a 470 Ohm resistor in series.

A quick version of this modification is to clip either one [NOT BOTH] of R9 or R11.

This modification is read 928 times.

[top of page](#)

13-02-2000

(R-599) Service Notes on R-599A/D

Author: Trio-Kenwood Communication, inc.

Service bulletin no. 8 (2-11-1977)

1. VFO Drift: Bad Q1 3SK22(Y) (40-0016-18). Also change R1 270K to 1M Q1 bias.
2. Low sensitivity: Check Q1 3SK22(GR) (X44-0020-00).
3. No Tranceive operation: Check for dirty contact of tranceive switch or broken wires at switch.
4. Receiver sensitivity: Q4 2SC733(Y) on IF unit (X48-0011-00).
5. No receive with tranceive switch in the TX or reverse: Check for cut coax at VFO terminal of IF unit (X48-0011-00).
6. No VFO receiver: Check L3 at Q1 in VFO (X40-0016-00).
7. Receiver 10 to 20 dB down: Check protection diodes D1, D2 1N60 at (X44-0020-00).
8. FM doesn't work: Check T8 discriminator transformer on (X48-0011-00).

This modification is read 655 times.

[top of page](#)

19-02-2000

(R-599) Removing CB Band from R-599A/D

Author: Trio-Kenwood Communication, inc.

Service bulletin no. 31 (15-3-1978)

One of the items in the FCC's expansion of the CB band to 40 channels was to require all receivers that have a specific CB or 11 meter band be type accepted.

The R-599A and R-599D receivers have not been type accepted and we do not plan to have this done as they are designed for the ham bands. We have therefore removed the CB position from the current production of R-599D receivers and this band position is now labeled AUX.

This ruling also applies to any used R-599A or R-599D receiver you may have in stock. The following instructions are for removing the CB band. This will satisfy the FCC and make the receiver saleable.

1. Remove top cover.
2. Remove bottom cover.
3. Remove shield plate from coil pack.
4. Set band switch to 14 MHz.
5. Remove the black wire from the OSC coil Unit. (This wire is on the top side.)
6. Loosen screws on shaft coupling and slide shaft out about 2 inches.
7. Unsolder the OSC coil Unit from the mounting bracket and remove it from the coil pack.
8. Unsolder and remove the CB coil and crystal.
9. Replace the OSC Coil Unit and solder it in.
10. Slide the band switch shaft in place, making sure that each wafer is properly indexed.
11. Resolder the black wire to the OSC Coil Unit.
12. Replace all cover.
13. Check for prpper operation.

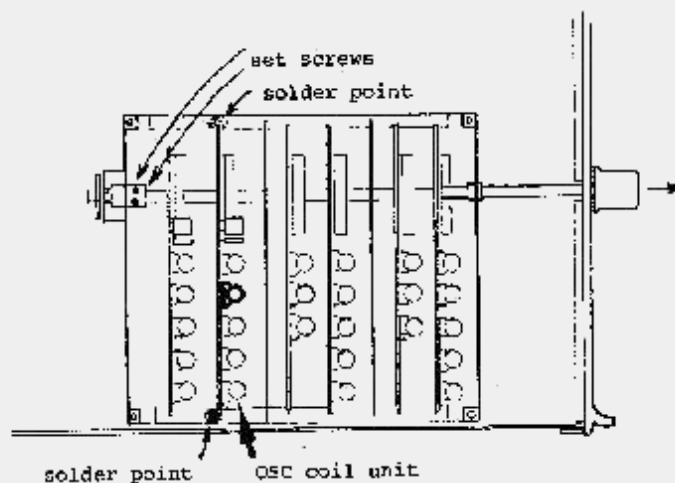
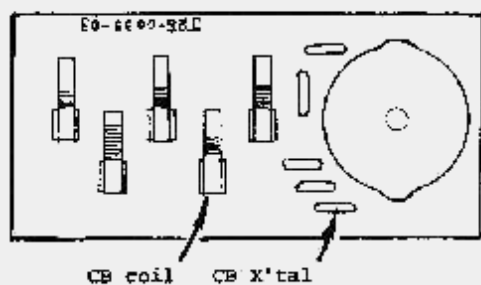

This modification is read 599 times.

[top of page](#)

(RC-10) RC-10 Hang up time/timeout timer settings

Author: Trio-Kenwood Communication, inc.

Service Bulletin no. 922 (2-11-1987)

The RC-10 hang up time and timeout timer (Cross-Band Repeater function) are preset at the factory for three seconds and three minutes respectively. Should it become necessary, the RC-10 can be following procedure will allow the user to select the best setting for his requirements.

Procedure:

1. Disconnect the RC-10 from all other equipment.
2. Using a thin plastic tool, remove the KENWOOD badge from the handset.
3. Underneath the badge are two holes in the handset. Remove the machine screw from the left hole.
4. At the bottom of the handset locate two small holes in the plastic molding (see figure 1). Press a narrow alignment tool into both holes and pry the handset apart (be careful not to break the short wires inside).
5. Remove the PTT and AF level knobs.
6. Remove the three 3 x 6 mm machine screws that secure the metal shield to the handset.
7. Lift the AF unit and shield to expose the Keyboard assembly.
8. Locate resistors R8 - 11 on the Keyboard assembly (figure 2).
9. Connect the left side of the resistor to the ground side (right side) of capacitors C8 - 11. Use the timing chart and figure 2 for timing configurations.
10. Reassemble the handset. Route all wires under the cut outs on the shield. Do not pinch any wires.



FIGURE 1

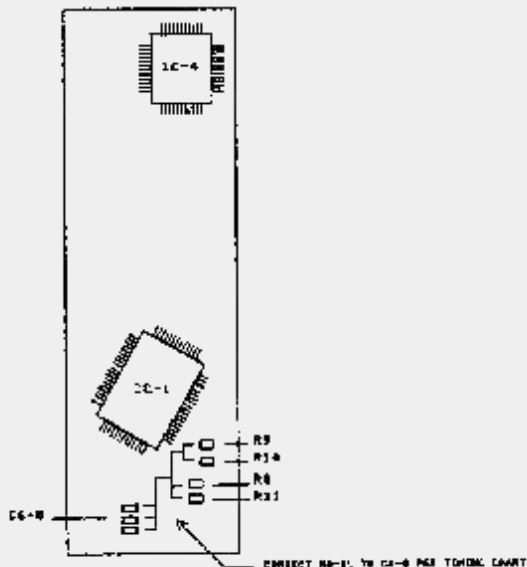

FIGURE 2

		HANG UP TIME		TIMEOUT TIMER	
		R10	R11	R8	R9
0	SEC	0	0	0 SEC	0
0.25	SEC	0	1	30 SEC	1
0.50	SEC	1	0	1 MIN	0
3	SEC	1	1	3 MIN	1

1: Do not connect to ground
0: Connect to ground

16-04-2000

(RC-10) RC-10 Alternator noise

Author: Trio-Kenwood Communication, inc.

Service Bulletin no. 927 (28-10-1988)

When two transceivers are connected to the RC-10, alternator noise may be induced in the mic circuits. The following modification will correct this condition.

Parts required:

600 ohm isolation transformer	W05-0222-00	qty 2.
470 μ H ferri-inductor	L40-471-05	qty 1.

1. Remove the base plate from the RC-10 (6 screws on the plate; 1 screws on the back panel).
2. Add the ferri-inductor between pins 7 and 8 of the connector B as shown below.
3. Locate connectors J2 on the AF unit (X49-3010-XX B/3).
4. Add a transformer in each mic circuit as shown below.
5. Using double sided tape, secure each transformer to the side wall on the base.

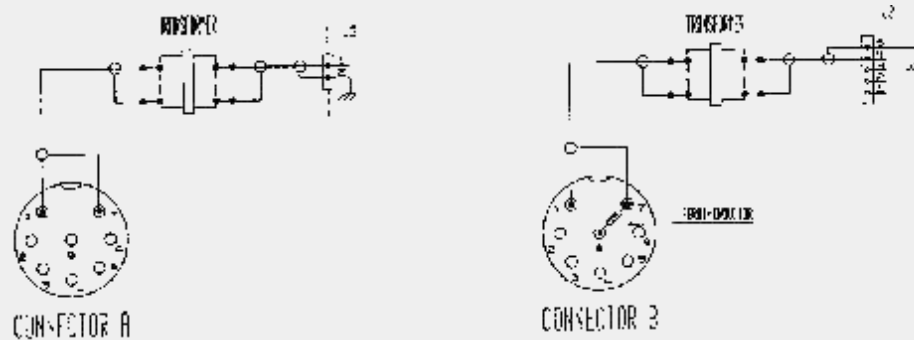

This modification may be covered under warranty.
Time required for this modification is ½ hour or less.

This modification is read 469 times.

[top of page](#)

19-07-1998

(RC-1A) Mod for MC-85 MIC and RC-1A phone

I am a Ham Radio Operator (call signed 4Z4MJ). My station is exclusively Kenwood (TS-940s, TL-922, TR-2400, TR-7950, MC-85, and the PC-1A phone patch) and I'm very content of having the honor to belong to the Kenwood family.

In Israel, I work as an electronic design engineer and on my free time, I'm always anxious to solve design problems and add my own modifications to the shack. I would like to present you the modifications I have made and hope they might be helpful. (The mods deal with the MC-85 microphone and the PC-1A phone patch; I enclose them with this letter and emphasize the changes with the yellow marker, So let's start.....

When I purchased my TS-940S with the MC-85 microphone, I was very happy with the 940 but sad about the 85. The problem was R.F. feedback when I was touching the microphone's goose-neck with my hand, (or when the linear was on, it happened without even having to touch the mic).

Not only that, I was not able to function the S-201 (mic selector of the MC-85) if I was connecting more than one rig to the MC-85. At first I thought my MC-85 is malfunctioning, but from talking with five other hams in Israel who own the MC-85, I heard that they all suffer the same problems!!

The main problem was caused because of a ground loop. There were two (2) grounds to ECM unit (you know it's illegal). The ground on the p.c. near the Q1 transistor is absolutely fine, but what about the one that makes a ground connection between the ECM unit and the top of the goose neck? The solution is described on the enclosed paper marked (1). The addition of (2) and (3) were needed to give more R.F. attenuation to the common mode and to the differential mode rejection respectively.

In summary, (2) and (3) are necessary but (1) is a MUST. These mods cured completely all the RF feedback problems that one can have with the MC-85. Before closing the microphone's base cover, I added a few more mods. I hope they are clear from the modified scheme and the notes. (Notice that all these mods can be done without having to remove the printed circuit board.) A similar thing happened with the PC-1A phone patch...started because of a "serious" problem and ended with extra "very helpful" mods.

The "serious" problem was that no matter how loud I put the RX gain control, there was never enough audio to the telephone line, and

not only that, the audio was distorted! (See IRI of April, 1987, Issue No. 64, Page K64, where C.M. Luchessa WN6O, suffers a similar problem and asks: "Any remedial information will be appreciated".) The problem was solved by changing D5 and D6 (originally they were clipping the audio at 0.7 volts). I made the change by putting 3 silicon diodes on each leg, so now the clipping is done above 2 volts, and not at 0.7 volts, R11 was changed from 27 to 10 ohms. Again, before closing the patch's cover, I added a few more mods.

A. I couldn't work vox properly with the PC-1A because I couldn't null deep enough the bridge. VR1 was partly nulling at the far end of it's position. Adding a 1.5k ohm in parallel with R5 (or alternatively just changing R5 to a single 470 ohm resistor) brought the null to the mid-position of VR-1.

B. Although the null is now centered, it was not deep enough. Adding on 0.1 uf disk capacitor in parallel with RF balanced the reactive component of the bridge, the null became extremely sharp!

C. An addition of a high pass filter to the patch that gives the same effect as the "low cut" position on the MC-85 microphone was "very helpful" when the PC-1A was connected to the SSB HF ring. The filter is simply made of a 10K ohm resistor and an 0.02 uf capacitor. (see it on the modified scheme (next month)).

With all the changes I made to both the PC-1A and the MC-85, I'm most satisfied and I would very much like to hear your remarks (maybe published in the I.R.I. too!).

This modification is read 241 times.

[top of page](#)

18-03-2000

(RM-76) RM-76 Battery Back Up Power

Author: Trio-Kenwood Communication, inc.

Service Bulletin no. 59 (14-12-1979)

To retain memory in the RM-76, an optional DC Cable and usersupplied battery may be used. This would be useful where transferring the unit Base to Mobile, or when operating on an AC supply which cannot be run continuously.

Connect a DC Cable assembly, E30-0220-05, as illustrated. This will connect at the RM-76 rear panel.

Battery recommendation is 7.5V DC.

Current drain is less then 50mA at memory on.

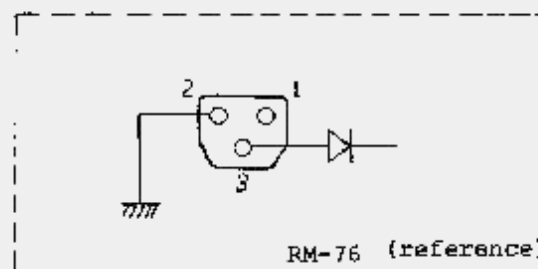

This modification is read 425 times.

[top of page](#)

18-03-2000

(RM-76) RM-76 Microprocessor failure

Author: Trio-Kenwood Communication, inc.

Service Bulletin no. 802 (8-2-1980)

When servicing an RM-76 for IC5 failure, also check pin 39 vdd voltage which should be approximately 6 V DC. Higher voltage will lead to premature second failure. An incidental symptom for this problem would be such reports as all "8's" before total failure.

Replace IC5 and IC2, NJM78L06A, the 6V regulator for the Microprocessor. Also check IC1 FS7806M, which supplies regulated 6V for all other sections. Failure of this regulator (at about 10V DC) will give all logic hi's.

This modification is read 427 times.

[top of page](#)

18-03-2000

(SM-220) SM-220 Shield Installation

Author: Trio-Kenwood Communication, inc.

Service Bulletin no. 57 (30-11-1979)

For Sweep interference from the SM-220 back into either a TS-520 or TS-180S, install an additional shield in the RF compartment in the SM-220.

1. Disconnect the power cord from the back of the scope.
2. Remove the scope top cover.
3. Loosen the function and RF ATT shaft couplers using a 1,5 mm allen key. Withdraw the shafts away from the RF compartment.
4. Remove RF compartment screws from the rear panel.
5. Remove 4 screws to open the RF comp.
6. Remove one screw to remove internal shield.
7. C6, a .01uF. runs from the Function Switch to a ground point under the RF ATT switch. Cut the ground lead and shorten so the cap is grounded to the ground point under the Function Switch.
8. R2, a 10 Kohm, is attached to the terminal strip directly under the Function Switch. Reposition this resistor from the top of the terminal strip the bottom of the strip.
9. Install the additional shield to the ground point under the Function Switch.
10. Reverse disassembly procedure to reassemble.

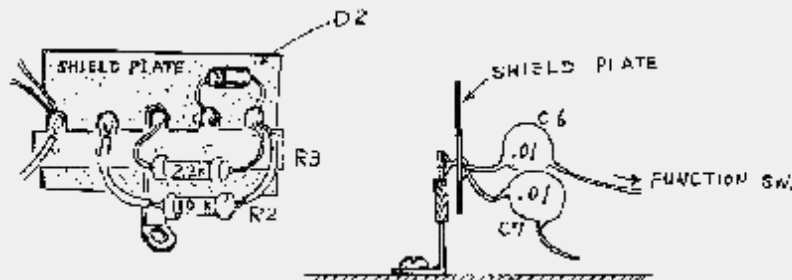

This modification is read 768 times.

[top of page](#)

18-03-2000

(SM-220) Feedback Between Pan display and IF Out

Author: Trio-Kenwood Communication, inc.

Service Bulletin no. 66 (25-7-1978)

We have found a few cases of feedback when the pan display option was installed in the SM-220 Station Monitor. This is due to the isolated ground of the BS-5 or BS-8 pan display option.

It may be remedied by grounding the case of the input transformer in the BS-5 or BS-8 to the case. (See drawing below.) This change will be incorporated in all future delivered of the BS-5 and BS-8.



This modification is read 730 times.

[top of page](#)

20-04-2000

(SM-230) SM-230 Bandscope attenuator

Author: Trio-Kenwood Communication, inc.

Service Bulletin no. 970 (29-5-1990)

When the SM-230 is used as a bandscope, the attenuator circuit is bypassed. Sometimes it is necessary to use the attenuator during strong signal reception or high noise conditions. The following modification will allow the attenuator circuit to function in the bandscope mode.

Required parts:

W05-0309-00 ATT SUB-UNIT

1. Disconnect the power cord patch cords.
2. Remove the top cover (6 screws).
3. Remove the Horizontal unit's mounting screw and secure the ATT sub-unit with the supplied 2.6mm screw washer.
4. Remove connector P12 from the Horizontal unit and insert it into jack P1 on the ATT sub-unit.
5. Insert connector JA from the ATT sub-unit into jack P12 on the Horizontal unit.
6. Insert the two wire plug, supplied in the kit, into jack P2 on the ATT sub-unit.
7. Solder the exposed ends of the red and the brown wires to the Panel units as shown in figure 2.
8. Solder the two jumper wires (they look like resistors) as shown in figure 2.

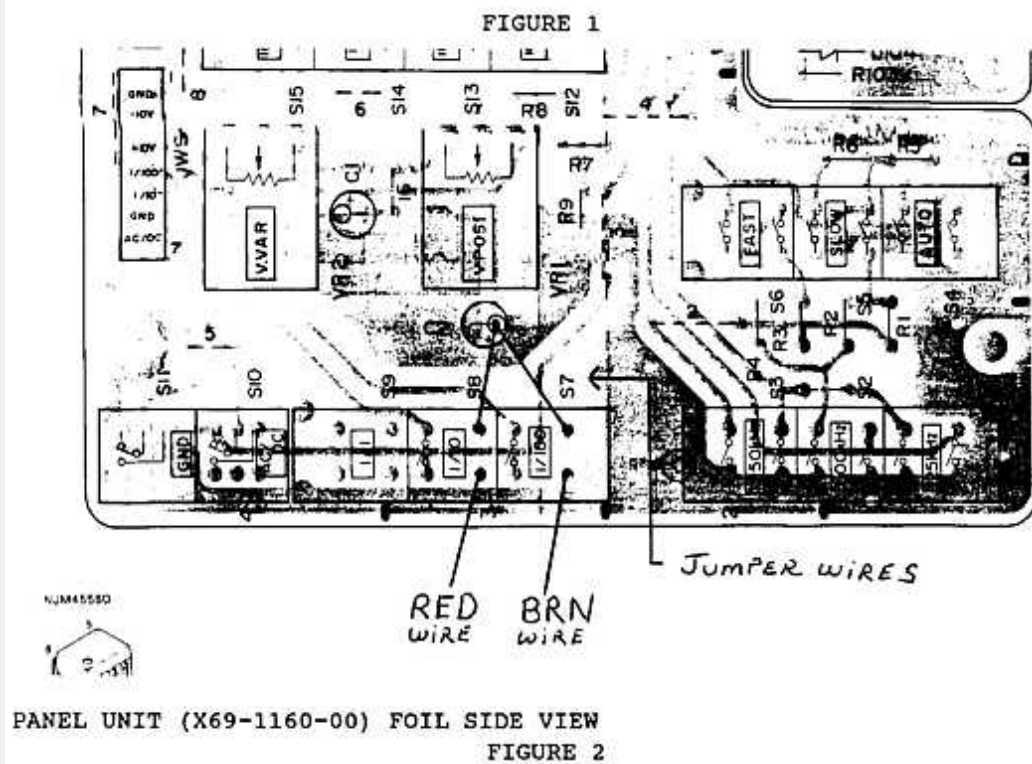
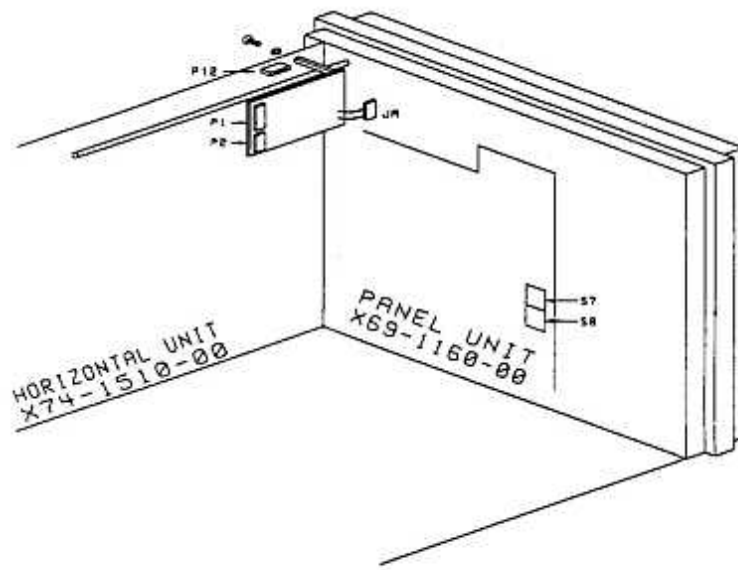

This modification may be covered under warranty.
Time required to perform the modification is ½ hour or less.

This modification is read 628 times.

[top of page](#)

21-04-2000

(SM-230) SM-230 RTTY cross pattern attenuation

Author: Kenwood Communication, inc.

Service Bulletin no. 975 (8-8-1990)

Some users of the SM-230 have reported that the MARK and SPACE gain adjustment do not sufficiently reduce the signals to display them on the CRT. The following modification will correct this condition.

Required parts:

680 ohm 1/8 watt resistor. RD14CB2B681J QTY. 2

1. Disconnect the power cord and controls cables.
2. Remove the top cover (6 screws).
3. Locate the Horizontal unit. This board is vertically mounted on the right side of the SM-230.
4. Locate resistors R318 and R322 on the Horizontal unit.
5. Replace R318 and R322 with 680 ohm resistors.
6. Assemble the SM-230.
7. Adjust the MARK and SPACE gain adjustments as necessary to obtain the correct cross pattern.

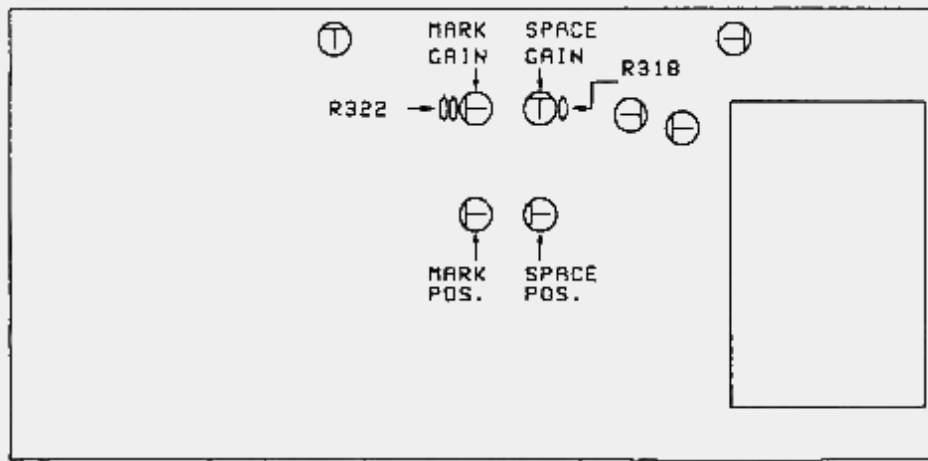

Time required to perform this modification is 1 hour or less.

This modification is read 568 times.

[top of page](#)

23-04-2000

(SMC-34) SMC-34 Distorted/muffled transmit audio

Author: Kenwood Communication, inc.

Service Bulletin no. 1031 (20 July 1993)

Symptom:

Transmit audio from the SMC-34 sounds distorted or muffled as compared with the audio provided by the transceiver own microphone.

Corrective action:

Replace the front of the microphone, add a cushion inside the microphone well and change the plastic sheet inside the microphone well.

Parts required:

Qty	Description	Kenwood Part No.	Circuit description
1	Front Case	A02-1696-18	NA
1	Cushion	G13-1397-08	NA
1	Sheet	G11-0692-08	NA

Procedure:

1. Remove the three small black Phillip's head screws from the rear of the speaker microphone.
2. Carefully remove the back cover. The "Lock Switch" lever and PTT lever can now be removed.
3. Remove the volume control knob by pulling straight away from the case.
4. Remove the two small black Phillips's head screws that secure the PC Board assembly to the front case of the microphone. You can now gently lift the PC Board assembly straight up and away from the front case.
5. Remove the packing, screen, and sheet from the front case of the speaker microphone.
6. Insert the cushion, sheet, screen and backing as shown in the accompanying illustrations.
7. Reverse steps 1 - 4 to reassemble the unit. Note: Carefully remove the rubber gasket from the old front case and position it in the new front case groove before replacing the rear case.

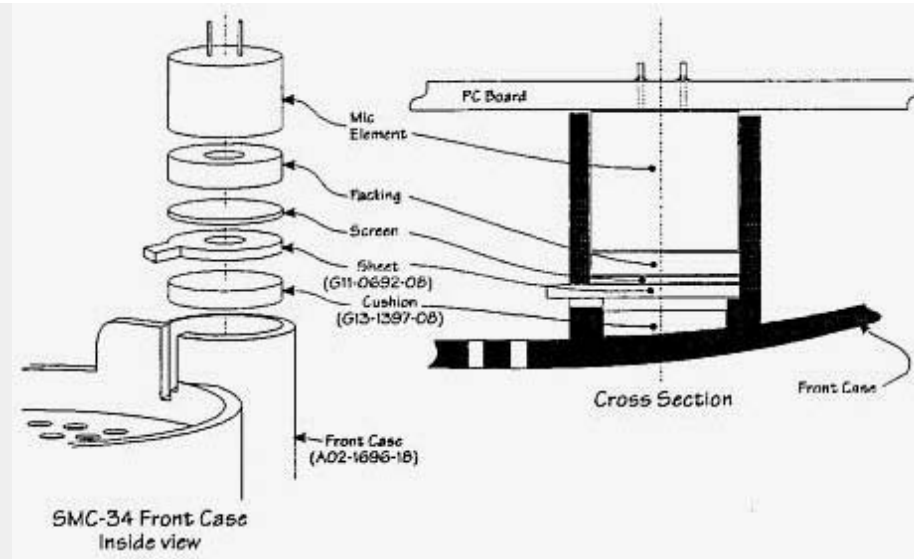

Time required for this modification is .5 hour or less.

This modification is read 390 times.

[top of page](#)

12-02-2000

(T-599) Service Notes on T-599A/D

Author: Trio-Kenwood Communication, inc.

Service bulletin no. 7 (2-11-1977)

1. *No ALC - Drive 10 meters:* Check for loose contact at oscillator wafer on coil pack.
2. *No TX any band:* Check the T1 on generator board (X52-0009-00).
3. *No TX:* Bad driver FET Q1 3SK22(GR) on X47-0004-00).
4. *No relay action when TX:* Bad Q8 2SA562(Y). When replacing Q8 change resistor R16 to 4.7 ohm.
5. *Rubber belt slipping on drive and load:* TKC has Chain Modification Kit.
6. *No drive when shock:* Check for loose output terminals af final rotary switch (S10-1002-05).
7. *No output on any band:* Check T2 GEN unit (X42-0009-00).
8. *No TX:* Check final relay for burned contacts. (S51-4017-15).
9. *Bias current too high and blows fuse:* Check for bad 6-7001A and shorted cathode resistors 10 ohm.
10. *Cannot neutralize:* Make sure shield is properly installed on driver 12BY7.
11. *No output from generator unit (X52-0009-00):* Bad Q4 TA7045.
12. *No 9 Volt out at AVR (X43-0010-00):* CHeck Q1 2SA606(L).
13. *Low output power:* If American 12BY7 is used in driver circuit, this can cause parasitic oscillation. Please use standard Kenwood replacement tubes.
14. *Blows fuse:* Check for shorted electrytics at power supply (X43-0011-00).
15. *AC hum on SSB transmission:* Send for TKC bulletin.

This modification is read 582 times.

[top of page](#)

13-02-2000

(T-599) Reducing 120Hz hum in T-599D

Author: Trio-Kenwood Communication, inc.

Service bulletin no. 17 (6-9-1977)

There have been some cases of 120Hz hum in the T-599D. This may be reduced by removing L-1 (1mH) on the generator unit (X52-0009-00) and replacing it with a 47 ohm resistor. Shown below is the generator unit board with this change.

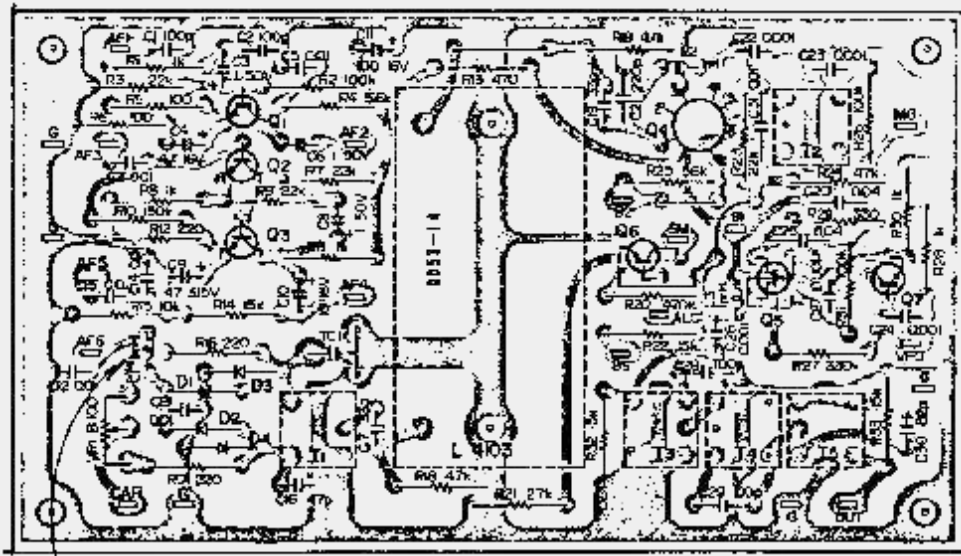

FOIL SIDE OF BOARD

L-1

This modification is read 529 times.

[top of page](#)

19-07-1998

(TF-541) TF541E & 9k6 so gehts

Hallo Kenwood-TF541E-User

hier ein Vorschlag um den TF541E am TNC2c zu betreiben .

Erst mal die Erklärung warum das gerät nicht auf Sendung geht :

Der TNC hat auf der Data-Leitung oder Signal-Ausgang zum tnc ständig eine Gleichspannung von 2 Volt anstehen . Diese 2 Volt verhindern das das Gerät auf Sendung geht .Kann man kontrollieren wenn man die Modulationsleitung ablötet und dann mit einem Packet-Programm versucht zu senden .jetzt geht es ,aber nur solange bis die Leitung wieder dran ist . wie auch beim TNC2S mit G3RUH-Modem muss auch hier die Leitung mit einer Schaltung getrennt werden .

Dazu wird benötigt :

- 1 x 74HC132
- 1x 4066
- 2 Fassungen 14 polig
- 1 Condensator 68pF (Folie oder Plattencondensator)
- ein Stückchen Lochrasterplatine und etwas Draht

Die beiden Fassungen auf die Lochraster-Platine setzen (und anlöten natürlich) jetzt festlegen in welche das 74HC132 soll und in welche das 4066

beide Chips bekommen +5 Volt auf pin 14 und Masse auf pin 7 Die Spannung kann man von der g3ruh-platine abnehmen (Highspeedleiste)

jetzt einen Draht vom Flachbandkabel (lötseite des G3RUH Pin 7+8) (PTT) zum 74HC132 (oder Fassung) auf pin1+2 löten und von pin3 zum 4066 pin 13 verbinden

Die Adern 9+10 (Modulation zum RX/TX) trennen und das Ende das vom G3RUH kommt auf den 4066 Pin 1 löten (evt mit einen Draht verlängern).

nun kommt der Condensator mit einem Bein auf Pin 2 (4066) und an das andere Bein kommt das Ende das zum Stecker geht . Die Platine kann jetzt mit einem Stückchen Teppichklebeband neben dem G3RUH im Gehäuse festgeklebt werden .Aufpassen das es keine leitenden Verbindungen zum Gehäuse giebt (Kurzschlussgefahr) .

Jetzt können die IC's in die Fassungen gesetzt werden und schon kanns losgehen

Ich habe die Schaltung in meinem TNC2S eingebaut .Bei mir wurde allerdings der Empfänger durch die Dauerspannung unempfindlich Als ich nun von DG2BAQ die Schwierigkeiten mit dem TNC2C hörte und ich die Unterlagen vom TNC2C durchsah kam mir die Idee das

es der gleiche Grund sein könnte und ich probierte es aus (siehe oben Draht ablöten usw.). Dann versuchte ich als erstes den Vorschlag nur mit dem Condensator aber das brachte nicht den vollen Erfolg .In Verbindung mit der Schaltung allerdings klappt es jetzt ausgezeichnet .

This modification is read 222 times.

[top of page](#)

19-07-1998

(TH-205) TH-205/215 Protection Fuse Replacement

Author: Trio-Kenwood Communication, inc.

Service Bulletin no. 920 (22-7-1987)

When a plug other than the PG-2V or PG-3C is inserted into the DC IN jack, the ground side of the jack may not disconnect. This may cause the external DC power to be supplied directly to the internal battery which results in overheating the battery and blowing the fuse. To protect the battery, replace the fuse with a protection diode, part number ERB83-004.

Note models with serial numbers greater than 801XXXX already incorporate this diode as D16.

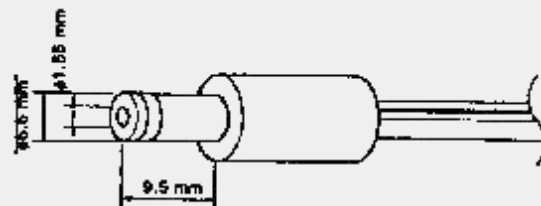

DC Plug specifications

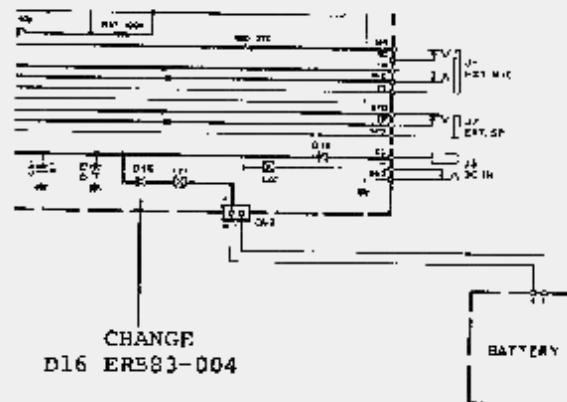

This modification may be performed under warranty.
Time required for this change is 1/2 hour or less.

This modification is read 515 times.

[top of page](#)

19-07-1998

(TH-205) 144 - 165 TX/RX mod for the TH-205

To open your th-205,215,or 225 all you have to do is take out the screws on the back, and gently open up the front of the unit... Locate the obvious 4 jumper bridges on the pc board. The bridges are numbered j-1, j-2, j-3, and j-4..Jumper j-3 has already been cut...

Carefully snip jumpers j-1 and j-2 and ever so slightly separate the snipped bridges to insure no-contact between the points.. Reassemble the unit..Look at your instruction manual and reset the microprocessor..The mod will not work until you reset the mpu... The info. For reset is near the back of the manual..After that the unit is wide open to operate between 144 to 165.

This modification is read 581 times.

[top of page](#)

06-01-2000

(TH-205) Expanding TX and RX for Kenwood TH-205

Remove rear cover from handheld, on the board you will see easily three solder links, bridge the left and the middle links.

Turn the radio back on.

This mod expands the RX more than the TX.

This modification is read 568 times.

[top of page](#)

16-04-2000

(TH-205) TH-205/215/415 Volume/squelch control improvement

Author: Trio-Kenwood Communication, inc.

Service Bulletin no. 944 (28-10-1988)

The transceivers mentioned above can be mechanically improved by adding a bracket assembly to the volume and squelch controls. The bracket assembly is being used in current production and is available for older units from the Kenwood Parts Department.

Bracket Ass'y (W05-0235-00)

1. Disconnect the battery pack and antenna.
2. Remove the 7 screws from the panel of the transceiver (Figure 1).
3. Lift the front panel from the transceiver and lay it to the right side.
4. Disconnect the 2 flex cables and remove the 3 screws from the IF unit (Figure 2).
5. Pull the top panel off and then remove the IF unit.
6. Remove the knobs and black cloth from the volume and squelch controls.
7. Inspect the controls to insure they are mounted flush to the board. If they are not flush, completely desolder and resolder the controls.
8. Insert the bracket over the controls and tighten the nuts (tighten the nut on the volume control first). See figure 3 for the bracket assembly view.
9. Assemble the transceiver by reversing steps 1 - 6.

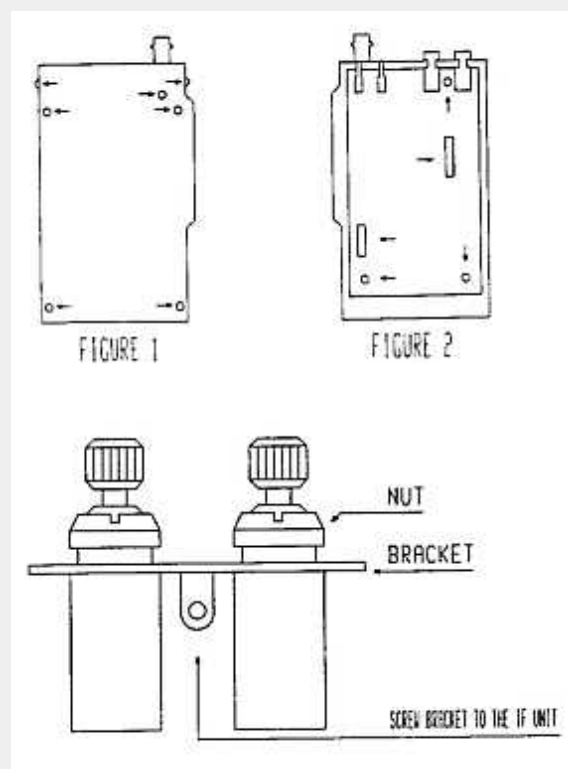

This modification may be covered under warranty.
Time required for this modification is ½ hour or less.

This modification is read 511 times.

[top of page](#)

16-04-2000

(TH-205) TH-205 Signal-To-Noise ratio improvement

Author: Trio-Kenwood Communication, inc.

Service Bulletin no. 945 (28-10-1988)

During strong signal reception, the noise level may appear to increase due to unstable action of the active filter in the PLL. To improve the sig-to-noise ratio, install a 390 Kohm resistor on the emitter of Q12 (active filter) as described below.

Required parts:

390 Kohm chip resistor (RK73FB2A394J)

1. Disconnect the battery and antenna.
2. Remove the 7 screws from the back panel of the transceiver (figure 1).
3. Lift the front panel from the transceiver and lay it to the right side.
4. Disconnect the 2 flex cables and remove the 3 screws from the IF unit (figure 2).
5. Pull the top panel off and then remove the IF unit.
6. Remove the 8 screws from the RF unit and unplug connector CN2 (figure 3). Remove the RF unit from the back cover.
7. Locate capacitor C82 on the foil side of the RF unit (figure 4).
8. Solder the 390 Kohm chip resistor directly on top of C82.
9. Assemble the transceiver by reversing steps 1 - 6.

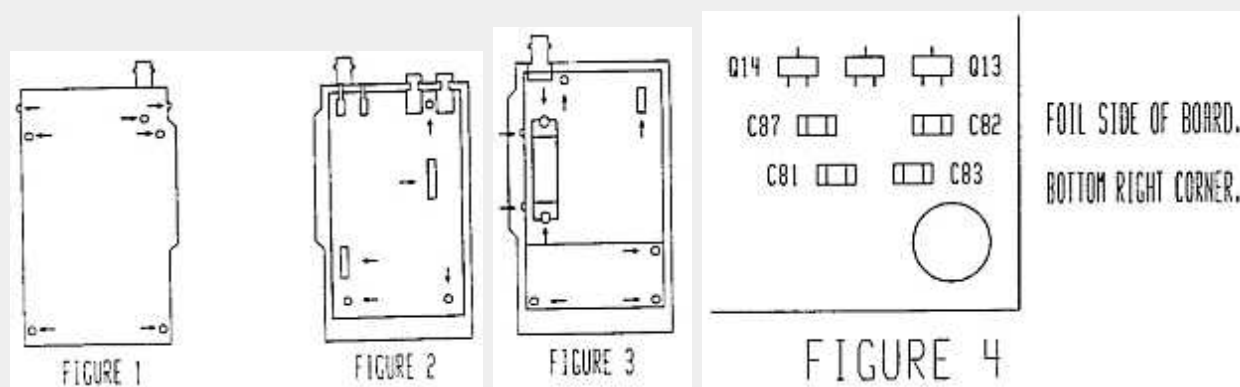

This modification may be covered under warranty.
Time required for this modification is ½ hour or less.

This modification is read 518 times.

[top of page](#)

21-04-2000

(TH-205) TH-205/215/315/415 PTT knob installation procedure

Author: Kenwood Communication, inc.

Service Bulletin no. 987 (11-6-1991)

The original plastic knob (K29-3054-15) has been replaced with a rubber knob (K29-3054-35). The PTT mounting guide on the front panel must be removed to allow the new knob to be installed. The following procedure will explain the installation procedure.

1. Disconnect the battery pack and antenna.
2. Remove the four screws from the back panel.
3. Carefully lift the front panel up and lay it into the right side of the body of the transceiver.
4. Disconnect the front panel from the body of the transceiver.
5. The plastic PTT knob is held in place with three tabs. Press in the bottom tab and then push the knob out of the front panel.
6. Push in the guide to crease it's two legs where they join the front panel.
7. Wiggle the guide back and forth until it breaks off the front panel. Discard the guide and plastic knob.

8. Install the rubber knob on the front panel. The side with the square tab goes toward the bottom of the front panel.

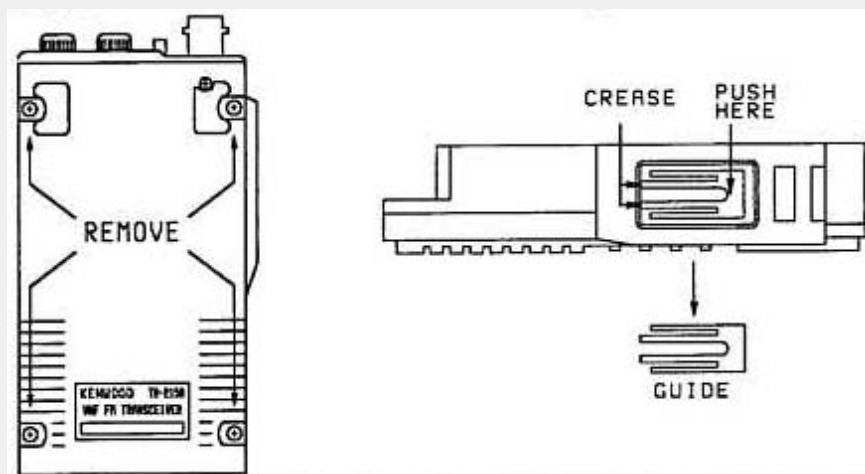

This modification is read 511 times.

[top of page](#)

19-07-1998

(TH-215) TH-205/215 Protection Fuse Replacement

Author: Trio-Kenwood Communication, inc.

Service Bulletin no. 920 (22-7-1987)

When a plug other than the PG-2V or PG-3C is inserted into the DC IN jack, the ground side of the jack may not disconnect. This may cause the external DC power to be supplied directly to the internal battery which results in overheating the battery and blowing the fuse. To protect the battery, replace the fuse with a protection diode, part number ERB83-004.

Note models with serial numbers greater than 801XXXX already incorporate this diode as D16.

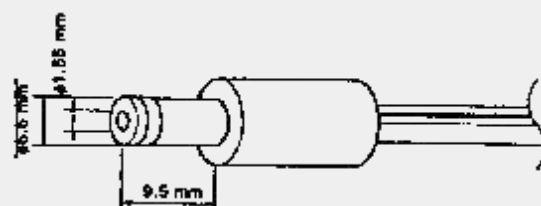

DC Plug specifications

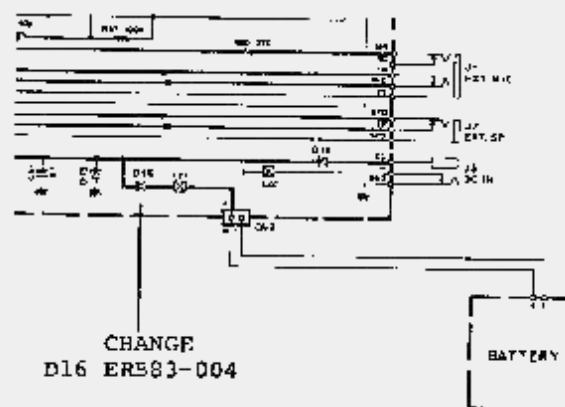

This modification may be performed under warranty.
Time required for this change is 1/2 hour or less.

This modification is read 613 times.

[top of page](#)

19-07-1998

(TH-215) TH-215A to TNC

The hook-up of a th-215a to my pac-comm tiny 2 tnc was very easy. There are no components involved in the connection. All you need are two phone plugs: 1 sub mini, and 1 stereo(3 conductor) mini.

Both available from radio shack,two to a pack.

if you have a kenwood speaker mike, then the instruction sheet will contain a drawing showing the basic connecting lines. if not, heres how its done:

The sub-mini is the speaker plug. The center pin goes to the speaker pin on the 5 pin din on the tnc, the shaft is the ground.

On the mini stereo plug, you dont use the center pin, just the two shaft connections. the short shaft goes to mike, the long shaft is the push to talk.....thats it, four wires to the connector that goes to the tnc plug, and youre in business!!

One very very important thing-----always make sure that all battery save functions on the handy talkie are off. if it isnt, a slight delay in receiving will cause retrys from the station sending to you, and will delay packet reception at your end. please make careful note of this. Any questions, reply to K2JOV, HARRY, at N2ELC-4 BBS in n.j.....good luck!!

This modification is read 610 times.

[top of page](#)

19-07-1998

(TH-215) KENWOOD TH-215A out-of-band mod

1. Remove two screws from belt clip
2. Remove 4 screws from back of radio
3. Slide front assembly off
4. Locate set of 4 jumpers:

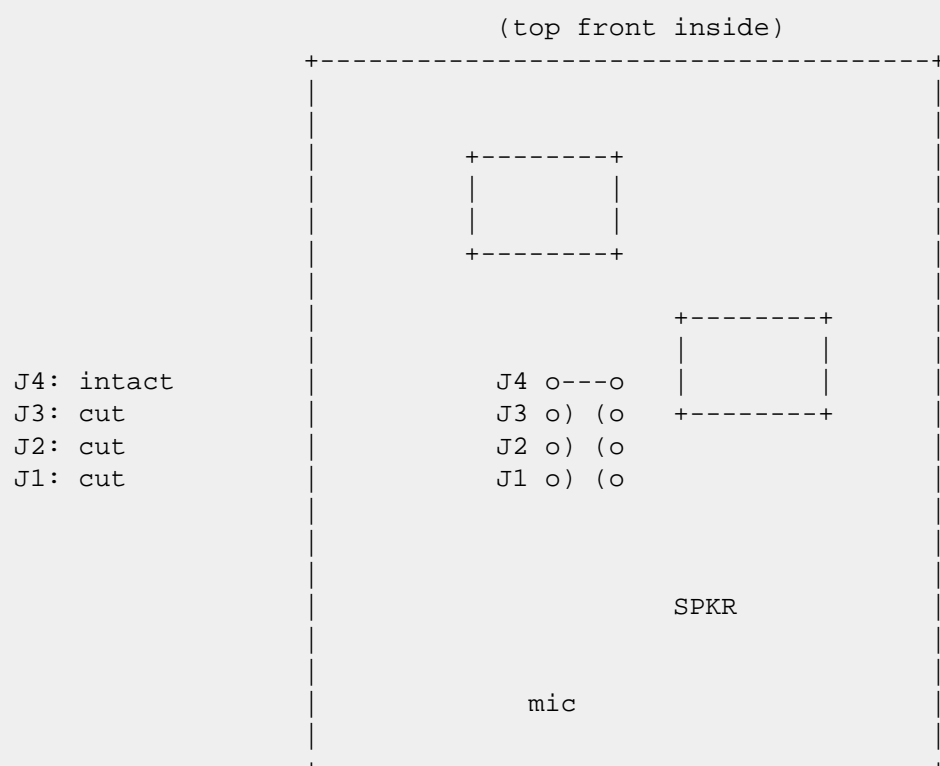

5. Reassemble radio.
6. Reset microprocessor: Turn radio on while simultaneously pressing both `_F_` key and `_ENTER_` key.
<

This modification is read 752 times.

[top of page](#)

19-07-1998

(TH-215) A TH215 no audio fix

Newsgroups: rec.ham-radio

Subject: Re: Kenwood TH-215A no audio problem

Organization: Hewlett-Packard Co., Corvallis, OR, USA

PROBLEM:

>In a sample population of about 60 amateurs in this town, three of us
>own Kenwood TH-215A HT's, all purchased separately at different times
>from different sources....

>ALL THREE have developed an audio problem in the last eight months:

>the audio (both from the microphone and from the keypad) simply
 >disappears at unpredictable intervals. And all three can be "fixed"
 >by WHACKING the HT with the palm of one's hand--until it happens again.

A POSSIBLE FIX:

You guys may be in luck, since I fixed mine -- I have the service manual and decided to jump in (I had upgraded the software and you have to pull the unit completely open to do it --). Anyway, I was using the rig one day and the next -- no audio -- just a slight noise that appeared to be white noise from the final audio buffer. When plugging in the speaker mike -- same problem. Touch the TTPAD and get your ears blown away -- I think beep also worked. Kenwood had no knowledge of previous problems.

I had to rig-up a jumper ribbon cable so I could lay the rig out for testing and immediately checked the input audio to the volume control.

No problem -- but there was nothing coming out the other side. I jumpered the pot (i.e. simulate pot max volume) and my ears were hurting. Upon removal of the pot I found a crack on the ALPS pc board that has the leads mounted to it. Apparently, I must have hit the volume control pot the previous day and cracked the pot trace (again this trace was part of the pot not the rig pcb). I had noticed when I disassembled the unit that there was no nut on the pot to hold it in place (none on the squelch either). The volume pot is right at the edge of the unit and is the most likely knob to get hit.

When parts arrived, it came with a nut so I installed it to help prevent this problem in the future -- no problems since.

I think the switched volume pot cost \$4.95 + \$3.00 shipping.

I also picked up a set of backcase screws -- very small heads but very long screws to replace my old ones -\$.05 - Make sure you have a "good" screwdriver that really fits.)

All these problems sound like the same thing. I have never had any problems with my rig, and I bought one of the first ones out. (Hence, the software update to give me the ability to lock out memory channels during scan.)

Date: 04-01-2002 **User comment** **From:** [Brent Corbin, wy6s](#)
Subject: Audio problems on all th-x15's?

Wow - I bought two th-315's, and have precisely this problem with one of them. More than likely the problem afflicts the entire th-x15 series. Replacing the volume pot (in my case, to repair earthquake damage) did not fix the problem on the transmit audio - it did fix similar behavior in the receive audio caused by a broken pot trace.

This modification is read 612 times.

[top of page](#)

19-07-1998

(TH-215) TH-215 jumper modification

The Th215 transceiver can be modified by setting jumpers in the following positions:

J1	J2	J3	J4	RX	TX	step	DTMF	TONE
1	1	1	1	144-146Mhz	<==	20k	YES	38 tone
1	1	1	0	141-163Mhz	144-146	5k	YES	38 tone
0	1	1	1	144-146Mhz	<==	5k	NO	TONE1750hz
1	0	1	1	144-146Mhz	<==	5k	NO	1750 hz
0	1	1	0	144-146Mhz	<==	12.5k	NO	TONE/1750hz
1	0	1	0	144-146Mhz	<==	12.5k	NO	1750 hz
0	0	1	1	144-148Mhz	<==	5k	YES	38 tone
1	1	0	1	141-163Mhz	144-148	5k	YES	38 tone
0	1	0	1	141-163Mhz	141-151	5k	YES	38 tone
0	0	0	1	141-163Mhz	<==	5k	YES	38 tone
0	0	1	0	134-148Mhz	<==	5k	YES	38 tone
1	0	0	1	154-174Mhz	<==	5k	YES	38 tone

0 = No jumper

1 = jumpered

16-04-2000

(TH-215) TH-205/215/415 Volume/squelch control improvement

Author: Trio-Kenwood Communication, inc.

Service Bulletin no. 944 (28-10-1988)

The transceivers mentioned above can be mechanically improved by adding a bracket assembly to the volume and squelch controls. The bracket assembly is being used in current production and is available for older units from the Kenwood Parts Department.

Bracket Ass'y (W05-0235-00)

1. Disconnect the battery pack and antenna.
2. Remove the 7 screws from the panel of the transceiver (Figure 1).
3. Lift the front panel from the transceiver and lay it to the right side.
4. Disconnect the 2 flex cables and remove the 3 screws from the IF unit (Figure 2).
5. Pull the top panel off and then remove the IF unit.
6. Remove the knobs and black cloth from the volume and squelch controls.
7. Inspect the controls to insure they are mounted flush to the board. If they are not flush, completely desolder and resolder the controls.
8. Insert the bracket over the controls and tighten the nuts (tighten the nut on the volume control first). See figure 3 for the bracket assembly view.
9. Assemble the transceiver by reversing steps 1 - 6.

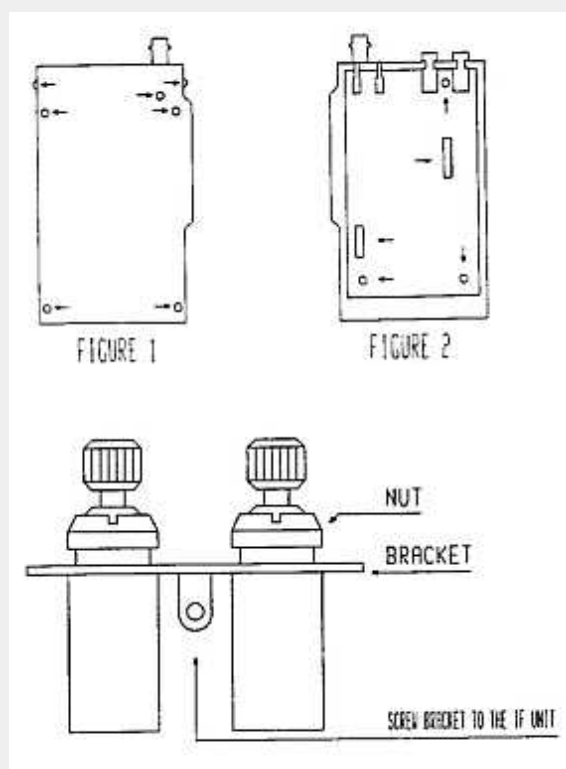

This modification may be covered under warranty.
Time required for this modification is ½ hour or less.

16-04-2000

(TH-215) TH-215/415 TX signal-To-Noise ratio improvements

Author: Trio-Kenwood Communication, inc.

Service Bulletin no. 946 (28-10-1988)

The TH-215/415 transmit signal-to-noise ratio is typically 30 dB. This ratio is more than sufficient for routine operations. For those users who would like to obtain additional performance, the following modification will provide an improvement of 5 to 8 dB.

Required parts:

47 ohm 1/10 watt chip resistor	(RK73FB2A470J)
220 ohm 1/10 watt carbon resistor	(RD14BB2B221J)
22 μ F 6.3V Electrolytic capacitor	(CE04CW0J220M)
1 μ F 50V Electrolytic capacitor	(C90-1248-05)

1. Disconnect the battery and antenna.
2. Remove the 7 screws from the back panel of the transceiver (figure 1).
3. Lift the front panel from the transceiver and lay it to the right side.
4. Disconnect the 2 flex cables and remove the 3 screws from the IF unit (figure 2).
5. Pull the top panel off and then remove the IF unit.
6. Remove the 8 screws from the RF unit and unplug connector CN2 (figure 3). Remove the RF unit from the back cover.
7. Locate R50 (TH-215) or R60 TH-415) on the foil side of the RF unit (figure 4). Replace the resistor with a 47 ohm chip resistor.
8. On the component side of the IF unit, add a 1 μ F capacitor as shown in figure 5.
9. Also on the component side, cut one foil, add a 220 ohm resistor, and add a 22 μ F capacitor as shown in figure 6.
10. Assemble the transceiver by reversing steps 1 - 6.

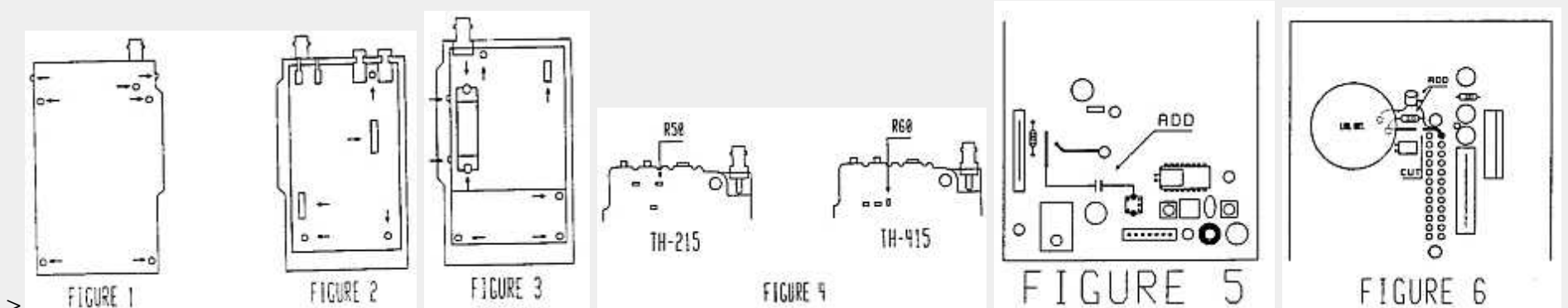

This is an optional change that may not be covered under warranty.
Time required for this modification is 1 hour or less.

This modification is read 596 times.

[top of page](#)

21-04-2000

(TH-215) TH-205/215/315/415 PTT knob installation procedure

Author: Kenwood Communication, inc.

Service Bulletin no. 987 (11-6-1991)

The original plastic knob (K29-3054-15) has been replaced with a rubber knob (K29-3054-35). The PTT mounting guide on the front panel must be removed to allow the new knob to be installed. The following procedure will explain the installation procedure.

1. Disconnect the battery pack and antenna.
2. Remove the four screws from the back panel.
3. Carefully lift the front panel up and lay it into the right side of the body of the transceiver.
4. Disconnect the front panel from the body of the transceiver.

5. The plastic PTT knob is held in place with three tabs. Press in the bottom tab and then push the knob out of the front panel.
6. Push in the guide to crease it's two legs where they join the front panel.
7. Wiggle the guide back and forth until it breaks off the front panel. Discard the guide and plastic knob.
8. Install the rubber knob on the front panel. The side with the square tab goes toward the bottom of the front panel.

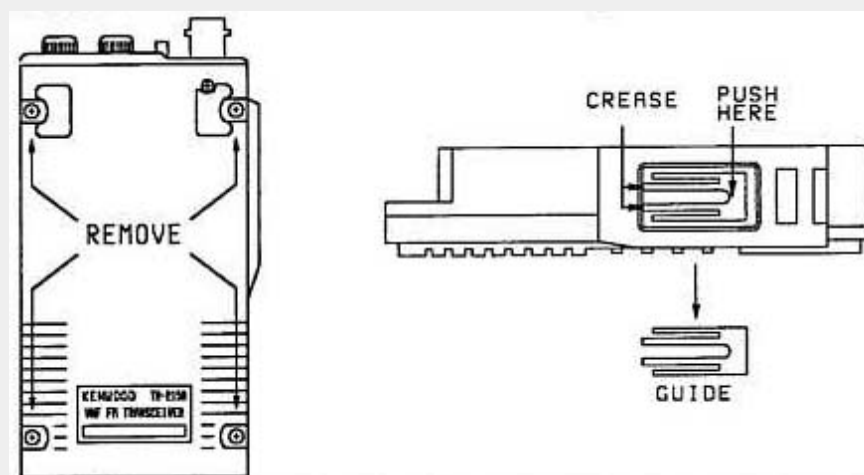

This modification is read 579 times.

[top of page](#)

16-12-2001

(TH-215) TH-215A handheld transceiver 12.5KHz modification

Author: Brian G8OSN - brian.reay@engineer.com. MODIFICATION.NET

I recently inherited a Kenwood TH215 which I decided to press into service but I really wanted the convenience of 12.5KHz channel spacing - the original offering only 5,10,15,20 or 25Khz spacing.

A trawl of the Web turned up various erroneous or incomplete data - none of which quite did the job. However, this data (from various sources), combined with some help from another amateur, and a bit of 'head scratching' solved the problem.

The modification is in three parts:

1. Modification of the display and entry logic by use of the 'customer jumpers' J1 to J4. (this data is generally freely available but is only part of the storey!)
2. Change the reference xtal from 12.8MHz to 16 MHz.
3. Adjust the deviation to suit 12.5kHz spacing.

Note: After this modification the radio will work between 144 & 145.9875MHz, with 1750 Hz tone and +/- 600 repeater shift. If anyone cracks the same mod with CTCSS I'd like to know how it is done, please.

Setting the Customer Jumpers

1. Battery, rubber duck and belt clip (2 screws)
2. Remove 4 screws from back of radio
3. Gently pull front assembly (keyboard & display) off and fold to side.
4. You will find the 'customer jumpers' on the rear of the keyboard pcb. It may be necessary to GENTLY peel back the cloth cover over the main uP.
5. Set jumpers to: J1 cut, J2 jumpered, J3 jumpered, J4 cut.

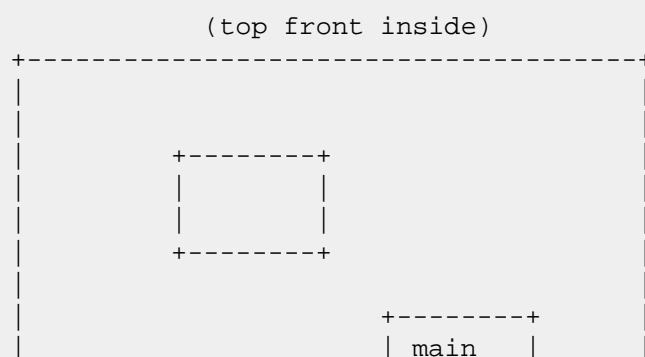

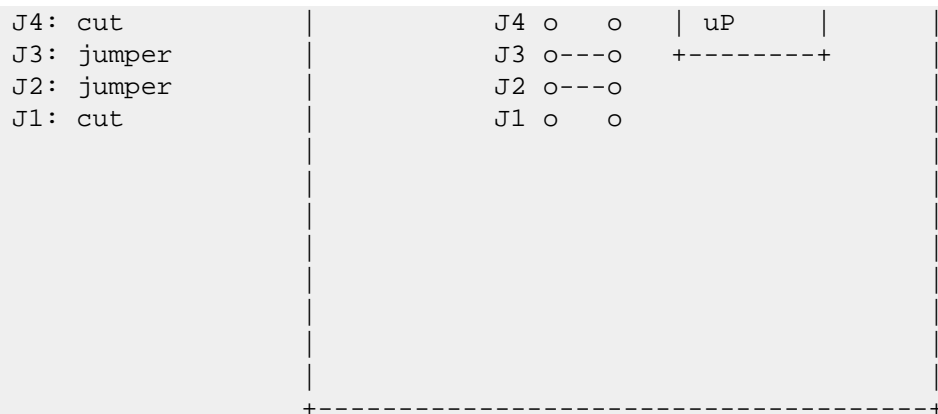

6. Replace cloth cover on uP (if disturbed)- it should just press back.

Changing the Reference Xtal

1. Remove volume and squelch knobs and rubber connector cover
2. Remove 3 small screws, 2 from sides holding top panel and 1 from back, near belt clip holes. Remove top panel.
3. Remove 3 screws securing IF PCB (1 between vol and squelch pots, 2 at bottem edge of PCB.)
4. GENTLY remove IF PCB and put to one side, still connected to the front panel assembly.
5. Remove screws securing remaining (RF) PCB- including those on the PA heatsink.
6. Locate the reference Xtal near the corner of the RF PCB, diagonally oppersite the antenna BNC.
7. Remove reference Xtal (12.8MHz) and replace with 16MHz Xtal (wire ended) ENSURING you include insulating sleeve from the original Xtal. Secure new Xtal with small piece of double sided tape.
8. Replace RF PCB, checking mounting screws for PA heatsink.
9. If you have a suitable extension cable for the RF/IF PCB link use it. Connect a dummy load and power and check and adjust Tx frequency using small trimmer by the reference Xtal. Aim to be within 200Hz or so at 145Hz.
10. If you don't have a suitable cable, replace IF PCB (no need to screw down but check alignment), connect dummy load and power and check Tx frequency. If it is off frequency, remove power, IF board, tweak xtal trimmer, reassemble and try again. Two or three goes should get you on frequency.
11. Replace IF PCB mounnting screws, top cover, small screws, knobs etc. but not the front case assembly.
12. If you have a deviation meter, adjust VR7 (2/3 way down IF PCB on left) for 3Khz peak dev.
13. Without a deviation meter, I'm afraid it is trial and error with either a local colleague or the local repeater at a quiet time.
14. Complete reassembly of the radio.

Note: The above modification has been successfully completed by me on my th215. i make no other claims and accept no responsibility for your success or failure.

The above modification is based on a combination of information from various sources and some original investigation by me. all sources acknowledged.

73
 Brian
 G8OSN
 11/9/2000

This modification is read 518 times.

[top of page](#)

19-07-1998

(TH-22) TH-22E and CLONE

After expanding of TH-22E by cutting the wire, I have gained much wider band and several options. "CLONE" is the one of them. You can run it by pressing the REV button when turning on the handie. The text "CLONE" will appear on the display and you can start cloning by pressing the PTT.

This modification is read 1642 times.

[top of page](#)

19-07-1998

(TH-22) TH-22AT Beyond Mars Modification

This Mod is TH-22AT Beyond Mars Modification Dated November 12, 1993 from Kenwood.

1. Turn off the power.
2. Remove the battery pack.
3. Remove the two long screws from the rear or the case.
4. Remove the two knobs from the top of the unit.
5. Remove the rubber top panel.
6. Squeeze the bottom of the front panel together and GENTLY separate the two case halves. Use caution so that you do not damage the thin ribbon cable connecting the front panel to the main unit.
7. Remove diode D208. Located on the circuit board behind the front panel. See ascii artwork below.
8. Place the diode you just removed (D208) in the location shown for D212 and solder in place. Observe proper polarity. The diode should face the same direction as diode D210 and D211.
9. Reverse steps 1-6 to reassemble.
10. Reset the microprocessor.

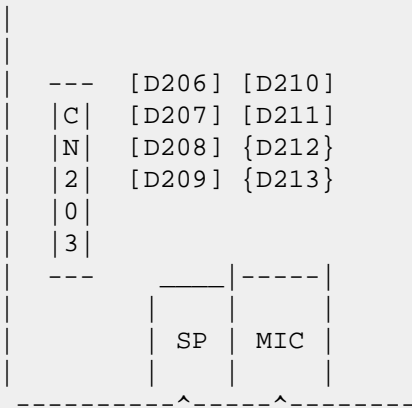

This modification requires soldering equipment rated for CMOS type circuits. It also requires familiarity with surface mount soldering techniques.

Date: 19-01-2002

User comment

From: [Lanfah](#)

Subject: What does it do?

What does the modification do and how does it improve it?

This modification is read 1884 times.

[top of page](#)

19-07-1998

(TH-22) Expanding TH-22 to 136-174 MHz

Hello OM's

the only modification I know and have tested with my TH22E is expanding it to 136-174Mhz range and turning into US mode. Unfortunately I don't think it is possible without opening the case. Here's how to do it:

1. Remove battery pack and reassemble the case. Open the case carefully as there's special tape-connector connecting both halves.
2. Find the little cables on the top-right corner of the silverplate (on the LCD display part).
3. One of the cables is marked as "CH". Cutting this will turn your th22e into channel-only TRX (number of channels will correspond to the memory settings). Better don't cut this - you can set the same from the menu.
4. Next cable (to the left of that "CH") keeps the range reduction. Cutting this will expand your portable and turn into US-mode.
5. Close the case, replace screws, etc. and reset your TH22E (by pressing F-key when turning on).

here comes the schema of this:

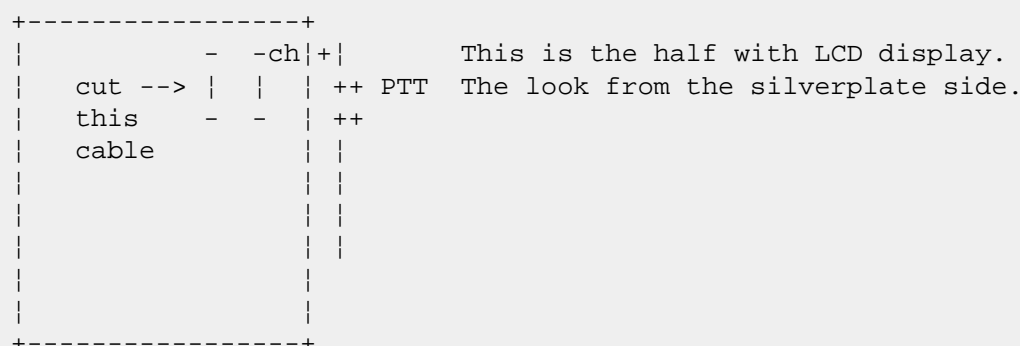

In US-mode you can also use the CLONE-MODE. Just keep pressed the the REV/SHIFT key when turning on. Press PTT to start cloning

to the other TH22E.

This modification is read 2141 times.

[top of page](#)

19-07-1998

(TH-22) KENWOOD TH-22E xpansion...WARNING

Hi there.

For those of you wondering how to expand the freq. coverage of your TH22E, this is how you do it:

Remove battery and unscrew the two screws holding the front and back of the rig together. Carefully squeeze the sides of the bottom of the rig together so that the back cover comes unclipped from the front and ease forward to clear the LEDs on top (you will need to peel back the rubber top).

Inside, you will see two green wires marked W201 and W202. Cutting W202 will expand the TH22E from 137MHz to 174MHz on receive AND TRANSMIT.

DO NOT CUT W201! as this will cause the rig only to operate on the memory channel setting and **THIS CANNOT BE REVERSED** (Meaning that your TH22 will have to be returned to the manufacturer).

Replace backplate and battery.

I hope this is of help to some of you. The W202 mod has been tried by the supplier and the set appears to be working very well. There are some diodes nearby which I assume can be altered to give different RX/TX settings. Any suggestions.

This modification is read 1930 times.

[top of page](#)

23-04-2000

(TH-22) TH-22/42A/E Memory loss improvement

Author: Kenwood Communication, inc.

Service Bulletin no. 1057 (28 March 1994)

Symptom:

Memory loss can occasionally occur if the following procedure is observed:

1. Program the memory with any desired information.
2. Allow the battery pack with to drain down over an extended period of time without turning off the transceiver. For example turn the volume control up and squelch off. After approximately 8 hours the battery voltage will drop to approximately 3 - 4 Vdc.
3. Turn off the POWER SW.
4. Connect a DC voltage supply or a fully charged battery pack.
5. Turn on the POWER SW.
6. Memory will have been lost.

Corrective Action:

Replace microprocessor IC206 with the improved part listed below. This part incorporates an software improvement to correct this symptom.

Parts required:

Qty	Description	Old part No.	New Part No.	Circuit Description
1	Microprocessor	HD404629B17TF	HD404629B49TF	IC206

Time required for this modification is 60 minutes or less.

This modification is read 1524 times.

[top of page](#)

19-07-1998

(TH-225) Kenwood TH225A modifications

The TH-251A is very similar to the TH-225A. The following TH-215A mod has been tested on the TH-225A and seems to work, thanks Steve(W9OMX).

All the standard disclaimers apply, use at your own risk, etc.

73's John - WA8ZGO - jkesling@cup.portal.com

Date: 2 May 88 15:22:00 GMT

Posted by: silver!commgrp@iuvax.cs.indiana.edu

Subject: Kenwood TH-215A modification

KENWOOD TH-215A handheld transceiver out-of-band modification:

1. Remove two screws from belt clip
2. Remove 4 screws from back of radio
3. Slide front assembly off
4. Locate set of 4 jumpers:

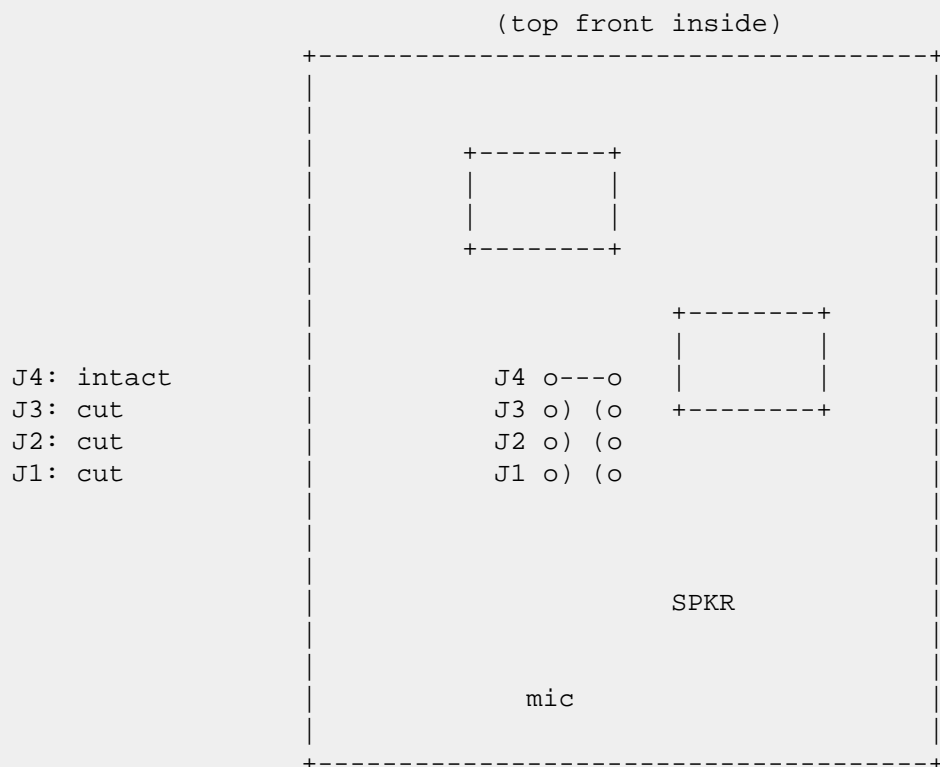

5. Reassemble radio.
6. Reset microprocessor: Turn radio on while simultaneously pressing both _F_ key and _ENTER_ key.

This modification is read 407 times.

[top of page](#)

19-07-1998

(TH-25) TH-25AT MARS/CAP modification

The following modifications will allow the TH-25AT to transmit from 141.000 to 162.995 MHz. Specifications are guaranteed for the Amateur band only. The transceiver may require realignment of the PLL circuits.

1. Disconnect battery pack and antenna.
2. Remove the volume, squelch and tuning control knobs by pulling them straight up from the top panel.
3. Using a 7mm spanner wrench, remove the nut from the volume control and the nut from the tuning control.
4. Remove one screw from the back of the radio, by the PTT switch.
5. Remove one screw near the speaker jack.
6. Remove two screws from the battery terminal plate:

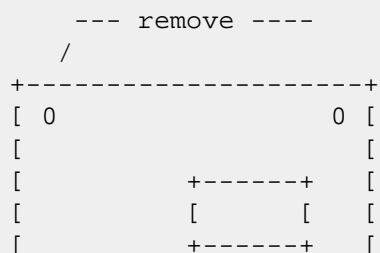

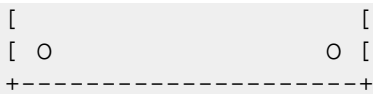

7. Carefully pull the front panel up from the transceiver (do not break the wires connected between the front panel and the body of the transceiver). Lay the front panel to the side of the transceiver (keep track of the PTT and F.LOCK covers if they come off).
8. Gently lift the top panel from the transceiver by pulling it forward and then up (the O-ring on the BNC connector will produce some tension).
9. Rotate the top panel toward the front of the radio to expose the 3/4 x 3/4" board.
10. Using a 45 watt (or less) soldering iron that has an isolated or grounded tip, unsolder and remove chip resistors R19, R20 and R21 from the control unit (X53-3080-02).
11. Carefully reassemble the transceiver by reversing steps 1-9. Pull the BNC connector O-ring up a little before installing the top panel.
12. Reset the microprocessor by following the procedure in the instruction manual (p. 16) called CLEARING ALL MEMORY.

Disclaimers:

The source of this information is unknown and not personally verified. It is illegal to transmit outside the ham bands with this equipment.

Frank W9MKV reid@gold.bacs.indiana.edu

This modification is read 695 times.

[top of page](#)

19-07-1998

(TH-25) KENWOOD TH-25/45 out of banad modifications

Here are some mods for the TH-25AT and the TH-45AT. Please note that I do not encourage transmitting on a frequency for which you do not have a license, nor do I encourage transmitting on a non-amateur frequency without FCC type accepted equipment (in the United States).

First let me recommend that you buy the service manuals for these radios. The service manual is not expensive (about \$15 I think) and it will greatly help you in performing these modifications.

Look at the schematic for your radio. In the lower left hand corner is an IC labeled IC2. This is an ASIC microprocessor. At the lower right hand corner of this uP are several diodes and pull-up/pull-down resistors. They are D4, D3, R19, R18, R28, R20, R21, R22, R25, R26, and a couple of resistors that are not even on the schematic that attach to B2 (pin 51 on IC2) and B3 (pin 50 on IC2). The TH-45AT schematic shows R23 on the ASIC uP pin B2.

The schematic for the TH-25AT shows:

			R18-R21	R25	R26,27	R28	R36
TH-25A	M,M2	-12	O	X	X	X	X
TH-25A	M3,M4,X	-23	O	X	X	O	X
TH-25AT	K	-11	O	O	X	X	X
TH-25AT	M,M2	-12	O	X	X	X	X
TH-25E	T	-52	X	X	O	O	O
TH-25E	W	-62	X	O	O	O	O

And the schematic for the TH-45AT shows:

			R19-R21	R22	R23	R25	R26,27	R28	R36
TH-45A	M1,M2,X	-21	O	O	O	X	X	O	X
TH-45A	M3,M4	-22	O	X	O	X	X	X	X
TH-45AT	K	-10	O	X	O	X	X	O	X
TH-45AT	M1,M2	-21	O	O	O	X	X	O	X
TH-45AT	M3,M4	-22	O	X	O	X	X	X	X
TH-45E	T	-51	X	O	X	X	O	X	O
TH-45E	W	-61	X	O	X	O	O	O	O

where O means USED, and X means NOT USED.

On the TH-25AT:

(All frequencies given in MHz.)

R22 in

R28 out

This is how the radio is delivered in the USA. TX 144-1, 141-163

(I think).

R22 out

R28 in

The radio tunes from 142-151. This may be the modification given to US MARS members. I don't remember where the unit will transmit. It may or may not transmit outside the range from 144-148.

R22 in
R28 in
The radio tunes only from 144-148.

R22 out
R28 out
Frequencies may be selected from 100-200 MHz (on the display only - your PLL will not lock up in this entire range). In addition, TX is possible where your PLL locks up.

R25 out
Removing R25 disables automatic offset selection.

R23 and R24 are used for selecting the step size for tuning. I can't remember which positions are for which step sizes, and alas I didn't write down what I found. If you want to play with this, go ahead.

On the TH-45AT:
(All frequencies are given in MHz.)

R18 in
R28 in
This is how the radio is delivered in the USA. The radio covers 438-450 MHz.

R18 in
R20 out
The radio is prohibited from tuning outside 440-450 MHz.

R18 out
R28 in
The radio will only tune from 215-230 MHz. Note that the PLL would not lock up! (What did you expect?) Could it be possible that Kenwood originally planned a 220 version of this radio, but then scrapped their plans?

R18 out
R28 out
The radio will tune from 200-500 MHz (on the display only - your PLL will not lock up over this entire range). Transmitting is possible anywhere your PLL will lock up.

Some of the above codes are:

K USA
T England
X Australia
M Other Areas

These components are found on the flexible circuit board under the display. To get to them, take the radio apart. Some unsoldering of obvious grounding wires may be necessary. You will see where the flexible circuit board plugs into a socket on the main circuit board. Before unplugging it, make sure you know what's in the memories, because they will be lost. Unplug the flexible circuit board and unfold it so that the components are accesable. One of the fold-out parts of the flexible board will look something like this:

```
+-----+
! R  R R D3 R R !
! 2  2 2   7 2 !
! 5  3 2   1 !
!
! R  O      O R20!           The O's are solder pads.
! 2  O      O R19!
! 6  O      O R18!
!   O      O R28!
!
!           R !
!           D4 6 !
!           +-----+
!           !
!           !
```

The fold out board is actually square, but with only characters for graphics, I couldn't draw it that way.

On both radios, R36 is for the European tone burst to "whistle up" repeaters.

On both radios, D4 is for selecting the type of display. With D4 in, the display is normal. With D4 removed, the display is a channel display.

D3 is for selecting VHF or UHF. With D4 in, the radio thinks its a VHF radio. With D4 removed, the radio thinks its a UHF radio. Don't change this on your radio.

I have found a quick and easy way to retune your PLL (in the TH45-AT) with a minimum of test equipment. All you need is a scope and a small tuning tool. First, take off the battery pack holder plate. Then, remove the silvery sticker covering the tuning pot access holes. If the radio is positioned on its back, with the top folded over so that the touch tone pad is also facing down, the test point you want (TP1) is on the bottom half of the radio, near the center (left to right), and close to the battery; the tuning pot you want (TC1) is

on the bottom, and closest to the PTT switch. Under no circumstances change the tuning of TC51. This is used to calibrate the output of the radio with the display the radio is giving; you don't want to mess with it. Once again, the Service Manual makes it very clear where these points are, if you are having trouble with my descriptions. On with retuning the PLL. With the radio on, and receiving, monitor the voltage and the waveform on test point TC1.

Tune the radio DOWNWARDS in frequency until the PLL unlocks. Note that the radio will beep when this happens, and the waveform on TP1 will change. Tune the radio about 1 MHz higher so that the PLL locks up again, and note the voltage on the testpoint, TP1. Now, tune the radio to the LOWEST frequency that you want to be able to receive. Adjust TC1 until the voltage on the test point TP1 is the same as what was noted earlier. Button the radio back up, and you're done. You will not be able to tune the PLL to any range you want.

There are limits. On my radio, I have been able to retune the radio so that I can receive from 439.2-468.6 MHz with a set of batteries fresh out of the charger. The tuning range will probably diminish as the battery voltage decreases. I have not retuned the PLL on my 2m HT, but I'd imagine the same technique will prove fruitful.

I may have some more information on these radios someplace. If I can find it, I will add to this posting, and post it again with the updated information. Enjoy. Kenneth J. Hendrickson N8DGN

This modification is read 702 times.

[top of page](#)

19-07-1998

(TH-25) TH-25/45AT Automatic Power OFF Function

Author: Trio-Kenwood Communication, inc.

Service Bulletin no. 939 (2-6-1988)

Some users of the TH-25AT/45AT have expressed a desire to defeat the automatic power off function. The following modification will explain how to do this. It should be noted that this modification does not effect the battery saver function.

Required Part:

Diode Kenwood Part #1SS133

1. Disconnect the battery pack and antenna.
2. Remove the Volume, Squelch, and Tuning Control knobs by pulling them straight up from the top panel.
3. Using a 7mm spanner wrench, remove the nut from the volume control and the nut from the tuning control.
4. Remove one screw located by the PTT switch. (Figure 1).
5. Remove one screw located by the speaker jack. (Figure 2).
6. Remove two screws from the battery terminal plate. (Figure 3).
7. Carefully pull the front panel up from the transceiver (do not break the wires connected between the front panel and the body of the transceiver.) Lay the front panel to the side of the transceiver (Keep track of the F.LOCK cover if it comes off.)
8. Remove the PTT cover.
9. Remove one screw from the PTT switch unit. (Figure 4).
10. Gently lift the top panel from the transceiver by pulling it forward and then up (the O ring on the BNC connector will produce some tension.)
11. Carefully unfold the flex Printed Circuit Board (PCB) to expose IC2. (Figure 5).
12. Using a 45 watt (or less) soldering iron that has an isolated or grounded tip, add a diode between pins 23 and 58 of IC2. (Figure 6).
13. Carefully assemble the transceiver by reversing step 1-11. Pull the BNC connector "O" ring up a little before installing the top panel.
14. Reset the microprocessor by following the procedure in the instruction manual (page 16) called CLEARING ALL MEMORY.



FIGURE 1

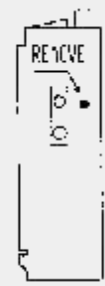

FIGURE 2



FIGURE 3

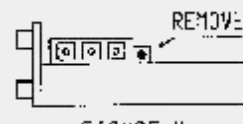

FIGURE 4

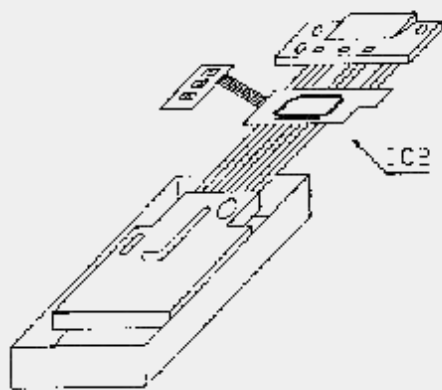

FIGURE 5

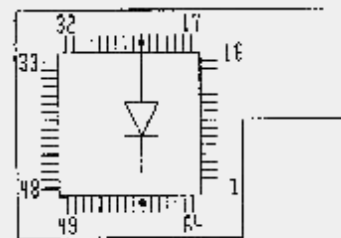

FIGURE 6

This is an optional change that is not covered under warranty.
Time required for this modification is 1 hour or less.

SYSOP NOTES:

Later versions of the TH-25/45AT came with a programmable defeat for the Auto power off function. Do not install this modification if your manual provides a procedure for turning the power off function off! Step 11 tells you to carefully unfold the flexible pc board. It is extremely important that you do not try and bend the board in a direction that is opposite from its current bend. To do so will break the board or the foil traces inside the board!

This modification is read 615 times.

[top of page](#)

19-07-1998

(TH-25) EXT TX ON THE: TH-26AT/TH-45AT/TH-75A HT's

On the three above units a jumper wire controls the TX frequency coverage. By removing the jumper you will extend TX from 142-152Mhz.

By removing a diode you can extend the TX coverage to the limits of the VCO. Both the jumper wire and the diode are located on the "CONTROL UNIT".

On the TH-26AT this is just a bare jumper wire, TH-45AT ???, TH75A it is a green wire labeled W1. Removing or lifting D4 on the TH-75A extends TX from 136-174Mhz and 335-512Mhz.

On the TH-26/TH-46 models this would be 136-174Mhz and 335-512Mhz respectively.

This modification is read 610 times.

[top of page](#)

16-04-2000

(TH-25) TH-25/45 W/TSU-6 Tone alert improvements

Author: Trio-Kenwood Communication, inc.

Service Bulletin no. 932 (11-4-1988)

When using the TH-25/45 in combination with the TSU-6 you may experience erratic operation of the tone alert function. This may be due to an incoming signal that is over-modulated, distorted, or noisy. The following modification will correct this tendency.

Required parts:

22 μ F, 6.3V electrolytic capacitor	part # CE04CW0J220J
56 Kohm, 1/8 watt carbon resistor	part # RD14BB2B563J
Diode	part # 1SS133

1. Remove the TSU-6 from the TH-25/45 (refer to the TH-25/45 instruction manual for details).

2. Cut the blue wire (pin # 4) approximately 5 mm from the connector for the TSU-6.
3. Solder the components to the blue wire and ground as shown in figure 1. Note that the cathode side of the diode goes toward the TSU-6 connector. Use the leg of the VCO shield to ground the negative side of the capacitor.
4. Insulate the components with electrical tape to prevent shorting.
5. Install the TSU-6 in the tH-25/45. Route the components so that the battery terminal plate does not bow when installed.

Figure 1.

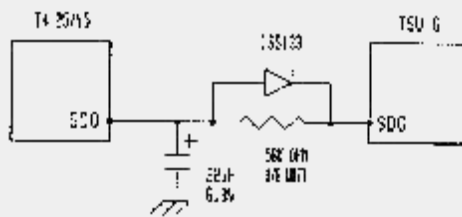

This modification may be covered under warranty.
Time required for this modification is ½ hour or less.

This modification is read 606 times.

[top of page](#)

19-07-1998

(TH-26) EXT TX ON THE: TH-26AT/TH-45AT/TH-75A HT's

On the three above units a jumper wire controls the TX frequency coverage. By removing the jumper you will extend TX from 142-152Mhz.

By removing a diode you can extend the TX coverage to the limits of the VCO. Both the jumper wire and the diode are located on the "CONTROL UNIT".

On the TH-26AT this is just a bare jumper wire, TH-45AT ???, TH75A it is a green wire labeled W1. Removing or lifting D4 on the TH-75A extends TX from 136-174Mhz and 335-512Mhz.

On the TH-26/TH-46 models this would be 136-174Mhz and 335-512Mhz respectively.

This modification is read 801 times.

[top of page](#)

28-08-1999

(TH-26) Expanding frequency range for the TH-26E

Hello OM/YL,

Something on expanding frequency range for Kenwood's TH26E.

To expand frequency range is very simple, you just have to remove the little piece of wire called JP1 on the schematic diagram, it is placed on the left side near the battery pack. This modification makes it possible to transmit and receive over the range of 136.000MHz to 173.995Mhz.

Further expansion is not possible, the PLL doesn't lock anymore. (expanding TX Frequency range outside 144 -146 Mhz is in some countries illegal as we all know). It is also possible to expand RX only. To enable this hardware modification is not nessecary!
Execute the following steps..

1. Put the TH 26E into the VFO Mode
2. Press the Call button,
3. Keep the Call button pressed in and press the MR button also The decimal point on the display will start to blink and when the TH 26E is in the 'beep mode' it will also start to beep at a frequency of 1 Hz.
4. Press the Call button, You will see that a frequency of 245.??? Mhz appears, (the decimals are dependent of the value witch was inserted before starting the programming...)
5. Press the F key and load the 245.??? Mhz into the VFO..
6. Switch your handheld transceiver off
7. Press the REV button while turning the TH 26E on.. The Upper level of frequency is now set to 245.??? Mhz

You must adjust the VFO lowest and highest frequency according to your PLL locking range. My TH 26E PLL locks over a range from 144.000 Mhz to 173.995Mhz. This software modification does not damage the TH26E!

Only reception below 144.000 Mhz is not possible... You can set the TH 26E into normal mode by resetting the VFO.

I'd like to know where my message is received, and if you are succesfull modifying Your TH 26E...

Also I like to know if there are more intresting modifications on this type of transceiver. Please let me know!

Goodluck and '73 From Hengelo The Netherlands JO32KG

Peter (PBOANS @ PI8DAZ.nld.eu).

28-08-1999**(TH-26) Expanding frequency range for the TH-26E****Author:** Mathijs PE1NTP

Schema Kenwood SMC 33 Handmicrofoon met A.B.

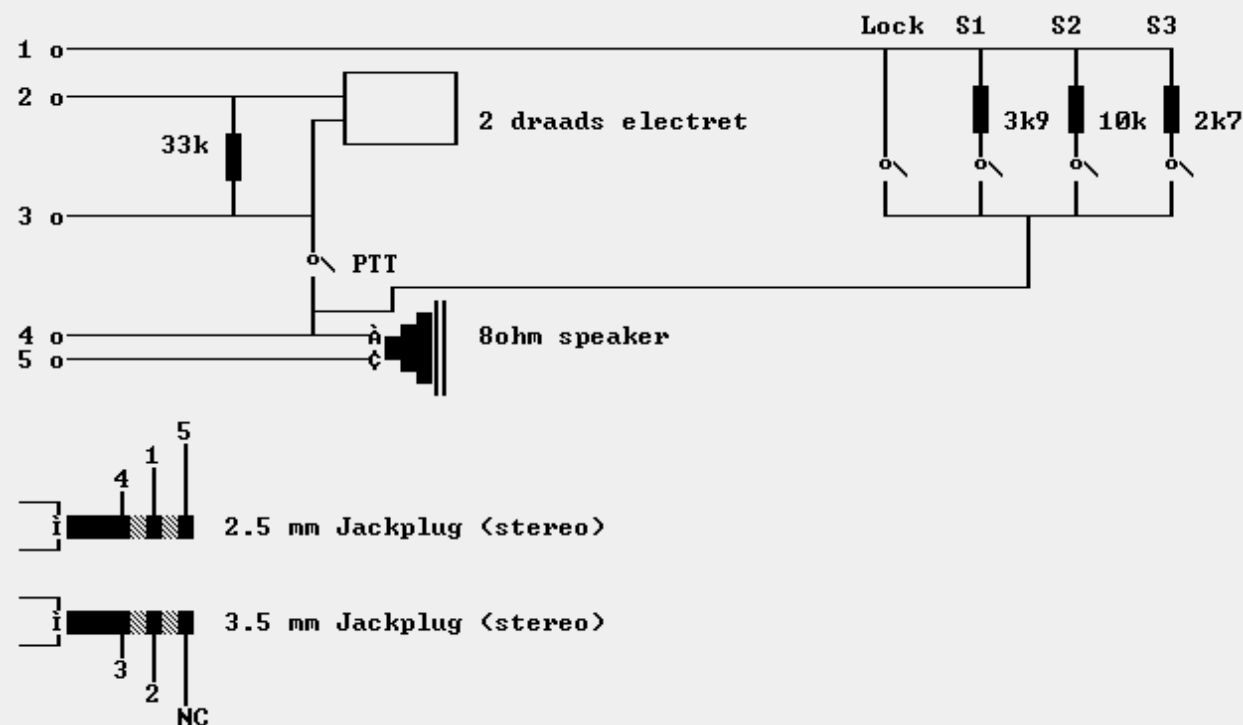

(c) 1992 Mathijs PE1NTP

21-04-2000**(TH-26) TH-26A Internal bridges****Author:** Kenwood Communication, inc.

Service Bulletin no. 976 (8-8-1990)

The TH-26A has two internal bridges. One is at 145.645 MHz and the other is at 147.200 MHz. The first one is caused by the CPU clock and the second one is caused by the PLL reference crystal. The bridge related to the CPU clock can be corrected by changing R78 on the Control board from 3.9 Kohm to 6.8 Kohm and adding a ground to R64. The birdie related to the reference crystal can be corrected by changing L12 on the TX/RX (B/2) board from a 10 μ H inductor to a 1 mH inductor.

Required parts:

RK73GB1J682J	6.8 Kohm chip resistor
L40-1021-14	1 mH inductor

To change R78:

1. Disconnect the battery pack and antenna.
2. Remove the three case screws and four battery plate screws. Figure 1.
3. Lift the front panel from the body of the transceiver.
4. Do not lose the rubber cover for the DC IN jack.
5. Locate R78 on the Control board inside the front panel. Figure 2.
6. Replace R78 with a 6.8 Kohm chip resistor.
7. Install a jumper wire from R64 to the mounting plate behind the PTT switch. Figure 2.

To change L12:

8. Remove the four screws from the TX/RX (A/2) board. Figure 3.
9. Carefully lift the TX/RX (A/2) board up and rotate it and the front panel assembly to the right of the transceiver.
10. Do not lose the rubber cover from the SPEAKER/MIC jack and the plastic piece from the battery release.
11. Remove the two screws from the power module shield and set the screws and shield aside. Figure 4.
12. Remove the four screws from the TX/RX (B/2) board. Figure 4.
13. Remove the three black screws from the back panel that secure the antenna BNC connector.
14. Carefully lift the TX/RX (B/2) board off the back panel.
15. Locate L12 on the TX/RX (B/2) board. Figure 4.
16. Replace L12 with a 1 mH inductor.
17. Assemble the transceiver.

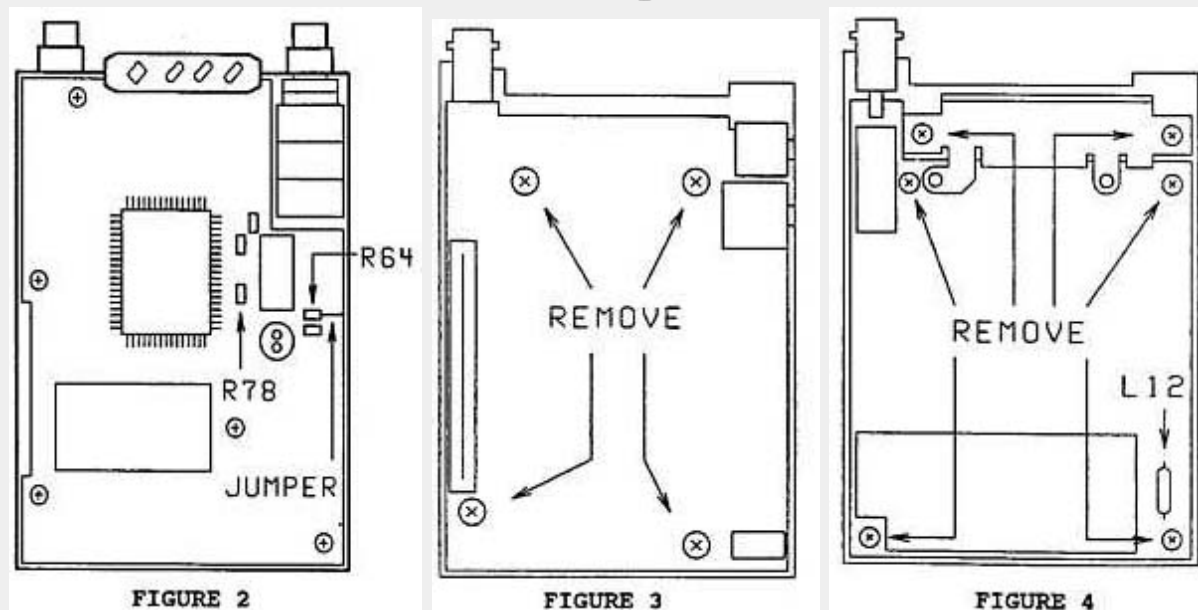
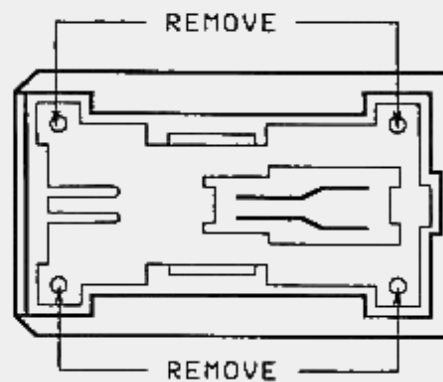
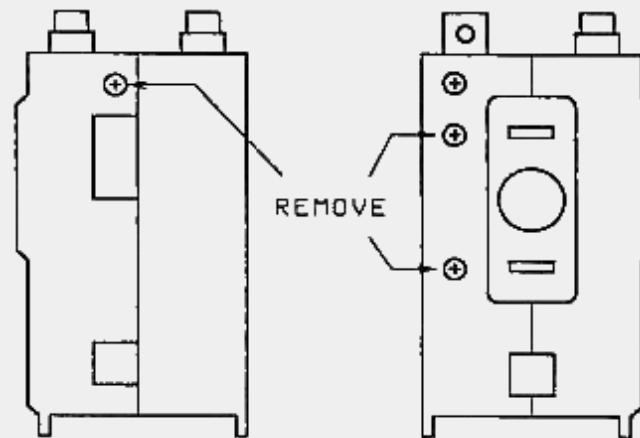

Time required to perform this modification is 1 hour or less.

19-07-1998

(TH-2600) Mod to open TX on the Kenwood TH-2600-a

1. To access the 2600 loosen the two large screws on the sides of the unit with a coin.
2. Remove the 3 very small phillips head screws on the back-side of the unit
3. Remove the battery.
4. In the base of the unit you will see four phillips head screws remove the two that hold down the front of the unit (speaker side)
5. Insert screwdriver into base & twist --you will hear a "pop" as the two halves separate.
6. Carefully lift front & let it turn to the right, as there is a ribbon connection between the front cover & the chassis.
7. In the lower right hand corner of the p.c. board you will see a row of diodes on end (abt 7), snip the top two. (They may already have a solder joint, as these are used in bench test)
8. Note: these are diodes d-32 & d-33 the board you are working on is x55-1380-10 a/2
9. Reverse the process, & there you have it.....

This modification is read 316 times.

[top of page](#)

19-07-1998

(TH-27) Keyboard Mods to access AM detector and change band

A full review of the Kenwood TH27a ran in the March Issue 1991 of CQ

- Press the ENT key once or twice to place HT in VFO mode and in the 2m band
- Depress the F key for 2 secs. (Note flashing F in lower right corner)
- Release F key and press MHz key
- HT will shift to 118.00 MHz and activate the am detector
- Store any freqs from 118-138 into memory
- Hit F key till it flashes
- Hit MHz key
- Your back on 139-170MHz with FM detector

This is a very sophisticated HT and now a great bargain
73-AB4VJ

This modification is read 769 times.

[top of page](#)

21-04-2000

(TH-27) TH-27A/E Low TX power

Author: Kenwood Communication, inc.

Service Bulletin no. 991 (11 May 1992)

We have noticed some variation in the output power provided by Toshiba S-AV22A power modules with a production code of "11". Modules with this production code might exhibit low or no transmitter output power. This procedure will correct this problem.

Parts required:

0.01 μ F axial lead capacitor, (C91-0769-05)

Procedure:

1. Remove chip capacitor C17 and C18 from the TX-RX unit (X57-3640-11).
2. Install the new axial lead capacitor as shown in the accompanying diagram.

Note: Deleting C17 and C18 alone will not correct this symptom. The new C18 will be used to stabilize circuit performance. Deleting C17 alone will not cure the symptom.

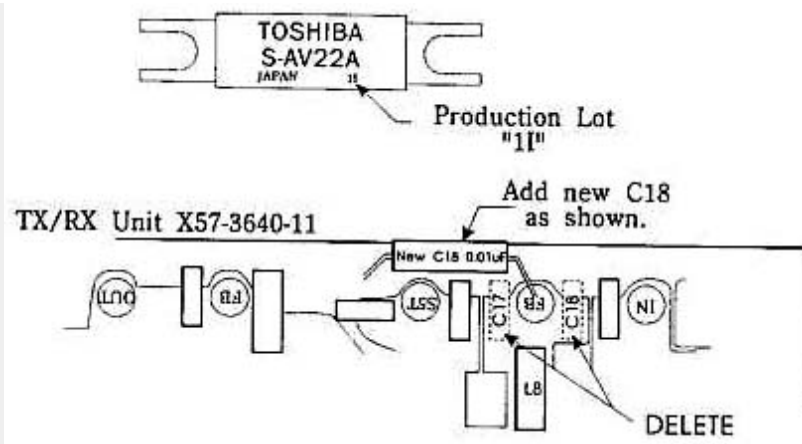

Time required for this modification is 30 minutes or less.

This modification is read 736 times.

[top of page](#)

19-07-1998

(TH-28) Secret function manual of the KENWOOD TH-28e/48e porto

u>TH-28e/48e RX EXPANSION (ON)

Press PTT + VFO, then POWER ON.

New RX ranges TH28e after this modification:

VHF Band 136 - 174 Mhz (FM)

UHF Band 400 - 520 Mhz (FM)

TH48e:

UHF Band 400 - 470 Mhz (FM)

VHF Band 136 - 174 Mhz (FM)

TH28e Air Band Expansion

Press F key for 1 sec. Then press LOW key.

New RX ranges

108 - 118 Mhz (FM)

118 - 136 Mhz (AM)

TH28e 340 - 400 Mhz Expansion

Remove the diode D8 from the control unit. (FM mode only) With Air Band and 340 Mhz expansion, operating band can be changed:

```

----->I AMATEUR I====I 340 Mhz I---->I AIR BAND I_____
I      I_____I      I_____I      I_____I      I
I_____I_____I_____I_____I_____I_____I_____I_____I_____I_____I_____

```

TH48e 340 MHZ & 900 MHZ EXPANSION

Remove the diode D8 from the control unit to cover 340 - 400 Mhz and 800 - 950 Mhz FM mode.

```

----->I AMATEUR I---->I 340 Mhz I---->I 900 Mhz I_____
I      I_____I      I_____I      I_____I      I_____I_____I_____I_____I_____I_____
I_____I_____I_____I_____I_____I_____I_____I_____I_____I_____I_____

```

TH-28e/48e TX EXPANSION

Remove the diode D10 from the control unit.

New TX ranges after this modification:

TH28e:

VHF Band 136.000 - 174.250 Mhz (FM)

TH48e:

UHF Band 400.000 - 470.000 Mhz (FM)

Note:

Manufacturer guarantees TX/RX specification only in amateur band. The above frequency range is for the microprocessor's range so that the receiver sensitivity or TX output power of expanded band may be reduced.

TH-48E TX/RX 432-438 Mhz LIMITED RANGE

Remove the diode D14 from the control unit.

TH28e/48e CROSS BAND REPEATER

Remove the diode D4 then press F key for 1 sec. and press 0 key.

TH-28a/e-48a/e FREQUENCY EXTENSION

Open the case and remove or add the destination chip diode D10, D11, D14 and D15 on the component side of the control unit.
(X53-340X-XX, X53-341X-XX)
The frequency can then be extended as shown in the table 1 an 2 on page 3 and 4. (See the destination chip diode position drawing on the attached sheet.)

Notes:
The frequency display range may differ from the PLL lock range.

	360-Mhz band	Air band
Step	5,10,15,20,12.5,25 Khz	5,10,15,20,12.5,25 Khz
Frequency range	340.000-399.987.5 Mhz	100.000 - 117.975 Mhz
	FM	FM
		118.000 - 135.995 Mhz
		AM
Initial frequency	340.000 Mhz	118.000 Mhz

Initial step value is 12.5 Khz for 360-Mhz band and 25 Khz for Air band.

TH-48a/e BAND EXTENSION

The 360 Mhz band and the 800 Mhz band can be received. To expand the 360-Mhz band and the 800-Mhz band remove chip diode D8 of the control unit as shown in table 2.
You can switch between the UHF amateur band the 360-Mhz band and the 800-Mhz band by pressing the [F] key for 1 sec. and then the [LOW] key.

	360-Mhz band	800-Mhz band
Step	5,10,15,20,12.5,25 Khz	12.5,25 Khz
Frequency range	340.000-399.987.5 Mhz	800.000-949.987.5 Mhz
	FM	FM
Initial frequency	340.000 Mhz	850.000 Mhz

Note:
Program scan is not possible over several bands, but is possible within each band.
Initial step value is 12.5 Khz.

Table 1 TH28a/e

Destination bit	IGuaranteed	TX (Mhz)	RX (Mhz)
IDest	I Min I Max	I Min I Max	I Min I Max
B4 B3 B2 B1 B0	E2 144 146	E2 136 174	E2 136 174
O O O O O	E2 144 146	E2 136 174	E2 136 174
O X O O O	M2 144 148	M2 136 174	M2 136 174
O O X O O	M2 144 148	M2 136 174	M2 136 174
X O O O O	X2 144 148	X2 136 174	X2 136 174
X O O X O	K2 144 148	K2 142 152	K2 136 174
X O O X X	K2 144 148	K2 142 152	K2 136 174

D15 D11 D14 D10 D8
O = Jumpered X = No jumper
.....<.....<.....<.....<.....<.....

Sub-UHF									
Reset	Offset	Shift	Auto	1750	Air	360	RX (Mhz)		
freq-	freq-	freq-	shift	tone	band	band	Min	Max	
144	0.6	12.5	0	0	0		400	520	
144	0.6	12.5	0	0	0	0	400	520	
144	0.6	12.5			0		400	520	
144	0.6	12.5			0	0	400	520	
144	0.6	5	0		0		400	520	
144	0.6	5	0		0	0	400	520	
144	0.6	5	0		0		438	450	
144	0.6	5	0		0	0	400	520	

Sub-UHF										
Reset	Step>.....								
freq.	freq.	:			430	25				
430	25	:			430	25				
430	25	:			440	25				
400	25	:			440	25				
400	25	:								

Table 2 TH48a/e

Destination bit													IGuaranteed		TX (Mhz)		RX (Mhz)	
B4	B3	B2	B1	B0	E3	E3	E3	M2	M2	X2	X2	K2	K2	Min	Max	Min	Max	
0	0	X	0	0	E3	E3	E3	M2	M2	X2	X2	K2	K2	430	440	400	470	
0	0	X	0	X	E3	E3	E3	M2	M2	X2	X2	K2	K2	430	440	400	470	
0	X	0	0	X	E3	E3	E3	M2	M2	X2	X2	K2	K2	430	440	400	470	
X	0	0	0	X	E3	E3	E3	M2	M2	X2	X2	K2	K2	430	440	400	470	
X	0	X	0	X	E3	E3	E3	M2	M2	X2	X2	K2	K2	438	450	400	470	
X	0	X	X	X	E3	E3	E3	M2	M2	X2	X2	K2	K2	438	450	400	470	

D15 D11 D14 D10 D8 :
O = Jumpered X = No jumper

Sub-VHF									
Reset	Offset	Shift	Auto	1750	360	800	RX (Mhz)		
freq-	freq-	freq-	shift	tone	band	band	Min	Max	
430	*	25		0			136	174	
430	*	25		0	0	0	136	174	

```

I      I I I      I
I      I_I_I      D10 D8      I
I      _ _ / _ /      I
I      D11-I I I I I      I
I      I_I_I I_I      I
I      _____      I

I      Control Unit      I
I      X53-3420-00 A/5      I
I      _____      I
I      : :      I
I      : CPU : _____      I
I      : : I_I I D1      I
I      : : I_I I D2      I
I      : .....: I_I I D3      I
I      : : I_I I D4      I
I      : : I_I I D5      I
I      : : I_I I D6      I
I      _____      I

```

This modification is read 1879 times.

[top of page](#)

19-07-1998

(TH-28) TH28 Send memory to other radio

To transfer memories from one radio to another, you can clone two TH-28a's.
Each radio must either have the ME-1 installed or no ME-1 installed, but they both must be the same!

Radio A will be the radio that SENDS the memories!

Radio B will receive the memories!

1. Turn on Radio B and enter say 144MHZ into all the memories you are going to CLONE TO.
2. Say radio A has 125 memories, enter 144MHZ into 125 of radio B's memories. This ENABLES or turns ON radio B's memories.
3. Turn both radios off then on.
4. Enter a simplex frequency into both radios and make sure you use the VFO mode.
5. Turn on radio A while pushing button 7 at the same time, the display should read "CLONE".
6. Turn on radio B while pushing button 7 at the same time, the display should read "CLONE".
7. Press PTT or push-to-talk on radio A!
8. You will hear tones on both radios which go real fast and vary in pitch.
9. Leave the radios for about 15-20 minutes so they can finish.
10. The tones will be repetitious-this will indicate the transfer was successful.
11. Turn off radio A, you might have to disconnect the battery.
12. Turn off radio B, then check the memories.

This does work, I tried it myself 125 memory transfer in 15 minutes PL's, odd offsets and all. Call channel is not transferred! If this does not work, try a few times.

Special thanks to N2OUM and N2PPT!

73 DE N2PPV

This modification is read 1276 times.

[top of page](#)

19-07-1998

(TH-28) Accus in BT8 (TH28/48/78)

Hallo (X)YLs, OMs and Kenwood TH 28-owners

It is possible to use your Kenwood TH 28 (but I think also in a similar modification your TH 48 or TH 78) with the Battery-Case BT8 and NiCd-Accus. But how can you charge them ?

** The proposal here worked fine with my equipment, but if you do not have proper tools, soldering-equipment and skill, please do not try this modification! I don't give any warranty and you perform this modification on your own risk and responsibility.

But nevertheless vy 55 ! **

If you look on the top-side of the BT8-case and the original BP13- accu you'll see the following (not to scale !)

TOP-VIEW

Accu (BP 13) Battery Case BT 8

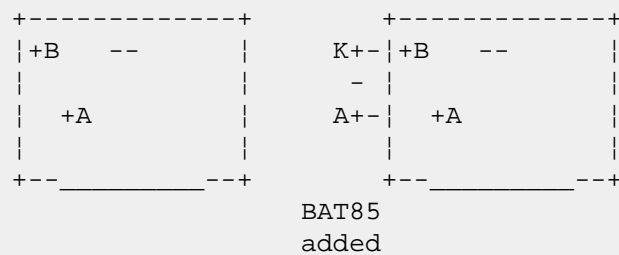

(+--_____--+ means the side of BP13/BT8 with the fixture-clamp)

+B means the battery-plus, +A the accu-plus

-- is the common grond (accu- and battery minus.)

DC-voltage is supplied to the DC-in jack of the TH28 and by this the +A gives the charging-current for the BP13 via an internal current-source

For charging NiCd-accus in the BT8 you only have to add a diode between +A an +B.

I used a Schottky-Diode BAT 85 (30V/200 mA) which has a lower flow-voltage than a silicium-diode, which will also work. (Anode to +A and Cathode to +B, so the charge-current will also go into the battery-pack and charge the NiCd there with ca. 60 mA.)

!! WARNING: So never use batteries with external DC-voltage supplied after this modification, as this will 'charge' the normal batteries, which might explode and cause serious damage not only to your TH28 !!!

I could not manage it to get the diode onto the top-side of the BT8, so I opened my TH 28 (see instruction-manual) and solderd this diode onto the leads of the built-in double-diode of the charger-board. (D 201 on board X53-3400-00). This requires a diode with a small case, a 1N4001 will be too big and has not enough thin wires to bend them for good soldering inside the TH28-case. (The diode D 201 disables the accu- or battery supply when the external DC-voltage is applied at the DC-in jack.)

The double-diode D201 you will find on one side of the charger-board, the two wires on one side go to +A and +B of the battery-case, check with ohm-meter.

Be careful not to damage the internal flexibel board connecting the keyboard/processor-unit and the rest...

I hope that this info might be useful as the original accu-packs of Kenwood are not the cheapest ones...

This modification is read 1286 times.

[top of page](#)

23-04-2000

(TH-28) TH-28/48/78 Difficult battery insertion

Author: Kenwood Communication, inc.

Service Bulletin no. 1028 (29 June 1993)

Symptom:

Insertion of the battery into the transceiver is difficult or impossible due to problems with the release lever.

Corrective Action:

- A temporary cure is provide by loosening the two screws securing the holder, shifting the holder to the extreme left, then retightening the screws.
- A permanent fix is provide by replacing the holder and release level with new parts that have been deburred and modified to allow relocation of the release level.

Parts required:

Qty	Description	Kenwood Part No.	Circuit description
1	Holder	J19-1515-23	NA
1	Release lever	D10-0610-13	NA

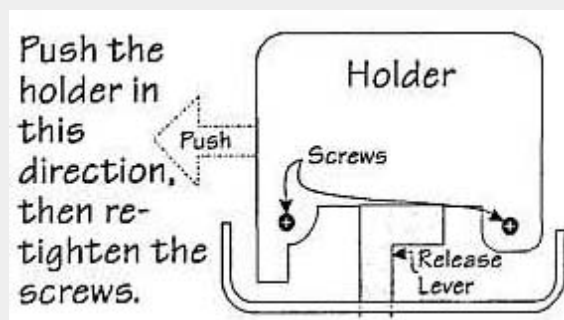

Time required for this modification is 30 minutes or less.

This modification is read 1209 times.

[top of page](#)

23-04-2000

(TH-28) TH-28/48A/E CTCSS tone error

Author: Kenwood Communication, inc.

Service Bulletin no. 1037 (18 March 1994)

Symptom:

Several reports were received on early model TH-28/48's concerning an inability to access sub-audible tone controlled repeaters. This symptom only occurred when the repeater required the use of any of the following tones:

131.8 Hz
136.5 Hz
173.8 Hz

Corrective Action:

A microprocessor software error is responsible for this symptom. Replacing microprocessor IC6 on board X53-3400 (TH-28) or X53-3410 (TH-48) with the part listed below will correct this symptom.

Parts required:

Qty	Description	Old part No.	New Part No	Circuit desc.
1	Microprocessor	HD404629A73H	HD404729A79H	IC6

Caution: This modification requires soldering equipment rated for CMOS type circuits. It also requires familiarity with surface mount soldering techniques. If you do not have the proper equipment or knowledge do not attempt this modification yourself. Seek qualified assistance.

Time required for this modification is 30 minutes or less.

This modification is read 1206 times.

[top of page](#)

21-04-2000

(TH-315) TH-205/215/315/415 PTT knob installation procedure

Author: Kenwood Communication, inc.

Service Bulletin no. 987 (11-6-1991)

The original plastic knob (K29-3054-15) has been replaced with a rubber knob (K29-3054-35). The PTT mounting guide on the front panel must be removed to allow the new knob to be installed. The following procedure will explain the installation procedure.

1. Disconnect the battery pack and antenna.
2. Remove the four screws from the back panel.
3. Carefully lift the front panel up and lay it into the right side of the body of the transceiver.
4. Disconnect the front panel from the body of the transceiver.
5. The plastic PTT knob is held in place with three tabs. Press in the bottom tab and then push the knob out of the front panel.
6. Push in the guide to crease it's two legs where they join the front panel.
7. Wiggle the guide back and forth until it breaks off the front panel. Discard the guide and plastic knob.
8. Install the rubber knob on the front panel. The side with the square tab goes toward the bottom of the front panel.

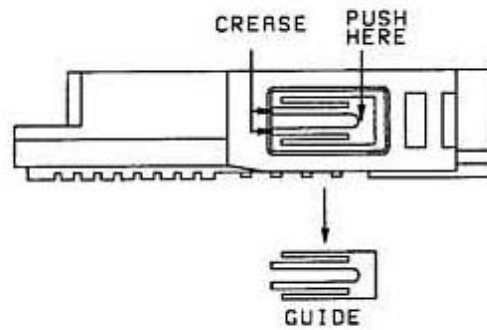
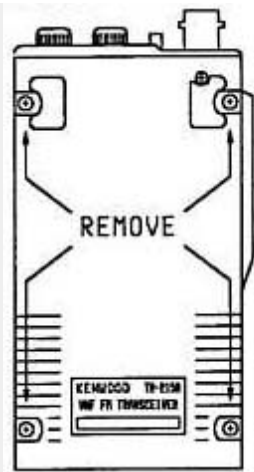

This modification is read 258 times.

[top of page](#)

19-07-1998

(TH-405) Umbau TH-405e auf 9k6

de DB8IE @ DB0SHG

Nach der grossen Resonanz auf meine Frage, ob eine Umbauanleitung des TH405 interessant sei, nun die Anleitung dazu:

Die vier Schrauben auf der Rueckseite loesen und dann vorsichtig die Vorderseite abheben. Dann die zwei Folienleiterbahnen aus den Fassungen ziehen.

Vorher die Arretierung an den Fassungen nach oben schieben.

Die Frontseite erstmal ausser Reichweite des Loetkolbens deponieren. Jetzt muessen Lautstaerke und Squelch-Drehknopf abgezogen werden.

Dazu von innen mit Schraubendreher etwas nachhelfen. Die drei Schrauben (eine oben und zwei unten) der oberen Platine loesen und dann die Platine nach oben rausziehen. Das geht etwas schwer, weil sie noch durch einen Steckverbinder gehalten wird.

Auf dieser Platine befindet sich unten rechts das Demodulator-IC IC 1, dort wird an Pin 9 direkt ein abgeschirmtes Kabel angeloetet, die Abschirmung davon irgendwo an einer Durchkontaktierung der Masseflaeche der Platine.

Dieses Kabel ist der NF-Ausgang zum Modem.

Damit ist die Empfangsseite schon erledigt, es folgt der Anschluss an den Sender:

Dieser wird an der Steckerleiste auf der Platine an Pin 12 vorgenommen.

Dazu ist der Elko C85, der unter der Steckerleiste sehr gut zu erkennen ist, ausgeoetet. Dort wo der Plusanschluss sass, also am rechten Loetauge, wird die Seele eines zweiten Koaxkabels eingeloetet. Die Abschirmung kommt wieder an Masse, also an die gleiche oder auch eine andere Durchkontaktierung wie das erste abgeschirmte Kabel. Mit dieser Leitung wird dem Sender das Modulationssignal zugefuehrt.

Das war schon der komplette Umbau, ich habe die beiden abgeschirmten Leitungen durch ein kleines Loch in der Seitenwand der Front nach aussen gefuehrt.

Der Haken an der Sache: Man kann jetzt den Modulationsverstaerker nicht mehr benutzen und nur noch in 9k6 arbeiten.

Abhilfe:

Drittes Koaxkabel rausfuehren, dabei den Elko links wieder mit dem Anschluss_ einloeten und den Pluspol mit der Seele des dritten abgesch. Kabels verbinden. Abschirmung wie gehabt an Masse. Bringt man am anderen Ende nun eine Klinkensteckverbindung an, so kann man NF-Ein und Ausgang des Funkgeraetes zusammenstecken und es auch wieder in Fonie oder 1k2 benutzen.

Was nicht so schoen aussieht, sind die nach aussen gefuehrten Kabel, aber fuer 3.5 mm Buchsen war leider etwas zuwenig Platz. Vielleicht faellt jemandem ja noch etwas Besseres ein?

Nach dem Zusammenbau sollte nun 9k6 Betrieb mit einem TX-Delay von 12-15 moeglich sein. Wichtig ist vor allen Dingen, das bei Empfang das Sendesignal des Modems abgeschaltet ist, also Jumper passend setzen! (Ich hatte das zuerst vergessen und wunderte mich ueber das starke Rauschen beim Empfang, hi.)

Lob auch an die Leute von Kenwood, die Funke ist sehr servicefreundlich aufgebaut und gut zugaenglich!

Also jetzt ran an den Loetkolben, es lohnt sich. Das Feeling in 9k6 laesst keinen Vergleich zu, man muss es mal erlebt haben.

Fuer etwaige "Unfaelle" mit dem Handy oder auch dem Loetkolben uebernehme ich im uebrigen null Haftung, aber Ihr werdet das Ding schon kaputt kriegen, hi!

73 & 55 von Frank, DB8IE @ DB0SHG-1

This modification is read 263 times.

[top of page](#)

16-04-2000

(TH-415) TH-205/215/415 Volume/squelch control improvement

Author: Trio-Kenwood Communication, inc.

Service Bulletin no. 944 (28-10-1988)

The transceivers mentioned above can be mechanically improved by adding a bracket assembly to the volume and squelch controls. The bracket assembly is being used in current production and is available for older units from the Kenwood Parts Department.

Bracket Ass'y (W05-0235-00)

1. Disconnect the battery pack and antenna.
2. Remove the 7 screws from the panel of the transceiver (Figure 1).
3. Lift the front panel from the transceiver and lay it to the right side.
4. Disconnect the 2 flex cables and remove the 3 screws from the IF unit (Figure 2).
5. Pull the top panel off and then remove the IF unit.
6. Remove the knobs and black cloth from the volume and squelch controls.
7. Inspect the controls to insure they are mounted flush to the board. If they are not flush, completely desolder and resolder the controls.
8. Insert the bracket over the controls and tighten the nuts (tighten the nut on the volume control first). See figure 3 for the bracket assembly view.
9. Assemble the transceiver by reversing steps 1 - 6.

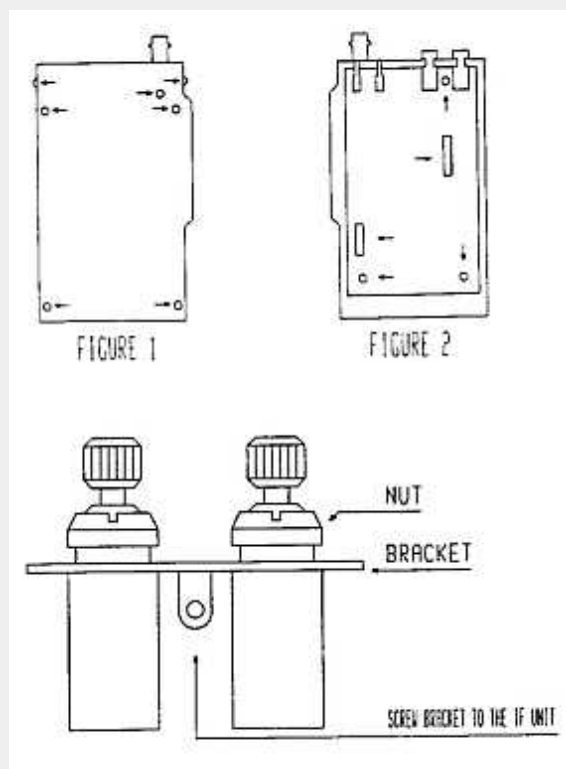

This modification may be covered under warranty.
Time required for this modification is ½ hour or less.

This modification is read 472 times.

[top of page](#)

16-04-2000

(TH-415) TH-215/415 TX signal-To-Noise ratio improvements

Author: Trio-Kenwood Communication, inc.

Service Bulletin no. 946 (28-10-1988)

The TH-215/415 transmit signal-to-noise ratio is typically 30 dB. This ratio is more than sufficient for routine operations. For those users who would like to obtain additional performance, the following modification will provide an improvement of 5 to 8 dB.

Required parts:

47 ohm 1/10 watt chip resistor	(RK73FB2A470J)
220 ohm 1/10 watt carbon resistor	(RD14BB2B221J)
22 μ F 6.3V Electrolytic capacitor	(CE04CW0J220M)
1 μ F 50V Electrolytic capacitor	(C90-1248-05)

1. Disconnect the battery and antenna.
2. Remove the 7 screws from the back panel of the transceiver (figure 1).
3. Lift the front panel from the transceiver and lay it to the right side.
4. Disconnect the 2 flex cables and remove the 3 screws from the IF unit (figure 2).
5. Pull the top panel off and then remove the IF unit.
6. Remove the 8 screws from the RF unit and unplug connector CN2 (figure 3). Remove the RF unit from the back cover.
7. Locate R50 (TH-215) or R60 TH-415) on the foil side of the RF unit (figure 4). Replace the resistor with a 47 ohm chip resistor.
8. On the component side of the IF unit, add a 1 μ F capacitor as shown in figure 5.
9. Also on the component side, cut one foil, add a 220 ohm resistor, and add a 22 μ F capacitor as shown in figure 6.
10. Assemble the transceiver by reversing steps 1 - 6.

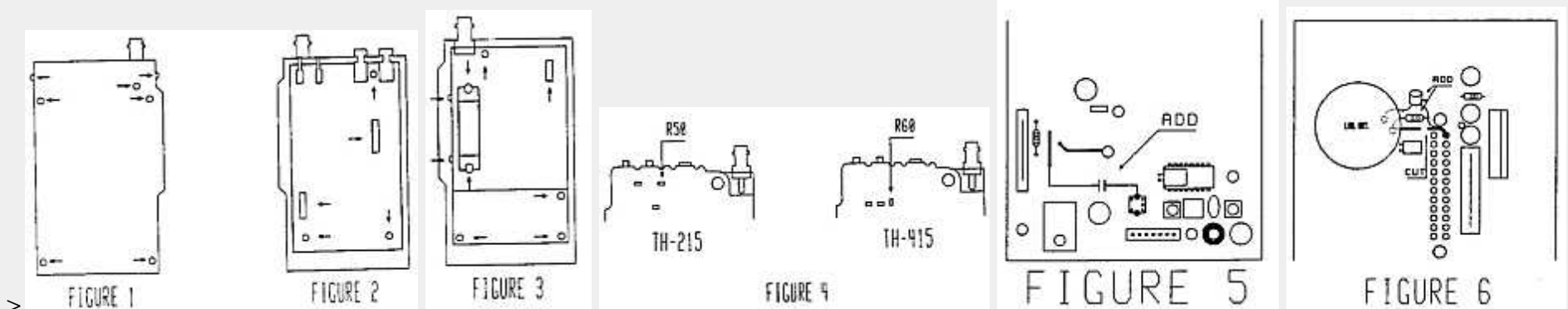

This is an optional change that may not be covered under warranty.
Time required for this modification is 1 hour or less.

This modification is read 475 times.

[top of page](#)

21-04-2000

(TH-415) TH-205/215/315/415 PTT knob installation procedure

Author: Kenwood Communication, inc.

Service Bulletin no. 987 (11-6-1991)

The original plastic knob (K29-3054-15) has been replaced with a rubber knob (K29-3054-35). The PTT mounting guide on the front panel must be removed to allow the new knob to be installed. The following procedure will explain the installation procedure.

1. Disconnect the battery pack and antenna.
2. Remove the four screws from the back panel.
3. Carefully lift the front panel up and lay it into the right side of the body of the transceiver.
4. Disconnect the front panel from the body of the transceiver.

5. The plastic PTT knob is held in place with three tabs. Press in the bottom tab and then push the knob out of the front panel.
6. Push in the guide to crease it's two legs where they join the front panel.
7. Wiggle the guide back and forth until it breaks off the front panel. Discard the guide and plastic knob.
8. Install the rubber knob on the front panel. The side with the square tab goes toward the bottom of the front panel.

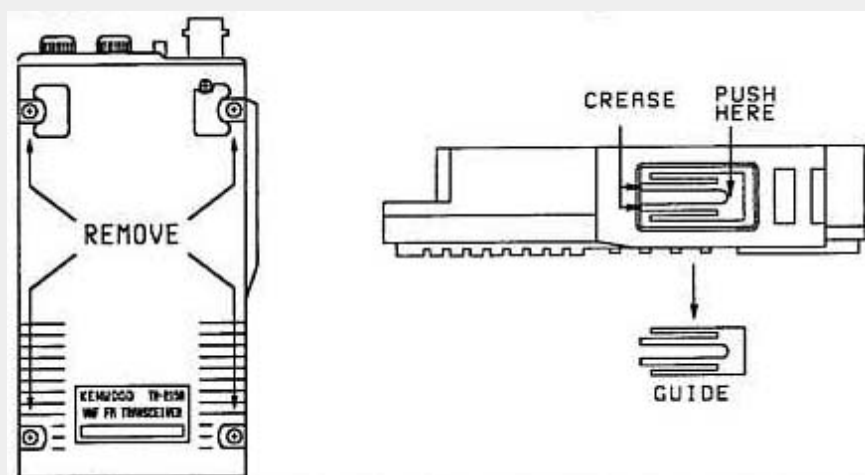

This modification is read 465 times.

[top of page](#)

23-04-2000

(TH-42) TH-22/42A/E Memory loss improvement

Author: Kenwood Communication, inc.

Service Bulletin no. 1057 (28 March 1994)

Symptom:

Memory loss can occasionally occur if the following procedure is observed:

1. Program the memory with any desired information.
2. Allow the battery pack with to drain down over an extended period of time without turning off the transceiver. For example turn the volume control up and squelch off. After approximately 8 hours the battery voltage will drop to approximately 3 - 4 Vdc.
3. Turn off the POWER SW.
4. Connect a DC voltage supply or a fully charged battery pack.
5. Turn on the POWER SW.
6. Memory will have been lost.

Corrective Action:

Replace microprocessor IC206 with the improved part listed below. This part incorporates an software improvement to correct this symptom.

Parts required:

Qty	Description	Old part No.	New Part No.	Circuit Description
1	Microprocessor	HD404629B17TF	HD404629B49TF	IC206

Time required for this modification is 60 minutes or less.

This modification is read 364 times.

[top of page](#)

19-07-1998

(TH-45) KENWOOD TH-25/45 out of band modifications

Here are some mods for the TH-25AT and the TH-45AT. Please note that I do not encourage transmitting on a frequency for which you do not have a license, nor do I encourage transmitting on a non-amateur frequency without FCC type accepted equipment (in the United States).

First let me recommend that you buy the service manuals for these radios. The service manual is not expensive (about \$15 I think) and it will greatly help you in performing these modifications.

Look at the schematic for your radio. In the lower left hand corner is an IC labeled IC2. This is an ASIC microprocessor. At the lower right hand corner of this uP are several diodes and pull-up/pull-down resistors. They are D4, D3, R19, R18, R28, R20, R21, R22, R25, R26, and a couple of resistors that are not even on the schematic that attach to B2 (pin 51 on IC2) and B3 (pin 50 on IC2). The TH-45AT schematic shows R23 on the ASIC uP pin B2.

The schematic for the TH-25AT shows:

			R18-R21	R25	R26, 27	R28	R36
TH-25A	M, M2	-12	0	X	X	X	X
TH-25A	M3, M4, X	-23	0	X	X	0	X
TH-25AT	K	-11	0	0	X	X	X
TH-25AT	M, M2	-12	0	X	X	X	X
TH-25E	T	-52	X	X	0	0	0
TH-25E	W	-62	X	0	0	0	0

And the schematic for the TH-45AT shows:

			R19-R21	R22	R23	R25	R26, 27	R28	R36
TH-45A	M1, M2, X	-21	0	0	0	X	X	0	X
TH-45A	M3, M4	-22	0	X	0	X	X	X	X
TH-45AT	K	-10	0	X	0	X	X	0	X
TH-45AT	M1, M2	-21	0	0	0	X	X	0	X
TH-45AT	M3, M4	-22	0	X	0	X	X	X	X
TH-45E	T	-51	X	0	X	X	0	X	0
TH-45E	W	-61	X	0	X	0	0	0	0

where 0 means USED, and X means NOT USED.

On the TH-25AT:
(All frequencies given in MHz.)

R22 in
R28 out

This is how the radio is delivered in the USA. TX 144-1, 141-163
(I think).

R22 out
R28 in

The radio tunes from 142-151. This may be the modification given to US MARS members. I don't remember where the unit will transmit. It may or may not transmit outside the range from 144-148.

R22 in
R28 in

The radio tunes only from 144-148.

R22 out
R28 out

Frequencies may be selected from 100-200 MHz (on the display only - your PLL will not lock up in this entire range). In addition, TX is possible where your PLL locks up.

R25 out
Removing R25 disables automatic offset selection.

R23 and R24 are used for selecting the step size for tuning. I can't remember which positions are for which step sizes, and alas I didn't write down what I found. If you want to play with this, go ahead.

On the TH-45AT:
(All frequencies are given in MHz.)

R18 in
R28 in

This is how the radio is delivered in the USA. The radio covers 438-450 MHz.

R18 in
R20 out

The radio is prohibited from tuning outside 440-450 MHz.

R18 out

R28 in

The radio will only tune from 215-230 MHz. Note that the PLL would not lock up! (What did you expect?) Could it be possible that Kenwood originally planned a 220 version of this radio, but then scrapped their plans?

R18 out

R28 out

The radio will tune from 200-500 MHz (on the display only - your PLL will not lock up over this entire range). Transmitting is possible anywhere your PLL will lock up.

Some of the above codes are:

K USA
T England
X Australia
M Other Areas

These components are found on the flexible circuit board under the display. To get to them, take the radio apart. Some unsoldering of obvious grounding wires may be necessary. You will see where the flexible circuit board plugs into a socket on the main circuit board. Before unplugging it, make sure you know what's in the memories, because they will be lost. Unplug the flexible circuit board and unfold it so that the components are accesable. One of the fold-out parts of the flexible board will look something like this:

```
+-----+
! R  R R D3 R R !
! 2  2 2   7 2 !
! 5  3 2   1 !
!
! R  O      O R20!
! 2  O      O R19!
! 6  O      O R18!
!   O      O R28!
!
!           R !
!         D4 6 !
!       +-----+
!       !
!       !
```

The O's are solder pads.

The fold out board is actually square, but with only characters for graphics, I couldn't draw it that way.

On both radios, R36 is for the European tone burst to "whistle up" repeaters.

On both radios, D4 is for selecting the type of display. With D4 in, the display is normal. With D4 removed, the display is a channel display.

D3 is for selecting VHF or UHF. With D4 in, the radio thinks its a VHF radio. With D4 removed, the radio thinks its a UHF radio. Don't change this on your radio.

I have found a quick and easy way to retune your PLL (in the TH45-AT) with a minimum of test equipment. All you need is a scope and a small tuning tool. First, take off the battery pack holder plate. Then, remove the silvery sticker covering the tuning pot access holes. If the radio is positioned on its back, with the top folded over so that the touch tone pad is also facing down, the test point you want (TP1) is on the bottom half of the radio, near the center (left to right), and close to the battery; the tuning pot you want (TC1) is on the bottom, and closest to the PTT switch. Under no circumstances change the tuning of TC51. This is used to calibrate the output of the radio with the display the radio is giving; you don't want to mess with it. Once again, the Service Manual makes it very clear where these points are, if you are having trouble with my descriptions. On with retuning the PLL.

With the radio on, and receiving, monitor the voltage and the waveform on test point TC1.

Tune the radio DOWNWARDS in frequency until the PLL unlocks. Note that the radio will beep when this happens, and the waveform on TP1 will change. Tune the radio about 1 MHz higher so that the PLL locks up again, and note the voltage on the testpoint, TP1. Now, tune the radio to the LOWEST frequency that you want to be able to receive. Adjust TC1 until the voltage on the test point TP1 is the same as what was noted earlier. Button the radio back up, and you're done. You will not be able to tune the PLL to any range you want.

There are limits. On my radio, I have been able to retune the radio so that I can recieve from 439.2-468.6 MHz with a set of batteries fresh out of the charger. The tuning range will probably diminish as the battery voltage decreases. I have not retuned the PLL on my 2m HT, but I'd imagine the same technique will prove fruitful.

I may have some more information on these radios someplace. If I can find it, I will add to this posting, and post it again with the updated information. Enjoy. Kenneth J. Hendrickson N8DGN

19-07-1998

(TH-45) TH-45E auf 9k6

From: DL5RDO @ DBORGB.#BAY.DEU.EU

Hallo OMs,

hier ist eine Modifikationsanleitung für das TH45E von Kenwood zum Betrieb mit 9600 Baud:

1. Öffnen des Geräts

- Batteriepack abnehmen
- die 4 Schrauben für die Batterie-Kontaktplatte entfernen
- die beiden Schrauben rechts am Rückteil entfernen
- die Schraube, die sich links in einer Aussparung des Rückteils befindet, ebenfalls entfernen.
- vorsichtig das Kunststoffvorderteil des Geräts abziehen.

2. Abnehmen der Weißblechabschirmung

Im Gerät befindet über den Platinen eine Weißblechabschirmung, die mit insgesamt sieben Schrauben befestigt ist. Diese Schrauben alle entfernen. Danach die beiden Lötstellen oben an der Abschirmung lösen und die entsprechenden Drähte vorsichtig zur Seite biegen. Das Blech kann dann abgenommen werden.

3. RX-Anschluß

Auf der IF-Platine (die dritte, stehend eingebaute Platine, von rechts gezählt) befindet sich das ZF-IC TK 10485 M. An Pin 11 dieses ICs ist ein geschirmter Draht anzulöten. Der richtige Pin ist derjenige, der zu einem SMD-Kondensator geht. (Wenn das Gerät mit der rechten Seite nach unten liegt, ist es der obere rechte Pin). Man sollte möglichst auch den Anschluß der Abschirmung vor dem Zusammenbau an die Weißblechplatte anlöten.

4. TX-Anschluß

Die (am besten zugänglichste) Stelle für den TX-Anschluß ist das Hubpoti.

Es ist schon vor dem Abnehmen der Weißblechabschirmung im unteren Teil des Geräts erkennbar. (Daneben befindet sich ein isolierter Draht.)

An den rechten Anschluß des Potis ist ein ebenfalls geschirmter Draht anzulöten. Auch hier wieder Masseanschluß an die Weißblechplatte.

Der andere Anschluß am Poti geht übrigens nach Masse, was mit einem Ohmmeter leicht zu verifizieren ist, falls Unklarheit über den richtigen Pin herrscht. Keinesfalls am Hubpoti herumdrehen, der Hub wird im TNC eingestellt!

5. PTT-Anschluß

Man kann der Einfachheit halber den PTT-Anschluß von außen über die MIC-Klinkenbuchse vornehmen. Wer will, kann auch innen anschließen. Nach Abschrauben der beiden Buchsen ist die entsprechende Stelle leicht zugänglich.

6. Zusammenbau

Prinzipiell ist umgekehrt wie unter 1. und 2. vorzugehen. Dabei aber nicht vergessen, die Drähte an die Weißblechplatte wieder anzulöten.

7. Herausführen der Drähte

Durch die Kompaktheit des Geräts bedingt ist es nicht einfach, die Drähte nach außen zu führen. Eine Lösung wäre, die Anschlüsse an den Klinkenbuchsen zu benutzen. Dann kann man aber leider kein Speakermike mehr verwenden. Ansonsten bleibt es jedem selbst überlassen, wie er es am geschicktesten anstellt. (Ich weiß es übrigens selbst noch nicht...)

8. Test und TNC-Einstellungen

Bei mir wird ein TNC2H von DK9SJ verwendet, alle Angaben beziehen sich darauf. Empfangsmäßig sollte das Gerät auf 9k6 sofort funktionieren.

Auf der Senderseite ist es schon schwieriger, da die Hubeinstellung sehr kritisch ist. Bei mir ist das Hubpoti im TNC etwa ein Viertel aufgedreht.

Hier ist u. U. längeres Probieren angesagt.

Beim Sendefilter hat sich bei mir die Einstellung 3 als die beste erwiesen. (Also die beiden rechten DIP-Schalter nach oben.)

Zwar habe ich den Eindruck, daß beim Senden gelegentlich ein Paket verloren geht, aber im allgemeinen kann man damit recht gut arbeiten.

TXDelay ist auf 180 ms gesetzt. (Parameter T= 18)

9. Abschließende Bemerkungen

Ich hoffe, daß ich mit dieser Beschreibung dem einen oder anderen OM den Einstieg in die 9k6-Welt ermöglicht habe. Sollten Unklarheiten über die Modifikation bestehen, bin ich gerne bereit, noch genauere Infos zu geben.

19-07-1998

(TH-45) TH-25/45AT Automatic Power OFF Function

Author: *Trio-Kenwood Communication, inc.*

Service Bulletin no. 939 (2-6-1988)

Some users of the TH-25AT/45AT have expressed a desire to defeat the automatic power off function. The following modification will explain how to do this. It should be noted that this modification does not effect the battery saver function.

Required Part:

Diode Kenwood Part #1SS133

1. Disconnect the battery pack and antenna.
2. Remove the Volume, Squelch, and Tuning Control knobs by pulling them straight up from the top panel.
3. Using a 7mm spanner wrench, remove the nut from the volume control and the nut from the tuning control.
4. Remove one screw located by the PTT switch. (Figure 1).
5. Remove one screw located by the speaker jack. (Figure 2).
6. Remove two screws from the battery terminal plate. (Figure 3).
7. Carefully pull the front panel up from the transceiver (do not break the wires connected between the front panel and the body of the transceiver.) Lay the front panel to the side of the transceiver (Keep track of the F.LOCK cover if it comes off.)
8. Remove the PTT cover.
9. Remove one screw from the PTT switch unit. (Figure 4).
10. Gently lift the top panel from the transceiver by pulling it forward and then up (the O ring on the BNC connector will produce some tension.)
11. Carefully unfold the flex Printed Circuit Board (PCB) to expose IC2. (Figure 5).
12. Using a 45 watt (or less) soldering iron that has an isolated or grounded tip, add a diode between pins 23 and 58 of IC2. (Figure 6).
13. Carefully assemble the transceiver by reversing step 1-11. Pull the BNC connector "O" ring up a little before installing the top panel.
14. Reset the microprocessor by following the procedure in the instruction manual (page 16) called CLEARING ALL MEMORY.



FIGURE 1



FIGURE 2



FIGURE 3

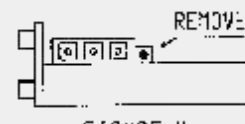

FIGURE 4

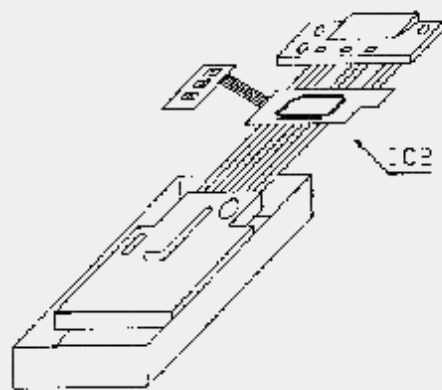

FIGURE 5

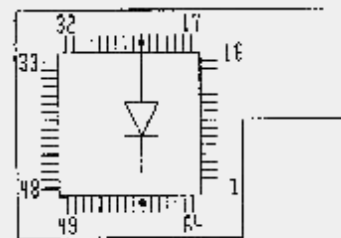

FIGURE 6

This is an optional change that is not covered under warranty.
Time required for this modification is 1 hour or less.

SYSOP NOTES:

Later versions of the TH-25/45AT came with a programmable defeat for the Auto power off function. Do not install this modification if your manual provides a procedure for turning the power off function off! Step 11 tells you to carefully unfold the flexible pc board. It is extremely important that you do not try and bend the board in a direction that is opposite from its current bend. To do so will break the board or the foil traces inside the board!

This modification is read 481 times.

[top of page](#)

16-04-2000

(TH-45) TH-25/45 W/TSU-6 Tone alert improvements

Author: Trio-Kenwood Communication, inc.

Service Bulletin no. 932 (11-4-1988)

When using the TH-25/45 in combination with the TSU-6 you may experience erratic operation of the tone alert function. This may be due to an incoming signal that is over-modulated, distorted, or noisy. The following modification will correct this tendency.

Required parts:

22 μ F, 6.3V electrolytic capacitor	part # CE04CW0J220J
56 Kohm, 1/8 watt carbon resistor	part # RD14BB2B563J
Diode	part # 1SS133

1. Remove the TSU-6 from the TH-25/45 (refer to the TH-25/45 instruction manual for details).
2. Cut the blue wire (pin # 4) approximately 5 mm from the connector for the TSU-6.
3. Solder the components to the blue wire and ground as shown in figure 1. Note that the cathode side of the diode goes toward the TSU-6 connector. Use the leg of the VCO shield to ground the negative side of the capacitor.
4. Insulate the components with electrical tape to prevent shorting.
5. Install the TSU-6 in the TH-25/45. Route the components so that the battery terminal plate does not bow when installed.

Figure 1.

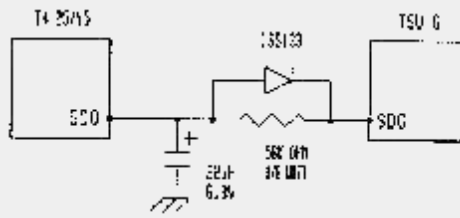

This modification may be covered under warranty.
Time required for this modification is ½ hour or less.

This modification is read 478 times.

[top of page](#)

12-03-2000

(TH-46) Extended RX/TX for TH-46

Level of extension	Ordinary extension	Reception extension	Transmission/Reception extension
Modification (width R20)	Cut b0 (JP1)	Delete b1	Delete a6 (&24,R21, and R20)
Destinations Label	K	W	All
Transmission	400 ~ 470	400 ~ 470	400 ~ 500
Reception	400 ~ 470	400 ~ 470	400 ~ 500
Guide values of	405 ~ 460	405 ~ 460	405 ~ 460
PLL lock ranges*	405 ~ 460	405 ~ 460	405 ~ 460

* The PLL lock ranges are guide values. Unstable operation may occur around the upper/lower limits of frequency. For use at frequencies around the upper/lower limits of the lock range or outside the lock range, readjust the lock range.

Adjusting the lock range:

TX-RX unit X57-3520-21. VCO coil L1 (Common transmission/reception.)

Date: 12-03-2000

User comment

From: [webmaster](#)

Subject: Blurred text.

Under the table "Reception/Modification" the label "Delete a6 (&24,R21, and R20)", I'm not sure about the text "&24", maybe the "&" character is another character. It was a very bad picture I have to read from.

Mail me if you have any changes

This modification is read 369 times.

[top of page](#)

19-07-1998

(TH-47) TH-47A Mods for ext frq

1. Remove battery and antenna.
2. Remove case as follows: Remove volume, squelch and tuning knobs by pulling straight off. Remove shaft nuts using needle nose pliers or other such tool. Remove 4 screws from the case. NOTE: Do not remove the 2 screws that are on either side of battery release latch. Lift plastic top from radio while separating the radio halves.
3. Open the radio up like a book and place on work surface.
4. Cut or unsolder green wire loop on the control board.
5. Reassemble radio, Reset microprocessor.

Radio will cover 400-470 MHz. While scanning, a beeping sound will be heard at the band edges indicating PLL unlock condition. To eliminate this annoyance:

1. Open up radio as indicated above.
2. Lift up microprocessor IC303 leg # 62 (This is the bottom microprocessor) (Third leg on left side from the bottom) This should be done only by those comfortable working with SMT components.
3. Reassemble radio.

Radio will now cover 400-470 MHz RCV/XMIT with no annoying beeps during scanning. Leg # 62 is the UL input to the microprocessor to tell it that an unlock condition is occurring. With no input, the Microprocessor thinks that the radio is always locked, and no error beeps will sound. This MOD also allows XMIT, but that is the price you have to pay :-)

I have done this MOD to my radio with no ill effects. This MOD should also work on the TH-27A.

This modification is read 293 times.

[top of page](#)

19-07-1998

(TH-48) Secret function manual of the KENWOOD TH-28e/48e porto

TH-28e/48e RX EXPANSION (ON)

Press PTT + VFO, then POWER ON.

New RX ranges TH28e after this modification:

VHF Band 136 - 174 Mhz (FM)

UHF Band 400 - 520 Mhz (FM)

TH48e:

UHF Band 400 - 470 Mhz (FM)

VHF Band 136 - 174 Mhz (FM)

TH28e Air Band Expansion

Press F key for 1 sec. Then press LOW key.

New RX ranges

108 - 118 Mhz (FM)

118 - 136 Mhz (AM)

TH28e 340 - 400 Mhz Expansion

Remove the diode D8 from the control unit. (FM mode only) With Air Band and 340 Mhz expansion, operating band can be changed:

```
----->I AMATEUR I====I 340 Mhz I--->I AIR BAND I_____
I I_____I I_____I I_____I I
I_____I
```

TH48e 340 MHz & 900 MHz EXPANSION

Remove the diode D8 from the control unit to cover 340 - 400 Mhz and 800 - 950 Mhz FM mode.

```
---->I AMATEUR I--->I 340 Mhz I--->I 900 Mhz I_____
I I_____I I_____I I_____I I
I_____I
```

TH-28e/48e TX EXPANSION

Remove the diode D10 from the control unit.

New TX ranges after this modification:

TH28e:

VHF Band 136.000 - 174.250 Mhz (FM)

TH48e:

UHF Band 400.000 - 470.000 Mhz (FM)

Note:

Manufacturer guarantees TX/RX specification only in amateur band. The above frequency range is for the microprocessor's range so that the receiver sensitivity or TX output power of expanded band may be reduced.

TH-48E TX/RX 432-438 Mhz LIMITED RANGE

Remove the diode D14 from the control unit.

TH28e/48e CROSS BAND REPEATER

Remove the diode D4 then press F key for 1 sec. and press 0 key.

TH-28a/e-48a/e FREQUENCY EXTENSION

Open the case and remove or add the destination chip diode D10, D11, D14 and D15 on the component side of the control unit. (X53-340X-XX, X53-341X-XX)

The frequency can then be extended as shown in the table 1 and 2 on page 3 and 4. (See the destination chip diode position drawing on the attached sheet.)

Notes:

The frequency display range may differ from the PLL lock range.

	360-Mhz band	Air band
Step	5,10,15,20,12.5,25 Khz	5,10,15,20,12.5,25 Khz
Frequency range	340.000-399.987.5 Mhz	100.000 - 117.975 Mhz
	FM	FM
		118.000 - 135.995 Mhz
		AM
Initial frequency	340.000 Mhz	118.000 Mhz

Initial step value is 12.5 Khz for 360-Mhz band and 25 Khz for Air band.

TH-48a/e BAND EXTENSION

The 360 Mhz band and the 800 Mhz band can be received. To expand the 360-Mhz band and the 800-Mhz band remove chip diode D8 of the control unit as shown in table 2.

You can switch between the UHF amateur band the 360-Mhz band and the 800-Mhz band by pressing the [F] key for 1 sec. and then the [LOW] key.

	360-Mhz band	800-Mhz band
Step	5,10,15,20,12.5,25 Khz	12.5,25 Khz
Frequency range	340.000-399.987.5 Mhz	800.000-949.987.5 Mhz
	FM	FM
Initial frequency	340.000 Mhz	850.000 Mhz

Note:

Program scan is not possible over several bands, but is possible within each band.

Initial step value is 12.5 Khz.

Table 1 TH28a/e

Destination bit	Guaranteed	TX (Mhz)	RX (Mhz)	
B4 B3 B2 B1 B0	Min Max	Min Max	Min Max	
O O O X O	E2 144 146	136 174	136 174	
O O O X X	E2 144 146	136 174	136 174	
O X O O X	M2 144 148	136 174	136 174	
O X O O X	M2 144 148	136 174	136 174	
X O O O X	X2 144 148	136 174	136 174	
X O O O X	X2 144 148	136 174	136 174	
X O X O X	K2 144 148	142 152	136 174	
X O X O X	K2 144 148	142 152	136 174	
D15 D11 D14 D10 D8				:
O = Jumpered X = No jumper				:

										Sub-UHF	
Reset	Offset	Shift	Auto	1750	Air	360	RX (Mhz)				
freq-	freq-	freq-	shift	tone	band	band	Min	Max			
144	0.6	12.5	0	0	0	0	400	520			
144	0.6	12.5	0	0	0	0	400	520			
144	0.6	12.5				0	400	520			
144	0.6	12.5				0	400	520			
144	0.6	5	0			0	400	520			
144	0.6	5	0			0	400	520			
144	0.6	5	0			0	438	450			
144	0.6	5	0			0	400	520			

										Sub-UHF	
Reset	Step							RX (Mhz)			
freq.	freq.							Min	Max		
430	25							430	25		
430	25							440	25		
400	25							400	25		
400	25							400	25		

Table 2 TH48a/e

										Sub-VHF	
Destination bit					IDest	Guaranteed	TX (Mhz)		RX (Mhz)		
B4	B3	B2	B1	B0		Min	Max	Min	Max	Min	Max
O	O	X	O	O	E3	430	440	400	470	400	470
O	O	X	O	X	E3	430	440	400	470	400	470
O	X	O	X	O	M2	430	440	400	470	400	470
O	X	O	X	X	M2	430	440	400	470	400	470
X	O	O	X	O	X2	430	440	400	470	400	470
X	O	O	X	X	X2	430	440	400	470	400	470
X	O	X	X	O	K2	438	450	400	470	400	470
X	O	X	X	X	K2	438	450	400	470	400	470

D15 D11 D14 D10 D8 :
O = Jumpered X = No jumper :

										Sub-VHF	
Reset	Offset	Shift	Auto	1750	360	800	RX (Mhz)				
freq-	freq-	freq-	shift	tone	band	band	Min	Max			
430	*	25		0			136	174			
430	*	25		0	0	0	136	174			

```

I-----I-----I-----I-----I-----I-----I-----I-----I-----I
I  430 I   5   I  25 I   I   I   I   I   I  136 I  174 I
I-----I-----I-----I-----I-----I-----I-----I-----I-----I
I  430 I   5   I  25 I   I   I   I   0   I   0   I  136 I  174 I
I-----I-----I-----I-----I-----I-----I-----I-----I-----I
I  430 I   5   I  25 I   I   I   I   I   I   I  136 I  174 I
I-----I-----I-----I-----I-----I-----I-----I-----I-----I
I  430 I   5   I  25 I   I   I   I   0   I   0   I  136 I  174 I
I-----I-----I-----I-----I-----I-----I-----I-----I-----I
I  440 I   5   I  25 I   I   I   I   I   I   I  136 I  174 I
I-----I-----I-----I-----I-----I-----I-----I-----I-----I
I  440 I   5   I  25 I   I   I   I   0   I   0   I  136 I  174 I
I-----I-----I-----I-----I-----I-----I-----I-----I-----I

```

* = 1.6M, -7.6M

```

.....<.....<.....<.....<.....<.....<.....:
:
:

```

Sub-UHF I

```

I Reset I Step I .....>.....I-----I-----I
I freq. I freq.I : I 144 I 5 I
I I I : I-----I-----I
I-----I-----I : I 144 I 5 I
I 144 I 12.5 I : I-----I-----I
I-----I-----I : I 144 I 5 I
I 144 I 12.5 I : I-----I-----I
I-----I-----I : I 144 I 5 I
I 136 I 12.5 I : I-----I-----I
I-----I-----I :
I 136 I 12.5 I :
I-----I-----I.....>.:

```

CLONING BY RADIO

1. Overview of the clone function. (The function does not require frequency expansion.)
Since 240 channels are available if an option is installed, it is laborious to write the same memory channel frequency data into several transceivers. Once you write data into one transceiver, you can duplicate it in several others in a single operation with the clone function. (You can write data without installing an option.)
2. How to use the clone function.

Transmitter setup:

1. Write the required memory channel frequency data into the transceiver.
2. Set the transmit frequency.
3. Switch the power off, hold down the 7 key on an F series transceiver or the MR and PTT keys on a K series, and switch the power on again.

"CLONE" appears on the display.
(The transmit output is automatically set to "economic low".)

Receiver setup:

1. Set the frequency of the transceiver to the transmit frequency of the transmitter.
2. Switch the power off, hold down the 7 key on an F series transceiver or the MR and PTT keys on a K series one, and switch the power on again.

"CLONE" appears on the display.
Press the PTT key on the transmitter. The clone function works automatically. When cloning ends, the frequency is displayed again.

It takes about four minutes to transfer frequency data for 40 channels, and about nine minutes to transfer frequency data for 240 channels.

If the receiver is an F series one and the frequency is displayed again, switch the power off, hold down the F key, and switch the power on again (VFO reset). If the receiver is a K series one and the frequency is displayed again, switch the power off and on again.

Thus, cloning lets you copy the channel data stored in the transmitter to other transceivers in a single operation. To stop cloning, switch the power off and on again.

```

I
I          Control Unit
I
I          TH28a/e : X53-340X-XX
I          TH48a/e : X53-341X-XX
I
I
I
I
I
I
I
I
I

```

```

I
I          Bit 0.....D8   (MA110)
I          Bit 1.....D10  (MA110)
I          Bit 2.....D14  (MA110)
I          Bit 3.....D11  (MA110)
I          Bit 4.....D15  (MA110)
I
I
I
I
I
I

```

```

I   D15      D14      I
I   \_ _ /      I
I   I I I      I
I   I_I_I      D10 D8  I
I   _ _ / _ /      I
I   D11-I I I I I  I
I   I_I_I I_I      I
I   _____ I

```

```

I
I   Control Unit      I
I   X53-3420-00 A/5   I
I
I   .....           I
I   :                 I
I   : CPU           :  ___ I
I   :                 : I___I D1  I
I   :                 : I___I D2  I
I   : .....:         : I___I D3  I
I   :                 : I___I D4  I
I   :                 : I___I D5  I
I   :                 : I___I D6  I
I
I   _____ I

```

This modification is read 852 times.

[top of page](#)

27-03-2000

(TH-48) Extended UHF TX. Also VHF/UHF/Cellular RX Modification

Author: Colin G1IVG - colinlowe@jet.es. MODIFICATION.NET

RX Coverage After Modification.

```

VHF.      136 MHz to 174 MHz FM
UHF.      340 MHz to 470 MHz FM
Cellular. 800 MHz to 950 MHz FM

```

(To select the different UHF bands after the modification you must make sure that you are in UHF VFO mode, then press for two two seconds and then . This toggles the different UHF bands).

Procedure.

1. Remove the battery.
2. Remove the four screws on the rear of the radio (not the belt clip screws).
3. To open the radio, I found it best to put your thumb into the battery compartment and by applying slight pressure on the inside of the rear cover, with your thumb the radio will open.
4. As you open the case, take care not to damage the ribbon cable.
5. Put the radio face down on a clean surface with the front of the radio facing down and to the right. The back of the radio should then be to the left and on it's back.
6. Look at the photo below for the location of the surface mount resistors.
7. On my radio, originally there were two green link wires fitted to the PCB. The photo below shows my radio after modification. The wire link to remove is "W1". However leave link "W2" in place.
8. Now you need to configure the small surface mount resistors as shown in the photo. Just copy the configuration as shown and this will give you the coverage printed above. Take care when removing the resistors as too much heat from your soldering iron will lift the PCB track and possibly destroy your Kenwood TH48. If your not sure then ask an experienced technician to do the soldering etc.
9. Then reassemble the radio, taking care not to trap the existing link wire "W2" between the two parts of the case. Also take care again of the ribbon cable.

Layout of surface mount resistors and green link "W2"

After the modification.

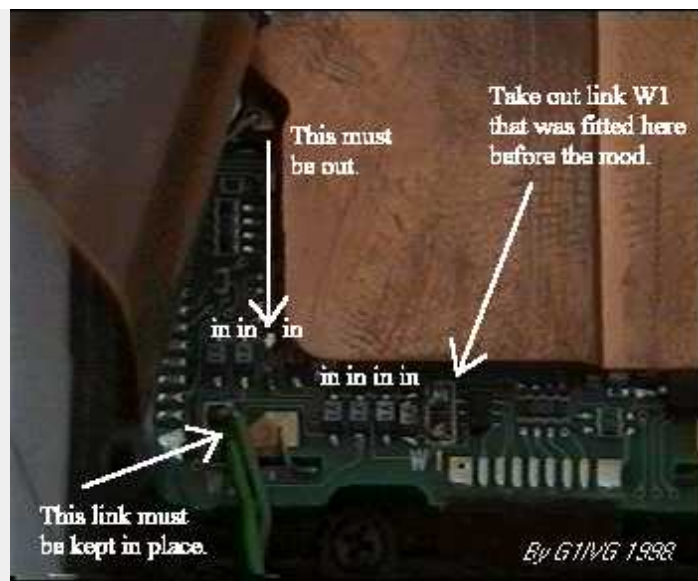

These modifications work 100% on my own Kenwood TH48E, the serial number of my radio is 60100848. However I can't guarantee they will work on your particular model. (The serial number can be found inside the battery compartment of the radio).

This modification is read 790 times.

[top of page](#)

23-04-2000

(TH-48) TH-28/48/78 Difficult battery insertion

Author: Kenwood Communication, inc.

Service Bulletin no. 1028 (29 June 1993)

Symptom:

Insertion of the battery into the transceiver is difficult or impossible due to problems with the release lever.

Corrective Action:

- A temporary cure is provide by loosening the two screws securing the holder, shifting the holder to the extreme left, then retightening the screws.
- A permanent fix is provide by replacing the holder and release level with new parts that have been deburred and modified to allow relocation of the release level.

Parts required:

Qty	Description	Kenwood Part No.	Circuit description
1	Holder	J19-1515-23	NA
1	Release lever	D10-0610-13	NA

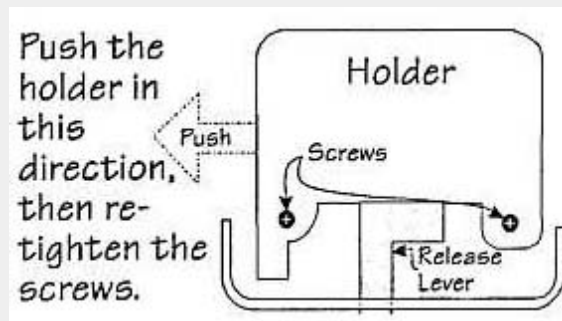

Time required for this modification is 30 minutes or less.

This modification is read 685 times.

[top of page](#)

23-04-2000

(TH-48) TH-28/48A/E CTCSS tone error

Author: Kenwood Communication, inc.

Service Bulletin no. 1037 (18 March 1994)

Symptom:

Several reports were received on early model TH-28/48's concerning an inability to access sub-audible tone controlled repeaters. This symptom only occurred when the repeater required the use of any of the following tones:

- 131.8 Hz
- 136.5 Hz
- 173.8 Hz

Corrective Action:

A microprocessor software error is responsible for this symptom. Replacing microprocessor IC6 on board X53-3400 (TH-28) or X53-3410 (TH-48) with the part listed below will correct this symptom.

Parts required:

Qty	Description	Old part No.	New Part No	Circuit desc.
1	Microprocessor	HD404629A73H	HD404729A79H	IC6

Caution: *This modification requires soldering equipment rated for CMOS type circuits. It also requires familiarity with surface mount soldering techniques. If you do not have the proper equipment or knowledge do not attempt this modification yourself. Seek qualified assistance.*

Time required for this modification is 30 minutes or less.

This modification is read 666 times.

[top of page](#)

23-04-2000

(TH-48) TH-48A Microprocessor change

Author: Kenwood Communication, inc.

Service Bulletin no. 1039 (10 February 1994)

Symptom:

Due to a recent rule change by the FCC it is no longer possible to supply transceivers, or provide replacement microprocessor that would allow a transceiver to receive in the 800 MHz band.

Corrective action:

The microprocessor program of IC5 has been modified to prevent 800 MHz band reception. Production has been changed beginning with serial number lot 510xxxx. Units produced after this point will not be capable of 800 MHz reception.

Parts required:

Qty	Description	Old part No.	New Part No
1	Microprocessor	HD404629A79H	HD404629B44H

Procedure:

When ordering a replacement microprocessor you will be supplied with the new version. Please make sure your customer understands the limitations of this new

This modification is read 683 times.

[top of page](#)

19-07-1998

(TH-75) TX across entire tuning range TH-75A

I have a couple of mods that you may or may not have. For the TH-75A MARS/CAP mod, removing D4 will allow TX across entire tuning range, except that actual TX range will be limited by tuning of the PLL.

For the TM-731A, there is a "Beyond MARS/CAP transmit Modification". It provides TX from 136 to 174 and 400 to 500 MHz. Again, actual TX range limited by PLL tuning. If you don't already have this and would like it, I'll send a copy if you furnish me your address. It involves cutting R25 on the control unit, and installing a jumper (diagram required to locate position), then two resets in a row.

I have tested these mods on my own rigs.
73 - Kevin, KD2SL @ KC3BQ

This modification is read 740 times.

[top of page](#)

19-07-1998

(TH-75) 9600 baud with the TH 75

I tested the following modification only for the 430 MHz part. Perhaps it works also on 2 meters if you try the modification on the 144 MHz IF-Unit.

For opening the TH 75 follow the instructions of the manual page 31 (installation of the TSU-Unit). After opening the handy, it is not necessary to disconnect any connectors between the front and rear part. All connections have to be done at the rear part.

-TX-

On the right side of the open handy is a connector (No. 201). The wires of this connector are leading to the lower board of the rear Part.

Disconnect this connector. Next remove the five screws holding the upper board. Now it is possible to lift this board for about 5 mm. On the lower side of the board are the solder pins of the connector which was opened before. Solder a thin wire to pin No 5. (Start counting at the antenna side of the TH 75).

This wire can be connected direct to the TX-Exit of your TNC, if this exit has A/C level only. If the TNC has also D/C level add a capacitor of about 4.5 to 6.8 uF.

-RX-

A little bit higher to the connector where the TX line was connected is the UHF - IF unit (X58-3610-00). It is a small additional board over the main board. You will find the IC TK10485M on this small board. Solder a wire to pin No 11, the first one the left side (Start counting again at the antenna Side). This pin is connected to a capacitor. In order to prevent the IC from being damaged, I recommend to do the soldering at this capacitor.

This wire can be connected direct to the TNC.

If you need for some reason the squelch of the TH 75 during 9K6 operation, add a resistor of 10 KOhms in the RX line.

These are all modifications necessary for 9K6, and now you can start closing the TH 75. If you do not install a cap of the DC IN Terminal, you have a fine little gap for the wires. But it is also possible to install an additional jack if the TSU-6 unit is not installed. The ground connection can be made via the speaker jack. The PTT line of the TNC should be connected to the MIC jack. The TH 75 is able to work with a TX-Delay of 150 - 170 ms (> T15) which is a good value for a modified PLL TRX.

This modification is read 626 times.

[top of page](#)

19-07-1998

(TH-75) TH-75A MARS/CAP modification

This modification will allow the TH-75A to transmit from 142 to 152 MHz and 420 to 450 MHz. Specifications are guaranteed for the Amateur Bands only. Through the transceiver will display 136 to 174 MHz and 335 to 512 MHz, the PLL circuit may not lock through the entire range.

Modification procedure

1. Disconnect the battery and antenna.
2. Remove the three case screws and two battery plate screws.
3. Lift the front panel from the body of the transceiver, but do not disconnect the two flex cables.
4. Cut the green jumper wire (W1) that is located to the left side of the CPU in the front panel assembly.
5. Assemble the transceiver by reversing steps 1-3.
6. Reset the CPU by holding the M key as the power is turned on.

I have tried it and it works.
Suresh Kagoo N9GSA

31-03-1999

(TH-75) TH-75E auf 9k6

de DL8FCL @ DKOMTV. #RPL.DEU.EU

Seit einigen Tagen benutze ich ein TH-75E mit recht gutem Erfolg für PR mit 9600 Baud. Der Umbau ist sehr einfach durchzuführen, und sollte jedem gelingen, der schon einmal einen Lötkolben in der Hand hatte.

Zuerst öffnet man das Gehäuse. Die zu entfernenden Schrauben kann man sich auf der letzten Seite der Bedienungsanleitung anschauen (Einbauanleitung für CTCSS unit TSU-6). Das Gerät soll selbstverständlich spannungsfrei sein.

Alle Anschlüsse werden an dem rückwärtigen Teil des Handies angelötet, aber man muß die Verbindungen zu dem vorderen Teil (der mit der Anzeige und Tastatur) nicht abtrennen.

--TX--

Auf der rechten Seite sieht man eine Steckverbindung (Nr. 201), deren Kabel nach unten in das Gehäuse verschwindet. Diese Verbindung muß man vorsichtig lösen. Nun löst man die 5 Schrauben, mit denen die gesamte Platine mit dem Rest verbunden ist. Jetzt kann man die Platine etwas nach oben biegen und sieht an der Unterseite die Lötstifte der Steckverbindung, die man zuerst gelöst hat.

An den Stift Nr. 5 von oben gezählt lötet man einen dünnen Draht. Diesen Draht kann man direkt mit dem TX-Ausgang des TNC verbinden.

--RX--

Ein Stück oberhalb der Steckverbindung, an der das TX-Signal eingespeist wird befindet sich die UHF IF Unit (X58-3610-00) als eine separate Platine, die auf die Hauptplatine aufgesetzt ist. Hier muß man den RX-Anschluß anlöten, da dies direkt an dem Diskriminator geschehen muß. Der richtige Punkt ist der Pin Nr.11 des IF-IC TK10485M. Dies ist der auf der linken Seite der 1. von oben gezählt. Von diesem Pin geht die Leiterbahn zu einem Kondensator. Ich habe den Draht an dessen Kontakt in Richtung IC angelötet, damit ich auf gar keinen Fall das IC beschädige.

Das war es, man kann das Gerät wieder zusammenbauen. Die Drähte kann man neben der Stromversorgungsbuchse nach außen führen, wenn man die Gummikappe wegläßt. Dort gibt es dann einen kleinen Spalt der sich dafür eignet. Man kann aber auch eine kleine Buchse in das Gerät direkt über dem Lautsprecher einbauen. Dies geht allerdings nur, wenn die CTCSS-Unit nicht eingebaut wurde. Die PTT-Leitung des TNC schließt man ganz einfach an die Mikrofonbuchse mit einem 3,5 mm Stereo-Stecker an. Dadurch ist auch das eingebaute Mikrofon abgeschaltet. Die Masseverbindung stellt man am Besten über die Lautsprecherbuchse her. Das hat den Vorteil, daß auch der Lautsprecher abgeschaltet ist. Er neigt sonst zu Knackgeräuschen, selbst wenn die NF ganz zuge dreht ist.

Ich habe noch keine Messungen (Augen-Diagnostik, BERT) durchführen können, aber praktische Tests auf DB0SPC haben zu vorzüglichen Resultaten geführt. Das TX-Delay habe ich auf 150 ms eingestellt, und bin in der Lage 5000 Bytes in weniger als 15 Sekunden auszulesen. Ich verwende einen TNC2H der Fa. SYMEK und habe bei der Einstellung des Sendefilters die besten Erfahrungen mit der Einstellung Nr. 1 gemacht. Die Einstellung des Hubes im TNC war auch nicht sehr schwierig, ich habe ganz einfach mit dem geringsten Hub angefangen und dann langsam aufgedreht, bis der Digi mir antwortete. Danach habe ich etwas oberhalb dieses Punktes hin und her gedreht, bis ich die besten Resultate erzielte.

Für eventuelle Fehler übernehme ich natürlich keine Haftung, bin ich aber gerne bereit Fragen zu beantworten. Ich wünsche viel Spaß beim Basteln und bei PR mit 9K6.

vy 73 es 55, Walter DL8FCL @ DKOMTV

20-04-2000

(TH-75) TH-75A No TX on VHF using a vehicle battery supply

Author: Trio-Kenwood Communication, inc.

Service Bulletin no. 957 (9-1-1990)

When the TH-75A is connected to a vehicle battery, ignition or alternator noise can be induced on the DC line. When the transceiver is in the automatic battery saver mode, the noise pulses overcharge C348 on the RF board causing it to short. The supply current opens L218 and the foil trace at this coil. To protect the transceiver, a Zener diode will be used to clamp the SBR line.

The Zener should be solder between the SBR side of L218 and the shielding case of L221 on the component side of the RF board (X53-3370-11) (A/3). The Service Manual disassembly instructions will be required to perform this modification.

Note: This modification has already been performed on models stating with serial number 007xxxx.

Required part:
22V Zener diode (UZP-22B)

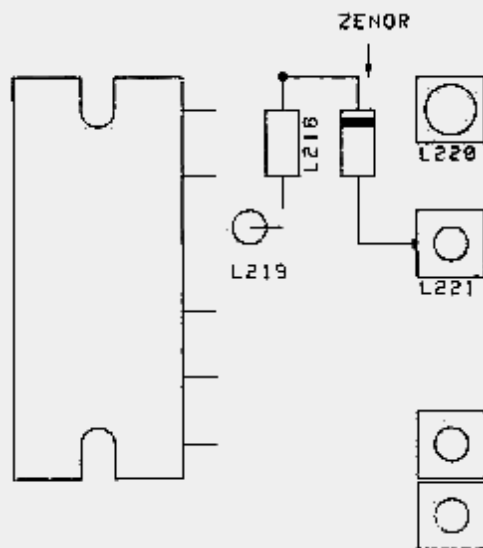

This is an optional change that is not covered under warranty.
Time to perform this modification is 1 hour or less.

This modification is read 608 times.

[top of page](#)

21-04-2000

(TH-75) TH-75A Intermittent memory loss

Author: Kenwood Communication, inc.

Service Bulletin no. 978 (8-8-1990)

Some TH-75A owners have reported that the transceiver intermittently loses its memory channel information after transmitting. Other users have reported symptoms such as key board lock up after transmitting. The following modification will re-configure the PTT input to the microprocessor to correct these conditions.

Required parts:

33 Kohm chip resistor	RK73GB1J333J
470 pF ceramic capacitor	CK45B1H471K
PTT tactile switch	S40-1415-05

1. Disconnect the battery and antenna.
2. Remove the three case screws and two battery plate screws. Figure 1.
3. Lift the front panel from the body of the transceiver and disconnect the two flex cables. To open the connectors push the tabs towards the flex cables and gently lift up. Figure 2.
4. Remove the 4 screws from the Control board inside the front panel. Figure 3.
5. Remove the 3 screws from the speaker mount. Figure 3.
6. Carefully lift the Control board, PTT switch assembly, speaker, and mic element from the front panel. Do not break any wires.
7. Lay the Control board on a soft cloth to avoid scratching the LCD.
8. Locate chip capacitor C2 on the Control board. Figure 4.
9. Replace C2 with a 33 Kohm chip resistor.
10. Remove the protective coating from the foil between pin 58 of the microprocessor and chip resistor R8. Presolder the exposed foil. Figure 5.
11. Size, cut, and bend the leads of the 470 pF ceramic capacitor and then install the component between pin 59 of the microprocessor and the ground side of the 33 Kohm chip resistor. Figure 6.
12. Remove the screw from the PTT switch assembly and then remove the rubber PTT cover from the board. Be careful not to lose the black plastic plate that fits inside the rubber cover.
13. Remove the PTT switch from the board.

14. Cut the tabs off the bottom of the new PTT switch to allow the switch to lay flush on the board. Figure 7.

15. Install the PTT switch.

16. Assemble the transceiver.

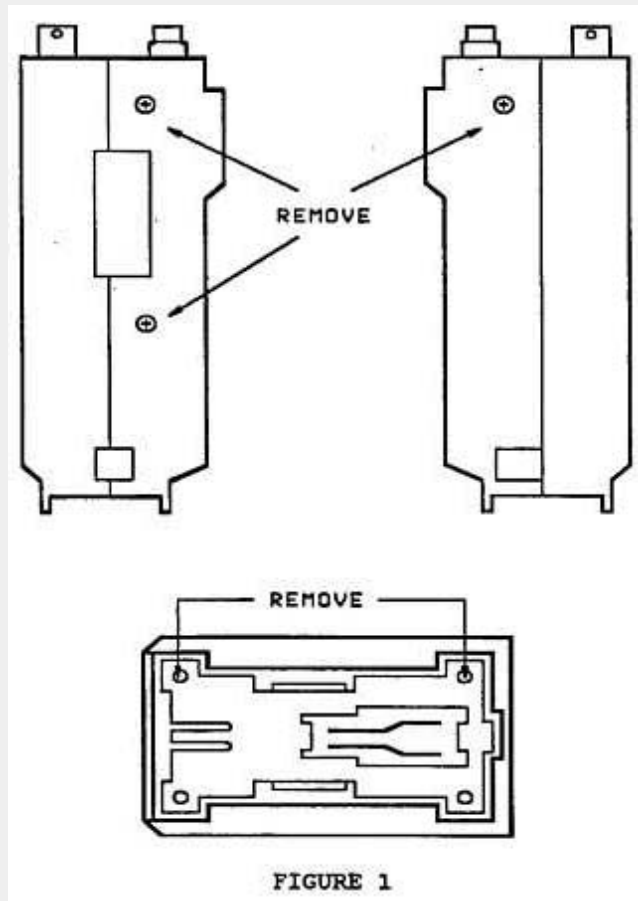

FIGURE 1

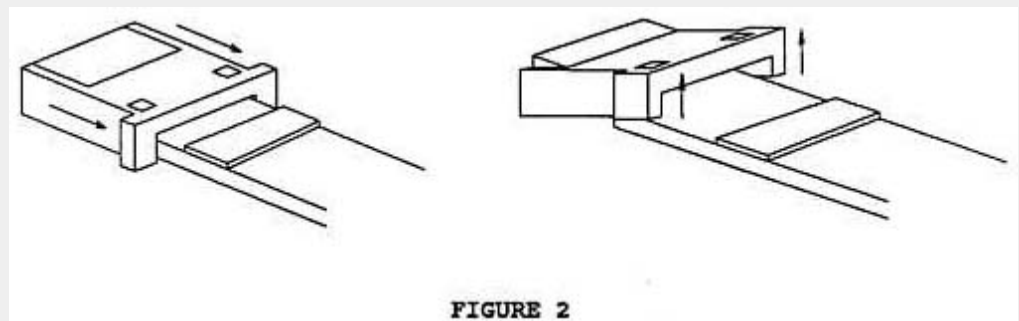

FIGURE 2

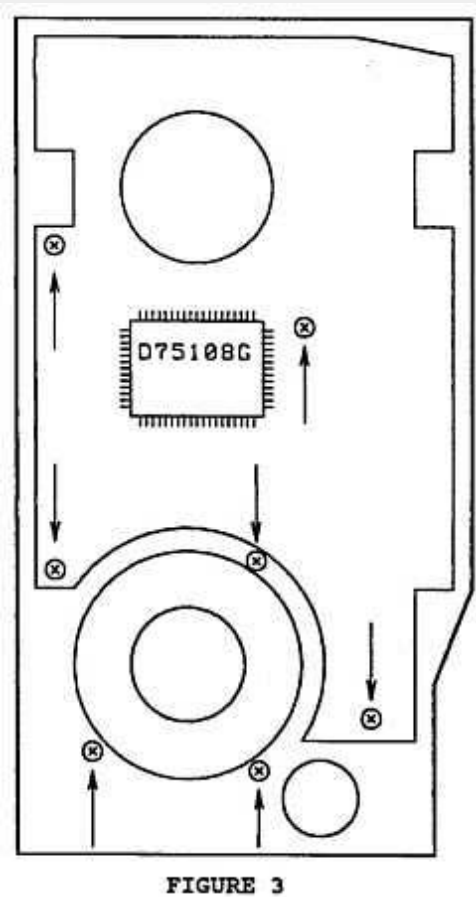

FIGURE 3

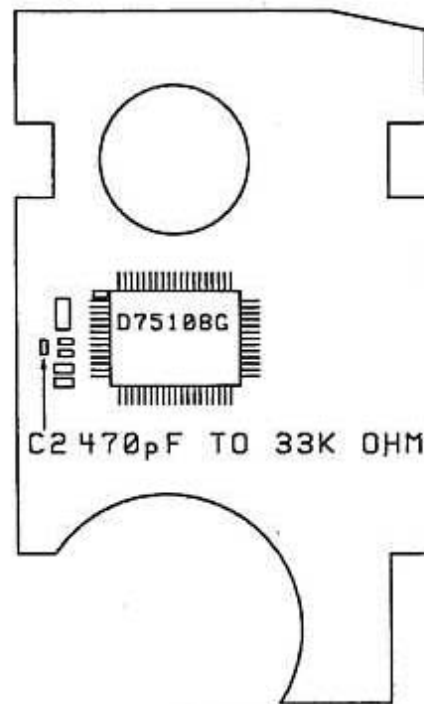

FIGURE 4

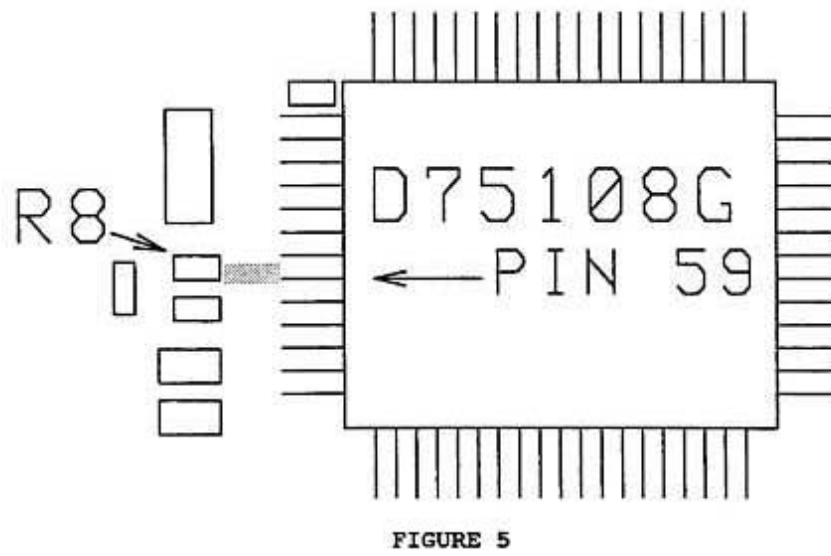

FIGURE 5

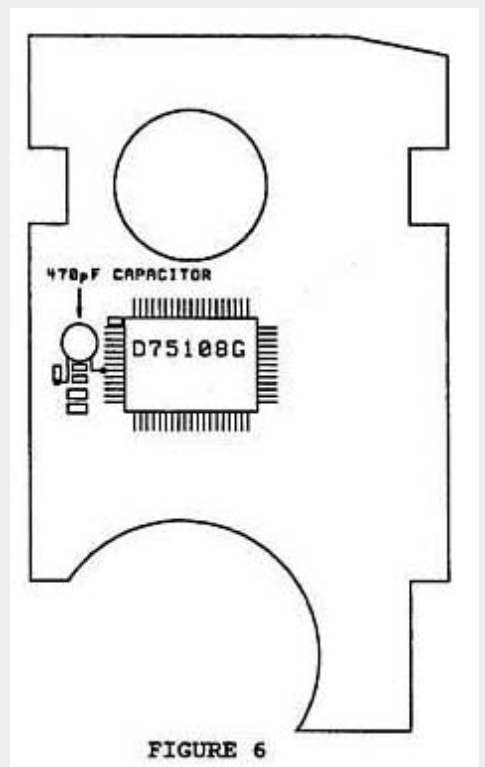

FIGURE 6

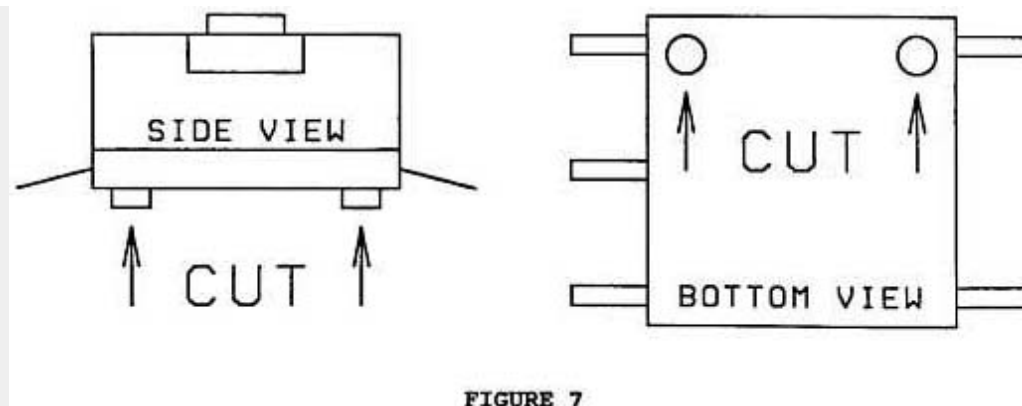

FIGURE 7

Time required to perform this modification is 1 hour or less.

This modification is read 612 times.

[top of page](#)

19-07-1998

(TH-77) Umbauanleitung fuer das TH77e von Kenwood fuer 9600 Baud

de DG1KWA @ DBOIZ. #NRW.DEU.EU

Hallo Oms,
hier ist eine Umbauanleitung fuer das TH77e von Kenwood.
Ich uebernehme keine Verantwortung fuer die Richtigkeit der Anleitung und auch nicht fuer Schaeden am Geraet die durch den Umbau entstehen.

Der Umbau spielt sich in der TX-RX Unit (X57-363X-XX:RFU) (B/3) ab.

1. Oeffnen des Geraetes (Spannungsfrei ?!!)
2. Jetzt sieht man auf die Steuerplatine des TH77e (Teil mit Tastatur) und auf die VHF TX-RX Unit. Jetzt geht man hin und loest vorsichtig die Schrauben der VHF Unit. Dann hebt man die VHF Unit vorsichtig ein bisschen hoch um die Verbindung mit der UHF Unit zu trennen. Jetzt kann man durch leichtes ziehen die VHF Unit von dem Stecker, der am Flachbandkabel ist, trennen. Die Schrauben und die Unit beiseite legen.
Jetzt kann man das Flachbandkabel ganz abziehen (Vorsicht, das Zeug ist empfindlich). Dann loest man die Schrauben des Bleches, welches ueber der UHF-Unit liegt. Als naechstes, nach Entfernen des Bleches, kann man die UHF Unit loesen (Achtung: Draht von der BNC-Buchse muss abgeloetet werden) und herausnehmen.
3. Jetzt loetet man einen Draht an Pin 9 des IC 202 (MC 3372D) an (unter der Platine).
An diesem Pin steht das Signal vom Diskriminator zur Verfuegung. Hier wird also der Eingang des Modems angeschlossen (NFin oder DEMOD).
4. Zusammenbau des TH77e bis auf die Metallschiene fuer den Akku.
5. Jetzt loetet man einen Draht an den 21 poligen Steckverbinder 201 Pin 2 an. Hier wird die Modulationsspannung angeschlossen. Die Zaehlweise ist von rechts nach links, wenn der TRX so liegt, dass die Frontplatte oben ist.

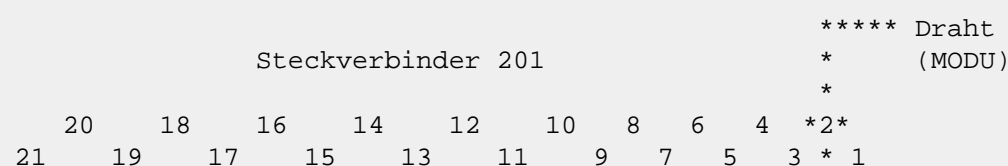

Ueber dem Steckverbinder 201 liegt der Steckverbinder fuer die VHF-Unit.

Damit sind die Umbauten am Geraet abgeschlossen.

Man sollte sich aber Gedanken machen, wo man die beiden Draehte herausfuehrt. Ich habe den Schieber von der Akkuverriegelung weggelassen und dort die beiden Draehte herausgezogen.

6. Jetzt kann man das G3RUH-Modem bzw. das TNC anschliessen. Als erstes nimmt man den Draht fuer den Empfang. Man stellt das TH77e auf ein 9600 PR-QRG. Sind die Frames einwandfrei zu dekodieren hat man diesen Teil schon einmal richtig gemacht (evtl. kann eine Widerstandsanpassung notwendig sein, ein 10kOhm Spannungsteiler sollte reichen).
7. Als naechstes kann man die Sendeleitung anschliessen. Die PTT wird ueber die vorhandenen Buchsen angeschlossen und an den verbliebenen Draht den Ausgang des G3RUH. Mit Hilfe eines Kontrollempfaengers kann man die Staerke der Modulation einstellen. Ist auch dieser Teil erledigt kann man versuchen den Digi zu connecten. Ich habe ein Txdelay von 16 benutzt. Wenn der Connect kommt, hat man es geschafft.
Das Lesen einer grossen Rubrik muss einwandfrei moeglich sein.

Das TH77e kann weiter ohne Probleme fuer FM benutzt werden, weil der Mikrofonverstaerker nicht abgetrennt wurde. Auch braucht man beim 9600 Baud Betrieb keine Stoerungen befuerchten, weil durch das Stecken des 3,5mm- Steckers fuer die PTT das interne Mirko abgeschaltet wird.

Ein von mir durchgefuehrter BERT (Bit Error Test) ergab keine besondere 9600 Baud-Tauglichkeit, aber es geht. Das Txdelay sollte man so niedrig wie nur moeglich einstellen, ich denke 10 wird noch drin sein.

Viel Spass mit 9600 Baud.

Nachtrag:

Angeregt zum Umbau und Schreiben dieser Anleitung wurde ich von DL1KBB.

Er hat sein TH77e als erstes umgebaut und mir eine kleine Umbauanleitung zukommen lassen. Ich danke ihm dafür noch einmal.

vy 73/55 de DG1KWA / Andreas @DB0IZ

This modification is read 868 times.

[top of page](#)

19-07-1998

(TH-77) Expanded RX/TX for TH-77A

From the factory, it can receive 138-174MHz and seems to do it quite well with the supplied rubber duck antenna. It can also receive 438-450MHz and, likewise, does this quite well too! One very interesting feature of the TH77A is that it can do *DUAL* UHF receive! To do this it uses the VHF receive section and you have less sensitivity, but I really haven't noticed much signal degradation at all.

NOW! On to the *EXTRA* capabilities (there are other BASIC functions that I didn't mention, those were just the highlights). After making a few modifications to this radio, you can get it to do the regular stuff that the IC24AT will do, such as AM aircraft, expanded UHF (400-512 depending on PLL lock) and 800-950 (again, depending on PLL lock) in addition to cross band repeat.

HOW DO YOU DO THIS!?

Easy (if you've got a steady hand for removing a chip resistor!).

Open it up. There are 3 screws visible on the outside and 4 more underneath the battery pack. Unlike most radios, this one doesn't have a spring for the battery release switch. It gets spring action from the metal plate that you will remove when you take out the four screws.

Anyway, the area you will be working in is on the control board which is fixed to the front section of the radio. In particular, look for the yellow electrolytic capacitor (its yellow in mine) that is at the dead center of the board (there are two IC's, one above this and 1 below this). You will have to remove the electrolytic capacitor (C124) and set it aside for a few minutes. You will be putting it back afterward. The reason for removing this is so that you can remove a chip resistor that is underneath it. To avoid tearing the flex board foil traces, do not bend the leads of the capacitor.

There is a green wire that is connected to one side of this capacitor. If you disconnect one side of this green wire, you will get RX from 400-512 (PLL lock depends on the radio, but you can DIAL from 400 to 512). Orient the radio so that the volume controls and BNC are at 12 O'Clock on your table (farthest from you) and the bottom (where the battery connects) is at 6 O'Clock. The area where you removed the capacitor, you will see a blank space where there could have been a chip resistor followed by two chip resistors side-by-side and in the next row below that, you will see 3 more that are side-by-side.

There is one to the left of these two rows that is kind of off center. Now, there are three ways to configure this radio at this point:

1. With one side of the green wire pulled, you will have 136-174 RX, 400-512 RX. If that's all you want, you are done.
2. By removing the rightmost chip resistor (R129), in addition to keeping one side of the green wire disconnected, you will have 136-174 RX, 400-512 RX, 118-136 AM RX, 800-950 RX.
3. By removing both of the chip resistors, in addition to putting the green wire BACK where it belongs, you will have 136-174 RX/TX, 400-512 RX/TX, 118-136 AM RX and 800-950 RX.

All three of these options include, of course, putting the electrolytic capacitor back in place afterwards.

NOTE! ONCE YOU START DOING THIS STUFF, YOUR MEMORIES AND POWER ON SWITCH CONFIGURATIONS WILL ALL BE LOST! MAKE A NOTE OF HOW YOU ARE SETUP BEFORE YOU BEGIN!

Layout shown with electrolytic capacitor C124 removed

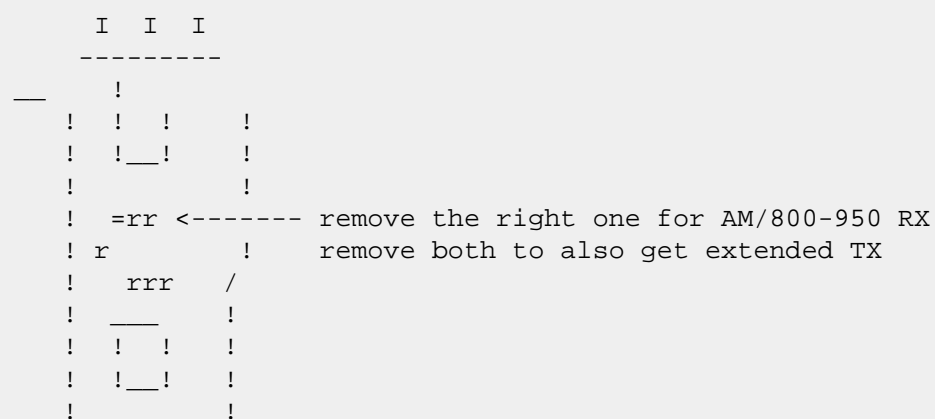

Layout shown with electrolytic capacitor C124 removed

The best way to do this is to heat up both sides of the resistor and More? y

push it out of the way with something small. At least this was the best way for me! Once it's out, put the capacitor back in place and close it up. (Put the green wire back also, if you are making the out of band TX mod too!)

This modification is read 1187 times.

[top of page](#)

19-07-1998

(TH-77) receive AM aircraft

To receive AM aircraft, get the VHF side in the main band and hit the ENT key twice to go to the VFO. Once you are in the VFO, hit the UxU key twice. Once for dual UHF receive and the 2nd time for AM (118-136).

To receive 800-950, get the UHF side in the main band and hit the ENT key twice to go to the VFO. Once you are in the VFO, hit the UxU key once.

This modification is read 958 times.

[top of page](#)

19-07-1998

(TH-77) Crossband repeat

To enable crossband repeat, hold down the SUB BAND UP ARROW key while turning on power. To disable, do the same thing again. Kenwood says that both bands can contain shift information but only one band can include an encode/decode tone.

This modification is read 873 times.

[top of page](#)

19-07-1998

(TH-77) TH-77A PLL Unlock Override Mod

After receiving the service manual and completing the 'chip resistor' mods for my TH-77A, I have another mod to share.

Some of you may have been annoyed at the constant beeping when the PLL is not in lock even though you are able to listen at a given frequency. Yet adjusting the VFOs is quite a task. They are both shielded and soldered to the board. There is no external access to the VFO can for any adjustments. In fact, there are no adjustable coils or trimmers in the VFO!

I have found my VFO range to be quite adequate, however, just the beeps were bothersome. But not anymore! Here is a simple mod which defeats the PLL unlock signal from reaching the CPU. There are some pros and cons associated with this however :

*** Pro ***

- The receiver never beeps anymore even though you have a marginal battery (which affects VFO/PLL lock) and are capable of receiving the given freq.
- Since the receiver no longer beeps, you can dial thru frequencies quickly without waiting a full half-second for the display to change each time the radio beeps.
- When an out of band transmit is attempted, the transmitter no longer shuts off after 1 second due to marginal PLL lock.

*** Con ***

- You will not know, w/o some sort of monitor receiver, if you are xmitting when far out of band. That is because the meter will show full scale even if the PLL is out of lock and not transmitting on frequency.
- At the extreme edges of PLL lock, the VFO will vary widely in 'sling-shot' fashion until lock occurs (sometimes after 1 full second). This means your transmitted signal may be all over the band until lock occurs.

If you feel the pro outweigh the con, you may be interested in performing this mod. Be aware, that YOU are responsible for the purity, accuracy and stability of any transmissions you make from your TH-77A. THIS MODIFICATION WILL DEFINITELY VOID YOUR WARRANTY AND PERMIT OUT-OF-BAND TRANSMISSIONS OF QUESTIONABLE QUALITY AT CERTAIN FREQUENCIES. You should not perform any out-of-band transmissions with this modification in place. THE INTENT OF THIS MODIFICATION IS TO ALLEVIATE PLL LOCK PROBLEMS IN *RECEIVE* ONLY!!

Now that the legalities are done, on with the mod. (Because I am too lazy to make drawings and directions, I have copied the one below from an earlier mod posted about the TH-77A - with the required changes)

MODIFICATIONS FOR IGNORING PLL UNLOCK

Open up the radio. There are 3 screws visible on the outside and 4 more underneath where the battery pack goes.

Locate the control board which is fixed to the front section of the radio. Look for the 100uF electrolytic capacitor (it's yellow in mine) that is at the dead center of the board (there are two IC's, one above it and one below it). It is most likely a PC mount (NOT an axial type capacitor with one lead on each end) capacitor lying on its side. You will be attaching a single wire to the negative lead of this 100uF capacitor. To avoid tearing the flex board foil traces, do not bend the leads of the capacitor.

Orient the radio so that the volume controls and BNC are at 12 O'Clock on your table (farthest from you) and the bottom (where the battery connects) is at 6 O'Clock (nearest you). Looking at the lower IC which should be a rectangular NEC 75116GF-67x-3BE, there are 19 pins running along the lower edge closest to where the battery connects. There should be an embossed dimple or dot on the lower left corner of the IC to indicate pin 1. As you count from the left, locate pins 12 and 13. These two pins are defined as follows:

pin 12 - VHF Unlock Input
pin 13 - UHF Unlock Input

Normally these pins are low to indicate the PLL is in lock. When you change frequency, they *momentarily* go high (at worst about 250 milliseconds) while the VFO comes into lock. If the pulse stays high for longer than this period the CPU interprets this as a marginal lock and begins to beep. What we are going to do is permanently ground these pins (or just one if you prefer) to trick the CPU into thinking the PLL's are always in lock. There is no need to worry about shorting the output of the PLL's unlock pin since there is a 4.7K resistor between it and the CPU pins.

The best way to do this is with some fine gauge wire (I used #30 wire-wrap). If you are going to disable both VHF and UHF unlock, you can just short pins 12 and 13 together. Then connect the other end of your wire to the negative lead of that 100uF capacitor you found earlier. Here is a little pictorial to clear things up:

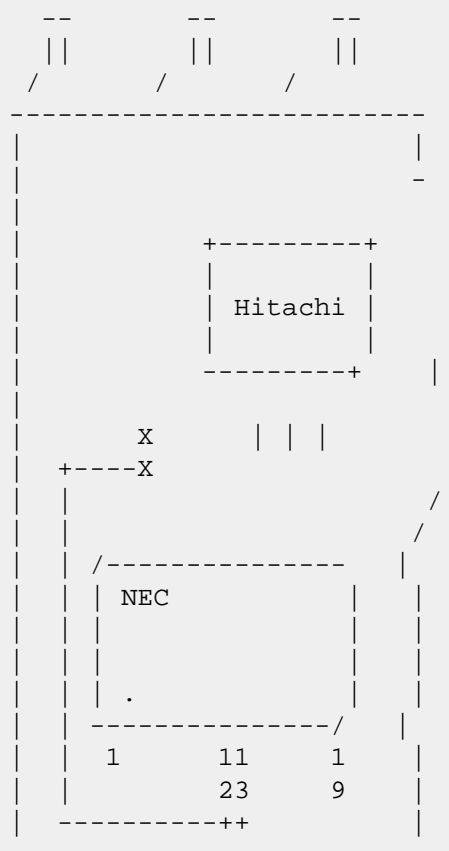

The X's are where the 100uF capacitor is soldered to the board. Just tack your wire onto the capacitor's negative lead or onto it's circuit pad.

That's it! Of course this mod does nothing for you unless you have already completed the 'chip resistor' mods for allowing out of band reception. Try dialing up a frequency that used to beep every time your rotated the tuning knob (most likely a 800 Mhz frequency). It should no longer beep. In fact you could probably dialup 512 Mhz and key up the transmitter and get a full scale reading. But remember, your VFO probably won't get that high anyway, and you are most likely transmitting at some frequency where the VFO tops out at and begins to ripple in frequency as it fruitlessly attempts to lock.

SOME PERSONAL OBSERVATIONS

After retuning my UHF front end, I can now listen to some public service frequencies in peace, without the annoying beep. However, keep in mind that if you are listening to something at 490 Mhz, your VFO is running way down at about 432 Mhz. I think a number of people feel that if they can receive at a given frequency (even marginally) they should be able to key up solidly.

If you like living dangerously and transmitting out-of-band please be considerate and know the limitations of your TH-77A. Although being able to transmit out-of-band with this non FCC type-accepted is risky enough, I must reiterate that YOU must now be watchful about your TH-77A operation. With this mod in place, the TH-77A will NO LONGER protect you from transmitting with a marginal output. The transmitter will key up whenever you ask it to, even while the PLL is still hunting for lock. However, I'm sure most of you will perform this mod simply to make receiving out-of-band more enjoyable as I've found.

Well, I hope this information helps you get more from you new toy! Happy monitoring!

Clifford K. Yamamoto - KA6JRG Email: cyamamot@kilroy.jpl.nasa.gov

19-07-1998**(TH-77) Pushing the TH-77A UHF receiver higher in frequency**

Have you ever wondered if the TH-77A UHF receiver could be "squeezed" out further beyond the end of the amateur band at 450MHz? If you've already made the chip resistor mods that allow you to go beyond 450MHz then you're half way there! When I made the chip resistor mod I was hoping to hear activity up in the 480MHz area, and hopefully in the 506MHz area also. Well, the 480MHz region was quite noisy and I always had to find a hot spot to listen. Needless to say that the 506MHz region was non-existent. (NOTE: Even after these adjustments the 506MHz region was not very good in my radio. However, I have seen some radios that work rather well at 506MHz without this adjustment!). So, I decided to "take a look" inside and see if there was anything in there that I could "turn" to improve reception. It turns out that there is a bandpass filter in the front end of the radio that can be re-tuned to your liking.

Finding the bandpass filter on the schematic

Grab your schematic diagram entitled, "TH-77A/77E Schematic Diagram" and flip it over to the back side. Locate the antenna input at the upper right of the schematic. Follow the trace from the antenna to the left towards the "UHF Pwr Amp Unit". Just before this unit follow the trace down through L207, Q207 and then stop at L226 just before Q206. If you look at the "TH-77A/77E Block Diagram" and follow the same flow you will see the bandpass filter between Q207 and Q206.

Finding the bandpass filter in the radio

It's time to open the radio up! Since you've already made the chip resistor mods we'll assume that you know how to carefully open up the radio. Once open, you'll be working with the front half of the radio (opposite that where you made the chip resistor mods). This half of the radio is where all the RF is done (both TX and RX). There is a VHF board and a UHF board. Unfortunately, the VHF board is on top so it must be removed to gain access to the UHF board. Observe the screws that are holding down the board. Carefully remove them and put them in a place so that you know which holes they go back into. Once the screws are removed you'll have to "work" the board out of the header connector towards the bottom of the radio. It goes without saying, but BE CAREFUL!! Once you've removed the board you'll see a metal plate that separates this VHF board from the UHF board. Fortunately, Kenwood made three holes in the metal plate to access the bandpass filter that you've just found!

Tuning the bandpass filter

I was a bit anxious to "play" with the bandpass filter so when I did mine it was around 2am at home so I didn't have a RF generator to do it properly. I would suggest that you use a RF generator, if possible, so that you can keep track of the sensitivity of the receiver in the amateur band. Without a generator you'll have to tune to a high frequency that you are interested in receiving (hoping that the channel is active) and then tweak the bandpass filter to improve reception. Then you'll have to switch back to the amateur band and key up a repeater to see what the sensitivity is like.

Since I did not use a RF generator I can only give my view of how it should be done. I would connect the RF generator to the radio and dial up a frequency that I am interested in being able to receive. Then, start with the generator output very low (modulated with a 1KHz tone at 2 or 3KHz deviation) and bring it up slowly until you begin to hear the tone in the receiver. At this point, adjust the bandpass filter a little at a time, making note of where the coil screw is before you begin to move it so you can go back if things are not working out. I wouldn't adjust the bandpass filter to get too much improvement because any improvement at this frequency means a degradation in the amateur band. You don't want to be too far away from the 0.18uV sensitivity specification for the amateur band. You'll have to play with it to find the spot where the tradeoffs are acceptable. One thing I can't remember, though, is whether you have to put the VHF board back in each time you make an adjustment so the radio will work (in order to listen to the speaker). That may have been necessary to "transmit" since in my case I had to kerchunk a UHF repeater to test my sensitivity in the amateur band.

I was interested in getting the 506MHz region to work better, but I had to give up on that. It is much better than it was without making these adjustments, but I still need to be in the primary coverage area for the 506MHz transmitter to hear it "ok".

Once you're satisfied with the performance, put the VHF board back in, screw everything down and close the radio up. Another good test of how your radio is performing in the amateur band is to switch the VHF side into UHF operation. Dial up your favorite UHF repeater on both the "VHF doing UHF" side and the normal UHF side. Then kerchunk the repeater and do a quick comparison of the S-Meter's. (This might be a good comparison to try before hand also to get an idea of how the two compare before making these adjustments).

That's about it! Enjoy the extra capabilities of your radio! Now, since we can hear all these other frequencies i'm anxious to hear from anyone who can find out how to modify the radio to get more memory channels, HI HI!

Gerald J. Walsh
gwalsh@kilroy.jpl.nasa.gov
KB6OOC@W6VIO. #SOCA.CA.USA.NA

(TH-77) TH-77A Memory loss with low battery pack

Author: Kenwood Communication, inc.

Service Bulletin no. 981 (6-2-1991)

Some of the TH-75A handhells in serial number range S/N 206xxxxx intermittently lose memory when the NiCad battery pack becomes discharged. The following modification will correct this condition. The TH-77A transceivers in serial number range S/N 207xxxxx and above will incorporate a change in the microprocessor to prevent this condition.

This modification requires the ability to desolder a surface mounted microminiature chip resistor from a flex PC board. If you do not remove microminiature chip resistors from flex PC boards on a regular basis, DO NOT attempt this modification.

Be sure to remove the battery terminal plate in step 2. If the battery terminal plate is left on the transceiver (only the top 2 screws removed) the flex cable for the CTCSS unit can be damaged.

Required parts:

33 Kohm chip resistor, RK73GB1J333J

1. Disconnect the battery and antenna.
2. Remove the 4 screws from the battery terminal plate and then remove the plate. Figure 1.
3. Remove three case screws from the transceiver. Figure 1.
4. Carefully open the transceiver. Be careful not to break the flex cable that connects the front panel Control board to the body of the transceiver.
5. Locate chip resistor R301 on the Control board inside the front panel of the transceiver. Figure 2.
6. Check for a solder bridge between the foil trace connected to the bottom of..... The rest of the composing is missing, please [mail me](#) if you have this.
7. Remove chip resistor R301.

Recommended method: Use a hot air jet system to melt the solder on both sides of the resistors. When the solder is molten, remove the chip resistor with a pair of tweezers.

Optional method: Use a wedge shaped soldering iron tip to melt the solder on both sides of the resistor at one time. As the solder melts, the chip resistor will lift from the board and stick to the soldering tip. Do not attempt to pry the chip resistor from the board. Figure 3.

8. Install a 33 Kohm chip resistor in place of R301. Do not re-connect the solder bridge removed in step 6.
9. Assemble the transceiver. Make sure the CTCSS board is positioned correctly so the flex cable is not stressed. Do not force the radio together.

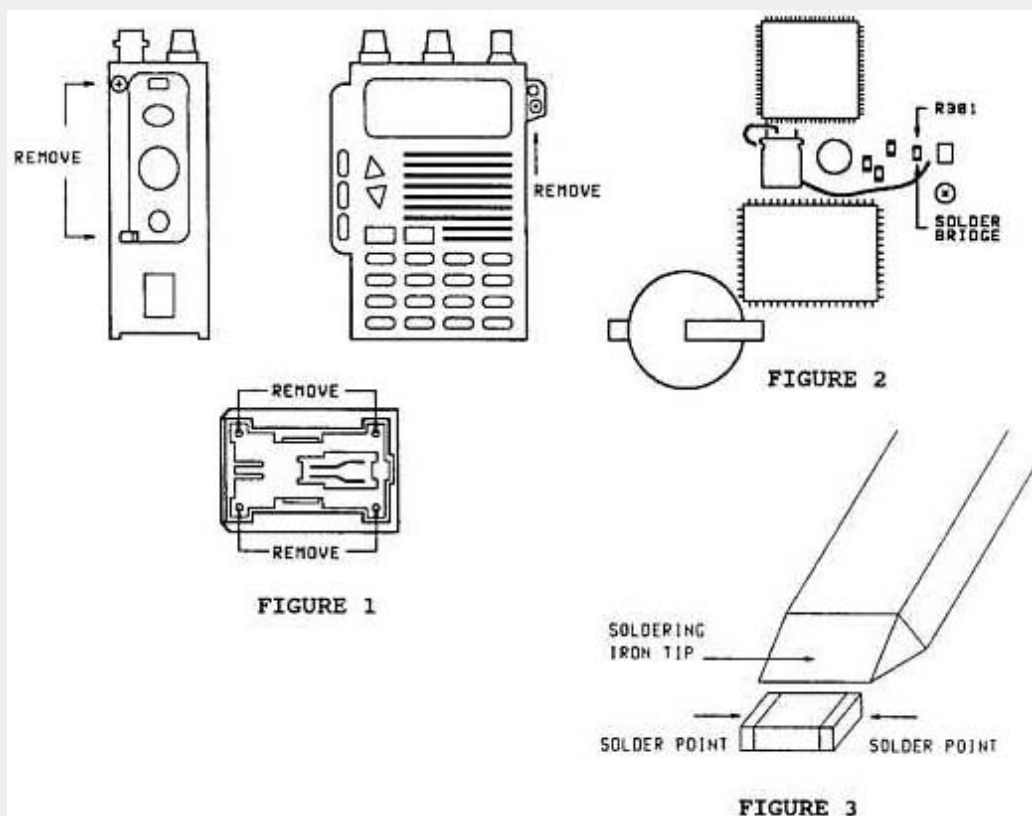

Time required to perform this modification is 1 hour or less.

19-07-1998**(TH-78) Basics of modifying the Kenwood TH-78a**

To open the radio, follow the instructions on page 64 of the manual. (Unscrew four screws and break apart the radio halves.) The two TX/RX busy indicators (LEDs) have rubber seals placed over them. These have a tendency to fall off when opening or closing the radio.

All position references in this document assume that you are looking at the CPU board with the rotary encoders and TX/RX busy indicators at the top.

If you have installed the ME-1 EEPROM, I recommend that you temporarily remove it to facilitate access to the diodes.

You'll see a brass shield about one centimeter square covering the processor chip and the surface-mount diodes on the back half of the radio.

De-solder the shield's four corners and remove it. (I used a right angle surgical tweezers in conjunction with the pin-point soldering iron to lift the brass shield.)

Uncovered are the processor (which we ignore) and six surface-mount diodes, numbered sequentially from one through six (D1 - D6), top to bottom. These are about one millimeter wide; remember the note about skill and finesse.

New model radios also have two large loops of green wire, numbered one through two (W1 - W2), bottom to top.

You'll need a pinpoint-tip soldering iron and some braid to wick away the solder before you lift out the diode. Alternatively, Rich Garcia (n2czf@wt3v.nj.usa) suggests leaving the diode in place. "I found if you BRIEFLY touch the iron to the right side lead while gently pulling up on the SMC diode it should completely come off without needing to apply heat to the other side and further risk board damage."

After you perform some or all of the mods listed below, replace the brass shield and re-assemble the radio. Then reset the processor (as documented) and re-enter any frequencies into memory.

19-07-1998**(TH-78) Potential case design flaw**

From wb1e@k1rqg.me.usa.na (which no longer exists):

In the course of performing mods on my Kenwood TH-78a dual band handheld, I've discovered a potential flaw in the case design. While handling my walkie one day (after the mods were done), the display went blank and I could not turn the radio back on. With the radio split in half again, I could turn the radio back on but discovered all the memories were erased. The cause turned out to be some component pins on the front face coming in contact with the square bodies of the two volume/channel/squelch switches, when the case is screwed back together snugly. I placed small strips of electrical tape on the sides of the switches to insulate, and reassembled; problem solved. Now I have to reprogram the darn thing....

molson@bml4380.cpg.cdc.com (Mark Olson) said:

There is a warning on some of the rig mod bulletin boards about this. The problem is that pins on the back side of the PCB that is mounted on the front half of the TH78 can come into contact with the volume control housings mounted on the PCB on the other half of the unit. My radio had this problem until I put electrical tape across these housings. Symptoms were: Display blanking momentarily and the unit power cycling, sometimes causing memory erase, when pressure was applied to the front of the unit or to the volume controls. I originally thought that it was a loose battery connection...

Open up the radio and you will see what I mean... Believe me, the fix is simple and it works.

19-07-1998**(TH-78) C-17 design flaw**

William_A._Kirsanoff@smtpgty.anatcp.rockwell.COM said:

"The 78A WILL lose C-17 on the control board if dropped, period. This causes loss on receive audio on the left-hand side of the radio. The solder pads for that cap are not big enough. If you find the need to replace C-17, use a gap-fill cyanoacrylate glue like Zap-A-Gap (tm) to increase the device footprint. I have learned the hard way. Otherwise, I have found it to be a fine radio. My only problems have been related to the C-17 issue and attempts to rectify it. Had I been given the above advice, it would have been a one-time only issue. As it is, I took out one of the microprocessors yesterday looking for a bad solder joint that was induced by my attempt to solve the C-17 problem (sigh). This radio gets a lot of use and a lot of travel. C-17 is the only thing that I have broken with the case closed.

This modification is read 1281 times.

[top of page](#)

19-07-1998

(TH-78) Mutually exclusive mods

Some of these mods are reputed to be mutually exclusive. You must choose one of the following levels of performance:

- The "beyond MARS" mod - gets you the widest tx/rx
- The "MARS/CAPS" mod - halfway there
- The "extended receive" mod - more of a good thing

plus

The "cross-band repeat" mod - a repeater that weighs almost nothing
There is no mods that manipulate diodes D1 or D2 (I've seen it suggested elsewhere that this is toggles the USA/Europe-ness).

Brendan_Hoar@notes.pw.com suggests:

"I think removal of D1 causes "Forced Channelized Mode", at least on the "new" radios. If you put both VHF and UHF memories into a TH78A without D1 and power on, you are stuck in channel mode until you do a full memory reset. Remember, you can't add frequencies or do any tuning in channel mode.

If you think about it, you'll want to be very careful not to let D1's circuit become an open circuit.

This modification is read 1335 times.

[top of page](#)

19-07-1998

(TH-78) The beyond MARS mod

This mod provides the widest possible range of tx/rx. The mother of all TH-78a mods.

To mod (early model): remove diode D5 only.

To mod (late model): remove diode D3 and cut wire W1. D5 has priority over D3, so if you've already made the mods for the old model (which included the removal of D5) you must resolder D3 into D5.

Yields RX 50-179.995, TX 136-179.995, RX 300-399.995, RX 400-511.995, TX 400-511.995, RX 800-999.995.

To use: buttons operate the same way as described in the "extended receive" mod, except that you can transmit on a much wider range.

NOTE TO ALL: I haven't been able to verify the actual operation of my radio on all these freqs. Kenwood talks about the difference between the "dialable" range and the operating range. I'd like to come up with a chart for each level of mod that combines the above and the two following offerings. Help me, please.

* * * * *

Left VFO	Right VFO
50.000-85.2x (with beep)	50.000-110.xxx (with beep)
85.2x-179.995	110.xxx-179.995
300.00-399.975	
400.000-511.9875	400.000-511.9875
	800.00-999.9875

* * * * *

Receive		Transmit
-----		-----
50-135.995 (AM)	VHF	(NA)
136-179.995	"	136-179.995
300-399 (AM & FM)	"	(NA)

400-511.99	SUB-UHF	400-511.99
400-511.99	UHF	400-511.99
900-949.9875	"	(NA)
50-179.995 (FM)	SUB-VHF	136-179.995

This modification is read 1389 times.

[top of page](#)

19-07-1998

(TH-78) The CAP/MARS mod

This doesn't cover as much room as the beyond MARS mod does, but may be more appropriate for those who use the CAP or MARS frequencies.

To mod (both early and late models): remove D6 only.

Yields RX 118-173.995, TX 142-151.995, RX 400-511.995, TX 425-454.995.

This modification is read 1269 times.

[top of page](#)

19-07-1998

(TH-78) The extended receive mod

This is the mod that's usually given to hams to pacify them (the beyond MARS mod is closely guarded).

To mod (both early and late models): remove diode D5.

To use: press "F" for one second and then pressing the Band button will switch the UHF VFO to a 800-999.995 MHz band and the VHF VFO to a 300-399.995 MHz band. The regular VHF VFO can now receive down to 50 Mhz.

This modification is read 1436 times.

[top of page](#)

19-07-1998

(TH-78) The cross-band repeat mod

To mod: remove diode D4.

To use: press "F" for one second, then "0". Repeat to disable. The MHz dot will flash when in repeater mode.

Date: 29-12-2001

User comment

From: [DO1MOS](#)

Subject: Cross-Band-Repeater Operation with bad audio?

Hello everyone,
my problem is the bad audio on Crossband-Repeater operation. By using this mod, the audio sounds like a tin. I use the TH-78E. Can U help me?

Thanks, we will meet us at HAMRADIO in Germany

Sascha, do1mos

This modification is read 1324 times.

[top of page](#)

19-07-1998

(TH-78) Toggle SHIFT button function

Press SHIFT during power-up This is described in the manual, but the documentation is not complete. The TH-78A can operate in two modes: In SPLIT mode, non-standard offsets (i.e. split frequencies) are supported, but the default offset is not programmable. In SHIFT mode, non-standard offsets are not allowed, but the default offset is programmable. To select the default offset, press F for 1 second, then SHIFT. See p. 30 of the manual for details on changing the default offset.

This modification is read 1235 times.

[top of page](#)

19-07-1998

(TH-78) Toggle CALL button function

Press CALL during power-up. The CALL button can operate in one of two modes. In the default mode (CALLSW), it switches between the call channel and the last memory channel (if in memory recall mode) or last frequency (if in VFO mode). After toggling the CALL button functionality (VMC), it will switch from the VFO to the last memory channel and then back to the CALL channel.

This modification is read 1183 times.

[top of page](#)

19-07-1998

(TH-78) Observations on post-mod performance

Rich Garcia (n2czf@wt3v.nj.usa) observes "all original functions have maintained the same which is great. Aircraft band which was accessible before the mod remains with the same characteristics. It seems that VHF-High band has improved a bit on sensitivity where it was dead as a dog before the mod (above 155.000MHz) but the 162.000 MHz band where weather radio is is still a bit deaf for reception at any distance but about 20 Miles. This depends on your (or my) terrain and transmitter output power.

"On UHF all public safety frequencies up to about 500 MHz seem to come in well but sensitivity greatly drops from there (we really can't ask for more).

Frequencies can be programmed in up to the 920MHz ham band but I have no way of measuring sensitivity. 800MHz works but the signals are very weak, you must be near the transmitter for reception. Assuming you are in the town or city where the transmissions originate it should work.

"Transmit is enabled up to and incl. 500MHz but after testing this on a frequency counter I find that a signal is only generated to about 490 MHz, even though the trans. LED shows output in the higher frequencies.

"Crossband repeat seems to work fine but the audio is unacceptable for use, BE AWARE the radio gets HOT! Prolonged use or use on a busy frequency would not be recommended. Also remember this is a dual band HT please use a proper antenna while in this mode to avoid a high SWR, we should all know better... Right?"

Someone else said:

"I found that marine weather reports at 162.40MHz in my area were received much better on the SUB-VHF band, than on the VHF band..."

"If you are having problems with intermod, try switching bands (i.e. using the SUB-VHF band rather than the VHF band.)"

This modification is read 1248 times.

[top of page](#)

19-07-1998

(TH-78) Cloning

The TH-78a's memory can be copied from one TH-78a to another TH-78a entirely through radio waves "over the air" (i.e. without cables or other special equipment). Theoretically, this could be done via repeaters, although I've never heard it done. Allegedly this requires a mod that includes removal of D5 or D6, but I haven't researched it.

Cloning is a real boon to groups that want a bunch of radios to contain the same memories, such as amateur radio clubs, search and rescue units, and people too lazy to program their radios. Of course, given that the ME-1 memory expansion unit has 250 memories, laziness is understandable :-)

1. Set both radios to the same frequency.
2. Activate both radios by pressing the '0' key while turning the power on. The radios will display the word "clone".
3. Now, click the PTT button of the "master" radio. The radio will transmit in the economy low power mode. This may take about 4 minutes for fifty channels, or 20 minutes for the 250-memory ME-1. When the data has been transferred, both radios will revert back to their original frequency.
(It is recommended that a dummy load be used to prevent unwanted interference.)
4. Turn both radios off and then on again. The slave is now a mirror-image of the master radio.

This modification is read 1208 times.

[top of page](#)

19-07-1998

(TH-78) Cellular Telephones

Cellular phones operate at (tx) 824.040 - 848.970 (rx) 869.040 - 893.970, within reach of your modified TH-78a. The increments are, however, every 30kHz; the TH-78a will only increment in 25kHz steps at this frequency range, so the exact cellular frequency cannot be tuned in (most of the time).

This modification is read 1479 times.

[top of page](#)

19-07-1998

(TH-78) Battery life on the TH-78A

wd6cmu@netcom.com (Eric Williams) says:

Some people have complained about the battery life on the TH-78A. I came up with these tips by checking out the power consumption under various configurations. In the case of power-saver mode, figuring out the average current with my DVM was impossible, so I ran the radio on a large capacitor and timed how long it took to die. These tips won't solve everything, but they might help.

The rig draws close to 2ma even with the power turned off, so don't leave the rig off with the battery installed for several days and expect full capacity to be maintained.

If you're only using one of the bands, shut down the other to extend your battery's life -- current consumption with the squelch closed is cut by almost a third.

If you're monitoring two frequencies on the same band, use the f2 button to receive both simultaneously rather than scanning between them -- the battery saver with two receivers will use about half the current of one receiver that is scanning.

You can make up a battery pack by putting nickel metal hydride AA cells in a BT-8 battery holder. A small strip of aluminum from the positive battery terminal to the depression in the top of the case will allow you to recharge the pack inside the rig. This will give you 1000mah capacity without enlarging the size of the radio, and NiMH cells have no memory effect. (But they **are** expensive.)

This modification is read 1360 times.

[top of page](#)

19-07-1998

(TH-78) Game Mode

aviator@athena.mit.edu (who no longer exists), who credits james@brokaw.lcs.mit.edu for "much of this".

To enter the game mode press M and PTT during power-up. Be careful not to accidentally reset the memory, which happens with M + power-up. (Don't freak; you'll see the same "all screen items lit" when entering game mode as when you reset memory.) To exit the game mode at any time, press the LAMP key. The volume, lamp, or frequency settings can't be changed while in game mode.

The top part of the display will show "H.00", which represents the high score. The lower part shows a scrolling message, "PRESS ANY KEY". Pushing any key starts a "Follow Simon" type game. The display will briefly show one of the characters '1', '2', '3', or 'F'. Press the corresponding key. The game consists of repeating the displayed character sequence, which increases by one character each round.

After you "win" the Simon memory game by getting correctly entering a sequence of twenty characters, the next game is a draw poker game.

The way it works is that you choose your bet (from 1 to 10) by pressing '2' to increment the bet and '5' to decrement the bet. Then, press 'F' to deal the five cards. The face value of the cards is displayed, and the suits can be seen at any time by holding down the PTT key. Any number of cards may be discarded, and to select (or deselect) a card for discarding, press the keys '1', '2', '3', '4', or '5'. If a card is selected for discard, it is displayed "face-down".

Press 'F' again to draw new cards. Your new cards will be displayed, and then if your hand is 2-pair or better, the screen will show the rank of your hand on the left (2P for 2-pair, 4K for four-of-a-kind, etc.). On the right the pay-off for that hand will be displayed. Your bet is multiplied by the pay-off factor, and the resulting pile of cash is displayed in the right hand side of the upper screen. (The left-hand side of the upper screen contains your table stakes, which are initially 100 coins from winning the Simon game.)

If you win the poker hand, pressing any key steps into the next stage. If you lose the poker hand, your bet is deducted from your stakes and you are asked to start another poker hand. In the next stage, you are asked "TRYB/S" which means, "Do you want to try double-or-nothing in a guessing game for Big or Small cards?" Press 'F' for yes, press TONE for no. If you say no, your winnings are credited into your stakes and you are asked to start another poker hand. If you say yes, then a single shuffling/incrementing card is displayed on the left, and three stars are displayed on the right. You have to choose to go for either BIG or SMALL, by pressing '2' or '5'. You can keep pressing '2' and '5' to change your mind. When you are ready, you must try to hit the 'F' key to stop the rotating card display, and the card will show, and you will either win, lose, or draw. If you draw, you have to play big/small again, I think. If you lose, your winnings are gone and you can play poker again. If you win, your winnings double and you are asked whether you want to play big/small again.

The payoffs on the poker are set against you, odds-wise; the double-or-nothing game includes a draw, so the odds are against the player there unless you can time hitting the 'F' key to win more than half the rounds. I haven't managed to do this, so I don't know if there is anything beyond this, all I know is that when the table stakes are exhausted, you go back to playing Simon again.

This modification is read 1335 times.

[top of page](#)

19-07-1998

(TH-78) TH-78 - antenna hints

Hello everybody! Recently I decided to check the performances of small "Duckie" antenna specified as T90-0444-XX in TH78 manual. I found that on 2 mtrs band this antenna, at first, has quite narrow bandwidth and, at second, tuned about 144.000 MHz or even some lower (at the same time 70cm bandwidth seems to be enough...).

Because of "integrated design" of this antenna it would be nonsense to cut the top end, so I tried to find another way to tune it to the middle of 2m band. At last, the problem has been successfully solved! So, you can easy tune the central frequency up to 147 MHz - just place a copper ring in the middle of conical surface of antenna (between "OO"s as shown below):

```
+-----Ê-----  
|-- |          |          +-----+  
|-- | K E N W O | O D | dual band antenna | )  
|-- |          |          /+-----+  
+-----ø-----/
```

copper ring (about 13 mm internal diameter)

The ring made of 0.3 mm wire gave me frequency shift from 144 to 145 MHz; if you need higher frequency, you should use wider ring (about 4...5 mm for 147 MHz) - you can solder it of thin copper.

Don't use SWR meter for tuning! The best device is scanning scope or, at least, simplest RF field meter and your HT as VHF generator. That's all... 73, de Serge.

RK3AXJ @RK3KP.MSK.RUS.EU 28-Aug-94

This modification is read 1424 times.

[top of page](#)

19-07-1998

(TH-78) 9600 Baud FSK-Modifikation für das Kenwood TH-78E

From: DG1SFJ @ DBORBS. #BW.DEU.EU

Hallo Kenwood-Freunde,

hier bekommt Ihr nun die Anleitung zum Modifizieren eures TH-78's, um damit 9k6 zu machen...

Ich übernehme keine Verantwortung für die Richtigkeit der in der Anleitung gemachten Angaben und für Schäden die im und am Gerät durch die Modifikation entstehen. Die Anleitung ist etwas größer geworden, dafür aber (hoffe ich) einfacher und auch für Nicht-Profis (etwas Löterfahrung braucht man schon!!) verständlich.

1. Öffnen des Gerätes:

Alle Stecker incl. Antennenkabel abziehen, die beiden Drehknöpfe und danach die Squelch-Regler abziehen. Den Akku entfernen und mit einer halboffenen Schere oder Zange die beiden Kranz-Muttern an den Squelch-Reglern rausdrehen. Jetzt fällt der obere Gehäusedeckel ab, aber auf die beiden Gummiringe auf den LED's achten, sie fallen leicht runter...

Auf der Rückseite des Gerätes die 3 Schrauben lösen, ebenso wie die kleine Schraube an der Seite beim Antennenanschluß. Vorsichtig das Gehäuse öffnen. Nun die Hälfte mit der LCD-Anzeige nach links legen, und die andere nach rechts (wer hätte dies gedacht :-)
An der Platine mit den Akkukontakten die zwei kleinen Schrauben unten rechts und links losschrauben, und das Kabel davon abziehen. Diese Platine könnt ihr nun zur Seite legen, und das CTCSS-Modul sollte, falls vorhanden nun dem Gerät sanft entnommen werden.

Jetzt nur noch die drei Schrauben auf der Platine lösen, auf der die Squelch-Regler sitzen. Dann das geschirmte Kabel, das ebenfalls auf der Platine sitzt und nachher durch ein Loch in dieser verschwindet, aus der Buchse rausziehen. Nun die gesamte Platine und die Gehäusehälfte(LCD) nach rechts legen, und auf das kleine Kabel von oben und auf das Flachbandkabel aufpassen...

Damit liegt die Rückseite der Platine mit den Squelchreglern vor euch bereit für die Modifikation (letzte Möglichkeit zum Aufgeben des ganzen Vorhabens ;-)

2. RX-Modifikation:

Auf dieser vorher genannten Platinenseite befinden sich nun 2 Empfänger-IC's des Typs MC3372D, je einer für VHF und UHF. Auf dem Schaltplan befinden wir uns nun auf der (X57-409X-XX B/4) TR-RX Unit, wobei das UHF-IC dort IC303 heißt. Dort greift ihr das Diskriminator-Signal von Pin 9 ab. Um nun den richtigen IC auf der Platine mit dem Lötkolben zu traktieren, legt ihr diese wie folgt vor euch:

Die Squelch-Regler zeigen nach rechts, ein Flachbandkabel geht von oben zur Druckguß-Schalenhälfte des Gehäuses. Nach unten geht das andere Flachbandkabel Richtung LCD-Gehäuseteil. Das UHF-Empfänger IC liegt nun weiter rechts, nahe einem IC mit der Aufschrift "4560 246" in der Nähe der Squelch-Regler. Wenn ihr diese habt, so lötet ihr nun ein Kabel an Pin 9 an den MC3372D (in diesem Fall oben rechts das letzte Pin). Es gelten die üblichen Tips für SMD-Löten (vorher noch mal üben!). Das Kabel nun um ca. 90 Grad nach rechts biegen, Richtung Squelch-Regler. (solltet ihr es Richtung Akku biegen, und da auch langführen, dann bekommt ihr ein übles Rauschen auf dem gesamten UHF-Band und die Squelch läßt sich nicht mehr schließen...). Abgeschirmtes Kabel ist also anzuraten, ich habe keines verwendet, allerdings unter Beachtung der Richtung des Kabels wie oben beschrieben.

Damit ist der Demodulator-Ausgang vom UHF-Empfänger IC schon mal nach aussen gelegt und ihr seid (hoffentlich) bereit für das Abgreifen der TX-MOD vom Flachbandkabel.

3. TX-Modifikation:

Dieser Teil der "Modifikation" ist eigentlich auch kein Problem, man sollte nur ruhige Hände und scharfe Augen haben... Der Umbau spielt sich wieder in der (X57-409X-XX B/4) TR-RX UNIT ab, wobei die uns interessierende Leitung vom Mikrofonverstärker (IC 301) über ein Poti (VR302) zum Flachbandkabel links auf dem Schaltplan geht, welches dort mit B bezeichnet wird. Das Signal liegt von unten aus gezählt an Leitung 11 (MODU) an. Wenn die Platine genauso wie vorher vor euch liegt, so seht ihr oben ein Flachbandkabel aus Plastik, das in die Gehäusenhälfte geht, die mit einer Druckgußhaube abgedeckt ist (genau die mit dem Antennenanschluß), und rechts wieder die Drehregler.

An diesem Flachband-Kabel werden nun von links nach rechts genau 11 in Worten ELF Leitungen abgezählt. Es sieht so aus, als ob keine Leiterbahn von da aus weiterführt, da die Platine aber innen noch eine Schicht hat, kann man das jetzt noch nicht erkennen. Um die Zählrichtung noch mal zu verdeutlichen: Rechts die Squelch-Regler, links gar nichts, und von links aus die Leitungen des Flachbandkabels abzählen 1,2,3,...,11 und an dieser Leitung liegt die Modulation für den VCO. Also genau hier, wo das Flachbandkabel an der Platine festgelötet ist, wird nun ein Kabel angelötet, aber aufpassen: Erstens hält so ein Kunststoff-Flachbandkabel nicht viel Löterei aus und zweitens ist schnell mal eine danebenliegende Leitung auf der Platine mitangelötet (ist mir beinahe passiert...). Das Kabel nun wie vorher auf dem kürzesten Wege nach oben zu den Squelchreglern legen.

4. Letzte Schritte:

So, die typischen 2 Drähte sind angelötet, ist auch keine Brücke unerwünscht entstanden?! OK, dann das ganze Gerät in umgekehrter Reihenfolge wie beim Zerlegen unter Punkt 1 wieder zusammenbauen, kurzer Funktionstest, und dann kann das ganze schon an das FSK-Modem angeschlossen werden. Im TNC-Handbuch sollte man nun nachlesen, wie die Modulation am besten einzustellen ist (ich habe das mit einem zweiten Empfänger getan).

Gedanken muß man sich nur noch über die Verbindung zur Aussenwelt machen, entweder einen kleinen Platinensteckverbinder (3-polig und einen Pol davon abfeilen) oder eine 2,5mm Monobuchse (paßt wahrscheinlich ebenso nur ab- gefeilt rein) in den Platz (von oben auf die Funke gesehen) zwischen Antenne und erstem Drehknopf, weil hier der einzige "große" Platz ist. Bei mir hängen zur Zeit einfach die beiden Kabel oben heraus. Wer eine bessere Lösung hat, sollte mir diese unbedingt schreiben !

5. Ergebnis:

Angeschlossen habe ich mein TH78E an einen TNC 2 H, auf den sich das nun folgende Ergebnis bezieht:

Die TXDELAY arbeitet mit 10 einwandfrei bei mir, mit 9 wird es etwas weniger gut, und 8 war bei mir die untere Grenze. Weniger ging absolut nicht, und ich nehme zur Zeit 10 oder 9.

Die Filter am TNC habe ich noch nicht mit einem Bit-Error-Test geprüft, wenn ihr sowas mal macht würde ich mich freuen, wenn ihr mir die Ergebnisse per PR an meine Box DBORBS schicken könntet.

Das TH-78 ist bestimmt nicht ideal für FSK, aber wenn es wie bei mir das einzige 9K6-fähige Gerät ist, so geht das glaub ich schon. Das ganze habe ich so seit einem Monat in Betrieb, und es scheint dem Funkgerät nicht zu schaden. Dankeschön noch an Andre, DG3SDK, der mir beim Umbau geholfen hat !

So, und nun viel Spaß mit 9600 Baud PR !

Wenn ihr euren Funk auch mal umgebaut habt, dann schreibt mir doch mal, damit ich seh, wie es bei euch so geklappt hat ... ihr dürft mir natürlich auch schreiben, wenn es noch Fragen oder Probleme gibt !

Ansonsten 73 und 55 von Jochen, QTH Schwieberdingen, DG1SFJ @ DBORBS

19-07-1998

(TH-78) TH78A, USA model don't have 1750 Hz

TH-78A (U.S.A. version) --> TH78E (European version) MODS.

If you bought a TH78A in the USA you don't have the 1750 Hz repeater tone access, but you can change that !

Apart from the well-known six diodes, the new CPU has 2 green wires.

In order to use the TH78A in EU, you must do the following:

1. First you have to remove D2 for the standard EU bands (144-146 and 430-440 MHz).
2. Now control that the 2 green wires and the 5 other diodes are installed (D1, D3, D4, D5 and D6).
3. If you need band expansion and components location, please see the mods below.

Although the TH78A has a special bandpass filter for the US 70cm band, I could not notice a decrease in sensitivity in the EU part of the 70 cm band.

There is a function change for 3 knobs; please see below and also p. 6 and 7 of your INSTRUCTION MANUAL.

TH-78A	-->	TH-78E

LAMP	-->	TONE 1750 Hz
CALL	-->	LAMP
TONE	-->	CALL

Now, you can choice between the CTCSS tones and the 1750 Hz with the following sequence: F + LAMP (the new TONE !) and then the right rotary encoder to make your frequency choice.

This modification is read 1218 times.

[top of page](#)

23-01-1999

(TH-78) Crossband repeat, extended RX/TX

Owner assumes all responsibility for modifying or using these modifications!.

The following mods will provide for Crossband Repeat and extended receive and transmit on the Kenwood TH-78A HT.

I believe other functions are also enabled by these mods. which I have not found yet but I will update the file as news progresses.

Diode #4- Crossband Repeat

Diode #5- Extended Receive and out of band Transmit.

Remove all screws and open radio as explained in the Kenwood manual for installing the memory expansion module.

On the back cover you will find the memory expansion module socket and a copper shield to the upper left corner of it.

Under this shield their will be a row of SMC diodes which are unmarked in a vertical configuration to the lower right portion covered by the shield.

1. Remove the shield at its four corners with a solder sucker and SMALL! iron.
2. Carefully count down from the 1st diode in the row to the fourth one and remove for crossband repeat.
HINT: I found if you BRIEFLY touch the iron to the right side lead while gently pulling up on the SMC diode it should completely come off without needing to apply heat to the other side and further risk board damage.
I used a pair of right angle surgical tweezers for this.
3. Just as above you may remove the fifth diode to preform the extended receive and transmit modification.
4. Reset the CPU (yes you will loose all of your programed memories! argh!) by pressing Function for more than one second and then "0".
YOU HAVE NOW COMPLETED THE MODIFICATIONS!
5. For 800Mhz go to the UHF band with the band switch and press Function for more than one second quickly following with a press of the Band switch again. 8---.-- will appear.
6. For 300MHz go to the VHF band and repeat as above. Original bands are restored by repeating the "F Band" sequence.

MY observations... All original functions have maintained the same which is great. Aircraft band which was accessible before the mod remains with the same characteristics. It seems that VHF-High band has improved a bit on sensivity where it was dead as a dog before the mod (above 155.000MHz) but the 162.000 MHz band where weather radio is is still a bit deaf for reception at any distance but about 20 Miles. This depends on your (or my) terrain and transmitter output power.

On UHF all public safety frequencies up to about 500 MHz seem to come in well but sensivity greatly drops from there (we really can't ask for more). Frequencies can be programed in up to the 920MHz ham band but I have no way of measuring sensivity. 800MHz works but the signals are very weak, you must be near the transmitter for reception. Assuming you are in the town or city where the transmissions originate it should work.

Transmit is enabled up to and incl. 500MHz but after testing this on a frequency counter I find that a signal is only generated to about 490 MHz, even though the trans. LED shows output in the higher frequencies.

Crossband repeat seems to work fine but the audio is unacceptable for use, BE AWARE the radio gets HOT! Prolonged use or use on a busy frequency would not be recommended. Also remember this is a dual band HT please use a proper antenna while in this mode to avoid a high SWR, we should all know better... Right?

After first booting up the CPU in the mod I found that the message screen showed "Cloning" so it seems that this radio now has cloning capabilities. After searching I have found that holding the "0" key and powering up the radio will display the clone feature, see below for further explanation. This leads me to believe that this HT may have some more "Hidden" features that I am trying to find, some may be useful.

Thanks to Gary KC8UD who sent me the following via packet

CLONING:

The TH-78 can be cloned without cloning cables or special equipment. It is done entirely with RF, and, in fact, can be transmitted over the air, and even via repeaters. This may be extremely useful for those users who do not have the patience to program their own radios themselves. This application would also be useful for clubs and user groups. (However, this can take as long as 50 minutes with the ME-1 expansion module. It is recommended that a dummy load be used to prevent unwanted QRM.)

1. Both radios must be on the same frequency.
2. Activate both radios by pressing the "0" key while turning the power on. The radios will display CLONE.
3. Now, click the PTT of the "master" radio. The radio will transmit in the economy low power mode. This may take about 4 minutes for fifty channels.
When the data has been transferred, both radios will revert back to the original frequency.
4. Turn both radios off and then on again. They will now operate normally while the slave radio has the same memory contents as the master radio.

FREQUENCY EXPANSION

(1) You can receive from 340 - 399.987 Mhz FM by removing chip diode D8 on the control unit. To access this function, press the [F] key for one second, and then the [LOW] key. This toggles between AMATEUR, AIR band (AM) and 360 Mhz. AM and FM modes are selected automatically, depending on frequency.

** Since "F" for a second and "Low" toggles the power output, I wonder **

There is also a couple of arcade type games on the TH-78A. To start the game you press and hold [PTT] and [M] keys while turning the unit on. The first game is a follow me type game. The radio beeps and shows a sequence of numbers flashing on the screen. You have to match the same sequence on the tone pad. Each time the sequence gets longer by one number. You have to keep remembering the sequence as one gets added each time. Once you get to a certain high score on that game, it breaks into a poker type game. To exit the game mode press the LAMP key at any time. The receiver still works in the game mode and you can adjust volume but no other features.

RG> The games seem to work fine and it is interesting that they have inserted that into the programming of the chips. Does anyone know of any further features in the radio be it games or radio functions.

This modification is read 1384 times.

[top of page](#)

21-04-2000

(TH-78) TH-78A Clone failure w/ME-1 installed

Author: Kenwood Communication, inc.

Service Bulletin no. 997 (3 August 1992)

Some TH-78A owners have reported a failure of the cloning feature after the ME-1 Memory expansion unit is installed. The following modification will correct this problem.

Note: Since the Cloning feature is not one that is mentioned in the operators manual, and is basically an unsupported feature, we do not anticipate many reports of this symptom.

Warning: This radio uses micro-sized surface mount component, and/or multi-layer circuit boards. *If you are not familiar with the techniques for service of this type of equipment do not attempt this modification yourself.* You will invalidate your warranty if you attempt to modify the equipment and damage the radio. If you are at all in doubt about your qualification to perform this modification you should seek qualified assistance.

Required parts:

IC-7 Microprocessor, (HD404629A32H)

Procedure:

1. Remove the battery, and antenna.
2. Remove the 3 small black #0 phillips head screws from the rear panel of the transceiver and the 1 small black #0 phillips head

screw from the side of the transceiver near the antenna connector.

3. Carefully separate the front panel from the rear of the transceiver and fold it over to allow access to the rear of the front panel.
4. Unsolder the brass shield from the circuit board (4 solder points).
5. Locate IC7 the largest of the two IC's under the shield, unsolder and remove.
6. Install the replacement part. Make sure there are no solder bridges or cold solder connections.
7. Reverse steps 1 - 4 to reassemble.
8. Press and hold the "M" key on the front panel, turn on the power, then release the "M" key to reset the microprocessor.

This modification may be covered under warranty.
Time required for this modification is 1 hour or less.

This modification is read 1171 times.

[top of page](#)

22-04-2000

(TH-78) TH-78A Call channel tone frequency error (Revised)

Author: Kenwood Communication, inc.

Service Bulletin no. 1008 (27 May 1993)

Symptom:

When the TSU-7 CTCSS unit is installed the tone frequency of the CALL CH is overwritten under the following circumstances:

1. Program the Call Channel with a tone between 67.0 Hz and 114.8 Hz. For example: 100.0 Hz.
2. Program any memory channel with any frequency and tone frequency. For example: 118.8 Hz.
3. Recall the memory channel to the VFO.
4. Recall the CALL channel. The tone frequency of the call channel changes to that of the memory channel. (Changes from the programmed 100.0 Hz in the example to 118.8 Hz).

Parts required:

IC-5, Original part 75517GF-155-3B9, change to: 75517GF-170-3B9

Procedure:

This symptom is caused by a microprocessor programming error. The cure is to replace the microprocessor (Control Unit X53-3420-00, IC-5) with the replacement part.

Note: Units with serial numbers 404xxxxx - 406xxxxx have a limited production microprocessor installed. This microprocessor incorporates the correction for this error. The part is labeled 75P518GF-JDF3. You do not need to replace this IC. Units with serial number 407xxx and after will have the 75517GF-170-3B9 microprocessor installed at the factory.

Caution: *This modification requires soldering equipment rated for CMOS type circuits. It also requires familiarity with surface mount soldering techniques. If you do not have the proper equipment or knowledge do not attempt this modification yourself. Seek qualified assistance.*

Time required for this modification is 1 hour or less.

This modification is read 1169 times.

[top of page](#)

22-04-2000

(TH-78) TH-78A/E Left encoder inoperative

Author: Kenwood Communication, inc.

Service Bulletin no. 1013 (7 May 1993)

Symptom:

The left encoder on the top panel does not work. This symptom usually occurs when the unit is reassembled after service.

Cause:

If the front panel is removed without removing the top panel the Control unit might come in contact with the encoder mounting hardware. This causes chip resistor R97 to be sheared from the board.

Correct Action:

Delete chip resistor R97 from the control unit and add a short jumper wire in its place. Resistor R97 was used to prevent feedback during transmit. It has confirmed by our engineering staff that the performance of the circuit will not be adversely affected by this change.

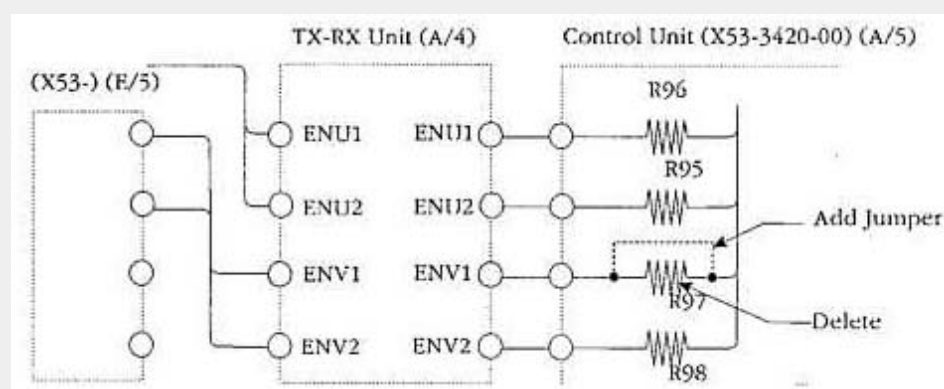

Time required for this modification is 30 minutes or less.

This modification is read 1215 times.

[top of page](#)

23-04-2000

(TH-78) TH-28/48/78 Difficult battery insertion

Author: Kenwood Communication, inc.

Service Bulletin no. 1028 (29 June 1993)

Symptom:

Insertion of the battery into the transceiver is difficult or impossible due to problems with the release lever.

Corrective Action:

- A temporary cure is provide by loosening the two screws securing the holder, shifting the holder to the extreme left, then retightening the screws.
- A permanent fix is provide by replacing the holder and release level with new parts that have been deburred and modified to allow relocation of the release level.

Parts required:

Qty	Description	Kenwood Part No.	Circuit description
1	Holder	J19-1515-23	NA
1	Release lever	D10-0610-13	NA

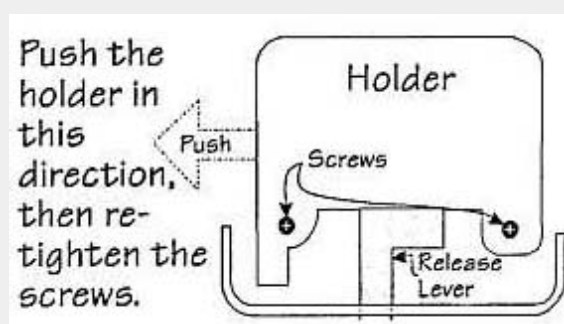

Time required for this modification is 30 minutes or less.

This modification is read 1214 times.

[top of page](#)

23-04-2000

(TH-78) TH-78A Microprocessor change

Symptom:

Due to a recent rule change by the FCC it is no longer possible to supply transceivers, or provide replacement microprocessor that would allow a transceiver to receive in the 800 MHz band.

Corrective action:

The microprocessor program of IC5 has been modified to prevent 800 MHz band reception. Production has been changed beginning with serial number lot 510xxxx. Units produced after this point will not be capable of 800 MHz reception.

Parts required:

Qty	Description	Old part No.	New Part No
1	Microprocessor	75517GF-170-3B9	75517GF-257-3B9

Procedure:

When ordering a replacement microprocessor you will be supplied with the new version. Please make sure your customer understands the limitations of this new

This modification is read 1317 times.

[top of page](#)

19-07-1998

(TH-79) TH-79 clone memory contense of two radio

Dear friends

Hope a lot of you enjoy to play with the TH 79. I want to explain how to clone the memory contense of two radios on the air. The clone procedure is same with all others. (use of DTMF tones, do not disturb transmission etc.)

You must take care that both radios are really same: both have extended range or not, both are E-version or not etc.

It will cause some problems if you try to clone i.e. an E version without expansion into a A- or J version.

If you have both radios please hold down the -0- key / PAG L Key when you switxh on the radio. So you see the letters CLONE on the display. Please push the ptt on the radio which has to be the master.

It takes a time to transmit all memory with maybe names, call sign etc.

After Clone is finished you see END written in Display. Best is to switch of both radios. After switching on again you will have two same radios !

Enjoy it and best wishes..

73 from hanno

This modification is read 1740 times.

[top of page](#)

19-07-1998

(TH-79) TH-79A extended RX and TX range for new radio

Remove diodes D304 and D307.

Thats all...Don't cut the green wire, or install any jumpers as before.

Just take out these diodes...A WHOLE lot easier than moving and jumpering..

With this mod the capability is same as the other mod, ie: 67-174.995 and 400-511.995 RX, 136-174.995 and 400-511.995 TX.

Mine wouldn't recieve all the way down to 67 MHz, but it did go to 85 MHz.

It changes to AM receive below 136 MHZ automatically.

My TX power was gone above 505 MHz but was solid elsewhere in VHF and UHF.

Enjoy, but don't create problems with the new capability...Wouldn't it be nice if Kenwood would make a RX only mod with these capabilities and we wouldn't have to worry about accidental transmissions where we shouldn't be transmitting. I, for one, don't want or need to TX, just RX...

73, Cole AA7RDAugust 11, 1994

This modification is read 2698 times.

[top of page](#)

19-07-1998

(TH-79) TH-79A Wide Band Modification

Following is a modification for the Kenwood TH-79A Dual Band HT which opens it up to tuning from 67-174 MHz and 400-511 MHz. Actual receive was 85-135.995 AM and 136-179.995 FM with reasonable (0.5 microvolt or better) sensitivity at all the points I measured. Transmit was 136-179.995 and 400-511 with power dropping off at the ends but still usable (about 0.5w on the high scale at the band edges).

This mod is the official one from Kenwood, taken from a data sheet put out by them. It supercedes an earlier one I posted involving moving some diodes. As usual, I take no responsibility for the mods, or your use of the unit after mod. Please exercise good judgement and don't endanger our ham bands with your irresponsible actions.

WARNING-CAUTION-LOOKOUT-ETC!!!

The diodes to be moved are microscopic!! About 1mm long by 0.5mm wide.

This mod should be done by professionals on a closed track only.

Children, do not attempt this at home!! Requires extremely small soldering tools and MUCH skill.

1. Open the unit by removing three screws from the back and one under the DC power input cover. Carefully separate the front and back pieces. The two case halves may be disconnected by pulling the wired plug and by prying the brown latch on the ribbon cable connector up enough to release it.
2. On the front PC board in the lower right corner as viewed from the rear with the knobs pointing up there are seven spots for diodes in a row, with one diode missing.

```
| o o o o x o o |  
-----  
 2 3 4 5 6 7 8
```

The numbers are D302-D308, left to right, with D306 missing.

3. Remove diodes D304 and D307.
4. Reassemble and apply power. Mod complete.

PS:

Just cutting the green wire by the recharging jack is the MARS mod.. Don't cut if you intend to do the above mod.. Good Luck.Cole AA7RD

This modification is read 2415 times.

[top of page](#)

19-07-1998

(TH-79) MARS/CAP modification for the new Kenwood TH-79A

Here is the MARS/CAP modification for the new Kenwood TH-79A dual-band HT. Usual disclaimers about doing mods apply.

1. Remove battery.
2. Open case by first removing 3 screws (#00 Phillips) on back and 1 screw on side hidden underneath the rubber flap covering the DC power jack. Gently pry apart starting at top; BNC connector will move with back, knobs with front.
3. Spread unit out. Wires will "hinge" on the side with the PTT button.
4. Looking on the back of the keypad (front) half, locate green wire on upper left, just below the CTCSS decoder module.
5. Neatly cut this green wire, and tuck back in so ends won't touch each other or other components.
6. Reassemble.

Programmed memory will be lost since the CPU will notice the strap change and reset itself.

End result -

```
Before: VHF RX - 118.000-173.995 TX - 144.000-147.995  
UHF RX - 438.000-449.995 TX - 438.000-449.995  
After:  VHF RX - 118.000-173.995 TX - 142.000-151.995  
        UHF RX - 420.000-449.995 TX - 420.000-449.995
```

Automatic repeater offset and shift selections remain normal.

If I read the schematic right, the green wire corresponds to "W301", which also serves the same purpose as removing "D308". More research needs to be done on other mods; I'm especially interested in extending UHF receive beyond 450. There is a row of diodes right below the uC which appear to be D302 through D308, the configuration straps. HOWEVER - I need to caution anybody thinking about playing with the diode straps that it will not be a casual operation. For one thing, the diodes are SMD "603" style - extra, extra tiny - and the plastic board hold-downs molded into the front case are right on the landings for most of the diodes. This means that the board will have to be removed from the case (a very involved procedure), and working with the tiny diodes *will* require magnification tools as well as the correct micro-tip iron. It is not a job for the inexperienced or all-thumbs.

Also, as noted previously, the non-US versions of the TH-79 have an 800 MHz receive section. All RF components of this section are not present in the US version. Frankly, it would easier to import a gray-market version of the radio than it would be to attempt restoring this coverage in the US with parts.

...mike musick/NOQBF

19-07-1998

(TH-79) Hidden options TH-79

Playing around with my Kenwood TH-79 handheld, I discovered some "hidden" possibilities that are not mentioned in the user manual.

A. Clone:

Action to be taken by both stations:

1. Switch power off
2. Press both the PTT and the VFO key, and keep them pressed while switching the power on
3. Switch power off again
4. Press the PAG.L key (figure zero) and keep pressed while switching on the power again Now, in the display the indication CLONE will appear

As soon as the station that will transmit presses the PTT switch for a while, cloning will start. This will take several minutes. After cloning is finished, the transmitting station's display will return to "normal", whereas the display of the receiving station will indicate END.

B. Switching to other VFO's (other bands)

As you may know, in the menu 4 VFO's are possible, namely menu nrs. 13, 14, 20 and 21. Menu 13 and 14 being the "standard" VFO's for vhf and uhf and menu 20 and 21 for the bands 300-399 Mc and 800-999 MHz.

It appeared to me that the vhf band (menu 13) can be switched to 300-399 Mc (menu 20), whereas the uhf band (menu 14) can be switched to 800-999 Mc (menu 21).

Just make the band you like to change the active band (PTT indication in the display near to the frequency) and then first press the function key, followed by pressing the LOW(hi/lo/el) key.

Needless to say that in order to be able to receive those "alternative" frequencies the handheld should have been modified (in my case I provisionally did cut the green wire).

I hope you will enjoy these "hidden" options.

In case I do discover more of them, I will share them with you.

On the other hand, if you have further information on hidden options and/or modification I would be please to know them as well.

Best 73 from
Hans - PA3ESZ @ PI8VNW.

19-07-1998

(TH-79) TH-79 WIDEBAND-RX ONLY

Yeahh, this is the modification you all have been wating for !!!

Recently I purchased a TH-79A in the United States having the idea that is was possible to convert it to a model TH79E.

After some research i discovered that it was possible to make a TH79E.

Inspired by this succes i wanted to have the extra RX possibilities, and after the so called 'green-wire' cut i had the wanted RX but also TX. Because of government regulations this extra TX it is not allowed in Holland. So i searched a little farther and fixed the job.

The following modification is called the E3 modification.

This modification gives you:

TX 430-440 MHz and TX 144-146 and RX for all built in frequencies that the hardware of your radio is capable to receive.

What to do ?

Find some one that can manage very tiny SMD components. Cut the green wire and change your diodes under the CPU so that it looks like this:

X	X	-	-	X	X	X	X	X
R	D	D	D	D	D	D	D	R
5	3	3	3	3	3	3	3	4
0	0	0	0	0	0	0	0	0
2	2	3	4	5	6	7	8	2

X = component present
- = no diode here
R = Resistor
D = Diode

R 402 and R 502 are only displayed for reference.

Hint ! in the SCHEMATIC DIAGRAM you received with your radio there is also a diode program diagram wich lists the E3 version and other versions also.

For example the K version is the American version. Please note that in this table D 302 and D 305 are not drawn, and have to be present.

Background information:

I chose for the E3 type because i had a modification note of the TM 733.

In this note i read what the different type's (letters) had for operating RX/TX frequency's.

So if you want to find out what the other types would do see if you can put your hand on this TM 733 modification note.

WARNING:

The radio you purchased is very expensive, don't give me the blame if something does not work.

If you diside to make this modification is on your risk only !!!

THIS IS A SPECIALIST JOB BE WARE OF THE TINY COMPONENTS !!

For stations who live nearby i can give assistance.

REMARKS

Only the normal TH79E HARDWARE is capable of receiving 900 MHz.

This is not possible for the other versions.

FINALY

I hope you will enjoy these "hidden" options.

In case I do discover more of them, I will share them with you.

On the other hand, if you have further information on hidden options and/or modifications I would be please to know them as well.

Best 73 from

Ron - PE1OZH @PI8EZQ

This modification is read 2054 times.

[top of page](#)

19-07-1998

(TH-79) Umbau TH79e auf 9k6

From: DG3MMU @ DBOKCP. #BAY.DEU.EU (Andreas)

Hier kommt ne Anleitung zum Umbau des TH-79e auf 9k6.

1. Oeffnen des Gerätes:

Alle Stecker incl. Antennenkabel abziehen, den Akku entfernen.

Auf der Rueckseite des Geraetes die 3 Schrauben loesen, ebenso wie die kleine Schraube an der Seite beim Antennenanschluss.

Vorsichtig das Gehaeuse oeffnen. Nun die Haelfte mit der LCD-Anzeige nach links legen, und die andere nach rechts (wer haette das gedacht :-)

Falls ein CTCSS-Modul drinne ist, kommt das auch raus :-)

2. RX-Modifikation:

Die vier Schrauben in der (ich nenn sie mal) "Power"-Haelfte (mit den beiden HF-Hybrids und dem vielen Kupferblech) rausschrauben und vorsichtig rausnehmen. Dazu muss noch die BNC-Buchse weggeloetet werden.

Auf der Unterseite gibts nen IC Marke Motorola MC3372D (Demodulator), der ist fuer UHF. Das RX-Kabel wird da am Pin 9 aneloetet. Damit ist der RX-Ausgang vom UHF-Empfänger IC schon mal fertig :-)

3. TX-Modifikation:

Im zweiten Gehaeusedeckel (mit den Potis und den MIC/Lautsprecher-Buchsen) gibt es eine "Tochterplatine", die den Mikrofon-Amp beherbergt.

Einfach die Platine runtermachen, ein Draht an den Widerstand neben dem IC 308 (TA75W558F) und das ist die TX-Einspeisung.

Ich hoffe, in der kleinen Zeichnung kann man was erkennen :-)

Der Draht wird am oberen Kontakt vom R angeloetet (wo das R steht), der betreffende Widerstand ist ein groesserer Widerstand als es die andren sind.

```
+-----+
!           R +           !
!  ##           +  *** (IC308)  !
!  ##           ***           !
!  ##           !           !
!  ##           !           !
!  ##           !           !
+-----+
```

Steckkontakt zur
grossen Platine

Wenn fertig, wieder die Platine auf den Kontakt stecken.

4. Letzte Schritte:

So, die typischen 2 Draehnte sind angeloetet, ist auch keine Bruecke unerwuenscht entstanden ?! OK, dann das ganze Geraet in umgekehrter Reihenfolge wie beim Zerlegen unter Punkt 1 wieder zusammenbauen, kurzer Funktionstest, und dann kann das ganze schon an das FSK-Modem angeschlossen werden.

Gedanken muss man sich nur noch über die Verbindung zur Aussenwelt machen, entweder einen kleinen Platinensteckverbinder (3-polig und einen Pol davon abfeilen) oder eine 2,5mm Monobuchse (passt wahrscheinlich ebenso nur abgefeilt rein) ins Geraet reinbauen.

Ich uebernehme keine Verantwortung für die Richtigkeit der in der Anleitung gemachten Angaben und für Schaeden die im und am Geraet durch die Modifikation entstehen. Die Anleitung ist etwas groesser geworden, dafür aber (hoffe ich) einfacher und auch für Nicht-Profis (etwas Loeterfahrung braucht man schon!!) verständlich.

Ok, 73 de Andy DG3MMU @ DB0KCP.#BAY.DEU.EU

This modification is read 1680 times.

[top of page](#)

19-07-1998

(TH-79) Kenwood TH-79A(D) Review

The TH-79A(D)'s approach to programming is largely intuitive, and that's an advantage when you're trying to become acquainted. Jumping from memory channels to VFO (and back) is as simple as pressing a single button. The same is true for hopping from 2 meters to 70 cm, or vice versa. When you're in the memory mode, twisting a single knob will step you through the channels. The same knob functions as a free-wheeling frequency control when in the VFO mode.

If you forget how to use a specific feature, the "guide" function is ready to assist. Simply press the F key followed by the GUIDE button. By rotating the ENC knob, you're presented with a list of functions. Each is described with text flowing from right to left across the display, Thanks to Kenwood's unique dot-matrix LCD, the scrolling instructions are easy to read.

After you've programmed the TH-79A(D), you can share the contents of the memory channels with other TH-79s through a wireless cloning feature. In fact, one TH-79A(D) can upload data to several others at once!

Several team members commented favorably on the multipurpose timer functions.

A battery-saving mode shuts down many of the energy-intensive functions if the radio is not used after 10 seconds. The time-out timer answers the prayers of many long-winded hams. If your favorite repeater drops out after, say, three minutes of continuous babble, you can program the timer to cut you off well before then. (The TH-79A(D) simply drops back to the receive mode.) Finally, the TH-79A(D) offers a timer that shuts down the radio completely if it hasn't been used for one hour. All of these timers are programmable, or they can be disabled altogether.

One interesting feature of the TH-79A(D) is not mentioned in the manual, although it is mentioned in the advertising: AM aircraft receive capability.

As it turns out, the TH-79A(D) has a hot aircraft receiver. Team members enjoyed listening to airliners in contact with Boston Center, or on approach to Bradley International Airport near Hartford, Connecticut.

The TH-79A(D) was judged awkward in only one respect: the operation of the squelch. There is no squelch control on the TH-79A(D) in the traditional sense (a knob). Instead, you must select among several squelch levels by bringing up the appropriate program menu. Most team members didn't find it too objection-able, but it might drive you up the wall if you're the type who often fiddles with the squelch.

Reprinted with permission from JULY 1995 QST, © ARRL

This modification is read 1818 times.

[top of page](#)

19-07-1998

(TH-79) Remote Base Operation with Kenwood 732/733

Kenwood has now simplified remote base operation of their mobile rigs with the TH79.

I will not give a step by step on how to control the mobile rigs, since they are different. However, to really understand this feature, I would first get to know the remote control feature on the mobile very well. This makes the following explanation a little clearer!

To access this feature, hold [PTT] and [MR] while [POWER ON].

The display will indicate -RC-, which I presume means 'Remote Control'.

If you have correctly matched your DTSS codes, frequencies, etc, the dual bander's keypad now becomes a function pad. Pressing certain keys enables or disables functions on the mobile rig by sending the DTMF sequences for you.

Please note that all this fuction does is send the DTMF tones over the air to control your mobile rig. I have not made a list of what each key does, but as the 79 sends the DTMF tones, the display will indicate the function. (i.e. - RPT ON, RPT OFF, TONE ON, TONE OFF, etc.)

73 de Clayton
KD4IDN

And this from Chuck Scott, N8DNX...

"The "RC" function is configured to directly control radios such as the TM-732. In fact, if you look at the layout of the microphone remote commands for the 732 it very closely matches the key assignments for of the "RC" mode. Since I have a TM-732 installed in my car, I had a chance to try this out and it's VERY convenient. Everything from direct frequency entry with the "F" key to enabling X-Band repeat. I'm really surprised they aren't marketing this feature of the radio.

This modification is read 1648 times.

[top of page](#)

19-07-1998

(TH-79) Post Modification Spec Sheet

Author: Clayton Wagar, KD4IDN

Here is a small chart showing the measured specifictions of TH79 S/N 60300272 after modification. The measurements were made with an IFR 1200S Service Monitor, on the bench, with a 6V power supply. Your milage may vary - these are just what happened with mine, and I would suspect that most units are pretty similar.

73 de Clayton
KD4IDN

Band - VHF	Frequency	Sens (uV)	Power	Mode
	108	4	-	A3
	110	2	-	"
	115	.75	-	"
	120	.40	-	"
	125	.30	-	"
	130	.30	-	"
	135	.30	-	"
	140	.12	2.9	F3
	145	.12	2.9	"
	150	.13	2.8	"
	155	.15	2.4	"
	160	.18	1.9	"
	165	.20	1.45	"
	170	.21	1.10	"
	175	.30	0.85	"
	179.995	.35	0.70	"

Band - VHF (2) (set to 300Mhz)	Frequency	Sens (uV)	Power	Mode
	300	50/75	-	A3/F3
	320	4/20	-	"
	340	.3/.6	-	"
	360	.2/.5	-	"
	380	.2/.6	-	"
	400	.2/.75	-	"

Band - UHF	Frequency	Sens (uV)	Power	Mode
	400	11	1.0	F3
	410	4	1.5	"
	420	1	1.85	"
	430	.2	2.2	"
	435	.12	2.3	"
	440	.10	2.5	"
	445	.10	2.5	"
	450	.10	2.5	"
	455	.15	2.3	"
	460	.16	2.3	"
	465	.20	2.0	"
	470	.45	1.8	"
	480	1	1.6	"
	490	2	1.3	"
	500	6	1.1	"
	510	no RX over 509	0.8	"

This modification is read 1779 times.

[top of page](#)

19-07-1998

(TH-79) Cross Band Repeat

from Chuck Scott, N8DNX

The TH-79 does go into X-Band repeat. Press the "F" key then the "MONI" key to enter repeat mode. Use the same to return to normal.

There is a 10 min transmit limit so it's not useable for long duration monitoring of a continuous transmission. That's understandable in light of the number of horror stories I've heard of people frying their HT's in repeat mode.

This modification is read 1916 times.

[top of page](#)

03-01-1999

(TH-79) TH-79 Save function & packet!

From: OH2ZAZ@OH2RBI.FIN.EU

From some testing I've done it looks like it's necessary to set the SAVE mode on the TH-79's menu to OFF for proper packet radio operation.

When this function is ON, my PR system misses the first FBB UNPROTO updates after an update request (originating from my station) unless another packet arriving in between the request and the first UNPROTO packet 'wakes' up the TH-79.

If not woken up the RX seems to miss (some of) the first update packet and Winpack shows only the second and following, which generates repeated requests for an update of the message list. The updates go to the FBB Unproto buffer, but the BBS system keeps repeating them all over and over again including one final time when the first FBB UNPROTO update does happen to get registered and the buffer clears.

When I first got the TH-79, I measured current consumption and saw it going down during standby without a signal, then when a signal was received the current would go up and stay 'high' for a rather short while after the signal had disappeared and then it would go to sleep again. This behaviour is present when the SAVE mode is enabled. I assume the squelch is too slow for packet when the SAVE mode is enabled. (I need to have the squelch at position 4, btw, because of digital noise on 144,675 MHz.)

Does anybody else have the same experience with the TH-79 SAVE mode and the FBB UNPROTO updates?

tu es 73 de Arjen, OH2ZAZ@OH2RBI
Current QTH: Helsinki - KP20LD

This modification is read 1763 times.

[top of page](#)

Author: Jann DG8NGN - jann@gmx.de.MODIFICATION.NET

Hello TH79 fans.

Once again a new version (3.5) of my FAQ for the Kenwood handheld TH79. Have Fun. Modifications, tips and everything about the TH79 are welcome !

1.0 RX/TX expansion TH79 and diode configurations

TX/RX-Qrgs after the modification:

In the upper receiver/transmitter
(better use for 2 m)

```

RX: 118  -135 MHz (VHF) AM
      136  -173 MHz (VHF) FM
      300  -399 MHz (VHF) AM/FM
      410  -469 MHz (UHF) FM
TX: 136  -173 MHz (VHF) FM
      410  -469 MHz (UHF) FM

```

In the lower receiver/transmitter:
(better use for 70 cm)

```

RX: 124,6-173 MHz (VHF) FM
      410  -469 MHz (UHF) FM
      800  -999 MHz (UHF) FM
TX: 136  -173 MHz (VHF) FM
      410  -469 MHz (UHF) FM

```

The modifications have been done with the TH79E with the serial number 90200050.

Models with the serial number 60900100 and lower (memory skipping function F+L. OUT doesn't work) can use new frequencys like 67-117 RX, 400-409 RX/TX and 470-511 RX/TX. But the PLL doesn't work fine in that areas. The Frequencys are flashing in the display. Between 67 and 85 MHz there is no RX possible. So Kenwood decided to cancel the frequencyarea in the following models of the TH79. The microprocessor has been changed.

After the modification the TH79 have to be prograded again. To use the areas of 300-399 MHz and 800-999 MHz you have to push <F> + <LOW(HI/LO/EL)> (transmit power button) in the VFO mode at the corresponding reciever. After that you can store the frequencies.

1.1 preparation

- a . remove microphone, accumulator, antenna
- b . remove the screw at the direct current socket and the little screws on the back with a fitting screw driver.
- c . open the TH79 and put the front of the transmitter on the display.

1.2 modification

- a.remove the green wire near to the CTCSS socket.
- b.on the main board there are down on the right corner a row of a SMD resistance and 7 SMD diodes with missing 1 diode already. The diodes are labeled with an "A".
- c. Now you have to remove the third diode (D306) from the right end counted

Here's a little graphic:

```

Before:
R D - D D D D D |      R=resistance
  _____ |      D=diode
1 2 3 4 5 6 7 8 |      =nothing
Afterward:
R D - D D - D D |
  _____ |
1 2 3 4 5 6 7 8

```

- d. put together again and program the TH79 again :-)

1.3 diode configuration in other countrys

Modell	Area	Operat. range	Display range	Initial values				Tx-Rx unit no.
				Freq	Step	Offset	Tone	
TH79A-C	China	136-180 400-512		144M 430M	12.5k 25k	+ -5.7M + -10M	88.5 88.5	
TH79A-K	America	144-148 (118-174) 438-450	144-148 (118-174) 438-450	144M 440M	5k 25k	+ -0.6M + -5M	88.5 88.5	X57-4400-11
TH79A-K2	America rx-mod marse	142-152 (118-174) 420-450		144M 440M	5k 25k	+ -0.6M + -5M	88.5 88.5	
TH79A-K3	America tx-mod	136-180 (67-180) 400-512		144M 440M	5k 25k	+ -0.6M + -5M	88.5 88.5	
TH79A-K4	America rx-mod marse +add.	142-152 (67-180) 420-450 (400-512)		144M 440M	5k 25k	+ -0.6M + -5M	88.5 88.5	
TH79A-K5	America rx-mod +add.	144-148 (67-180) 438-450 (400-512)		144M 440M	5k 25k	+ -0.6M + -5M	88.5 88.5	
TH79A-X	Austral.	144-148 (118-174) 430-440	144-148 (67-180) 430-440	144M 430M	5k 25k	+ -0.6M + -5M	88.5 88.5	X57-4400-71
TH79E-E	Europe	144-146 430-440	144-146 430-440	144M 430M	12.5k 25k	+ -0.6M + -1.6M -7.6M	1750 1750	X57-4402-71
TH79E-E2	Italy	136-174 (118-174) 410-470	136-180 (67-180) 400-512	144M 430M	12.5k 25k	+ -0.6M + -1.6M -7.6M	1750 1750	X57-4402-72
TH79E-E3	England	144-146 430-440	144-146 430-440	144M 430M	12.5k 25k	+ -0.6M + -1.6M -7.6M	1750 1750	X57-4402-73
TH79E-E4		144-146 432-438		144M 432M	12.5k 25k	+ -0.6M + -1.6M	1750 1750	
TH79A-M	General	144-148 430-440	144-148 430-440	144M 430M	12.5k 25k	+ -0.6M + -5M	88.5 88.5	X57-4400-21
TH79A-M2	General	136-174 (118-174) 410-470	136-180 (67-180) 400-512	144M 430M	12.5k 25k	+ -0.6M + -5M	88.5 88.5	X57-4400-22

Diode:

3 3 3 3 3 3 3
0 0 0 0 0 0 0
2 3 4 5 6 7 8

C D D - D D - -
K D D D D - D D
K2 D D D D - D -
K3 D D - D - - D
K4 D D D D - - -
K5 D D D D - D -
X D - D D D - -
E D - D D D D D
E2 D - D D D D -
E3 D - D D D D D
E4 D - - D D D D
M D D - D D D D
M2 D D - D D D -

D = Diode
- = nothing

Changes between TH79E and TH79A

TH79E "Tone" = TH79A "Lamp"
TH79E "Lamp" = TH79A "Call Function"

1.4 Further diode configurations

general descripton of the seperate diodes

D302 Channel display mode

D303 -

D304 -

D305 Channel display mode and key lock

D306 Crossband repeater, answerback

D307 -

D308 Frequency extension

(Informations from Kenwood)

Removing of Diode:

D302 Takes modifictaion of point 3.0 in permanent duration

D305 activates additional key lock function of function in point 3.0

D308 corresponding the green wire near CTCSS-bush

Diode configuration for

RX: 118-173 MHz

300-399 MHz

410-469 MHz

800-999 MHz

TX: 144-146 MHz

430-440 MHz

That configuration is necessary in countrys where the ability to transmit outside amateur radio bands isn't allowed (e.g. netherlands)

R D - - D D D D		R = resistance
3 3 3 3 3 3 3 3		D = diode
0 0 0 0 0 0 0 0		- = nothing
1 2 3 4 5 6 7 8		

2.0 additional functions of the TH79 after the modification of point 1

2.1 Crossbandrepeater

With that function, the TH79 can work like a repeater.

It is only possible to cross frequencies from the UHF-RX to the VHF-TX or from the VHF-RX to the UHF-TX.

Just view the RX/TX list of point 1.

For activating the mode push <F>+<Moni>.

Switching off again with <Moni>. You should

choose the right TX-power before.

The TH79 stopps crossing, after 3 minutes sending all the time, not to damage the TH79.

The CTCSS-modul can be of use to select wanted signals.

2.2 Cloning

With that funtion it's possible to transfer the memory of the TH79 to antoher TH79. But you have to care, because only TH79s of the same diodeconfiguration can be cloned. For example you can't clone a TH79E with a TH79A. Maybe it's possible to save your memory on tape or so.

- Push PTT- and VFO-button during switching on.
(You need only to do that at the first time Cloning)
- Choose TX-Qrg and TX-Power
- Turn off
- Push 0 during switching on. CLONE appears on the display.
- Take other TH79 in Cloning mode.
- Push PTT at the sending TH79 and wait about 4-5 minutes
- After successful Cloning both TH79 displays END.
Recieving TH79 will display ERROR, if there has been any errors during transmission.

2.3 new menu items

- menu item 18 AnswerBack: ON/OFF
With this menu item it is possible to switch on/off the automatic confirmation of a pagingcall in the Pagemodus.
- menu item 19 FM/AM Mode: FM/AM
With this menu item you can toggle between AM- and FM- Mode in frequency area 300-399 MHz.

You can see the decimal line (4*2 pixels) in AM-Mode and the decimal point (2*2 pixels) in FM-Mode on the display between chosen frequency.

c. menu item 20 Prog VFO: 300-399

You can choose the VFO area between 300 and 399 MHz.

d. menu item 21 Prog VFO: 800-999

You can choose the VFO area between 800 and 999 MHz.

2.4 text messages

With the TH79 you're able to send and receive text messages.

Receiving:

The function DT(ss) or PAG(e) must be switched on to use this feature. On the display must PAG or DT appear.

Transmitting:

The message may not be longer than 6 signs and will be transferred by DTMF. Here's a conversion table:

0 = 0	Q = 1+A	Z = 1+B	= 1+C
1 = 1	A = 2+A	B = 2+B	C = 2+C
2 = 2	D = 3+A	E = 3+B	F = 3+C
3 = 3	G = 4+A	H = 4+B	I = 4+C
4 = 4	J = 5+A	K = 5+B	L = 5+C
5 = 5	M = 6+A	N = 6+B	O = 6+C
6 = 6	P = 7+A	R = 7+B	S = 7+C
7 = 7	T = 8+A	U = 8+B	V = 8+C
8 = 8	W = 9+A	X = 9+B	Y = 9+C
9 = 9			

You have to send out the message like this:

<DTSS- or PAGE-number of the receiver>#<message in DTMF>#

E.g.: DTSS or page number of the Receiver: 275

Message: "TEST" = 8A3B7C8A

Petition: 275#8A3B7C8A#

Of course the DTMF memory can be used for that, too.

I'll send a program to calculate the codes for the text messages from SQLBSE in the BBS.

You can test that feature with only one TH79 ! You can use the third harmonic wave for that test. The Duplex-mode (F+DUP) must be activated. Try it !

- E.g.:
1. Adjust 144.900 MHz on the upper TRX.
 2. Use only low transmit power or dummyload
 3. Adjust 434.700 MHz on the lower TRX.
 4. Activate Duplexmode (F+DUP)
 5. Activate DTSS on the lower receiver.
 6. Choose DT-code
 7. Reduce volume
 8. During transmitting with the upper TRX you have to enter e.g.: 275#8A3B7C8A#
 9. Now you'll be able to see the result on the display for the lower TRX.

3.0 Channel display mode

After activating that function the TH79 shows only the stored memories like that: CH (memorynumber). With that you're able to disable the free choice of frequencies and you can only use the stored memories. The function can be activated by pressing the BAND VxV, UxU button during switching the TH79 on.

4.0 (not tested yet)

5.0 sensitivity TH79

Results only have to be regarded as guide values.

Frequency [MHz] | performance [dBm] tension [uV]

Frequency [MHz]		performance [dBm]	tension [uV]
118	AM	-110	0.71
120	AM	-115	0.4
125	AM	-125	0.12
130	AM	-127	0.1
136	FM	-122	0.18
140	"	-126	0.11
145		-129	0.08
150		-129	0.08
155		-125	0.12

160		-122	0.18
165		-118	0.28
170		-116	0.35
173		-114	0.45
300	AM	-95	3.9
310	"	-109	0.8
320		-124	0.14
330		-128	0.09
340		-131	0.06
350		-135	0.04
360		-135	0.04
370		-136	0.04
380		-136	0.04
390		-136	0.04
399		-135	0.04
410	FM	-109	0.8
415	"	-116	0.35
420		-123	0.16
425		-126	0.11
430		-128	0.09
435		-128	0.09
440		-128	0.09
445		-127	0.1
450		-125	0.12
455		-122	0.18
460		-118	0.28
465		-114	0.45
469		-111	0.63
800	FM	-85	12.6
825	"	-90	7.1
850		-95	3.9
875		-100	2.2
900		-105	1.25
925		-110	0.71
950		-110	0.71
975		-110	0.71
999		-110	0.71

6.0 Modification TH79 for 2m/70cm 9K6/Pocsag/ACARS RX! TX? :

Well, a really difficult thing...

There will be no problems with receiving 9k6 signals or 512, 1200 or 2400 baud Pocsag signals. Further ACARS on the 2m band is no problem, too.

There will be problems with TX. Who has a better idea to solve the problems than my following ???

Depending on DIGI you have more or less success with 9K6-TX.

I have tested DB0ABH (about 15 km) and DB0ZB (about 80 km).

DB0ABH has only got every 20th frame, but DB0ZB every 1,5th.

Short Frames go quite speedy, but the longer ones are causing waiting for hours :-)

The TH79 tries to adjust the frequency during transmission :-)

But the TX-Delay of the TH79 is really great. You can choose are TX-Delay of 8-9.

DL1RNO Juri and I are developing a 2-Point modulation to solve that problem.

Are there any other ideas to solve that problem ???

Unfortunately, I couldn't test Pocsag TX yet.

For RX-Broadcast, of course it's a fine thing.

You can find the layouts for help in the BBS, too.

6.1 preparation

- Remove microphone, accumulator, antenna
- Remove the screw at the direct current socket and the little screws on the back with a fitting screw driver.
- Open TH79 and remove CTCSS cap
- Turn the front of TH79 on the display on the left side and the back on the right side
- For better working you have to remove the flat ribbon cable. Use a little screw driver for removing the cable out of its fastening. Now you can pull out the cable. After that you have to remove the red-black-yellow wire from the mainboard by hand.

6.2 RX-modification 70cm

- You have to solder the connection of the antenna socket away. antenna socket. Push the wire a bit away during soldering.

- a. There is a daughter board put on the main board in the TH79.
You have to pull the transparent foil over the board.
- b. The graphic shows you how to connect the TX feeding.

```

#run cable here
*-----#-----*
!           #           !
!  *--* *--*   #           !
!  !PO! !TI!   *-----*   # *-----* !
!  *--* *--*   !ATMEL707!   # ! LM301  !!
!  *--* *--*   *-----*   # *-----* !
!  !PO! !TI!   #           !
!  *--* *--*   #           !
!           #           !
!  *--*           #           !
!  !PO!           #           !
!  *--*           . . . .-c-*C*# <= solder !
!  *--*           ! TC7660 !           on here !
!  !TI!           *-----*           !
!  *--*           !           !
*-----#-----*

```

At the 5th pin (above at the right) of the IC TC7660 there are two capacitors in line. You have to solder on the cable at the second capacitor on the negativ pole.

6.5 Connection

- a. I have a good tip (if there's no CTCSS unit) to construct a connection without any cables hanging out of the TH79. Get a single-breasted socket strip and a containing fitting pin contact strip. Break out 2 pieces.
- b. Now you have to solder the cables with the socket strip. The cable must reach to the CTCSS slide-in.
- c. For better remembering mark RX or TX with color. Now you can stuck the socket strip on the board, but try to stuck it, so that the CTCSS cap can be still insert.
- d. Stuck a bit insulating tape on the socket strip, because maybe the sheet copper will contact the pins.
- e. Before using the 9k6 TX/RX feature you need only remove the CTCSS cap with the fingernail or a thin screw driver. The TH79 looks like before....

7.0 Repairing the TH79

7.1 Frequency regulator jumps ? Volume regulator scratches ?

You have to take the front of the TH79 apart to remove the regulators for processing.

- a. Remove microphone, accumulator, antenna
- b. Remove the screw at the direct current socket and the little screws on the back with a fitting screw driver.
- c. Open TH79 and remove CTCSS cap
- d. For better working you have to remove the flat ribbon cable. Use a little screw driver for removing the cable out of its fastening. Now you can pull out the cable. After that remove the plug between the regulators (cable: yellow, black, red). Now you can work with the front of the TH79 fine.
- e. Remove volume regulator cap and frequency regulator cap.
- f. Now you can remove the black cap on the top of the TH79.
- g. Remove sealing ring of the regulators.
- h. Nut of the regulators can be removed with a 10s fork key.
- i. Remove the golden 2 screws on the board.
- j. Push the metal over the regulators a bit up and lift the board a bit up. Push the microphone ports a bit to the side during pulling the board up. Attention: Don't lose the LOCK-Key.
- k. Now pull the plastic (under the plastic is the keypad) at the fastenings for the board up and take it away. After that you'll have the front board incl. display in your hand.
- l. Then you have to solder off the regulators with its mini boards from the main board. Okay, now you have the regulators incl. mini boards in your hand.

7.1.1 The frequency regulator

The clamping ring below the frequency regulator must be removed.

Attention: Clamping rings are perhaps jumping far away.

Now you can take the inner pin out and remove the dirt with e.g. a cloth. (my pin was a bit black).

Then you have to use contact spray to clean the regulator.

Put the pin back again and remove it again. Repeat that as long as it will be clean enough. Now the regulator will not jump any longer (hope so)
Be carefully when you solder the regulator back again.

7.1.2 The volume regulator

Pull up the pin of the regulator to use contact spray. Rotate the regulator during using contact spray. You can use it on the lower side of the regulator, too. After that the regulator will not scratch any more. Be carefully when you solder the regulator back again.

7.2 Dust behind the display? Buttons don't work?

Open the TH79 like in point 6.1 described. Now you can easily wipe the display off with a cloth and freeing the TH79 from dust inside. Alternatively you can also open the display at the sides with a little screwdriver, although the TH79 is shut. You can simply clean the Keypad with soap and water. Often dust or grease under the buttons prevent contacts.

7.3 Scratched display?

Try "acrylic glass & repair" paste for doing this job. There's no matter to polish the inner LCD-Display heavier. After this the TH79 looks as new ...

7.4 funny behaviour of the TH79 ?

2m TX doesn't work ? Squelch all the time open ? Maybe it's the flat cable between the two main boards ! On the ends of the cable there can be no contact an more :-(Just try to cut the cable at the ends and sand it a bit. Maybe it works again. It's not very expensive, when you want a new cable from Kenwood.

7.5 voltage error ?

Maybe the contact between the daughter board an the main board isn't correct. Okay, don't wonder, when you use your TH79 with 20 volts :-)

7.6 display contrast problems ?

There are often contact problems between the main board and the display. To fix the problem fasten the screws at the backside of the display. Now the display should work again. You can lock the screws with some nail-paint for example.

8.0 technical Information

8.1 Transmitpower of the TH79

12V DC:
VHF up to 5,0 watts
UHF up to 3,5 watts

6V DC (600mAh Akkupack PB-32)
VHF up to 2,5 watts
UHF up to 2,0 watts

8.2 TOT-function

After 10 minutes sending all the time the TH79 stopps sending because of the heath. The function is included in the micro-processor and can't be deactivatet :-(With the older TH79s (see 1.0) it's possible to activate the 10 minutes TX function. Press VFO- or MR-button till the beep and press now while holding the VFO- or MR-button the PTT-button. Function is activated.

Who needs Infos from the service manual of the TH79 ?
I've got it ! Just E-mail me for further Information.

Tips and tricks pse to DG8NGN @DB0ABH.#BAY.DEU.EU or JANN @GMX.DE

Special Thanks to SQ1BSE Pawel, DD1JD Dirk, DL1RNO Juri and DF9ZR Peter

73 and 55
Jann from Nuremberg

28-10-2001**(TH-79) DTMF-based message translator****Author:** SQ1BSE[DTMF-based](#) message translator for TH-79E HT

Developed using Amiga by SQ1BSE

29-10-2001**(TH-79) TH-79 FAQ 3.5 by DG8NGN****Author:** DG8NGN - jann@gmx.de.MODIFICATION.NET

Hallo TH79-Fans.

Hier mal wieder eine neue Version (3.5) der FAQ für das Kenwood Handfunkgerät TH79. Viel Spaß. Anregungen, Verbesserungen und Modifikationen sind sehr erwünscht...

1.0 RX/TX-Erweiterung und Diodenkonfigurationen

max. TX/RX-Qrgs nach der folgenden Modifikation:

Im oberen Empfänger/Sender
(besser für 2m geeignet)

RX:	118	-135 MHz	(VHF)	AM
	136	-173 MHz	(VHF)	FM
	300	-399 MHz	(VHF)	AM/FM
	410	-469 MHz	(UHF)	FM
TX:	136	-173 MHz	(VHF)	FM
	410	-469 MHz	(UHF)	FM

Im unterem Empfänger/Sender:
(besser für 70cm geeignet)

RX:	124,6-173 MHz	(VHF)	FM	
	410	-469 MHz	(UHF)	FM
	800	-999 MHz	(UHF)	FM
TX:	136	-173 MHz	(VHF)	FM
	410	-469 MHz	(UHF)	FM

Die Modifikationen wurden am TH79E mit der Seriennummer 90200050 gemacht.

Bei Modellen mit der Seriennummer 60900100 (Speicherüberspringfunktion F + L.OUT geht nicht) und darunter wird der Bereich 67-179 RX, 400-511 RX/TX verfügbar. Allerdings rastet die PLL unter etwa 88 MHz schon nicht mehr. Nicht zu vergessen ist, dass eh alles unter 118 MHz nur als AM zu empfangen ist. Ein Arbeiten in diesem zusätzlichen Bereich ist kaum möglich und wurde daher in der nächsten Generation des TH79 gleich weggelassen. Der Mikroprozessor wurde gewechselt.

Nach der Modifikation muß das Gerät neu programmiert werden. Um nun in die Bereiche 300-399 MHz und 800-999 MHz zu kommen, muss man am entsprechenden Empfänger <F> + <LOW(HI/LO/EL)> (Sendeleistungsknopf) im VFO-Modus drücken. Danach können in diesem Bereich die Frequenzen abgespeichert werden.

1.1 Vorbereitung

- a. Mikrofon, Akku, Antenne entfernen
- b. Schraube an der Gleichstrombuchse und die kleinen Schrauben auf der Rückseite mit einem passenden Kreuzschlitzschraubendreher entfernen
- c. Gerät öffnen und Vorderseite des Gerätes auf das Display legen

1.2 Umbau

- a. Den grünen Draht nahe CTCSS-Buchse entfernen
- b. Auf der Hauptplatine befinden sich unten rechts in der Ecke in einer Reihe ein SMD-Widerstand und 7 SMD-Dioden mit der Aufschrift "A", wo bereits eine fehlt.
- c. Jetzt muss die dritte Diode (D306) von rechts aus entfernt werden.

Hier eine kleine Grafik:

vorher:

```

R D - D D D D D |
-----|
 3 3 3 3 3 3 3
 0 0 0 0 0 0 0
1 2 3 4 5 6 7 8

```

R = Widerstand
D = Diode
- = nichts

nachher:

```

R D - D D - D D |
-----|
 3 3 3 3 3 3 3
 0 0 0 0 0 0 0
1 2 3 4 5 6 7 8

```

- d. Gerät wieder zusammenbauen und neu programmieren :-)

1.3 Länderspezifische Diodenkonfigurationen

Modell	Area	Operat. range	Display range	Initial values			Tx-Rx unit no.	
				Freq	Step	Offset Tone		
TH79A-C	China	136-180 400-512		144M 430M	12.5k 25k	+-5.7M +-10M	88.5 88.5	
TH79A-K	America	144-148 (118-174) 438-450	144-148 (118-174) 438-450	144M 440M	5k 25k	+-0.6M +-5M	88.5 88.5	X57-4400-11
TH79A-K2	America rx-mod marse	142-152 (118-174) 420-450		144M 440M	5k 25k	+-0.6M +-5M	88.5 88.5	
TH79A-K3	America tx-mod	136-180 (67-180) 400-512		144M 440M	5k 25k	+-0.6M +-5M	88.5 88.5	
TH79A-K4	America rx-mod marse +add.	142-152 (67-180) 420-450 (400-512)		144M 440M	5k 25k	+-0.6M +-5M	88.5 88.5	
TH79A-K5	America rx-mod +add.	144-148 (67-180) 438-450 (400-512)		144M 440M	5k 25k	+-0.6M +-5M	88.5 88.5	
TH79A-X	Austral.	144-148 (118-174) 430-440	144-148 (67-180) 430-440	144M 430M	5k 25k	+-0.6M +-5M	88.5 88.5	X57-4400-71
TH79E-E	Europe	144-146 430-440	144-146 430-440	144M 430M	12.5k 25k	+-0.6M +-1.6M -7.6M	1750 1750	X57-4402-71
TH79E-E2	Italy	136-174 (118-174) 410-470	136-180 (67-180) 400-512	144M 430M	12.5k 25k	+-0.6M +-1.6M -7.6M	1750 1750	X57-4402-72
TH79E-E3	England	144-146 430-440	144-146 430-440	144M 430M	12.5k 25k	+-0.6M +-1.6M -7.6M	1750 1750	X57-4402-73
TH79E-E4		144-146 432-438		144M 432M	12.5k 25k	+-0.6M +-1.6M	1750 1750	
TH79A-M	General	144-148 430-440	144-148 430-440	144M 430M	12.5k 25k	+-0.6M +-5M	88.5 88.5	X57-4400-21
TH79A-M2	General	136-174 (118-174) 410-470	136-180 (67-180) 400-512	144M 430M	12.5k 25k	+-0.6M +-5M	88.5 88.5	X57-4400-22

Diode:

3 3 3 3 3 3 3
0 0 0 0 0 0 0
2 3 4 5 6 7 8

C D D - D D - -
K D D D D - D D
K2 D D D D - D -
K3 D D - D - - D
K4 D D D D - - -
K5 D D D D - D -
X D - D D D - -
E D - D D D D D
E2 D - D D D D -
E3 D - D D D D D
E4 D - - D D D D
M D D - D D D D
M2 D D - D D D -

D = Diode
- = nichts

Änderungen zwischen TH79E und TH79A

TH79E "Tone" = TH79A "Lamp"
TH79E "Lamp" = TH79A "Call Function"

1.4 Weitere Diodenkonfigurationen

Allgemeine Beschreibung der einzelnen Dioden:

D302 Channel display mode
D303 -
D304 -
D305 Channel display mode and key lock
D306 Crossband repeater, answerback
D307 -
D308 Frequency extension
(Informationen von Kenwood)

Entfernen der Diode:

D302 erhält die Funktion unter 3.0 beschrieben dauerhaft
D305 aktiviert zusätzlich zur unter 3.0 beschriebenen Funktion
die Tastensperre
D308 entspricht dem grünen Draht nahe CTCSS-Buchse

Diodenkonfiguration für

RX: 118-173 MHz
300-399 MHz
410-469 MHz
800-999 MHz
TX: 144-146 MHz
430-440 MHz

Diese Konfiguration wird in Ländern benötigt, die die
TX-Modifikation ausserhalb des Amateurfunkbereiches nicht
erlauben. (z.B. Niederlande)

R D - - D D D D		R = Widerstand
3 3 3 3 3 3 3		D = Diode
0 0 0 0 0 0 0		- = nichts
1 2 3 4 5 6 7 8		

2.0 zusätzliche Funktionen des Gerätes nach der Modifikation von Punkt 1

2.1 Crossbandrepeater

Mit der Crossbandrepeaterfunktion ist es möglich
das Eingangssignal auf einer anderen Frequenz auto-
matisch wieder auszusenden.

Beim Crossbandbetrieb ist es nur möglich Frequenzen
vom UHF-RX zum VHF-TX oder vom VHF-RX zum UHF-TX zu
crossen. Zu Beachten ist die RX/TX-Liste von Punkt 1.

Zum Aktivieren des Modus muss <F>+<Moni> gedrückt
werden. Abschalten mit <Moni>. Vorher sollte
man die gewünschte TX-Leistung einstellen.
Wenn der TH79 länger als 3 Minuten dauersendet beim Crossen,
dann schaltet die Crossbandrepeaterfunktion sicherheitshalber ab.

Das CTCSS-Modul kann zum Selektieren des zu crossende Signals

verwendet werden.

Crossbandrepeaterbetrieb in EINE Richtung:

Wenn das VHF-Band für TX gesperrt werden soll, dann muß man auf dem VHF-Band ein Memoryspeicher mit der VHF-RX-Frequenz abgespeichert werden und eine exotische Ablage in den AM-Frequenzbereich 118-136 MHz programmiert werden. Alternativ kann auch im Menü die Standard-Ablage für den VHF-Bereich auf 99,95 gestellt werden und die Standardablage aktiviert werden.

Wenn das UHF-Band für TX gesperrt werden soll, dann muß man die Standardablage auf 99,95 stellen und auf der RX-Frequenz aktiviert werden.

2.2 Clonen

Mit der Cloningfunktion ist es möglich den gesamten Speicher des TH79 zu einem anderem TH79 zu übertragen. Dabei ist darauf zu achten, dass beide TH79 die gleichen Modifikationen besitzen, also es kann z.B. kein TH79A auf den TH79E oder ein TH79E mit RX-Erweiterung auf einen normalen TH79E geclont werden. Angeblich soll sogar eine Sicherung auf Tonband funktionieren. Die Sendeleistung wird beim Clonen automatisch auf Stufe EL beschränkt.

- a. Während dem Einschalten PTT und VFO drücken
(wird nur beim ersten Mal "Clonen" benötigt um den Prozessor zu programmieren)
- b. Sendefrequenz auswählen
- c. Ausschalten
- d. Während dem Einschalten 0 drücken. CLONE erscheint im Display
- e. Partnergerät in den Clonemodus bringen
- f. Beim Sendegerät kurz PTT drücken und ca. 4-5 Minuten warten
- g. Bei erfolgreichem Clonen zeigen beide Geräte im Display END an. Bei einem Fehler erscheint ERROR beim Empfängergerät.

2.3 neue Menüpunkte

- a. Menüpunkt 18 AnswerBack: ON/OFF
Mit diesem Menüpunkt ist es möglich die automatische Rückbestätigung eines Pagerufes im Pagemodus ein- bzw. auszuschalten.
- b. Menüpunkt 19 FM/AM Mode: FM/AM
Mit diesem Menüpunkt kann man zwischen AM- und FM-Modus im Bereich 300-399 MHz umschalten.
Im AM-Modus ist der Dezimalstrich (4*2 Pixel) und im FM-Modus der Dezimalpunkt (2*2 Pixel) zwischen der eingestellten Frequenz zu sehen.
- c. Menüpunkt 20 Prog VFO: 300-399
Hier kann der VFO-Bereich für das Gerät zwischen 300 und 399 MHz eingestellt werden.
- d. Menüpunkt 21 Prog VFO: 800-999
Hier kann der VFO-Bereich für das Gerät zwischen 800 und 999 MHz eingestellt werden.

2.4 Textnachrichten

Mit dem TH79 ist es möglich zu einem anderen TH79 Textnachrichten zu verschicken:

Empfang:

Das Gerät muss im DT(ss) oder PAG(e)-Modus stehen.
Die Anzeige DT bzw. PAG muss im Display angezeigt werden.

Senden:

Die Nachricht darf nicht länger als 6 Zeichen sein und wird per DTMF übertragen. Hierzu folgende Umrechnungstabelle:

0 = 0	Q = 1+A	Z = 1+B	= 1+C
1 = 1	A = 2+A	B = 2+B	C = 2+C
2 = 2	D = 3+A	E = 3+B	F = 3+C
3 = 3	G = 4+A	H = 4+B	I = 4+C
4 = 4	J = 5+A	K = 5+B	L = 5+C
5 = 5	M = 6+A	N = 6+B	O = 6+C
6 = 6	P = 7+A	R = 7+B	S = 7+C
7 = 7	T = 8+A	U = 8+B	V = 8+C
8 = 8	W = 9+A	X = 9+B	Y = 9+C

9 = 9

So wird die Nachricht verschickt:

<DTSS- oder PAGE-Nummer des Empfängers>#<Nachricht in DTMF>#

z.B.: DTSS- oder PAGE-Nummer des Empfängers: 275

Nachricht: "TEST" = 8A3B7C8A

Eingabe: 275#8A3B7C8A#

Der DTMF-Speicher kann natürlich dafür genutzt werden.

Zum Berechnen dieser Textnachrichten füge ich ein DOS-Programm von SQLBSE am Ende der FAQ mit ein.

Zum Ausprobieren und Testen mit nur einem Gerät kann ich empfehlen die 3 Oberwelle im Duplexmodus (F + DUP) auszuprobieren.

- z.B.:
1. Oben 144,900 MHz einstellen
 2. Geringe Sendeleistung oder Dummyload verwenden
 3. Unten 434,700 MHz einstellen
 4. Duplexmodus aktivieren (F+DUP)
 5. Unten DTSS aktivieren
 6. Unten DT-Code einstellen
 7. Unten Volume runterdrehen
 8. Oben während dem Senden z.B.: 275#8A3B7C8A# eingeben
 9. Das Ergebnis müsste man nun im unterem Displayteil sehen können.

Dadurch wird es auch möglich auf die schon empfangen Nachrichten nochmal zuzugreifen, wenn man sie versehentlich durch z.B. Drücken der PTT-Taste übersehen hat.

Der Empfangspuffer speichert bis zu 10 Nachrichten und kann mit dem Frequenzdrehregler durchgesehen werden. Beim Ausschalten des Gerätes gehen alle Nachrichten verloren.

3.0 Channel Display Mode

Nach Aktivierung dieser Funktion zeigt das TH79 nur noch die abgespeicherten Speicher mit CH <Speichernummer>. Dadurch wird die freie Wahl der Frequenz gesperrt und man kann nur noch die abgespeicherten Frequenzen benutzen. Die Funktion kann man durch Einschalten des Gerätes mit gleichzeitigem Drücken der BAND VxV, UxU Taste aktivieren.

4.0 Fernsteuerung des TM-732 oder TM-742 über den TH79

Wer schreibt eine Beschreibung der Fernsteuerung für diese FAQ ? Ich habe leider keines der beiden Geräte. Die Application Notes darüber können von mir im JPG-Format bezogen werden oder vom Kenwood FTP-Server ftp.kenwood.net heruntergeladen werden.

5.0 Empfindlichkeit TH-79E

Werte sind nur als Richtwerte zu betrachten.

Frequenz [MHz] | Leistung [dBm] Spannung [uV]

118	AM	-110	0.71
120	AM	-115	0.4
125	AM	-125	0.12
130	AM	-127	0.1
136	FM	-122	0.18
140	FM	-126	0.11
145	FM	-129	0.08
150	FM	-129	0.08
155	FM	-125	0.12
160	FM	-122	0.18
165	FM	-118	0.28
170	FM	-116	0.35
173	FM	-114	0.45
300	AM	-95	3.9
310	AM	-109	0.8
320	AM	-124	0.14
330	AM	-128	0.09
340	AM	-131	0.06
350	AM	-135	0.04
360	AM	-135	0.04
370	AM	-136	0.04

380	AM	-136	0.04
390	AM	-136	0.04
399	AM	-135	0.04
410	FM	-109	0.8
415	FM	-116	0.35
420	FM	-123	0.16
425	FM	-126	0.11
430	FM	-128	0.09
435	FM	-128	0.09
440	FM	-128	0.09
445	FM	-127	0.1
450	FM	-125	0.12
455	FM	-122	0.18
460	FM	-118	0.28
465	FM	-114	0.45
469	FM	-111	0.63
800	FM	-85	12.6
825	FM	-90	7.1
850	FM	-95	3.9
875	FM	-100	2.2
900	FM	-105	1.25
925	FM	-110	0.71
950	FM	-110	0.71
975	FM	-110	0.71
999	FM	-110	0.71

6.0 Umbau TH79 für 2m/70cm 9K6/Pocsag/ACARS RX ! TX ? :

Tja, ein recht schwieriges Kapitel...

Mit RX hat man beim TH79 keine Probleme. Das funktioniert einwandfrei. Pocsag 512, 1200 und 2400 Baud ist auch kein Problem. ACARS auf der Frequenz 131,725 MHz sollte auch gehen.

Bei TX gibt es allerdings Probleme. Wer hierzu eine bessere Lösung als folgende hat, der möchte diese doch preisgeben. Je nach DIGI hat man mehr oder weniger Erfolge mit 9k6-TX. Ich habe DB0ABH (ca. 15 KM) und DB0ZB (ca. 80 KM) getestet. Bei DB0ABH kam jedes 20te und bei DB0ZB jedes 1,5te Frame an. Das ganze ist eher ein Glücksspiel, ob es geht oder nicht. Meist gehen kurze Frames recht zügig, doch bei längeren Frames versucht der TH79 die Frequenz nachzuregulieren :- (Hat jemand ein Idee was man da machen könnte ??? Die PLL des TH79 ist recht schnell, so dass TX-Delay von 8-9 im PR-Betrieb ohne weiteres möglich ist. DL1RNO (Juri) und ich sind zur Zeit daran eine 2-Punktmodulation für das Gerät zu realisieren. Die zwei extra verschiedenen 9k6-Modi des TNC2Multi müsste das Gerät aber auch so ohne Probleme mitmachen... Pocsag TX konnte ich leider noch nicht testen.

Für RX-Broadcast ist das natürlich eine feine Sache. Viel Erfolg beim Umbau.

Als Hilfestellung spiel ich auch noch das Platinenlayout für den Umbau mit ein.

6.1 Vorbereitung

- Mikrofon, Akku, Antenne entfernen
- Schraube an der Gleichstrombuchse und die kleinen Schrauben auf der Rückseite mit einem passenden Kreuzschlitzschraubendreher entfernen
- Gerät öffnen und CTCSS-Kappe entfernen (falls kein CTCSS-Modul vorhanden)
- Vorderseite des Gerätes auf das Display auf die linke Seite legen und die Rückseite auf die rechte Seite legen.
- Zum besseren Arbeiten muss das Flachbandkabel (recht empfindlich) auf der links liegenden Geräteseite ausgesteckt werden. Dazu mit einem kleinen Schlitzschraubendreher an den Seiten der Kabelbefestigung das braune Befestigungsteil nach oben hebeln. Jetzt kann das Kabel herausgezogen werden. Danach muss man noch die Stromversorgung rot-schwarz-gelbes Kabel aus der Buchse herausziehen.

6.2 RX-Modifikation 70cm

- Auf der rechts liegenden Seite befindet sich eine schwarze Plastikummantelung um die Antennenbuchse herum. Zum Entfernen der Plastikummantelung hebt man entweder den Dichtungsring um die Buchse herum heraus, oder wendet mehr Kraft beim Herausziehen an.

Vorher sollte man vielleicht ein bisschen die Schaumstoffbefestigung abziehen.

- b. Jetzt müssen die beiden Schrauben der Antennenbuchse entfernt werden. Danach kann die Antennenbuchse recht leicht weggelötet werden. Vielleicht dazu den Draht während dem Lötten etwas nach links drücken.
- c. Jetzt können die 5 Schrauben vom Kupferblech entfernt werden. (vielleicht versteckt sich mal wieder eine Schraube unter dem Schaumstoff oder unter dem Flachbandkabel :-))
Jetzt kann man die Platine von der Rückwand des Gehäuses trennen.
- d. Des weiteren betrachten wir die Unterseite der entnommenen Platine. Die Entnahme des RX-Signals erfolgt am IC MC3372D (16-beinig) von Motorola (UHF-Demodulator). Das RX-Kabel wird dort am Pin 9 (ganz oben rechts vom IC) angelötet. Das Kabel kann man am geschicktesten wie gefolgt auf die andere Seite gebracht werden. Hier eine kleine Grafik zur Verdeutlichung:

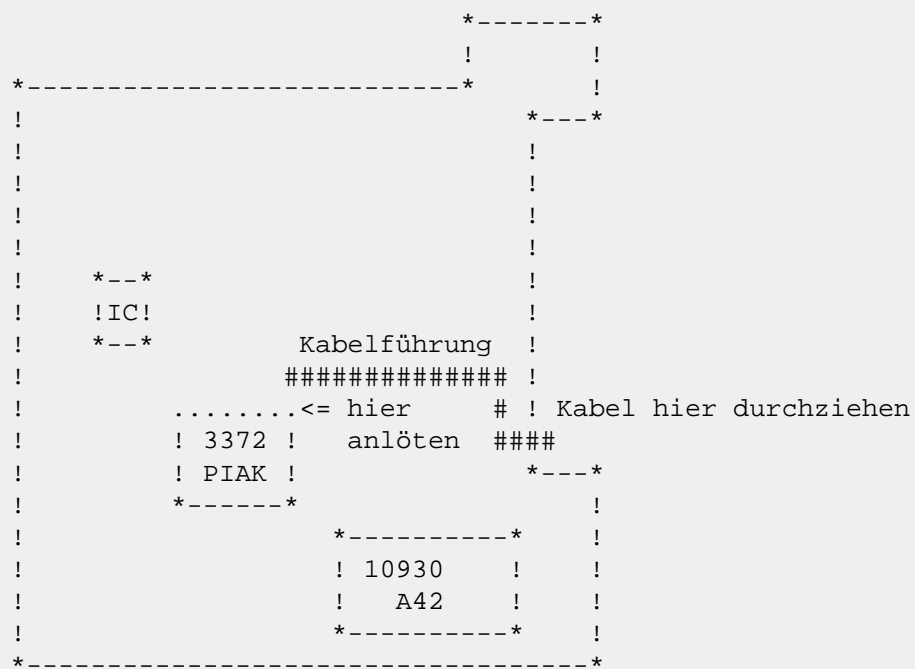

- e. Ist das Kabel auch nicht zu kurz ??? Jetzt kann diese Seite wieder zusammengebaut werden. Vergesst den Antennenanschluss nicht :-)

6.3 RX-Modifikation 2m

- a. Auf der rechts liegenden Seite des Gerätes befindet sich die Antennenbuchse. An dieser Buchse muss der Anschluss weggelötet werden. Dazu muss der Draht während dem Lötten nach links gedrückt werden.
- b. Jetzt kann die schwarze Plastikummantelung um die Antennenbuchse herausgenommen werden. Dazu hebt man entweder den Dichtungsring um die Buchse herum heraus, oder wendet mehr Kraft beim Herausziehen an. Vorher sollte man vielleicht ein bisschen die Schaumstoffbefestigung abziehen.
- c. Jetzt müssen die beiden Schrauben der Antennenbuchse entfernt werden. Danach die 5 Schrauben vom Kupferblech entfernen. (vielleicht versteckt sich mal wieder eine Schraube unter dem Schaumstoff oder unter dem Flachbandkabel :-))
Jetzt kann man die Platine von der Rückwand des Gehäuses trennen.
- d. Des weiteren betrachten wir die Unterseite der entnommenen Platine. Die Entnahme des RX-Signals erfolgt am IC TK10930V (24-beinig,VHF-Demodulator). Das RX-Kabel wird dort am Pin 12 (ganz unten rechts) vom IC angelötet. Das Kabel kann man am geschicktesten wie gefolgt auf die andere Seite gebracht werden. Hier eine kleine Grafik zur Verdeutlichung:

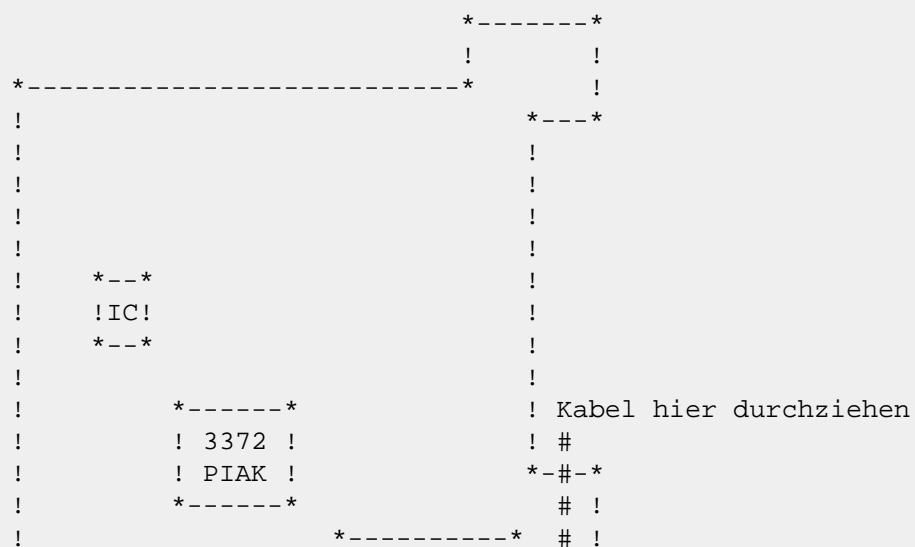

```

!           !   10930  !### !
!           !     A42  !#   !
!           !.....# <=!hier anlöten
*-----*

```

- e. Ist das Kabel auch nicht zu kurz ??? Jetzt kann diese Seite wieder zusammengebaut werden. Vergesst den Antennenanschluss nicht :-)

6.4 TX-Modifikation 2m/70cm

- a. Auf der links liegenden Seite des Gerätes befindet sich eine aufgesteckte Tochterplatine. Die darauf aufgeklebte Durchsichtsfolie muss abgezogen werden.
- b. Wer auf der kleinen Platine nicht im Gerät löten will, der kann die Platine auch aus der Fassung herausziehen, nachdem man den kleinen Stift unten rechts an der Platine abgelötet hat. Ich habe wieder eine kleine Grafik vorbereitet.

```

                                     #Kabel so verlegen
*-----*-----#-----*
!                                     #           !
!  *--* *--*                         #           !
!  !PO! !TI!   *-----*               # *-----* !
!  *--* *--*   !ATMEL707!              # ! LM301  !!
!  *--* *--*   *-----*               # *-----* !
!  !PO! !TI!                         #           !
!  *--* *--*                         #           !
!                                     #           !
!   *--*                             #           !
!   !PO!                             #           !
!   *--*                             #           !
!   *--*   . . . .-c-*C*# <= hier    !
!   *--*   ! TC7660 !                 anlöten !
!   !TI!   *-----*                 !
!   *--*                             !
*-----*-----*

```

Am 5ten Pin (oben rechts) des ICs TC7660 geht eine Leiterbahn an einen kleineren Kondensator. Danach gehts auf gleicher Höhe zum großen Kondensator C332. Dort erfolgt die TX-Einspeisung am negativen Pol (nach dem Kondensator). Dann kann das Kabel verlegt werden und die Klarsichtfolie wieder daraufgedrückt werden.

6.5 Anschluß

- a. Für den Anschluß wird es kein Patentrezept geben, aber ich habe einen guten Tip (wenn kein CTCSS-Modul vorhanden ist), wie man den Anschluß realisieren kann, ohne das Kabel rumhängen :-). Man besorge sich eine einreihige Buchsenleiste und eine passende Stiftleiste. Jeweils 2 bzw. 3 Stück herausbrechen.
- b. Jetzt verlötet man das RX/TX-Kabel mit dem Buchsenpaar so, dass das Kabel bis Höhe CTCSS-Einschub langt.
- c. Am besten markiert man sich mit Farbe die RX- oder TX-Buchse. Nun wird auf der links liegenden Seite das Buchsenpaar so auf die Platine geklebt, dass die CTCSS-Kappe noch reinpasst.
- d. Es sollte vielleicht noch ein Stück Isolierband auf das Buchsenstück geklebt werden, damit beim Zusammenbauen das Kupferblech nicht die Buchsen berührt.
- e. Vor dem 9k6-Betrieb kann jetzt ganz einfach die Kappe mit dem Fingernagel herausgehoben werden und das Handy schaut aus wie vorher :-)

7. Reperatur des Gerätes

7.1 Frequenzdrehregler springt ? Volumeregler kratzt ?

Hierzu muss die vordere Seite des TH79 zerlegt werden um die Regler für die Bearbeitung auszubauen.

- a. Mikrophon, Akku, Antenne entfernen
- b. Schraube an der Gleichstrombuchse und die kleinen Schrauben auf der Rückseite mit einem passenden Kreuzschlitzschraubendreher entfernen
- c. Gerät öffnen und CTCSS-Kappe entfernen (falls kein CTCSS-Modul vorhanden)
- d. Zum besseren Arbeiten muss das Flachbandkabel auf der links liegenden Geräteseite ausgesteckt werden. Dazu mit einem kleinen Schlitzschraubendreher an den Seiten der Kabelbefestigung das braune Befestigungsteil nach oben hebeln. Jetzt kann das Kabel herausgezogen werden. Danach noch den Stecker zwischen den Reglern (Kabel: gelb, schwarz, rot) wegziehen. Jetzt

- kann man wunderbar mit der Vorderseite des TH79 arbeiten.
- e. Volumeregler und Frequenzdrehregler abziehen.
- f. Jetzt kann die aufgesteckte Kappe oben abgezogen werden.
- g. Dichtungsring der Regler abziehen
- h. Muttern der Regler mit einem 10er Gabelschlüssel entfernen.
- i. Platinenbefestigung durch lösen der goldenen 2 Schrauben (über der 2,5mm Buchse und auf gleicher Höhe neben dem IC) entfernen.
- j. Blech über den Reglern ein bisschen nach oben drücken und die Platine ein Stück anheben. Mikrofonanschlußbuchsen klein wenig nach außen drücken und Platine ein Stück nach oben hochziehen. Ja, der Gummiblock für PTT, Tone und Moni muss nicht extra entfernt werden. Es klappt auch so.
Achtung: Tastenlockschieber kann leicht rausfallen !
- k. Jetzt das Plastik, unter dem sich der Tastenblock befindet, an den Befestigungen für die Platine nach oben ziehen und herausnehmen. Jetzt müsste man die Vorderplatine incl. Display in der Hand haben.
- l. Danach müssen die Regler deren Miniplatinen aus der Hauptplatine entlötet werden. Passt dabei auf die Leiterbahnen auf der Hauptplatine auf. Die lösen sich recht schnell ab. Am besten Entlötlitze benutzen. Ich hoffe ihr habt die Regler jetzt lose in der Hand

7.1.1 Der Frequenzdrehregler

Der Klemmring unten am Regler muß entfernt werden. Achtung: So ein Ring springt gerne weit weg. Danach kann der innere Stift herausgenommen werden und mit einem Tuch sauber gemacht werden (bei mir war er ein bisschen schwarz). In den Regler sprüht man genügend Kontaktspray hinein und steckt den Stift wieder rein. Danach so oft wiederholen, bis kein schwarzer Dreck mehr zu sehen ist. Nach dieser Aktion sollte der Drehregler nicht mehr springen. Beim Einbau sollte man auf die Lötstellen, die recht nah aneinander liegen, achten !!
Vor dem Zusammenschrauben des Gerätes vielleicht mal Punkt 7.2 druchlesen.

7.1.2 Der Volumeregler

Den Stift des Reglers muß man nach oben ziehen und in die winzige Lücke das Kontaktspray reintröpfeln lassen. Dabei den Regler immer drehen, damit die Flüssigkeit hineinlaufen kann. Man kann noch versuchen auf der Rückseite etwas hineinlaufen zu lassen. Nach dieser Aktion sollte der Volumeregler nicht mehr kratzen. Beim Einbau sollte man auf die Lötstellen, die recht nah aneinander liegen, achten !!
Vor dem Zusammenschrauben des Gerätes vielleicht mal Punkt 7.2 druchlesen.

7.2 Staub hinter dem Display ? Tasten funktionieren nicht ?

Am besten das Gerät wie in Punkt 6.1 beschrieben öffnen. Man kann jetzt leicht das Display mit einem Tuch abwischen und das Gerät innen von Staub befreien. Alternativ kann man auch das Display an den Seiten mit einem kleinen Schraubendreher heraushebeln. Das Keypad kann man einfach mit Seife und Wasser abwaschen. Meist steht viel Staub bzw. Fett unter den Tasten, das den Kontakt verhindern kann.

7.3 Verkratztes Display ?

Probiert einfach eine Acrylglas Polier&Repair Paste aus. Selbst die innere LCD-Anzeige hält stärkeren Druck beim Polieren aus, falls diese auch verkratzt sein sollte. Schaut danach wie neu aus...

7.4 seltsames Verhalten des TH79 ?

Tja, jetzt schmeisst doch nicht gleich euren TH79 weg ! Ich war auch schon am verzweifeln und habe festgestellt, dass sich der TH79 sehr komisch verhält (sendet nicht auf 2m, sendet gar nicht, tut so als würde er senden usw...), wenn das innere Flachbandkabel beschädigt ist. Meistens ist an den Enden die Knickstelle die Ursache für das Übel. Dort fehlt der Kontakt im Kabel, aber man kann sich z.B. durch Abschneiden des Kabels an dieser Stelle und folgendem Abschleifen der Isolierung helfen. Als Ersatzteil kann man es auch für ca. 20 Märker nachbestellen.

7.5 Voltage Error im Display ?

Schaut mal nach, ob der Kontakt von der Tochterplatine zur Mutterplatine noch in Ordnung ist.
Natürlich kann es auch sein, dass der TH79 zuviel Spannung bekommt.

7.6 Displaykontrastprobleme ?

Meistens gibt es Kontaktschwierigkeiten zwischen dem LCD-Display und den entsprechenden Leiterbahnen.
Zur Lösung des Problem einfach die kleinen Kreuzschlitzschrauben an der Leiterplatte unter dem Display ein bisschen nachziehen. Dadurch werden die Kontaktschwierigkeiten des Display-Leitgummis mit der Leiterplatte behoben.
Evtl. kann man noch Schraubenfestiger oder Nagellack auf Schrauben schmieren, dass sie sich nicht wieder lösen.

7.7 Lebensdauer des Akkupacks vorbei ?

Hier eine Version von DL1RNO Juri:

Wechsel der Akkus im Akkupack PB-32

Mittels Sägemesser die beiden Akkupackhaelften aufsaegen.
Plus- und Minusschiene mit Seitenschneider an den Akkus trennen.
Akkus entnehmen.
Loetfahne an der Diode - Kathodenseite trennen.
Grundplatte mit Diode abnehmen.
Minusloetfahne der Grundplatte bei 2 abtrennen.
Temperaturschalter und Isolierplatten entfernen.
Neue Akkus entsprechend zusammenloeten.
Isolierplatten einlegen nicht vergessen.
Akkus ins Pack einlegen, Anschluesse vorsichtig anloeten.
Gehaeuse mit Plastikkleber zusammenloeten.
Vorher unbedingt an den Kontakten U Messen, -falls doch eine Kontaktierung misslungen ist.

Akkus: Habe kaum Anbieter finden koennen.
Typ: P40/700LF Hoehe 28mm Durchmesser 16mm passt (Fa. Kusch)
5 Stueck.
Auf den Akkus steht: 70AFK als Typ, sie besitzen 700mAh, also besser als die Originalen.

Aufbau des Akkupacks:

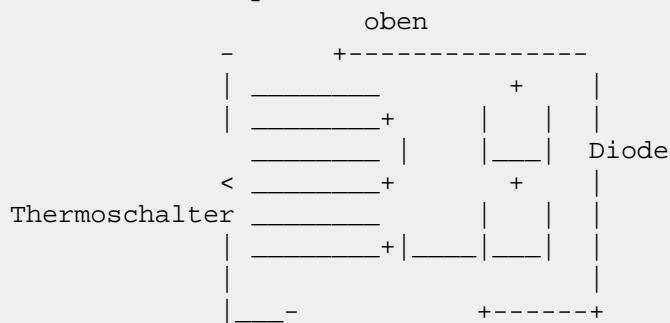

8. Technische Informationen

8.1 Ausgangsleistung in den Amateurfunkbändern in Abhängigkeit der Versorgungsspannung

12V DC (Netzteil):

VHF bis 5,0 W

UHF bis 3,5 W

6V DC (600mAh Akkupack PB-32)

VHF bis 2,5 W

UHF bis 2,0 W

8.2 TOT-Funktion

Der TH79 schaltet nach 10 Minuten DauerTX aus Sicherheitsgründen (Überhitzung) ab. Diese Sicherheitsfunktion ist Microprozessor gesteuert und kann nicht deaktiviert werden.
Mit der älteren Generation (siehe 1.0) ist es möglich ein DauerTXbetrieb per Tastenkombination für 10 Minuten zu aktivieren. VFO- oder MR-Taste drücken bis ein Pieps zu hören ist und danach zusätzlich PTT drücken. Loslassen.

Wer Infos aus dem Servicemanual für den TH79 braucht soll sich bei mir melden ! Ich verleihe es auch gerne mal.

Tips und Tricks pse to DG8NGN @DB0ABH.#BAY.DEU.EU or JANN @GMX.DE

Special Thanks to SQ1BSE Pawel, DD1JD Dirk, DL1RNO Juri, PA3GQJ Erik
DC2FR Wolfgang and DF9ZR Peter

73 und 55 vom Jann aus Nürnberg



This modification is read 1577 times.

[top of page](#)

20-02-1999

(TH-D7A) Kenwood TH-D7a TX band modification

Allows TX 136 - 173.995 and 400 - 479.995

Although I have performed this modification on my own radio with no problems noted, I take no responsibility in the accuracy of the procedure shown below. If you do not feel comfortable working with small surface mount components, you should not be performing this procedure.

1. Using Kenwoods program, download all saved settings from your radio. (All settings will be erased on power up after this mod)
2. Remove battery, antenna and freq/volume control knobs.
3. Loosen both fasteners from the antenna base and the freq/volume control shaft.
4. Remove the four screws that secure the back of the radio.
5. Pull the top plastic piece with the Led's off the top of the radio.
6. Gently pull on the rubber gasket that goes around the top of the radio.
7. Pull the bottom of the radio appart gently. Note: There will still be a ribbon cable connecting both parts (see picture). I removed the ribbon cable to make it easier to work on.

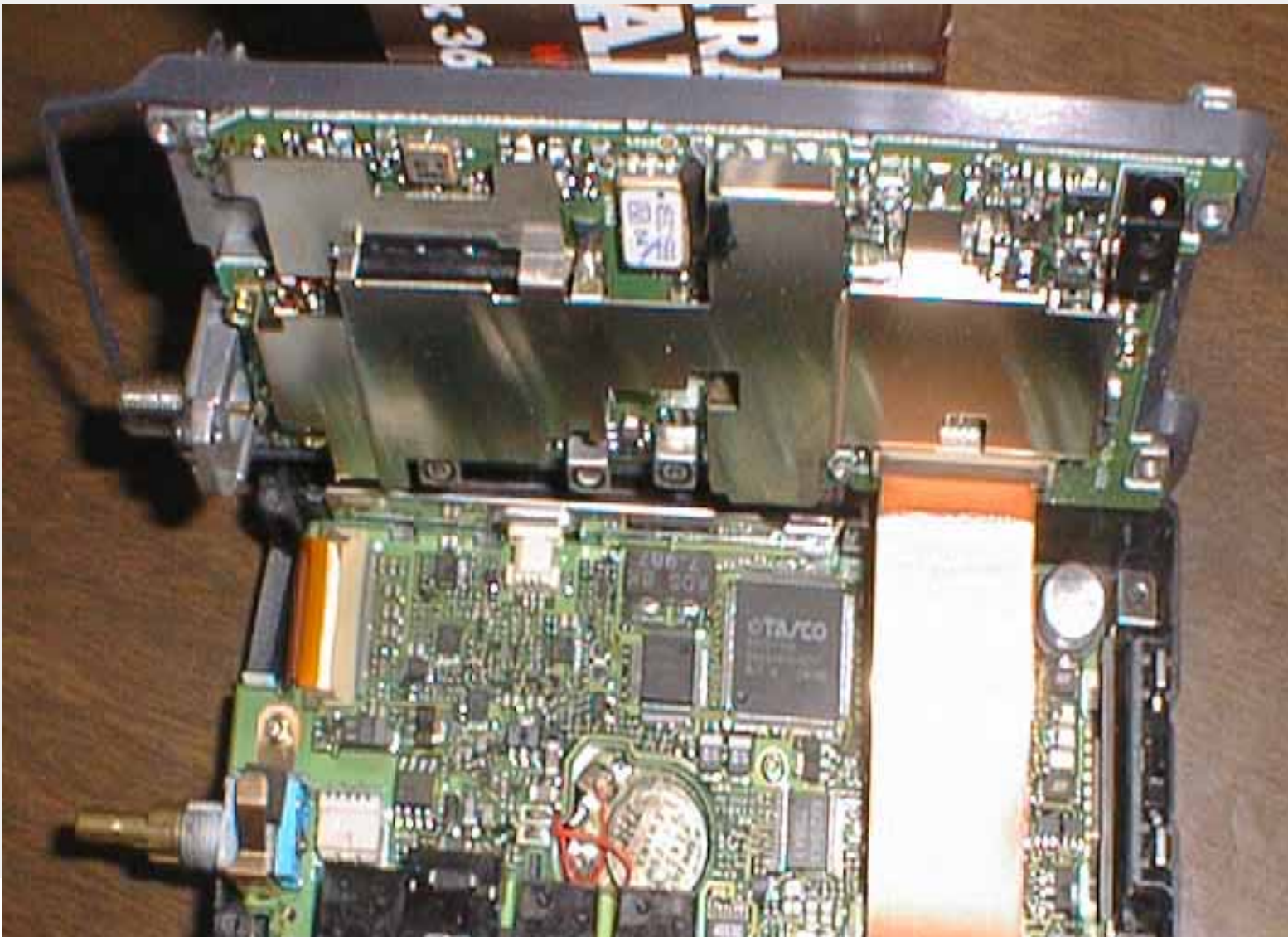



8. Pull the brown part of the ribbon cable connector upwards using your fingernail or small screwdriver. This will release the ribbon cable.

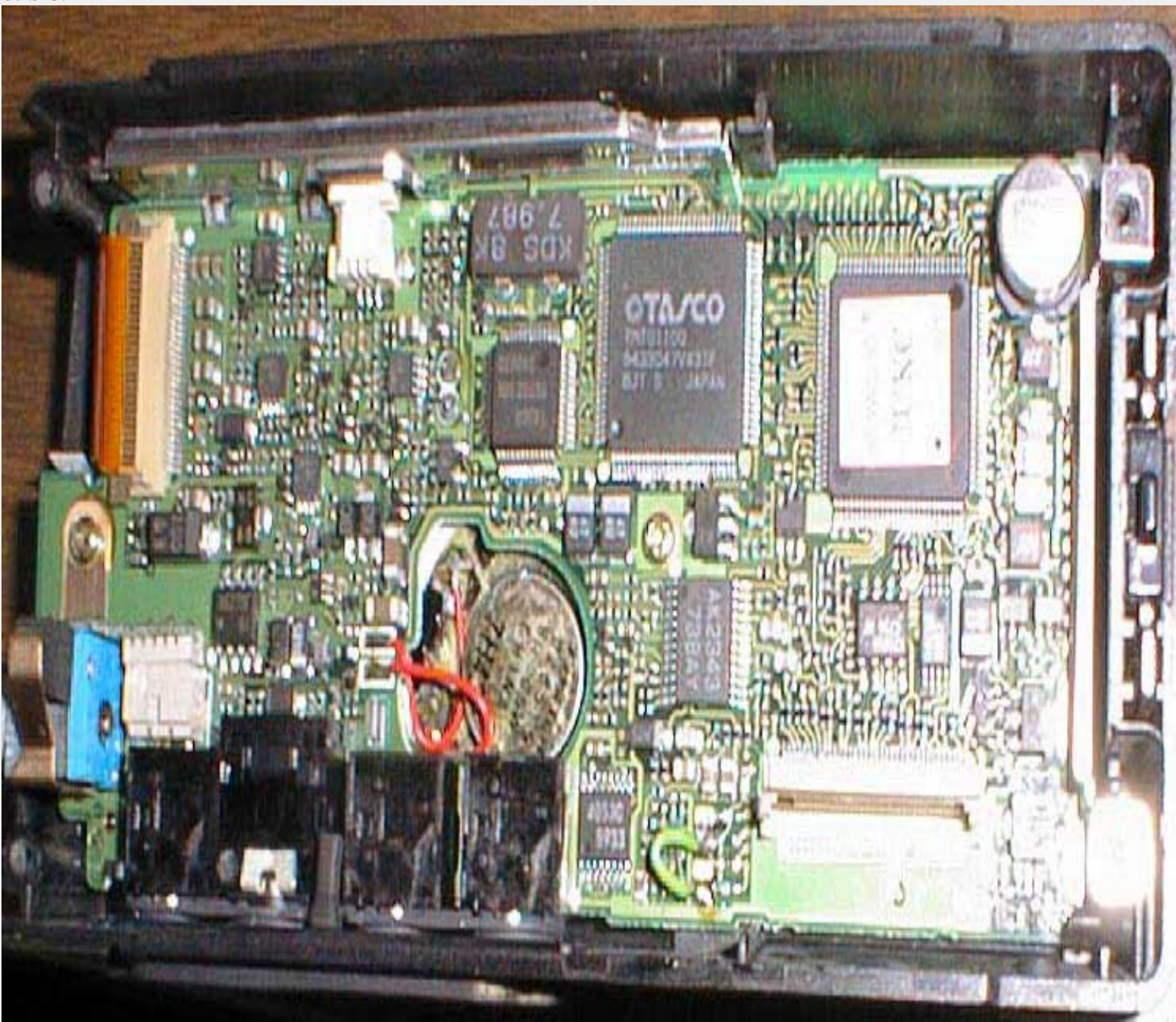

9. Locate the green wire. Under the green wire there are four small diodes in a neat row (they should have a miniature A on them if your eyesight is good). Using a soldering iron, remove the middle two diodes.



10. Put the radio back together in the reverse order it was taken apart.

Modification Notes:

It has been suggested that modifications to the TH-D7a may somehow void the manufacturers free firmware update that is said to be in the works. While I don't believe my modified transmitter will have any problems in getting its deserved firmware update, I did however save both diodes for future replacement if it ever becomes necessary. This may be a good idea if you were ever to want to "trade in" your radio to a store, or if warranty work is needed. (Just in case)

KD6VYV

Comments, additions? Email wdunckel@best.com. MODIFICATION.NET

23-04-2000

(TH-D7A) TH-D7A Firmware upgrade

Author: Kenwood Communication, inc.

Service Bulletin no. 1063 (24 February 1999)

UPGRADE INFORMATION:

The firmware in the TH-D7A can be upgraded to allow the following features and functions:

In GPS mode, recognize latitude and longitude to the "ten-thousandths" of a decimal place (4-digit precision). Currently it reads to the "hundredth" position.

In GPS mode, recognize negative temperatures such as - 20 degrees Fahrenheit.

Allow a comma to be used in the middle of a Command Sentence. The original firmware recognizes a comma as the end of a sentence.

UPGRADE PROCEDURE:

Send your TH-D7A to Kenwood Svc Ctr West for firmware upgrade. There is no need to call for an appointment or return authorization.

Kenwood Svc Ctr West
13030 Alondra Blvd. #104
Cerritos, CA. 90701-2257
(562) 483-8740
Mon. – Friday 9:00AM – 6:00PM PST

At this time, only KSC-West can upgrade the firmware in the TH-D7A since special equipment is required to perform the work.

NOTE:

This upgrade applies to units with serial number 010xxxxx and below. New firmware was used in production from 011xxxxx. So that there is no confusion, the following serial numbers have not yet been produced. When they are produced, they will have the new firmware installed.

012xxxxx, 100xxxxx, 101xxxxx, 102xxxxx,

This bulletin only applies to TH-D7A transceivers sold in the USA. This information may not be valid for other TH-D7 equipment sold in Europe or other markets.

This upgrade is covered under the 1-year warranty period to the original owner.

This modification is read 1868 times.

[top of page](#)

27-10-2001

(TH-D7A) TH-D7A/E Conversion Document

Converting the TH-D7A/E makes possible the following function expansion.

- Reception band expansion
118 MHz (air) band (K type supported)
- Frequency band expansion
144 MHz band (Excepting sub 144MHz band)
430 (440) MHz band
- Channel display mode
- 118 MHz FM/AM switching (K type supported)

1. Destination and microcomputer

There are types of microcomputers: the E type and the K destination type.

2. Destination diode

The destination is distinguished by the combination of four diodes for the control unit (X57-570X-XX)(B/4).

Destination diode Ref. No.	D508	D507	D503	D502/Jumper
Destination diode No.	3	2	1	0

3. Destination list

The destination tables for the diode combination are Tables 1, 2.

4. Conversion method

Reception band and frequency band expansion

- Eliminating one destination diode (D502) (actually, cutting short jumper W500) makes possible 118MHz band reception. (K type supported) Also, the 144MHz and 430MHz (440MHz) band frequencies are extended.
- For the conversion, W500 (short jumper) on the solder side of the B/4 control unit board is cut. Also, the destination can be changed as in Table 1 and 2 by the presence/absence of destination diodes D503, D507, and D508.

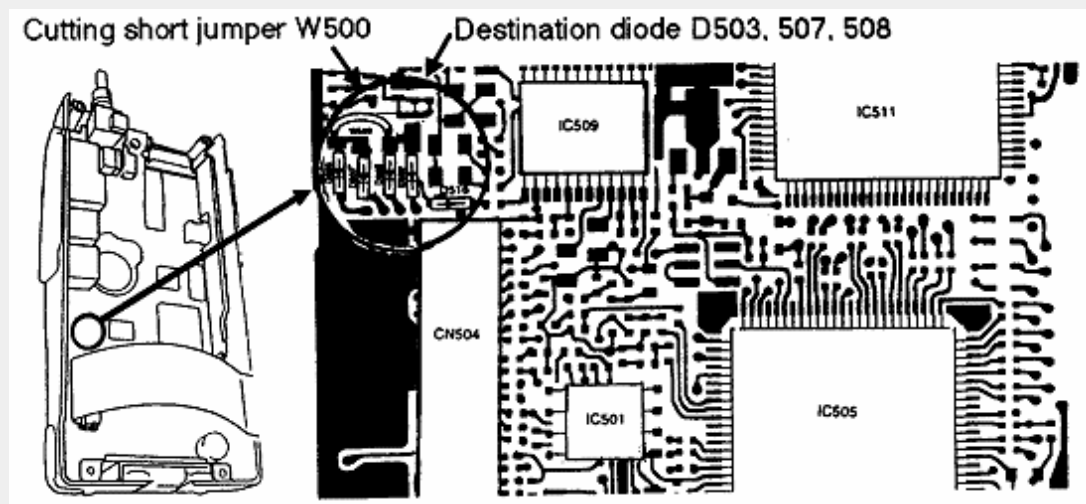

- After reception expansion, the band can be switched as follows with the [F] -> [A/B] key.
A Band (Upper Display)
144MHz <-> 118MHz

B Band (Lower Display)
430(440)MHz <-> sub 144MHz

Reference data for reception sensitivity and transmission output after the conversion are in Table 3 through Table 5.

Adjustment method

The receive expansion band (118Mhz) was set at the factory prior to delivery. When realignment is required, place this unit in SET mode and use the following procedure.

Set mode usage

The SET mode is used to adjust this unit. SET mode allows setting the level of the following items.

1. Squelch threshold on each band
2. S meter each band: 1st segment/All segment: ON
3. Hi/Lo/EL transmit output on each band
4. Overvoltage warning threshold (13.8V)

The level entered in SET mode is written on the EEPROM. This means the written data is kept intact even if power is cut off or the unit is reset.

When replacing the EEPROM all items must be rewritten (reset).

Setting Procedure

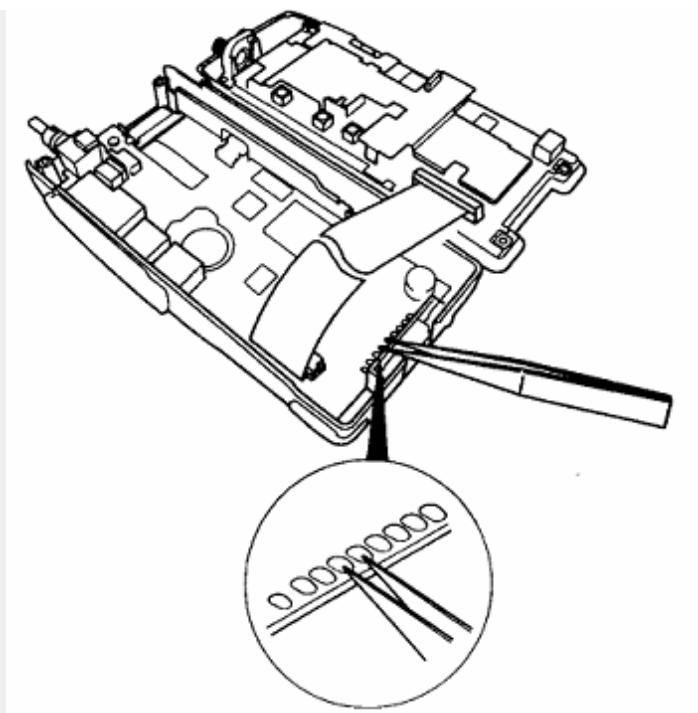

Open the unit as shown, turn the power on (POWER ON) and momentarily short the SET point on the component (soldered) side of the TX-RX unit (B/4) with tweezers or similar tool. (See the figure below.)

A beep tone sounds and a [--] mark appears on the display. This shows the unit is now in "SET mode".





Operation

1. Set the squelch threshold

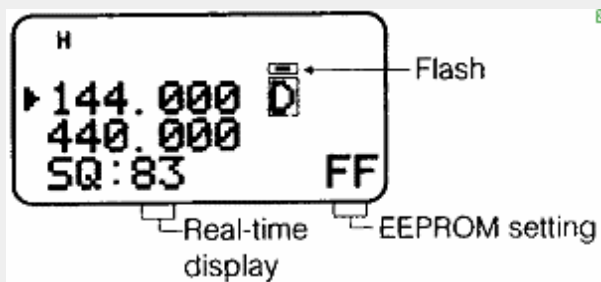
- Use the  key to align the bottom of the display with 'SQ' of the squelch adjust screen. Use the **[BAND]** key and select the band and frequency with the encoder.
- inputte SSG into the antenna termnal.
- Pressing the  key sets the squelch threshold.
- Set all the receive bands in the same way.



2. Set the S meter

- Use the  key to align the bottom of the display with 'SM' of the S meter adjust screen. Use the **[BAND]** key and select the band and frequency with the encoder.
- Input the specified signal from the SSG into the antenna terminal.
- Press the  key to turn on the 1st segment or press the  key to turn on all segments.
- Set all the receive bands in the same way.

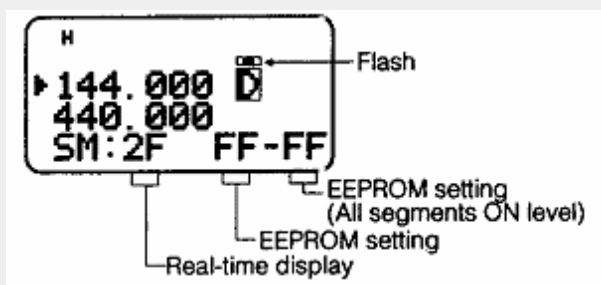

Entry Values

Input the SSG level for each band setting from the ANT terminal and press the correct key.

Press key (cursor key)	SQ level	S1 level (1st segment on)	S9 level (All segments on)
Band (SSG frequency)			
118Mhz (120.050)	-121.0dBm	-120.0dBm	-75.0dBm

Note : SSG is standard modulation. (AM : 1KHz/60%)

Other Items

- Each setting you make is overwritten on the previous data so you can enter settings in any order or make individual settings.
 - The real-time display is updated every 200ms.
 - Items which have not been set are shown with an "FF" on the display.
 - Turn off the power (POWER OFF) in order to cancel "SET mode".
 - Reset the VFO after finished with the previous steps.
- After making the Receive Expand Modification perform 118 Mhz band FM/AM switching in 'SET mode'.
 - Select the 118Mhz band and press the **[MENU]** key to alternately switch between AM and FM.

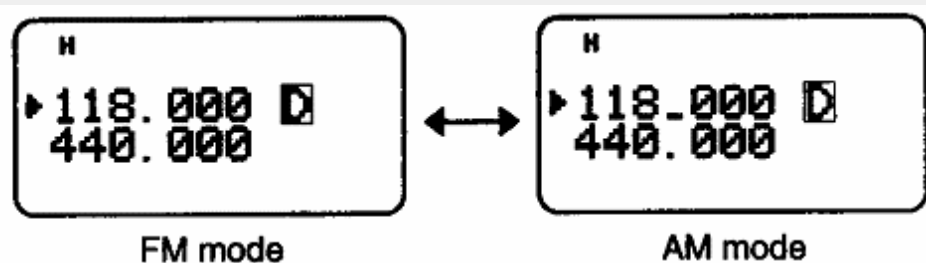

(When in AM, the MHz dot becomes an elongated horizontal bar.
After canceling SET mode, refer to the "Instruction Manual" for selecting AM/FM.)

Channel Display Mode

Channel display mode is for showing only the memory channel numbers without displaying the frequency.

Use either of the following 2 methods to enter channel display mode.

Method 1 : Turn power on while holding down the **[A/B]** keys. (Check the instruction manual since this is referred to there.)

Method 2 : Remove a component from the printed circuit board.

Set channel display mode by removing the channel display dip diode (D516). When channel display is set with this method you cannot return to the frequency display. (The channel display dip diode (D516) must once again be installed on the board in order to used the frequency display.)

- The mode sets to channel mode. VFO mode and CALL mode can no longer be set.

Operating Method

Before attempting the modification, write the data you need into the memory channel. (Write in at least one channel.)

- Write the desired data into the memory channel.

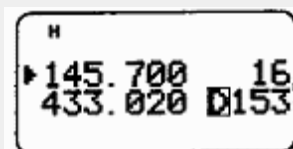

- The channel display mode switches alternately switches on or off each time power is turned on while the **[A/B]** keys are held down. A memory name appears for channels in which a memory name is registered. However a CH is displayed for channels in which nothing was registered.

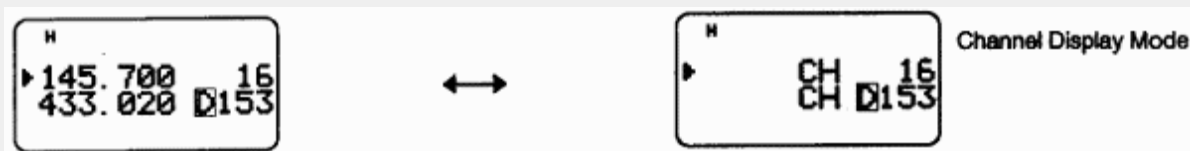

Doing the Modification

Channel Display Mode

Use a solder iron and remove the dip diode (D516) on the soldered side of the control unit (B/4) circuit board (back side of display).

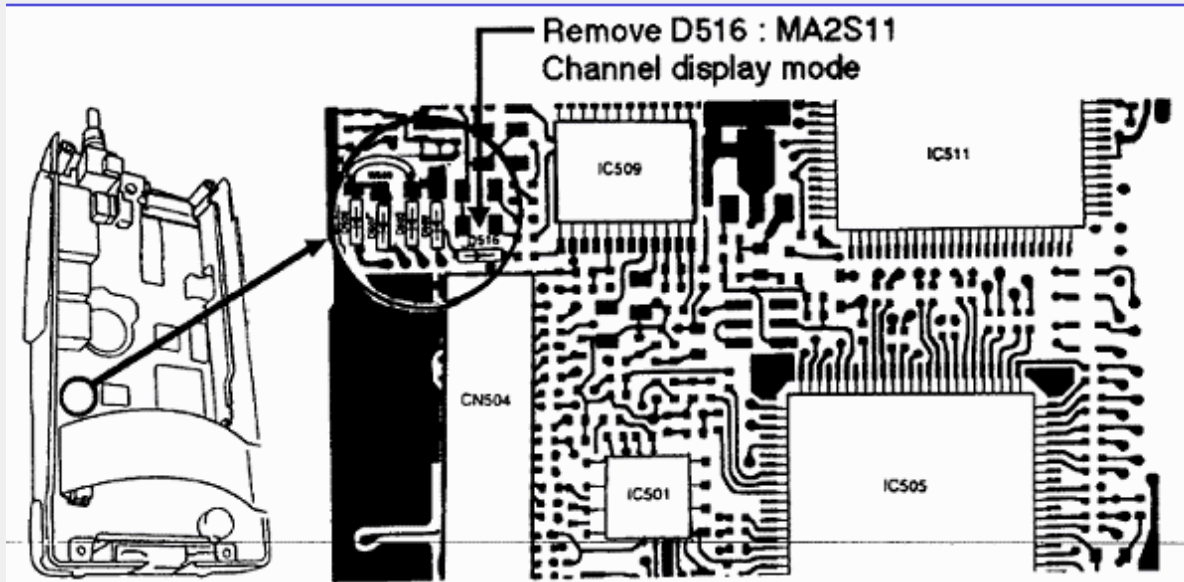

Caution

- You cannot set channel display mode unless at least one memory channel has been registered.

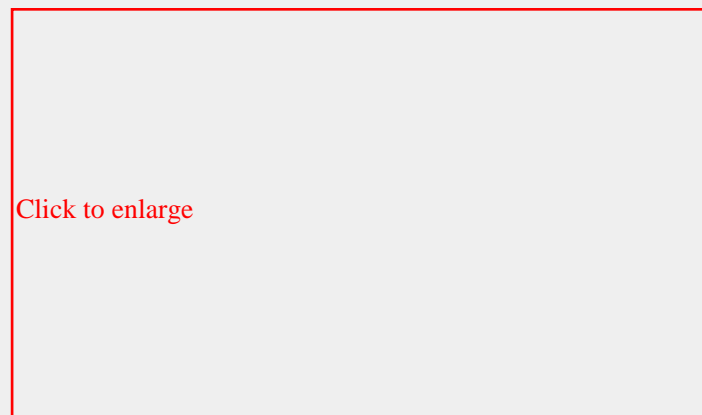
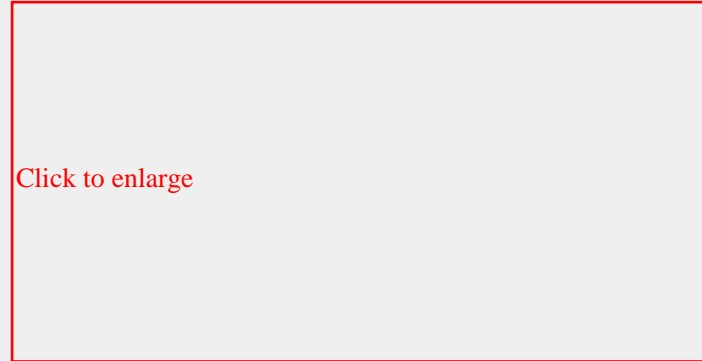

Click to enlarge

Click to enlarge

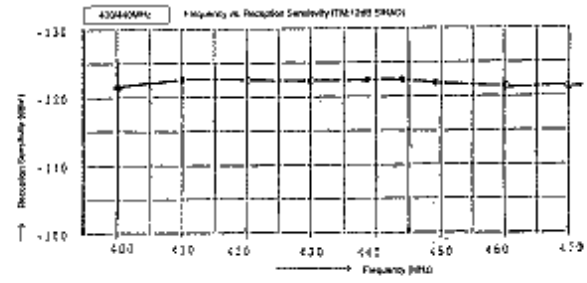
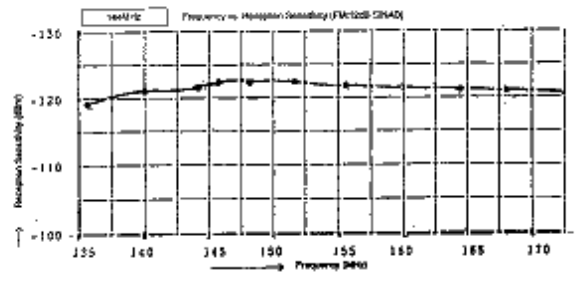
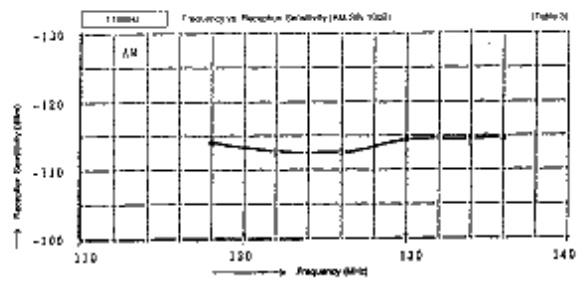

6

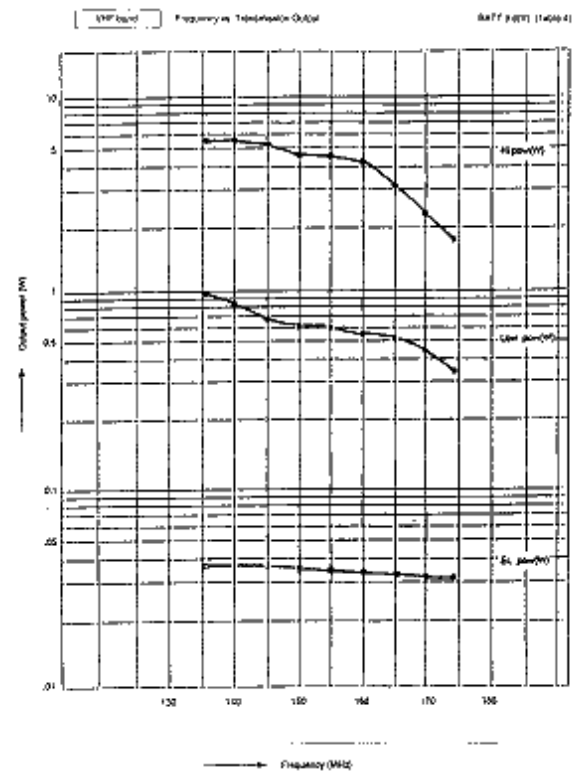

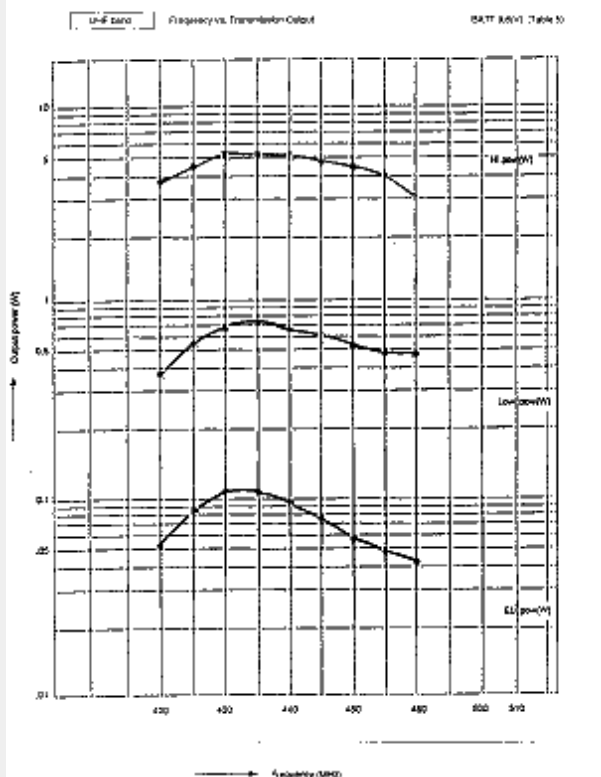

This modification is read 1414 times.

[top of page](#)

28-10-2001

(TH-D7a) Memory Control Program for TH-D7 V. 0.01 Beta

Author: Kenwood

[Download](#) Memory Control Program for TH-D7 V. 0.01 Beta

This modification is read 1300 times.

[top of page](#)

03-01-1999

(TH-D7E) TH-D7E extended RX

From: PA0HWP@PI8HWP.#NBW.NLD.EU

As a former owner of a TH79E and now playing with the TH-D7E, i wondered if RX-EXTENSION was as simple as just cutting one wire...

The answer is YES..... just follow these steps :

- Remove the battery-pack
- Remove the 4 screws on the backside-edges
- Remove the 2 knobs on top of the TH-D7E (volume and scrolling)
- Remove the nuts of the antenna-connector and the rotary switch
- Remove the TOP-cover
- Carefully remove the metal-embedded-printed circuitboard (don't break the rubber sealingstrip!)
- Look for a little GREEN wire near the speaker-connection on the PC-board
- Just CUT the GREEN WIRE
- Reassemble the TH-D7E in the reverse way

Now you have extended RX : Band A 136 - 174 Mhz
 SUBband A 118 - 136 Mhz - AM or FM
 Band B 400 - 480 Mhz

I didn't look for further command-expansion or additional options, so keep me posted for changes, related to the RX-expansion.

Enjoy your wide-range reception with the TH-D7E

Best 73, Hans Pa0hwb @ PI8HWP

Date: 15-08-2001

User comment

From: [Peter Koch](#)

Subject: How to open

Thanks to [Peter Koch](#) for the good pictures.

Click on any photo to enlarge the photo.



This modification is read 3254 times.

[top of page](#)

10-03-2001

(TH-D7E) Changes a TH-D7E into a TH-D7A and enables the SKY-COMMAND option

Author: PA3DFH, Robert - pa3dfh@hta-systems.com. MODIFICATION.NET

Although I have performed this modification on my own radio with no problems noted, I take no responsibility in the accuracy of the procedure shown below. If you do not feel comfortable working with small surface mount components, you should not be performing this procedure.

Using Kenwoods program, download all saved settings from your radio. (All settings will be erased on power up after this mod).

*******WARNING*******

Don't restore the memory channels as they force the radio to go into 'channel' mode because there seems to be an incompatibility between a TH-D7E and a TH-D7A PC file. The only way to get rid of this channel mode is restoring the data again to the radio. It's probably easier and saver to make the radio setting manually after this modification.

Remove battery, antenna and freq/volume control knobs.

Loosen both fasteners from the antenna base and the freq/volume control shaft.

Remove the four screws that secure the back of the radio.

Pull the top plastic piece with the Led's off the top of the radio.

Gently pull on the rubber gasket that goes around the top of the radio.

Pull the bottom of the radio appart gently. Note: There will still be a ribbon cable connecting both parts.

Locate the green wire. Under the green wire there are three small diodes in a neat row and place for number four (they should have a miniature A on them if your eyesight is good). mount diode number 4 (a drop of solder probably also does it but I did not check it).

Put the radio back together in the reverse order it was taken appart.

After this the radio has changed into an A version which means that:

- 1750 Hz tone does not work anymore
- the center frequencies have changed
- the default shift on 70 cm has changed to 5MHz
- But the big fun: SKY COMMAND (menu 4) has been enabled. This is a very nice feature in combination with a TS2000 (see the TS2000 section on how to modify that radio for sky command).

PA3DFH (Robert, pa3dfh@hta-systems.com.MODIFICATION.NET)

Date: 14-02-2002

User comment

From: [Aris SV2GQN](#)

Subject: broblem mod th-d7e

73"

my name is Aris, i have a mod broblem with enable skycomand to th-d7e
i did this mod and stop work the up/down left/right cersor also the righth side of butons
any help adout this?
note:the th-d7 is the 1'version

This modification is read 2936 times.

[top of page](#)

27-10-2001

(TH-D7E) TH-D7A/E Conversion Document

Converting the TH-D7A/E makes possible the following function expansion.

- Reception band expansion
118 MHz (air) band (K type supported)
- Frequency band expansion
144 MHz band (Excepting sub 144MHz band)
430 (440) MHz band
- Channel display mode
- 118 MHz FM/AM switching (K type supported)

1. Destination and microcomputer

There are types of microcomputers: the E type and the K destination type.

2. Destination diode

The destination is distinguished by the combination of four diodes for the control unit (X57-570X-XX) (B/4).

Destination diode Ref. No.	D508	D507	D503	D502/Jumper
Destination diode No.	3	2	1	0

3. Destination list

The destination tables for the diode combination are Tables 1, 2.

4. Conversion method

Reception band and frequency band expansion

- Eliminating one destination diode (D502) (actually, cutting short jumper W500) makes possible 118MHz band reception. (K type supported) Also, the 144MHz and 430MHz (440MHz) band frequencies are extended.
- For the conversion, W500 (short jumper) on the solder side of the B/4 control unit board is cut. Also, the destination can be changed as in Table 1 and 2 by the presence/absence of destination diodes D503, D507, and D508.

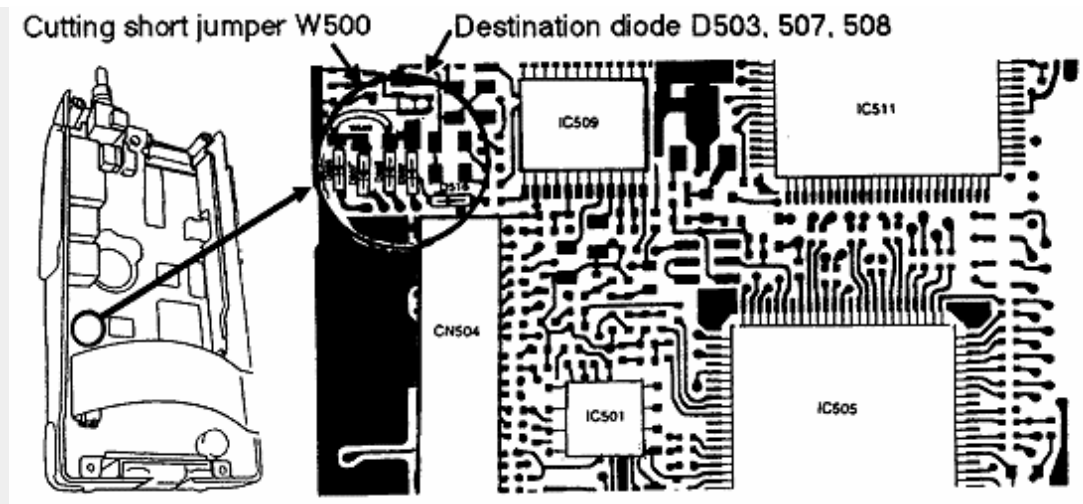

- After reception expansion, the band can be switched as follows with the **[F]** -> **[A/B]** key.
 - A Band (Upper Display)
144MHz <-> 118MHz
 - B Band (Lower Display)
430(440)MHz <-> sub 144MHz

Reference data for reception sensitivity and transmission output after the conversion are in Table 3 through Table 5.

Adjustment method

The receive expansion band (118Mhz) was set at the factory prior to delivery. When realignment is required, place this unit in SET mode and use the following procedure.

Set mode usage

The SET mode is used to adjust this unit. SET mode allows setting the level of the following items.

1. Squelch threshold on each band
2. S meter each band: 1st segment/All segment: ON
3. Hi/Lo/EL transmit output on each band
4. Overvoltage warning threshold (13.8V)

The level entered in SET mode is written on the EEPROM. This means the written data is kept intact even if power is cut off or the unit is reset.

When replacing the EEPROM all items must be rewritten (reset).

Setting Procedure

Open the unit as shown, turn the power on (POWER ON) and momentarily short the SET point on the component (soldered) side of the TX-RX unit (B/4) with tweezers or similar tool. (See the figure below.)

A beep tone sounds and a **[--]** mark appears on the display. This shows the unit is now in "SET mode".

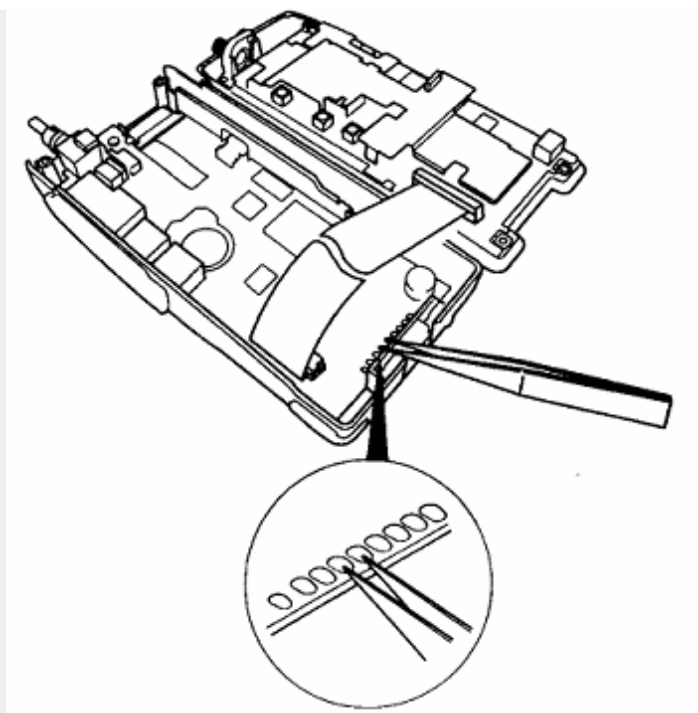

Operation

1. Set the squelch threshold

- Use the key to align the bottom of the display with 'SQ' of the squelch adjust screen. Use the **[BAND]** key and select the band and frequency with the encoder.
- inputte SSG into the antenna termnal.
- Pressing the key sets the squelch threshold.
- Set all the receive bands in the same way.

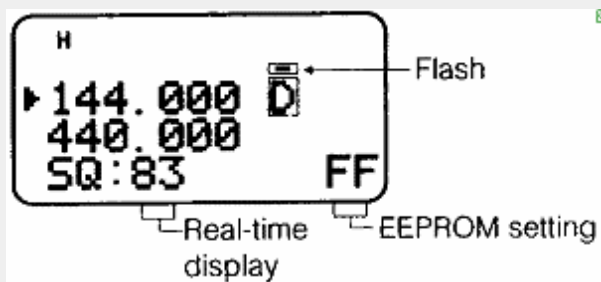

2. Set the S meter

- Use the key to align the bottom of the display with 'SM' of the S meter adjust screen. Use the **[BAND]** key and select the band and frequency with the encoder.
- Input the specified signal from the SSG into the antenna terminal.
- Press the key to turn on the 1st segment or press the key to turn on all segments.
- Set all the receive bands in the same way.

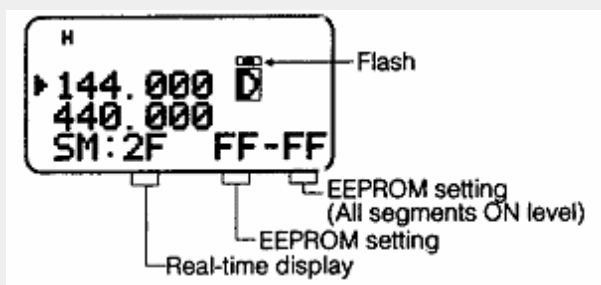

Entry Values

Input the SSG level for each band setting from the ANT terminal and press the correct key.

Press key (cursor key)	SQ level	S1 level (1st segment on)	S9 level (All segments on)
Band (SSG frequency)			
118Mhz (120.050)	-121.0dBm	-120.0dBm	-75.0dBm

Note : SSG is standard modulation. (AM : 1KHz/60%)

Other Items

- Each setting you make is overwritten on the previous data so you can enter settings in any order or make individual settings.
 - The real-time display is updated every 200ms.
 - Items which have not been set are shown with an "FF" on the display.
 - Turn off the power (POWER OFF) in order to cancel "SET mode".
 - Reset the VFO after finished with the previous steps.
- After making the Receive Expand Modification perform 118 Mhz band FM/AM switching in 'SET mode'.
 - Select the 118Mhz band and press the **[MENU]** key to alternately switch between AM and FM.

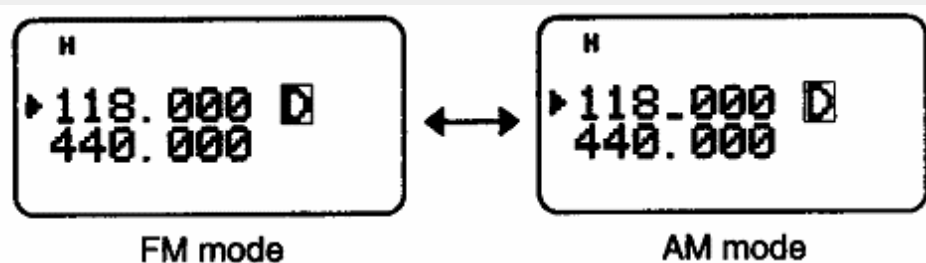

(When in AM, the MHz dot becomes an elongated horizontal bar.
After canceling SET mode, refer to the "Instruction Manual" for selecting AM/FM.)

Channel Display Mode

Channel display mode is for showing only the memory channel numbers without displaying the frequency.

Use either of the following 2 methods to enter channel display mode.

Method 1 : Turn power on while holding down the **[A/B]** keys. (Check the instruction manual since this is referred to there.)

Method 2 : Remove a component from the printed circuit board.

Set channel display mode by removing the channel display dip diode (D516). When channel display is set with this method you cannot return to the frequency display. (The channel display dip diode (D516) must once again be installed on the board in order to used the frequency display.)

- The mode sets to channel mode. VFO mode and CALL mode can no longer be set.

Operating Method

Before attempting the modification, write the data you need into the memory channel. (Write in at least one channel.)

- Write the desired data into the memory channel.

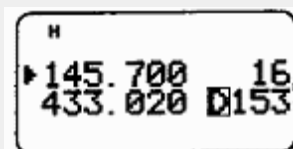

- The channel display mode switches alternately switches on or off each time power is turned on while the **[A/B]** keys are held down. A memory name appears for channels in which a memory name is registered. However a CH is displayed for channels in which nothing was registered.

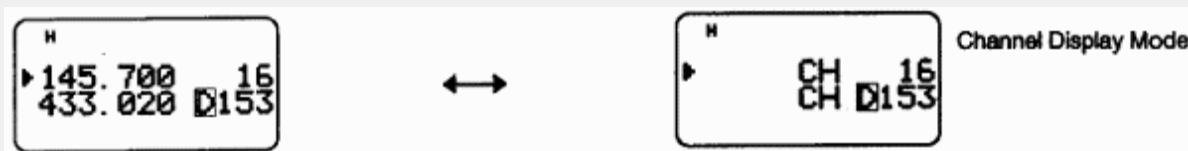

Doing the Modification

Channel Display Mode

Use a solder iron and remove the dip diode (D516) on the soldered side of the control unit (B/4) circuit board (back side of display).

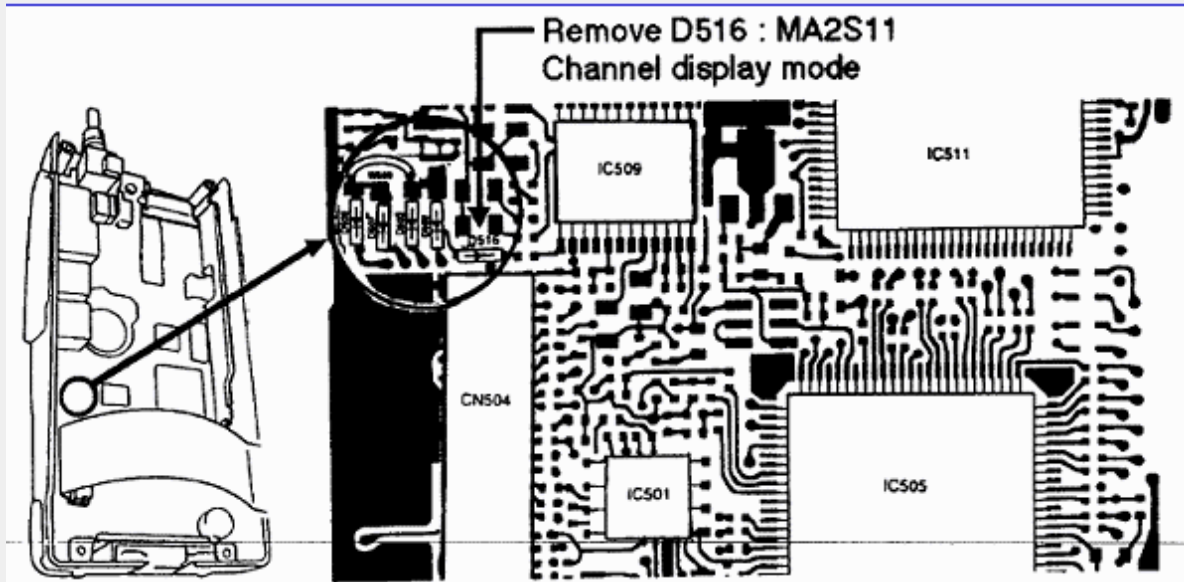

Caution

- You cannot set channel display mode unless at least one memory channel has been registered.

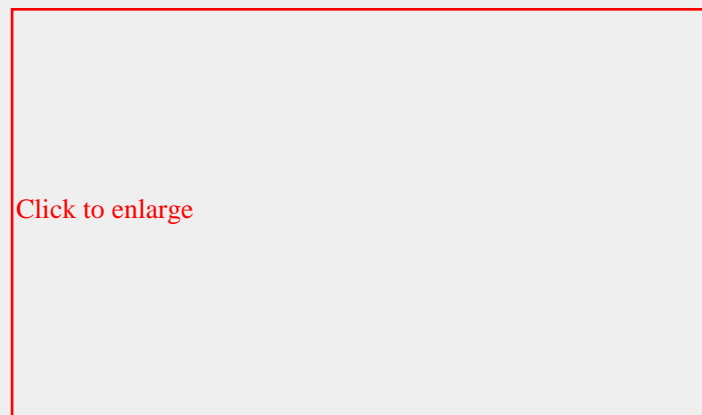

Click to enlarge

Click to enlarge

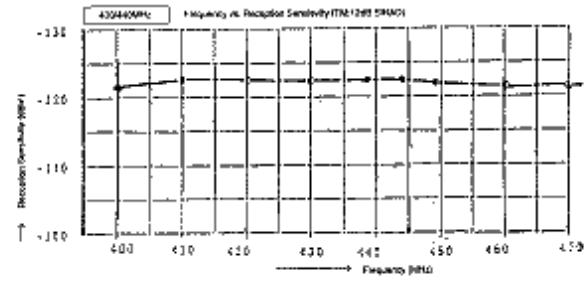
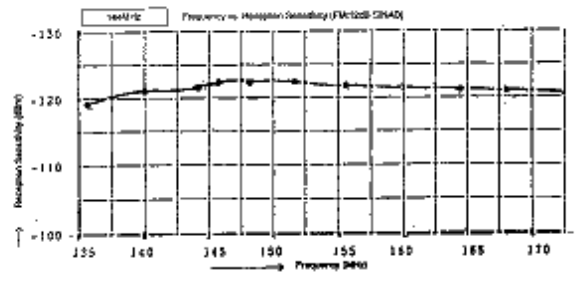
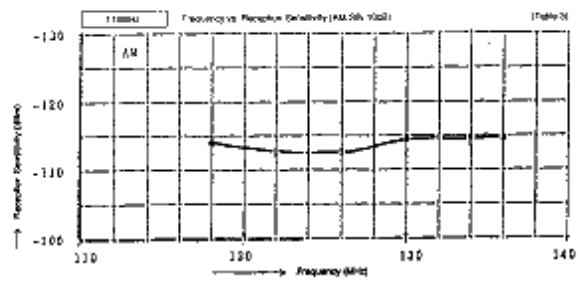

6

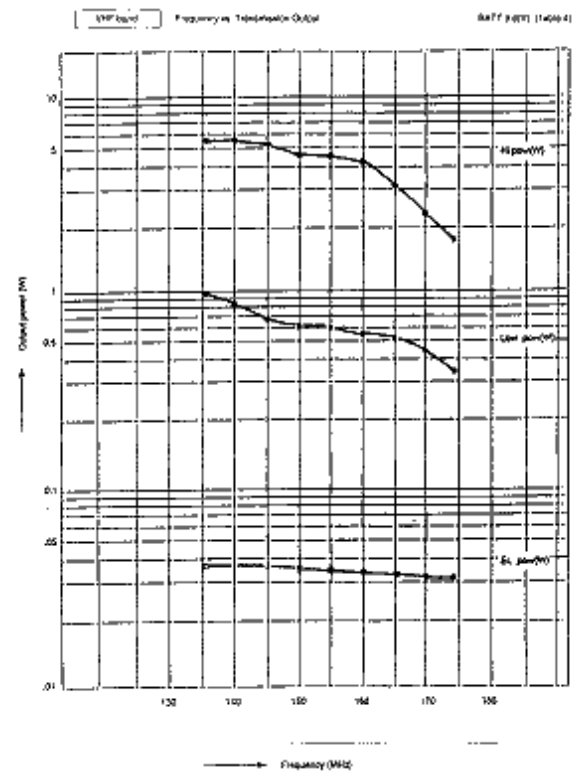

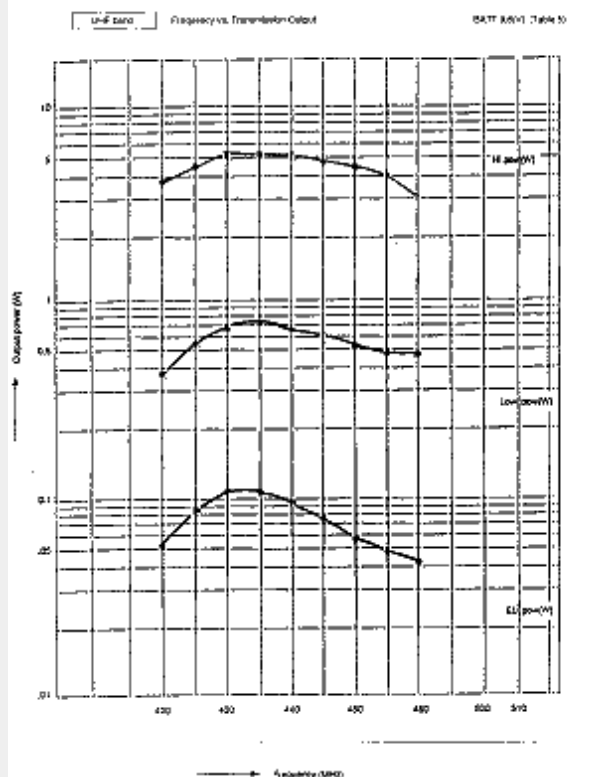

This modification is read 2254 times.

[top of page](#)

28-10-2001

(TH-D7E) Memory Control Program for TH-D7 v. 0.01 Beta

Author: Kenwood

[Download](#) Memory Control Program for TH-D7 V. 0.01 Beta

This modification is read 2014 times.

[top of page](#)

29-09-2001

(TH-F6) Extended transmit for TH-F6A/E

This mod expand the frequency range to:

TH-F6A can receive 142-152, 216-235, 420-450 MHz on A-band.

TH-F6A can transmit 137-174, 216-235, 410-470 MHz.

TH-F7E can receive 137-174, 410-470 MHz on A-band.

TH-F7E can transmit 137-174, 410-470 MHz.

First remove the grey plastic Mic speaker Cover on the side of the radio (trust me if you forget it will be impossible to get it apart!). Then the ant. and the vol tuning knob and the nuts below then, take the battery off and remove the two screws below the battery pack.

Take the cover off very slow cause you damage the speaker wire if you mess up and go fast!.. You can leave the speaker connected, just push the top part off to the side very gently!

Once in the radio look over to the left side below the Mic...

You will see a series of three diodes remove the top one (See photos)

Look below the last diode and you will see a chip resistor (See photos)

I heated them very quick and placed a thin jewelers screwdriver underneath and it came right off the board.

Just another note, make sure that the joystick mounts correct or else it might not function correct.

Caution:

These mods WILL reset and initialise the memory contents. So, write down important memory channel frequencies before performing the mod.

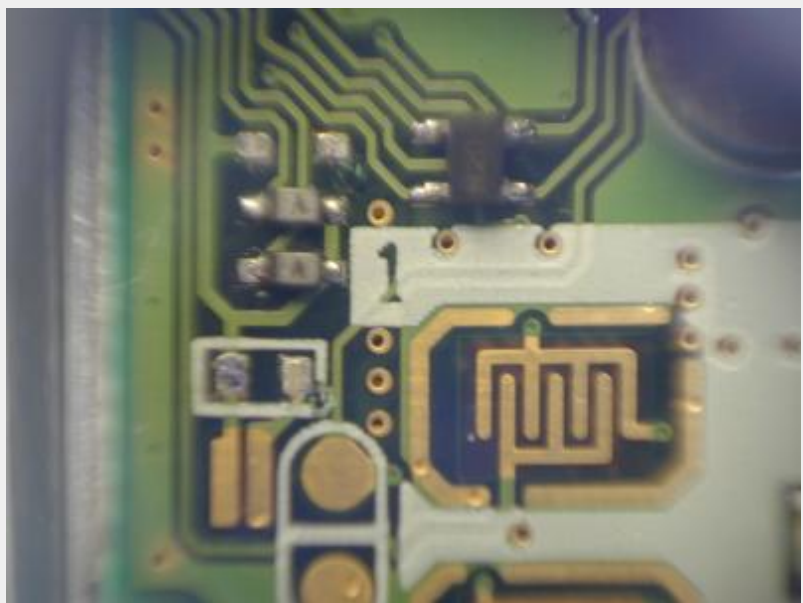
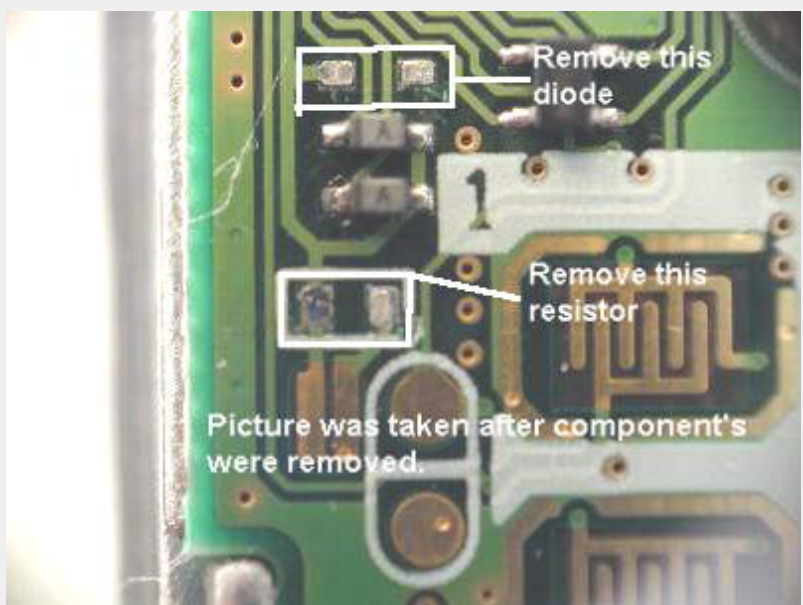
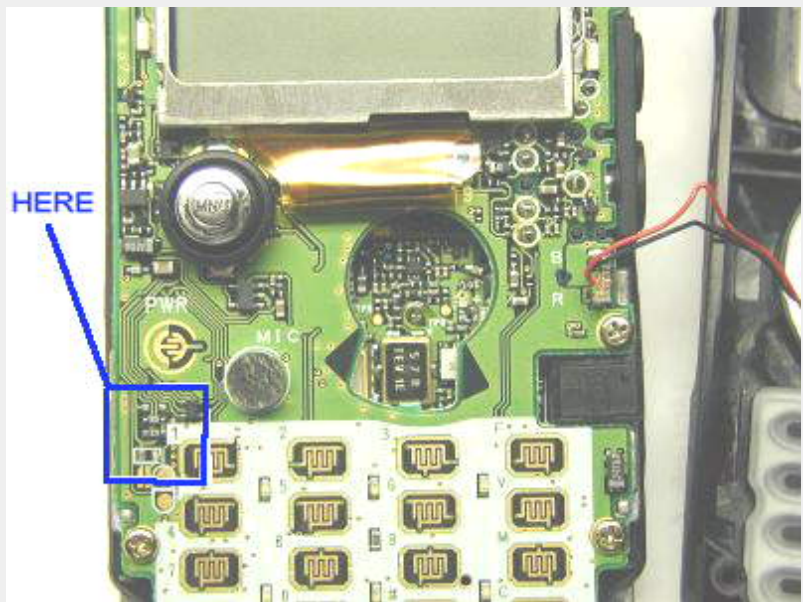

Author: azkoza@yahoo.com - KB7QPK.MODIFICATION.NET

*Note: The interface described here has been verified to work on the TH-G71 and also the the TH-F6A/TH-F7E.

- [Background](#)
- [Plug pinout](#)
- [Schematic](#)
- [Building a homemade interface](#)
- [Implementations built by other hams](#)
- [Using the interface / Software](#)
- [Debugging problems with the interface](#)
- [Programming the radio with a PC](#)



Background

I wanted to make my own cable to program my Kenwood TH-G71A ham radio with a PC, but the owner's manual simply did not show the pinout needed for the connector plugs. I searched the web but was not able to find this information but I did discover that several other radios used an RS-232-to-logic (0-3.3V) level-shifter and a Full-duplex serial connection (separate RXD / TXD), and found schematics for such interfaces for other radios. I also found a device called the "[MAK interface](#)" which claimed to work with the TH-G71A, and the web site listed an interface cable.

With these clues, and after studing the signals coming out of the radio (and lots of debug time ...), I finally figured out the plug connections at the radio end.

I was able to use basically the same interface schematic that was claimed to work for the Kenwood PG-4S cable (which is used for the TM-G707 / TM-V7 radios instead of the Kenwood TH-G71).

Refer to <http://www.fiberpipe.net/~tateb/pg4s.html> for the schematic for the PG-4S interface:

The DB-9 connector to the PC is the same, but the connector on radio side is different. (Instead of the 6-pin mini-DIN connector, use the 2.5mm and 3.5mm phono plugs for the TH-G71)

Refer to Drawing at the URL above (Tate Belden's site), right hand side, starting at the top:

1. Ignore the tie between pins 4 and 5 of the mini-DIN connector. (There is no such tie on the TH-G71 Cable)
2. The interface's "TXD" goes to Ring of 2.5mm plug. (cathode of the diode on the interface)
3. The interface's "RxD" goes to the Shield of 3.5mm plug. (collector of NPN on interface) (Or just use a mono 1/8" jack and connect this to the shield!)
4. GND goes to shield of the 2.5mm plug.
5. The tips of both plugs are No-connect.

Schematic tweaks:

Note: If you have an interface that already works on another radio such as the Kenwood TM-G707 / TM-V7, then you may not need to make these changes!

1. Change R1 from 150ohm to 1K ohm (this is the resistor feeding the zener diode). I found that 150ohms loaded the line too much and the resulting voltage was too low to power the interface from the Serial port. If you have problems, be sure that the cathode of the Zener is at about 4.9V. I found that the interface worked down to about 3.2V when I just powered this from a variable power supply instead of through the PC serial port (after removing R1 and the zener and just applying voltage at C1)
2. add a 150K ohm resistor between the Radio TXD to gnd. I did this just to keep the voltage down on the TxD pin because the radio seems to be 3.3V I/O pin (not 5V)

TH-G71 PC cable interface plugs.



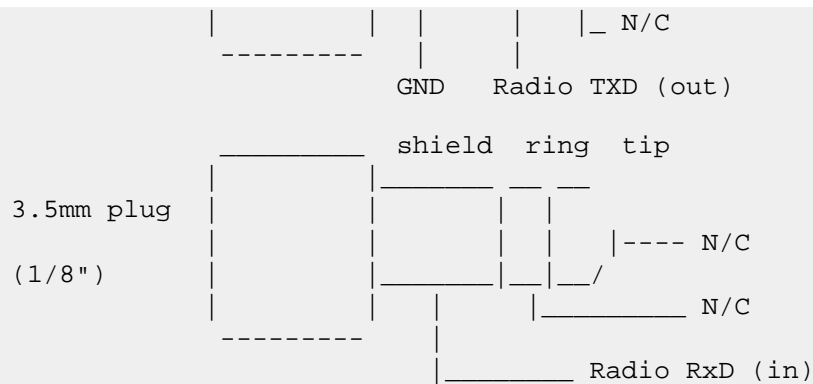

Update: Dec 2001: The Kenwood manual for the newer TH-F6 radio shows the pinout for the Plugs (page 46). Through Dec 17, 2001, this web page showed the Ring and Shield of the 3.5mm plug both shorted together, but I have updated the plug pinout to match the Kenwood documentation, and I confirmed that it does work as shown, without the connection to the ring.

I was able to find a 90-degree "elbow" shaped, 2.5mm stereo plug at Radio Shack (p/n 274-298).

Here is the resulting schematic:

PC programming cable for TH-G71A radio.
Jan 28, 2001. g71cbl2.cir
Verified working.

Parts:
1N4733: 5.1V Zener Diode
C1, C2: 1uF, 16V electrolytic
D1, D2: 1N4148
Q1: PNP Switching (2N3906)
Q2: NPN Switching (2N3904)

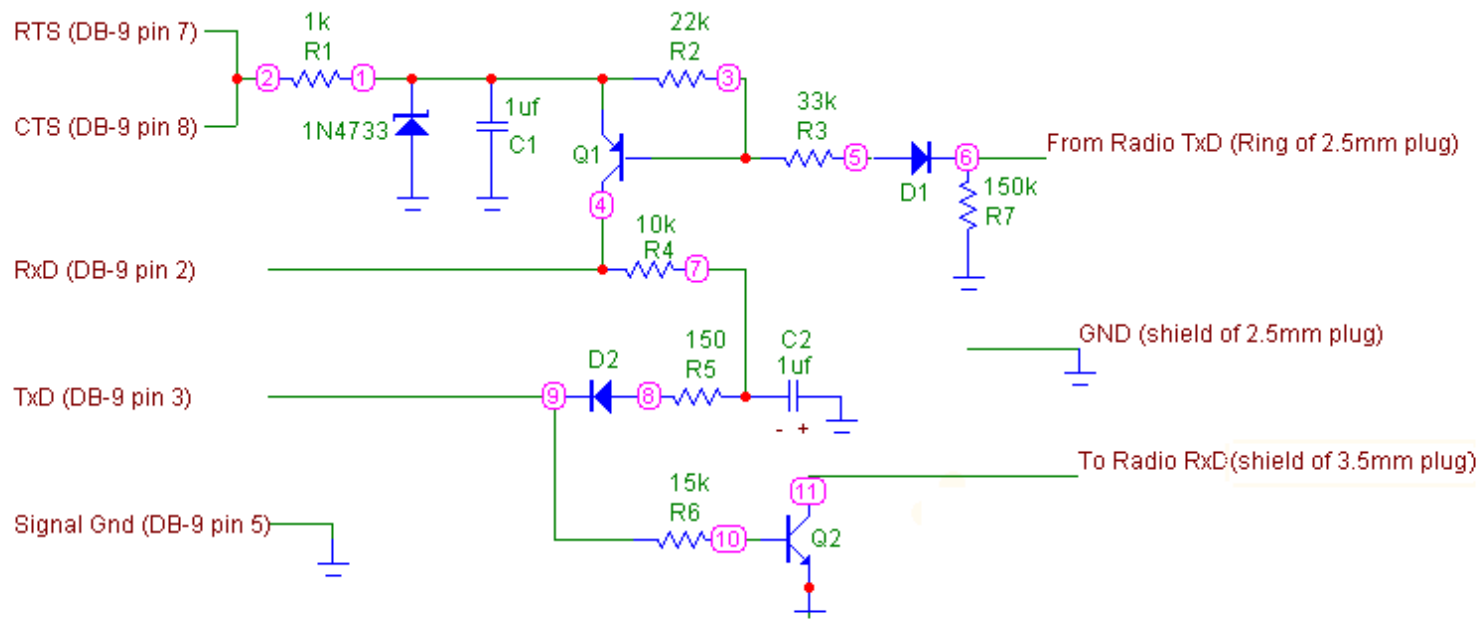

Notes:
1. This is a level-shifter converting RS-232 <=> Logic (0-3.5V) levels.
2. Tip of 2.5mm plug and tip of 3.5mm plug (to radio) are No-connect
3. Kenwood G71 has internal pullups to 3.5V on RXD and PTT signals.

Disclaimer: Although this works fine for me, use at your own risk.

Building it - my homemade interface

I built the interface on a Small PC board originally purchased from [Circuit Specialists](#), Mesa, AZ.

It is "Datak" brand prototyping board part number 12-607.

([RadioShack.com](#) carried them as p/n 910-3811 (in their catalog) but I don't see them on-line anymore.)

A recent [Google Search](#) on *datak 12-607* found the following as possible sources:

- [Ocean State Electronics](#) (Westerly, RI. (800)866-6626) ose@ricconnect.com
- [Willy's Electronic Supply](#) (National City, CA. (619)477-2119) willys@cts.com

Click a figure to pop up a larger view of that figure in a new window.



Interface Photo 1

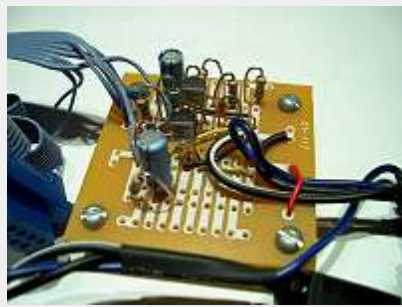

Interface Photo 2

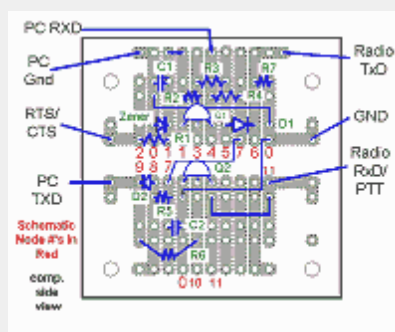

Component Placement Diagram

Other implementations

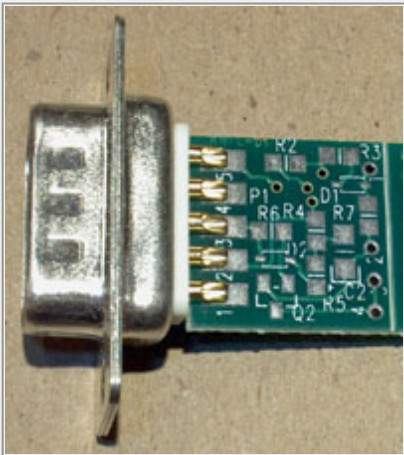

PT2RFL, Rubens Fiuza Lima, is a professional circuit board designer who designed this *tiny* two-sided surface-mount board (blank board shown here) which fits inside a DB-9. He had several PCB's fabricated. More photos [here](#).



Torbjörn Söderberg (SM4XDJ) in Sweden managed to fit the entire circuit board inside a DB-9 Clamshell-style connector for his TH-F7E (European version of the TH-F6A). More photos [here](#).

Torbjörn used R1= 150ohm and omitted R7, as in the original schematic mentioned [earlier](#).

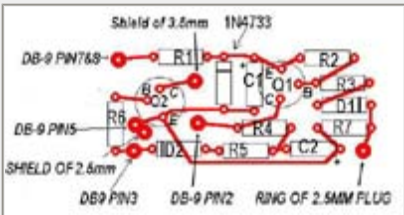

Bill Verstelle (N7OQ verst@pacbell.net) made a ~1" x 2" printed circuit board which he fit into a film canister.

Using the interface / software

1. For TH-G71: Menu 15, TC ON

Tranceiver Control must be enabled, or else you will get a communication timeout error when trying to communicate with the radio after connecting the cable up to your PC. "TC ON" enables the plugs on the side to work as data lines instead of as external mic/speaker.

Press the "F" button, and then Band, turn the main tuning knob to Menu 15 Transceiver Control and turn it ON for programming. You will need to use a free com port (Com 1 or 2) on the PC.

Note: For the TH-F6 radio, the Kenwood manual states: Access Menu No. 9 and select "PC"

2. Kenwood Programming software

Download the PC Programming s/w from Kenwood FTP site <ftp://ftp.kenwood.net> or web page <http://www.kenwood.net/amateur> -> downloads -> software -> THG71A

You should see the files mg71200.exe and readme.txt.

Install the software and Run mcp-g71.exe. go to file menu, and be sure your com port is set correctly, then turn on radio, and plug in, and do "Radio-> Read". Try it a few times -- I found that it sometimes said something like "Communication timeout" the first time I tried after connecting up the interface.

Debugging problems with the interface

1. Be sure you have done everything listed under ["Use"](#). If you are really stuck, you can try these checks:

2. **Verify power + side:**

- A. With the interface connected to the pc, connect a meter to node 1 (cathode of the Zener) and ground.
- B. In the MCP program, do radio->read (you should see "reading data from radio") As it is "trying" to read the radio, quickly check the voltage.
- C. The voltage should be about 4-5 Volts. This is needed to power the interface from the serial port.

*Note: The voltage at the RTS and CTS pins of the DB-9 connector will **NEGATIVE** when the Com port is inactive (when you are not trying to read or write to the radio with the software). But the voltage will go **POSITIVE** (about 9V on my PC) when the Com port is active.*

Condition	RTS/CTS Voltage
Com port idle, not reading/writing radio	about -6 to -12V
Com port active, reading/writing radio	about +6 to +12V

- D. If you don't have good power here, something is wrong. (This is why I increased R1 resistance from the original schematic - as the original lower value loaded my serial port down too much due to the diode at node 1).

You can power the interface externally:

Remove the rts/cts connections from the PC and just power node 1 with a battery or external power supply. This was the main problem I had getting my interface working (besides trying to figure out the pinouts of kenwood jacks).

3. **Verify power negative (-) side:**

- A. With the interface connected to the pc, connect a meter to node 7 (negative terminal of the Cap C2)
- B. In the MCP program, do radio->read (you should see "reading data from radio" As it is "trying" to read the radio, quickly check the voltage.
- C. The voltage should be negative (more negative than about -5 or -6V) This is needed to generate a negative voltage back to the PC RxD.

4. If this power is good in the previous steps, but the interface still does not work, recheck the interface to make sure everything is wired up correctly including all ground connections, and the pinouts the serial port DB connector. Check all part values and that the polarity of caps is correct, and that NPN and PNP transistor are wired up the correct way.

5. If that does not find any problems, I would then test the interface to be sure it does the correct level-shifting and "inversion" of the levels from the PC (RS-232) to lower-voltage for the Radio.

This can be a bit tricky and you need some power supplies and clips to do this, with the interface disconnected from the PC and the Radio.

Basically, you want to verify the following:

- A. With TXD (out from the radio) = 0V, the RxD to PC should be about 5V
- B. With TXD (out from the radio) = 3-5V, the RxD to PC should be between -5V to -12V.
- C. With TXD (out from the PC) between -5V to -12V, the RxD to the Radio should be "floating" (Q2 off) (and the weak pullup in radio pulls the node to a logic "high" value)
- D. With TXD (out of the PC) > 5V or so, the RxD to Radio should be 0V (Q2 is "on").

But the catch is that the interface generates the -12V (or so) by the switching on TXD. So you need to fake it out to be sure you have this voltage (which should be there in step 3c) because you don't have the interface connected to the PC anymore.

Otherwise, you won't get the negative voltage in step 5B.

Programming the TH-G71

See [this page](#) for information used to program and control the TH-G71 through a serial port. Serial Port command protocol is provided. This is useful if you are interested in how Kenwood's MCP memory control program works, or if you are interested in programming the radio using a PC.

Chris Koza [KB7QPK](#)

02-01-2002

(TH-F7) Extended TX Mods by G1IVG

Author: Colin - G1IVG - colinlowe@jet.es. MODIFICATION.NET

Notes:

This modification will reset your radio and therefore clear all pre-programmed memories etc.

If you have never removed surface mount devices before, then experiment on some old PCB's first, before destroying or making a mess of your new radio.

Make sure you use a low wattage soldering iron and tweezers to lift the components from the PCB.

If you decide to do this modification, you do entirely at your own risk.

1. Remove the battery from the radio.
2. Remove the grey rubber protective cover from the right hand side of the radio.



3. Remove the black plastic volume and frequency change knobs by gently pulling them vertically.
4. Remove the locking nut from the SMA aerial connector.
5. Remove the locking nut from the frequency change encoder / volume control shaft.



6. With the battery removed, look at the rear of the radio and remove the two screws at the bottom.



7. To open your radio's case. It's best to gently open the radio from the bottom until you have a gap of about 10mm. Then hold the front panel in the palm of your left hand and gently slide the main body of the radio downwards with your right hand, until the aerial and frequency change encoder shaft are clear of the holes in the top panel of the radio. Take care not to open the radio too fast, because the internal speaker wires are very short.



8. With the radio opened up like a book, look at the left hand side of the PCB just to the left of the PCB mounted microphone. You should see two diodes and also a open pad just below were another diode could be fitted.

These photo's shows radio before modification.



9. Remove only the top diode. There still should be a diode in the middle position and the bottom position should be left empty as original.
10. Finally look just below the lower open pad (3rd position) you should see a resistor to the left of the key pad number "1". This also must be removed to complete the modification.

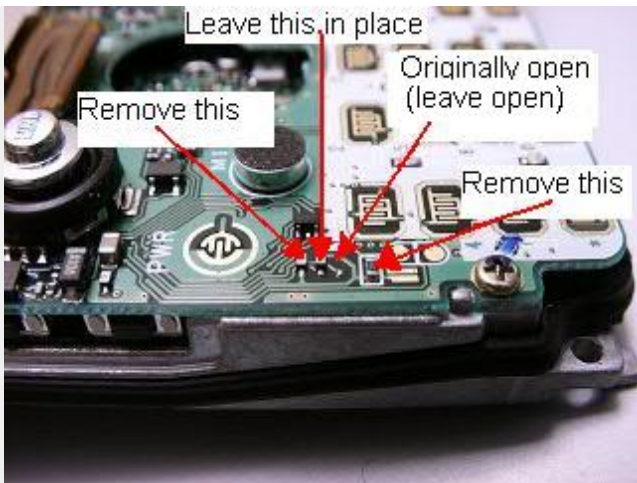

This photo shows radio after modification.

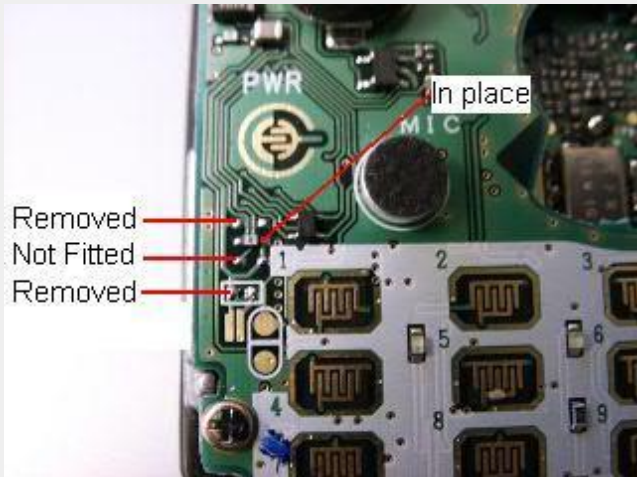

11. Reassemble the radio taking care not to trap the speaker wires and also check that the small joystick and keypad membrane seats correctly.

OK That's it.....

The TH-F7E will now Transmit and Receive on the "A" band from:

137MHz to 174MHz FM.

410MHz to 470MHz FM.

Warning.

Always use a tuned aerial for the frequency you intend to transmit on, as the original supplied aerial is only designed for use on our amateur 2m and 70cms bands.

If your aerial is not tuned for the frequency you wish to transmit on, damage to the PA in the radio can be caused if you transmit on high or even low power.....You have been warned!!!!

Date: 24-03-2002 **User comment** **From:** [dg5mec](#)

Subject: Warning Kenwood TH-F7 extended TX

I have one little warning when using an F7 with extended TX range. Transmitting in the upper 2m band (above 160 MHz or so) with a non-resonant antenna (like the original antenna is in this range) can fry the UHF(!) RX preamp transistor.

It is an GaAs-Fet (seems to be an 3SK299), an replacement is difficult to find.
 I had three defective transceivers, all with rx sensitivity around 1 uV at 430 MHz, and although there is no evidence that really this was the reason it is almost for sure that the owners fried their F7 this way!

Date: 26-03-2002 **User comment** **From:** [dg5mec](#)

Subject: Replacement found.

I even fried my own radio this way, but I was able to fix it;

Replaced the 3SK299 with a CF739, unfortunately this one has a bigger housing and was a bit hard to get in place, but now the radio is like new (with the tester even a bit more sensitive, but in all-days use just identical to the original state), and this transistor seems to be more robust, I was up to now not able to kill it any more :)

19-07-1998

(TH-G71A) TH-G71A Beyond Mars modification

Author: Jerry, KK6YO

11/03/97

This modification is provided "as is" and is subject to change without notice, Kenwood Service Corporation (Nor I) make any warranty of any kind with regards to This modification procedure, including, But not limited to, the implied warranties of merchantability and fitness for any purpose. Kenwood Service Corporation(And I) shall not be liable for any error or for incidental or consequential damage in conjunction with the furnishing, performance, or use of this modification procedure.

Modification procedure.

1. Remove The battery Pack and antenna.
2. Open the SPKR/MIC dust cover.
3. Remove the three screws from the back panel of the transceiver
4. Carefully lift up the bottom end of the back panel and pull the entire back panel towards the bottom of the transceiver to clear the antenna connector from The top pnnel. Do not break the ribbon cable That connects the back panel PCB to the front case PCB.
5. Set the back panel to the left side of the front case.
6. Locate and remove diode D512 and D513 from the bottom right side of the front case PCB.
7. Assemble the transceiver by reversing the steps listed above. The transciever will automatically reset when turned on.

TX Capability.

136.000 - 173.995MHz 400.000 - 469.995MHz

RX Capability.

118.000 - 173.995MHz , 400.000 - 469.995MHz
320.000 - 399.99375MHz , 800.000 - 823.9875MHz
849.000 - 868.9875MHz 894.000 - 949.9875MHz

Note: This change also allows the transceiver to access a previously suppressed menu number 16. this menu allows the transceiver to switch between FM and AM in the 118Mhz- 136.000MHz range.

Another Note: If you only want to expand the RX,Remove D512 ONLY.
For MARS/CAP TX expand only, cut the green wire(W500)ONLY.

Here is a drawing of the radio. (Which tells you just about everything you need to know.)

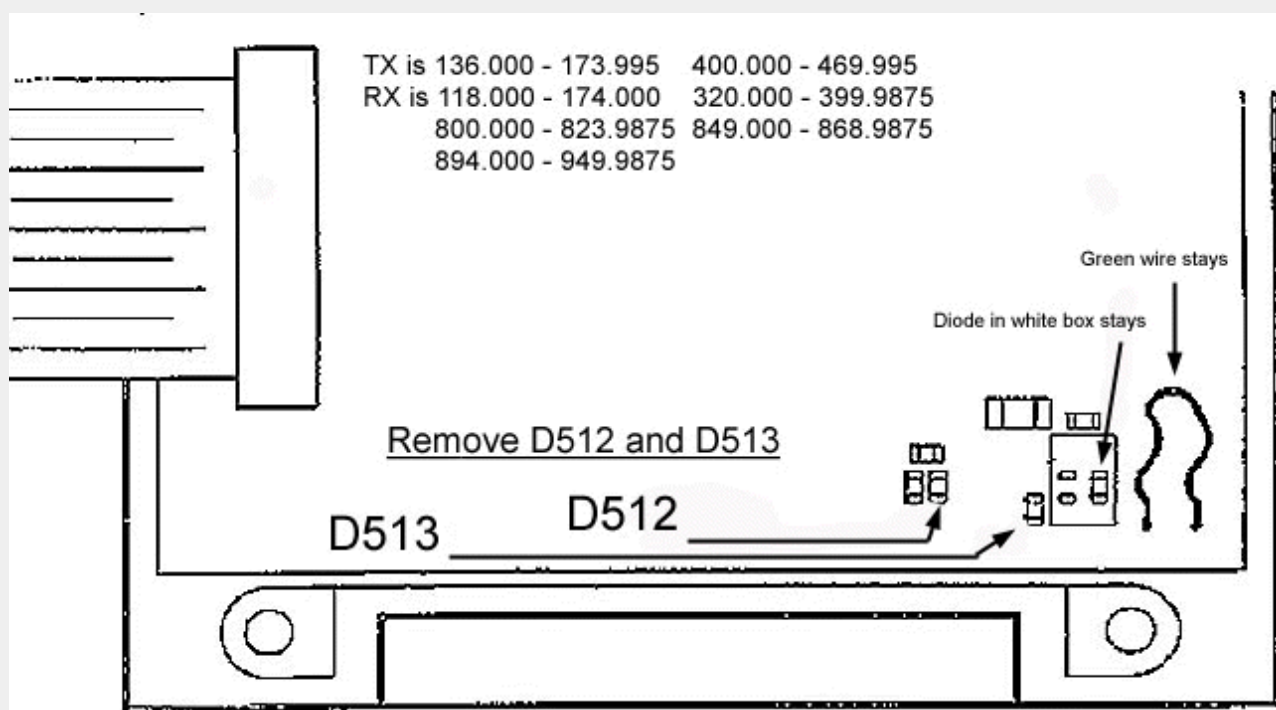

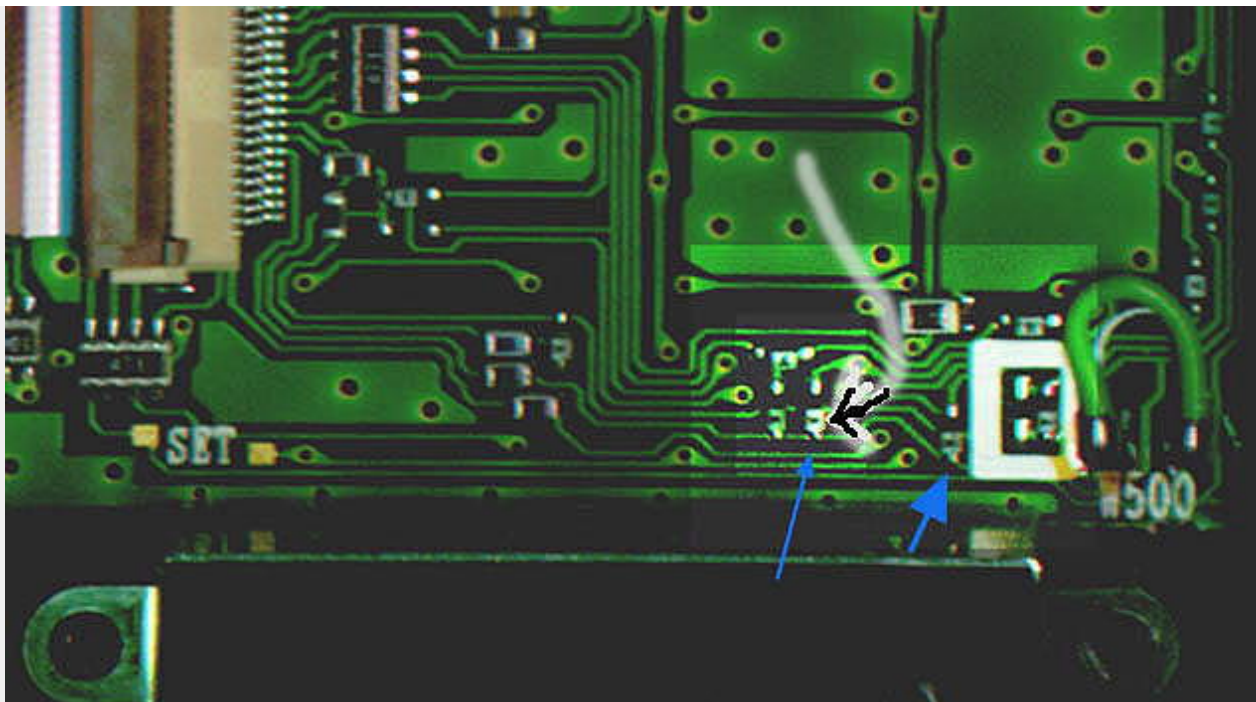

Date: 08-09-2001

User comment

From: [Mark](#)

Subject: Soldering tip

For those who want to do this mod, but haven't the steadiest of hands for micro soldering, here's how I did it:

I removed the tip from my 15 Watt pencil iron (Radio Shack one with the blue handle), bent a small needle around the screw that holds the tip in, and secured it. I bent the other end down for the sake of not having anything else touch the radio. I secured the gun with those "Helping Hands" that Radio Shack sells (Those alligator clips on movable arms, with a heavy base).

Once heated up, I took another pin (One with a larger head for maneuverability), and pried up the diode. Worked great! I can't believe the sensitivity on 800 trunking! I only did the receive mod (D512). The transmit mod made no sense to do, since transmitting outside of the Amateur Bands is illegal.

Note: Your radio **will** reset when powered up. Write down your memories, or if you have the computer interface, do a save. Remember, if you are doing the computer programming, to set menu item #15 to "on", since computer control is defaulted off.

Also, the usual disclaimer: Use this info at your own risk. Your warranty can be voided by improper procedure of attempting this mod. If you aren't sure you can complete this mod on your own, have someone do it for you. I won't be responsible for a cooked radio.

73/Mark/W4KSR.

This modification is read 2440 times.

[top of page](#)

28-01-2002

(TH-G71A) PC-programming cable for Kenwood TH-G71A / TH-F6A

Author: azkoza@yahoo.com - KB7QPK.MODIFICATION.NET

*Note: The interface described here has been verified to work on the TH-G71 and also the the TH-F6A/TH-F7E.

- [Background](#)
- [Plug pinout](#)
- [Schematic](#)
- [Building a homemade interface](#)
- [Implementations built by other hams](#)
- [Using the interface / Software](#)
- [Debugging problems with the interface](#)
- [Programming the radio with a PC](#)



Background

I wanted to make my own cable to program my Kenwood TH-G71A ham radio with a PC, but the owner's manual simply did not show the pinout needed for the connector plugs. I searched the web but was not able to find this information but I did discover that several other radios used an RS-232-to-logic (0-3.3V) level-shifter and a Full-duplex serial connection (separate RXD / TXD), and found schematics for such interfaces for other radios. I also found a device called the "[MAK interface](#)" which claimed to work with the TH-G71A, and the web site listed an interface cable.

With these clues, and after studying the signals coming out of the radio (and lots of debug time ...), I finally figured out the plug connections at the radio end.

I was able to use basically the same interface schematic that was claimed to work for the Kenwood PG-4S cable (which is used for the TM-G707 / TM-V7 radios instead of the Kenwood TH-G71).

Refer to <http://www.fiberpipe.net/~tateb/pg4s.html> for the schematic for the PG-4S interface:

The DB-9 connector to the PC is the same, but the connector on radio side is different. (Instead of the 6-pin mini-DIN connector, use the 2.5mm and 3.5mm phono plugs for the TH-G71)

Refer to Drawing at the URL above (Tate Belden's site), right hand side, starting at the top:

1. Ignore the tie between pins 4 and 5 of the mini-DIN connector. (There is no such tie on the TH-G71 Cable)
2. The interface's "TXD" goes to Ring of 2.5mm plug. (cathode of the diode on the interface)
3. The interface's "RxD" goes to the Shield of 3.5mm plug. (collector of NPN on interface) (Or just use a mono 1/8" jack and connect this to the shield!)
4. GND goes to shield of the 2.5mm plug.
5. The tips of both plugs are No-connect.

Schematic tweaks:

Note: If you have an interface that already works on another radio such as the Kenwood TM-G707 / TM-V7, then you may not need to make these changes!

1. Change R1 from 150ohm to 1K ohm (this is the resistor feeding the zener diode). I found that 150ohms loaded the line too much and the resulting voltage was too low to power the interface from the Serial port. If you have problems, be sure that the cathode of the Zener is at about 4.9V. I found that the interface worked down to about 3.2V when I just powered this from a variable power supply instead of through the PC serial port (after removing R1 and the zener and just applying voltage at C1)
2. add a 150K ohm resistor between the Radio TXD to gnd. I did this just to keep the voltage down on the TxD pin because the radio seems to be 3.3V I/O pin (not 5V)

TH-G71 PC cable interface plugs.

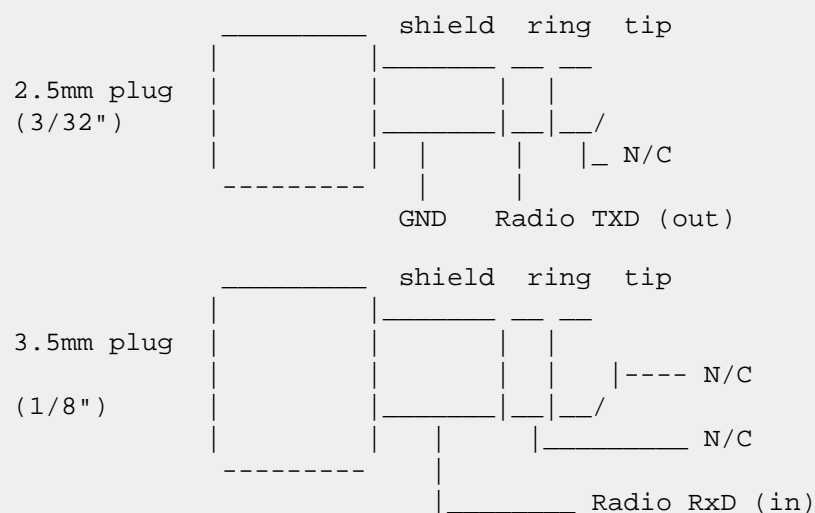

Update: Dec 2001: The Kenwood manual for the newer TH-F6 radio shows the pinout for the Plugs (page 46). Through Dec 17, 2001, this web page showed the Ring and Shield of the 3.5mm plug both shorted together, but I have updated the plug pinout to match the Kenwood documentation, and I confirmed that it does work as shown, without the connection to the ring.

I was able to find a 90-degree "elbow" shaped, 2.5mm stereo plug at Radio Shack (p/n 274-298).

Here is the resulting schematic:

PC programming cable for TH-G71A radio.
 Jan 28, 2001. g71cbl2.cir
 Verified working.

Parts:
 1N4733: 5.1V Zener Diode
 C1, C2: 1uF, 16V electrolytic
 D1, D2: 1N4148
 Q1: PNP Switching (2N3906)
 Q2: NPN Switching (2N3904)

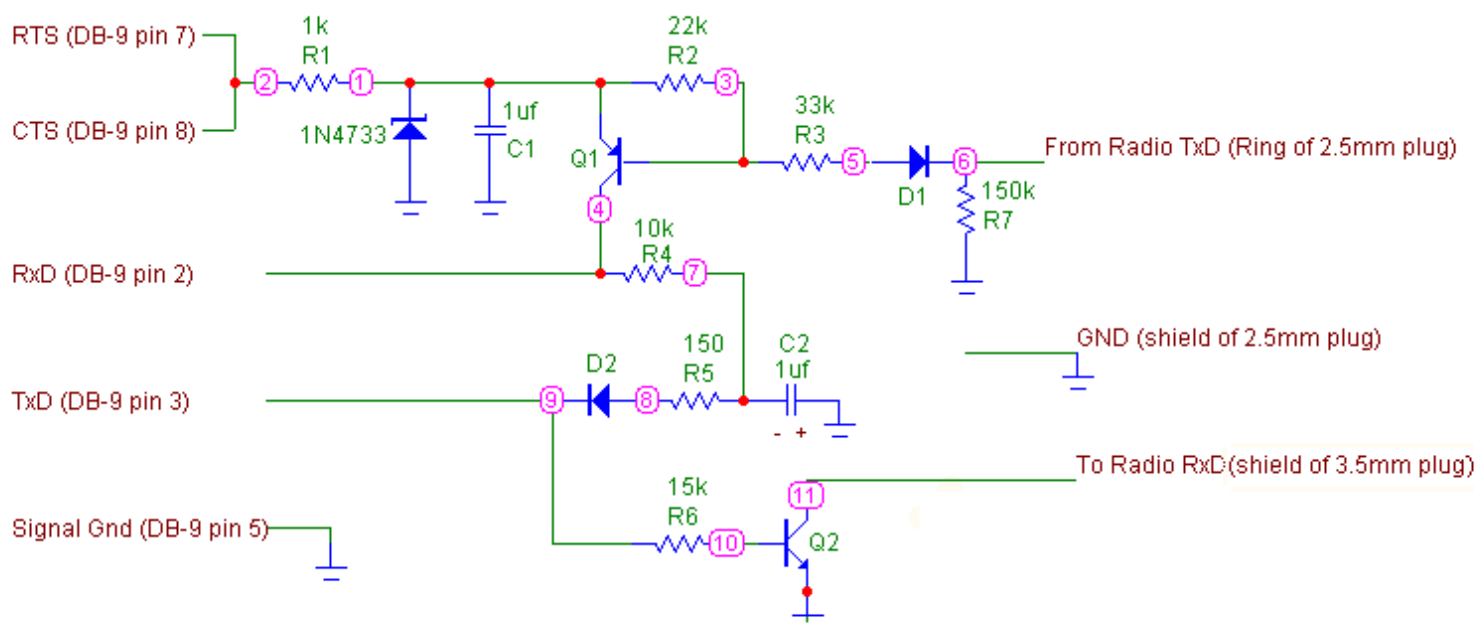

Notes:
 1. This is a level-shifter converting RS-232 <=> Logic (0-3.5V) levels.
 2. Tip of 2.5mm plug and tip of 3.5mm plug (to radio) are No-connect
 3. Kenwood G71 has internal pullups to 3.5V on RXD and PTT signals.

Disclaimer: Although this works fine for me, use at your own risk.

Building it - my homemade interface

I built the interface on a Small PC board originally purchased from [Circuit Specialists](#) , Mesa, AZ.

It is "[Datak](#)" brand prototyping board part number 12-607.

([RadioShack.com](#) carried them as p/n 910-3811 (in their catalog) but I don't see them on-line anymore.)

A recent [Google Search](#) on *datak 12-607* found the following as possible sources:

- [Ocean State Electronics](#) (Westerly, RI. (800)866-6626) ose@ricconnect.com
- [Willy's Electronic Supply](#) (National City, CA. (619)477-2119) willys@cts.com

Click a figure to pop up a larger view of that figure in a new window.



Interface Photo 1

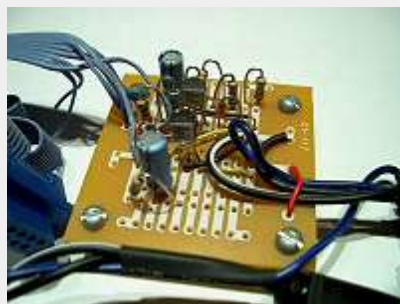

Interface Photo 2

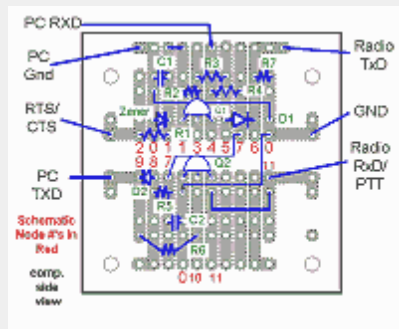

Component Placement Diagram

Other implementations

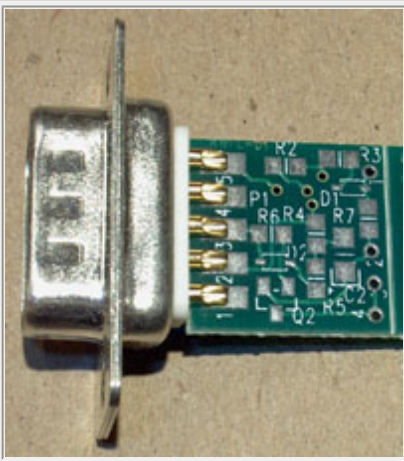

PT2RFL, Rubens Fiuza Lima, is a professional circuit board designer who designed this *tiny* two-sided surface-mount board (blank board shown here) which fits inside a DB-9. He had several PCB's fabricated. More photos [here](#).



Torbjörn Söderberg (SM4XDJ) in Sweden managed to fit the entire circuit board inside a DB-9 Clamshell-style connector for his TH-F7E (European version of the TH-F6A). More photos [here](#).

Torbjörn used R1= 150ohm and omitted R7, as in the original schematic mentioned [earlier](#).

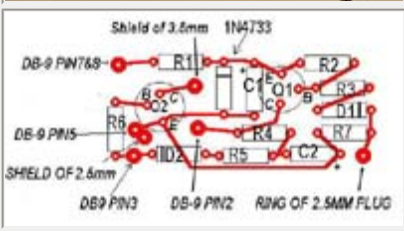

Bill Verstelle (N7OQ verst@pacbell.net) made a ~1" x 2" printed circuit board which he fit into a film canister.

Using the interface / software

1. For TH-G71: Menu 15, TC ON

Tranceiver Control must be enabled, or else you will get a communication timeout error when trying to communicate with the radio after connecting the cable up to your PC. "TC ON" enables the plugs on the side to work as data lines instead of as external mic/speaker.

Press the "F" button, and then Band, turn the main tuning knob to Menu 15 Transceiver Control and turn it ON for programming. You will need to use a free com port (Com 1 or 2) on the PC.

Note: For the TH-F6 radio, the Kenwood manual states: Access Menu No. 9 and select "PC"

2. Kenwood Programming software

Download the PC Programming s/w from Kenwood FTP site <ftp://ftp.kenwood.net> or web page <http://www.kenwood.net/amateur> -> downloads -> software -> THG71A

You should see the files mg71200.exe and readme.txt.

Install the software and Run mcp-g71.exe. go to file menu, and be sure your com port is set correctly, then turn on radio, and plug in, and do "Radio-> Read". Try it a few times -- I found that it sometimes said something like "Communication timeout" the first time I tried after connecting up the interface.

Debugging problems with the interface

1. Be sure you have done everything listed under ["Use"](#). If you are really stuck, you can try these checks:

2. Verify power + side:

- A. With the interface connected to the pc, connect a meter to node 1 (cathode of the Zener) and ground.
- B. In the MCP program, do radio->read (you should see "reading data from radio") As it is "trying" to read the radio, quickly check the voltage.
- C. The voltage should be about 4-5 Volts. This is needed to power the interface from the serial port.

*Note: The voltage at the RTS and CTS pins of the DB-9 connector will **NEGATIVE** when the Com port is inactive (when you are not trying to read or write to the radio with the software). But the voltage will go **POSITIVE** (about 9V on my PC) when the Com port is active.*

Condition	RTS/CTS Voltage

Com port idle, not reading/writing radio	about -6 to -12V
Com port active, reading/writing radio	about +6 to +12V

D. If you don't have good power here, something is wrong. (This is why I increased R1 resistance from the original schematic - as the original lower value loaded my serial port down too much due to the diode at node 1).

You can power the interface externally:

Remove the rts/cts connections from the PC and just power node 1 with a battery or external power supply. This was the main problem I had getting my interface working (besides trying to figure out the pinouts of kenwood jacks).

3. Verify power negative (-) side:

- A. With the interface connected to the pc, connect a meter to node 7 (negative terminal of the Cap C2)
 - B. In the MCP program, do radio->read (you should see "reading data from radio" As it is "trying" to read the radio, quickly check the voltage.
 - C. The voltage should be negative (more negative than about -5 or -6V) This is needed to generate a negative voltage back to the PC RxD.
4. If this power is good in the previous steps, but the interface still does not work, recheck the interface to make sure everything is wired up correctly including all ground connections, and the pinouts the serial port DB connector. Check all part values and that the polarity of caps is correct, and that NPN and PNP transistor are wired up the correct way.
 5. If that does not find any problems, I would then test the interface to be sure it does the correct level-shifting and "inversion" of the levels from the PC (RS-232) to lower-voltage for the Radio.
This can be a bit tricky and you need some power supplies and clips todo this, with the interface disconnected from the PC and the Radio.

Basically, you want to verify the following:

- A. With TXD (out from the radio) = 0V, the RxD to PC should be about 5V
- B. With TXD (out from the radio) = 3-5V, the RxD to PC should be between -5V to -12V.
- C. With TXD (out from the PC) between -5V to -12V, the RxD to the Radio should be "floating" (Q2 off) (and the weak pullup in radio pulls the node to a logic "high" value)
- D. With TXD (out of the PC) > 5V or so, the RxD to Radio should be 0V (Q2 is "on").

But the catch is that the interface generates the -12V (or so) by the switching on TXD. So you need to fake it out to be sure you have this voltage (which should be there in step 3c) because you don't have the interface connected to the PC anymore. Otherwise, you won't get the negative voltage in step 5B.

Programming the TH-G71

See [this page](#) for information used to program and control the TH-G71 through a serial port. Serial Port command protocol is provided. This is useful if you are interested in how Kenwood's MCP memory control program works, or if you are interested in programming the radio using a PC.

Chris Koza [KB7QPK](#)

This modification is read 798 times.

[top of page](#)

02-12-1999

(TH-G71E) TH-G71E repeater shift

To modificate a TH-G71E, you just have to cut the green wire as you can see at the photo from the TH-G71A. Now you can send and receive just like the A, but with european repeater shift!

This modification is read 1568 times.

[top of page](#)

30-04-2000

(TH-G71E) Il nuovo KENWOOD TH-G71E by HB9OAE

Author: Maico Kelly - hb9oae@bluewin.ch.MODIFICATION.NET

Nuovo ricetrasmittitore palmare VHF/UHF a doppia banda Tastiera illuminata e memoria alfanumerica Menu' di sistema Un ulteriore aiuto all'operatore e' fornito dal menu' di sistema in grado di controllare con facilita' tutte le funzioni disponibili.

Potenza e prestazioni elevate Grazie all'antenna dalle elevate prestazioni, e' in grado di erogare fino a 6 W (VHF) 5,5 W (UHF) con alimentazione diretta a 13,8 V cc.

E' inoltre possibile regolare la potenza RF su 3 livelli.

200 canali multifunzioni In ogni canale e' possibile registrare tutti i valori di frequenza, shift, dicitura alfanumerica.

CTCSS encoder/decoder di serie.

MIL STD810E rispondente alle severe norme MIL STD810E. memorie DTMF , e' possibile memorizzare l'apparato tramite PC.

APO funzione di autospegnimento.

TIMER di fine trasmissione.

Circuito economizzatore di batteria.

PREZZO: £. 730.000 da www.radiosystem.it , da www.radaufunk.com SFR. 440.-

MODIFICA ricevuta da IW4BMP

Esiste una modifica unica che provvede ad allargare la banda operativa sia in ricezione che in trasmissione per il TH-G71. Occorre aprire l'apparato facendo attenzione al flat cable che trattiene la parte frontale con quella posteriore, nella parte frontale, all'interno, individuare un ponticello di filo verde (di solito) situato nell'angolo del circuito stampato in basso a destra. Richiudere l'apparato eseguire un reset ed ora é pronto per trasmettere: 136/174 e 400/470 mHz e ricevere : 118/136 in AM 320/400 800/950 FM.

Buon divertimento e 73s' de hb9oae@uska.ch.MODIFICATION.NET maico.

This modification is read 1465 times.

[top of page](#)

13-11-2000

(TK-240) Kenwood TK-240 programmed with 16 channels

Author: Thomas Scherrer-Tangen

This Kenwood handie can be programmed with 16 Channels in the VHF band.

Full RX and TX from about 130MHz to 170MHz, with a resolution of 6.25 KHz.

It can also transmit a pilot (subtone) also programable.

Programming instructions:

- Remove the small black plastic sticker, then 4 holes with 4 small PCB contacts can be seen.
- Turn radio off
- make contact in hole 2 (see picture)
- and press the SQ open key,
- at the same time turn radio on.

Now ALL channels has been erased at radio is reset.

Display shows 1 150 0000, the first small 1 is the channel, then the RX freq is 150.0000 MHz.

- Now use the channel button to adjust to the disired freq, pres the Light button for 1 MHZ range when adjusting.
- Now save RX freq in channel 1 with the TX button, display show 1 ----- now same procidure for the TX freq.
- then pres TX again and OFF shows in the display, this is the pilot tone. adjust to the disired freq and press TX.
- now Channel 2 shows.... go on to END shows, turn off and on again.. done.

Enter EDIT mode:

- Turn radio off
- make contact in hole 2
- and press the LIGHT key,

Now you can see all freqs and edit whay ever you want, use TX as the enter key.



[Thomas Scherrer-Tangen](#)

This modification is read 1116 times.

[top of page](#)

23-11-2001

(TK-270) TK370/270 high-band h/t radio instructions

Author: Etchenique Fabian - FETCHENIQUE@agr.com.ar MODIFICATION.NET

To place unit in programming mode: With power OFF, hold down the ! button (upper side button above PTT (Push-To-Talk) key with a square molded on it) with left index finger and the DIAL button with left thumb. Turn on unit. Hold buttons down until SEL appears on the display. Release buttons. Press TA button. CH 1 will appear in display. Unit is now in programming mode.

To program (change) frequencies in any of the 32 channel positions: Use the rotary channel selector knob to scroll to the desired channel position (CH 1 through CH 32). Press the PTT key on the left side of the unit. The channel's receive frequency will be displayed. To change the frequency in small increments: use the rotary channel selector knob to move up or down. To change the frequency in 1 MHz (large) increments, press and hold the ! button and use the rotary channel selector knob to scroll up or down in 1 MHz increments. The same method is used to alter transmit frequencies.

Programming sequence 'positions' for each channel (controlled by pressing the PTT key while in programming mode and on the desired channel). Repeated PTT pressing is known as scrolling.

- 1st - press of the PTT key - Receive frequency,
- 2nd - Receive tone,
- 3rd - Transmit frequency, 4th - Transmit tone,
- 5th - (off),
- 6th - (off),
- 7th - Channel in/out of scan list (Add or dEL),
- 8th - (off),
- 9th - (off),
- 10th - Transmit power (H) = high.

Tones - sub-audible tones are used to eliminate the reception of undesired signals or to allow access to specific repeater sites (tones 1 through 8, listed on channel card). Displayed numbers are the tone frequency, in Hz (cycles per second).

To program/modify tones: while tone status is displayed (by scrolling to position 2 for receive tone or 4 for transmit tone) in the programming sequence, either rotate the channel selector knob until the desired tone is displayed or use the LO key to turn the tone function OFF or enable the programming of the tone function (display the tone) from OFF. Note: The display of 023 is not a valid tone and should be scrolled past and not be used.

To leave programming mode, use the PTT key to scroll until CH 1 through CH 32 or OFF is displayed. Turn radio off. Unit is ready to be used when it is turned on again.

Non-Programming mode Functions

To add or delete a channel from the scan list: scroll to the desired channel (using the rotary channel knob). Press and hold the lower side button (below the ! button) and press the SCN button. Release the buttons. A small "A" displayed above the channel number indicates that the channel is in (added) to the scan list.

Squelch adjustment: To increase the squelch level (to eliminate interference) or lower the squelch level (to receive weak transmissions), first ensure that the .scan mode is off. Press and hold down the lower side button (below the ! button) and then press the LO button. Release the side button. Unit is now in squelch adjustment mode (with Sql displayed). Squelch level is from 0 (unsquelched) to 9 (full squelch). 4 to 6 is normal range. Use rotary channel selector knob to scroll to desired setting. Pressing the LO key will exit the squelch adjustment mode.

To enter the 'car-to-car' (direct/talk-around/non-repeater) mode, press the TA button. tA (and the channel number) will be displayed. To exit, press the TA button again.

To illuminate the display window: press the ! button. Press the button again to turn the lamp off.

This modification is read 808 times.

[top of page](#)

27-03-2000

(TK-340) TK340 Programming Information

Author: Colin G1IVG - colinlowe@jet.es.MODIFICATION.NET

(UHF 16 Channel FM Transceiver)

1. Remove black plastic sticker from the rear panel of the radio at the top to expose a row of four gold coloured contacts
2. Locate the third one from the left-hand side
3. Using a small piece of wire short out the inner connection to the outer connection.
4. With the connections shorted and the radio turned off press and hold the lamp button (the lower most button located on the left hand side of the radio looking from the front view) and turn on the radio.
5. The display will show the receive frequency of channel 1 using the dial knob (located at the top of the radio on the right hand side looking from the front view) rotate this to give the required frequency.
6. If you require fast tuning press and hold the function button (located on the left hand side looking from the front of the radio) whilst rotating the dial knob.
7. As you press the PTT button (located on the left hand side of the radio the largest button located in the centre of the three buttons) the radio will then display the RX CTCSS tone frequency, to select the required tone rotate the dial knob.
8. Next press the PTT switch and the radio will display the TX frequency tune as previously explained as you did for tuning the RX frequency.
9. Press the PTT switch again and it will display the TX CTCSS tone, set up as you did for the RX CTCSS and then press the PTT switch, do this for, as many channels are required.
10. To skip programming channels press the PTT switch 4 times to go to the next channel.
11. Repeat this until you see on the display a message, which reads "END", now turn off the radio.
12. Turn the radio on again and your radio is now programmed.

Depending on the original frequencies programmed into the radio you may need to adjust the VCO, good luck

This modification is read 1123 times.

[top of page](#)

23-11-2001

(TK-370) TK370/270 high-band h/t radio instructions

Author: Etchenique Fabian - FETCHENIQUE@agr.com.ar.MODIFICATION.NET

To place unit in programming mode: With power OFF, hold down the ! button (upper side button above PTT (Push-To-Talk) key with a square molded on it) with left index finger and the DIAL button with left thumb. Turn on unit. Hold buttons down until SEL appears on the display. Release buttons. Press TA button. CH 1 will appear in display. Unit is now in programming mode.

To program (change) frequencies in any of the 32 channel positions: Use the rotary channel selector knob to scroll to the desired channel position (CH 1 through CH 32). Press the PTT key on the left side of the unit. The channel's receive frequency will be displayed. To change the frequency in small increments: use the rotary channel selector knob to move up or down.

To change the frequency in 1 MHz (large) increments, press and hold the ! button and use the rotary channel selector knob to scroll up or down in 1 MHz increments. The same method is used to alter transmit frequencies.

Programming sequence 'positions' for each channel (controlled by pressing the PTT key while in programming mode and on the desired channel). Repeated PTT pressing is known as scrolling.

1st - press of the PTT key - Receive frequency,
2nd - Receive tone,
3rd - Transmit frequency, 4th - Transmit tone,
5th - (off),
6th - (off),
7th - Channel in/out of scan list (Add or dEL),
8th - (off),
9th - (off),
10th - Transmit power (H) = high.

Tones - sub-audible tones are used to eliminate the reception of undesired signals or to allow access to specific repeater sites (tones 1 through 8, listed on channel card). Displayed numbers are the tone frequency, in Hz (cycles per second).

To program/modify tones: while tone status is displayed (by scrolling to position 2 for receive tone or 4 for transmit tone) in the programming sequence, either rotate the channel selector knob until the desired tone is displayed or use the LO key to turn the tone function OFF or enable the programming of the tone function (display the tone) from OFF. Note: The display of 023 is not a valid tone and should be scrolled past and not be used.

To leave programming mode, use the PTT key to scroll until CH 1 through CH 32 or OFF is displayed. Turn radio off. Unit is ready to be used when it is turned on again.

Non-Programming mode Functions

To add or delete a channel from the scan list: scroll to the desired channel (using the rotary channel knob). Press and hold the lower side button (below the ! button) and press the SCN button. Release the buttons. A small "A" displayed above the channel number indicates that the channel is in (added) to the scan list.

Squelch adjustment: To increase the squelch level (to eliminate interference) or lower the squelch level (to receive weak transmissions), first ensure that the .scan mode is off. Press and hold down the lower side button (below the ! button) and then press the LO button. Release the side button. Unit is now in squelch adjustment mode (with SqL displayed). Squelch level is from 0 (unsquelched) to 9 (full squelch). 4 to 6 is normal range. Use rotary channel selector knob to scroll to desired setting. Pressing the LO key will exit the squelch adjustment mode.

To enter the 'car-to-car' (direct/talk-around/non-repeater) mode, press the TA button. tA (and the channel number) will be displayed. To exit, press the TA button again.

To illuminate the display window: press the ! button. Press the button again to turn the lamp off.

This modification is read 839 times.

[top of page](#)

22-03-2002

(TK-705) Revised TK-705D & TK-805D programming

Author: KC7GF - kc7gf@aol.com. MODIFICATION.NET

Beginning with SN 41200000 several new programming features were included in these models. These new features include a programmable Monitor Switch function, OFF-HOOK Scanning. OFF-HOOK decode, Transmit Revert Channel (for off-hook scanning), and an additional Scan Resume Delay (for the transmit revert channel). This Service Bulletin is revised to include the programming procedure for these new features in the self-programming mode.

Entering the self programming mode is accomplished by turning on the power switch while pressing a combination of buttons which act as an interlock. Jumper CN-8 located on the main board behind the display is in the SET position when the radio is shipped from the factory. This enables self programming. If CN-8 is moved to the USE position, which is recommended prior to delivering the radio to the customer, the self programming mode cannot be entered. (The radio may be operated with the jumper in the set mode, but after exiting programming mode it will revert back to displaying channel numbers, not frequencies.)

Prior to initial programming, you may want to perform a Memory Clear. With CN8 in the set mode: SIMULTANEOUSLY press and hold the AUX. and SCAN and D/A while turning the power switch ON". This will remove any frequencies which were factory installed for testing purposes. The radio automatically enters the Option setting mode during memory clear.

To enter the Option Setting Mode without clearing memory, SIMULTANEOUSLY press and hold AUX and SCAN buttons while turning power ON (CN-8 on the main board must be in the set position).

OPTION SETTING MODE

(Pressing PTT between all functions stores the data and changes to next function)

Function	Display	Rotate channel selector to select	Press
1 Band range	150.000~	100Mhz SECTION (150-450)	PTT
2 Time out timer	t OFF	Off-30-60-90-120-180 Sec (default=off)	PTT
3 Busy ch lockout	b On	Off/on (default = on) no TX when channel is busy	PTT
4 DEL/ADD condition	dA On	On=user select, off=fixed see RX ch & DEL/ADD	PTT
5 Mic hook operation'	H On	On=scan on hook, PTT off hook, mon off hook, Off=no scan, ptt on or off hook, no off hook monitor	PTT
6 Priority channel	P FI	FI=FIXED US=user selectable (default=fixed)	PTT
Additional features from sn 41200000			
7 Monitor switch	En On	On=press to disable decode, hold to disable Sq. Off=press to disable Squelch (default = on)	PTT
8 Off hook monitor	dE Off	On= no off hook monitor, off=monitor off hook	PTT
9 Off hook scan	sc Off	On= off hook scan, off=scan on hook only	PTT
10 END	END	(turn off power)	

RECOMMENDATIONS for NEW FEATURE SELECTIONS.

- Off Hook Monitor (dE OFF) is only enabled when On-Hook Scan is selected (SC=OFF)
- The "Last Called" option in the revert channel selection is supported in units bearing SN of 50700000 and higher only. Prior to this S/N, the "Last Called revert feature operated according to specifications outlined for certain export models only.
- The Revert channel during On-Hook scanning is the Priority channel only. The revert channel and Resume B selection is skipped during self programming when On Hook scanning is selected.

In the user mode, the display skips unprogrammed channels. During programming mode any mistakes in programming can be reprogrammed over but channels cannot be deleted once entered unless memory is cleared, and all desired information reprogrammed. When all desired tone and frequency entries are completed, continue pressing PTT (stepping across unprogrammed channels) until END is displayed. If any undesired channels were displayed prior to END, the memory must be cleared and reprogrammed. (memories may be cleared individually when using the KPG6D programming software by hitting all spaces.

FREQUENCY PROGRAMMING MODE

TK-705D AND TK-805D FREQUENCY, AUXILIARY & SCAN Programming

To enter the frequency programming mode, SIMULTANEOUSLY press and hold the "AUX and "D/A buttons while turning power "'ON" (CN-8 on the main board must be in the SET position)

CH1 - RX FREQ

Set ch1 RX freq by turning channel selector, hold AUX key when turning to change 1mhz

Press SCAN to change channel step from 10 and 12.5kc UHF or 5 and 6.25kc VHF

Press D/A key to enable delete/add scan function for this channel

Press REC to enable AUX switch function on this channel (selected later) PTT

RX TONE TYPE

Use ch selector to set RX tone type, QT (tone) or DQT (digital) DQT only on D model PTT

RX TONE FREQ

Display reads St for tone or S dt for digital

Set receive tone or digital with ch selector=.1hz, Ch sel+AUX for 1's digit, REC for 10's digit on tone. For digital, ch selector = 1's, AUX +ch sel = 10's, REC+ch sel = 100's, SCAN=normal/ inverse (note that non-standard tones can be selected for both tone or digital) PTT

TX FREQUENCY

Note: when TX settings are being programmed the TX symbol (--^) will be displayed

Use ch selector to set TX freq (or press PTT to set no tx (RX only channel), Ch sel+ AUX= 1mhz

Use SCAN button to set step size (see above, same as RX) PTT

TX TONE TYPE

Set TX tone type (see above)

TX TONE FREQ

Set tone freq (see above) PTT

-----> Repeat the above for CH2 to CH16 (bypass any channel by pressing PTT on blank "----.----" channel.)

AFTER CHANNEL 16, PROGRAMMING ENTERS OPTION SELECT MENU (use Channel Sel to select option) AUX Set AUX button function, DRS=digital recording (must have option board), 2tonE= two tone sequential decode, dt=DTMF, tA= talkaround. Only one AUX condition can be set for all channels, however it can be turned on or off for specific channels in operation mode. PTT

RESUME A TIME

Set resume scanning delay time after receiving call in .5 second steps, PTT

RESUME B TIME

Set delay before scanning resumes after transmitting (in off hook scan mode) .5 sec, PTT

FIXED PRI CH

If option setting for priority is set at FI, fixed priority, select ch number, if set at US (user selectable) this will be skipped during programming, PTT

LOOKBACK A TIME

This sets the time between samples when looking back at the priority channel PTT

LOOKBACK B TIME

This sets the time between samples when looking back at the priority channel when the priority channel is busy but the signal does not have the PL tone you have programmed into the priority channel. PTT

REVERT CH (only enabled during off hook scan)

Use ch sel to set the channel the transmitter will revert to when PTT is pressed during off hook scan.

St = last channel selected before the scan switch was pressed

P CH = priority channel

CA CH = last channel a call was received on

US CH = last channel used (that was transmitted on) before scan switch was pressed PTT/ END

In programming mode pressing the MON (SPKR symbol) button and turning the channel selector knob will take you back or forward in the menu selections in case you make a mistake or decide to make changes to previous settings while programming. In operation mode, to add/delete channels for scanning, press scan and add/delete button.

Adjustment pots on theTK705D/805D, facing front of radio, left to right back row.

VR4=max deviation set , VR3=Mic sensitivity set , VR7=dig waveform bal (set for squarest digital waveform as seen at output frequency on service monitor), VR6=PL tone level (500 to 750 ~), VR5=power out (set to 27W) right side of silver VCO box VR1=preset squelch level, VR2=ABTO (this is the level control when using the digital audio recording option board).

TC1= frequency (TCXO) adjustment (NOTE: THIS IS ONLY ON THE 705D, THE 805D FREQUENCY ADJUSTMENT IS LOCATED ON THE TCXO MODULE WHICH IS TO THE RIGHT OF THE SILVER VCO BOX TC1 on the 805 is a RF stage alignment cap...)

RA/RD jumper (CN7).

Is for use when using the radio with the digital recording option. RA position is for audio that follows the squelched audio, RD position is for unsquelched audio, (noise and audio).

17-09-2000

(TK-760) Programming Kenwood TK-760 mobile

1. Press and hold "A" key while turning the power on. ("SEL" will be displayed)
2. Press "MON" ("CH 1" should be displayed.)
3. Press "SCAN" or "D/A" to select the channel to edit (1 - 32).
4. Press "CHANNEL DOWN" to view the receive frequency
5. If you see "-----" press "CHANNEL UP" and then use the following to set the required frequency. If you see a frequency and it is wrong, use the following to change it.
 - "VOLUME UP" and "VOLUME DOWN" keys set the megahertz of frequency. (---.000)
 - "SCAN" and "D/A" keys set the kilohertz of frequency. (154.---)
6. Press "CHANNEL DOWN" to advance.
7. Do you need a "Receive CTCSS tone"? If not, then press "CHANNEL DOWN"
If you need a tone, and you see "OFF", press "CHANNEL UP", then use "SCAN" or "D/A" to change it to what you want. If you see the wrong tone frequency just use "SCAN" or "D/A" to change it to what you want.
8. Press "CHANNEL DOWN" to advance to transmit frequency.
9. If you see "-----" press "CHANNEL UP" and then use the following to set the required frequency. If you see a frequency and it is wrong, use the following to change it.
 - "VOLUME UP" and "VOLUME DOWN" keys set the megahertz of frequency. (---.000)
 - "SCAN" and "D/A" keys set the kilohertz of frequency. (154.---)
10. Press "CHANNEL DOWN" to advance.
11. Do you need a "Transmit CTCSS tone"? If not, then press "CHANNEL DOWN"
If you need a tone, and you see "OFF", press "CHANNEL UP", then use "SCAN" or "D/A" to change it to what you want. If you see the wrong tone frequency just use "SCAN" or "D/A" to change it to what you want.
12. Press "CHANNEL DOWN" to advance.
13. Do this a couple of times to step through to the next channel. (Channel number will appear.)

IMPORTANT - When you are done, turn the radio off, wait a second, turn it back on. You are ready to use it.

May/00

This modification is read 1278 times.

[top of page](#)

16-04-2001

(TK-768) Programmin a TK-768 or TK-768H

Author: - nokia_trader@hetnet.nl.MODIFICATION.NET

- Press and hold "A" key while turning the power on.
"Prog" will be displayed shortly. And "Sel" will be displayed
- Press "MON" ("CH 1" should be displayed.)
- Press "SCAN" or "D/A" to select the channel to edit (1 - 32).
- Press "CHANNEL DOWN" to view the receive frequency
If you see "-----" press "CHANNEL UP" and then use the following to set the required frequency.
If you see a frequency and it is wrong, use the following to change it.
- "VOLUME UP" and "VOLUME DOWN" keys set the megahertz of frequency. (---.000)
"SCAN" and "D/A" keys set the kilohertz of frequency. (154.---)

- Press "CHANNEL DOWN" to advance.

Do you need a "Receive CTCSS tone"?

If not, then press "CHANNEL DOWN"

If you need a tone, and you see "OFF", press "CHANNEL UP", then use "SCAN" or "D/A" to change it to what you want. If you see the wrong tone frequency just use "SCAN" or "D/A" to change it to what you want.

- Press "CHANNEL DOWN" to advance to transmit frequency.

If you see "-----" press "CHANNEL UP" and then use the following to set the required frequency.
If you see a frequency and it is wrong, use the following to change it.

- "VOLUME UP" and "VOLUME DOWN" keys set the megahertz of frequency. (---.000) "SCAN" and "D/A" keys set the kilohertz of frequency. (154.---)
- Press "CHANNEL DOWN" to advance.

Do you need a "Transmit CTCSS tone"?

If not, then press "CHANNEL DOWN"

If you need a tone, and you see "OFF", press "CHANNEL UP", then use "SCAN" or "D/A" to change it to what you want. If you see the wrong tone frequency just use "SCAN" or "D/A" to change it to what you want.

- Press "CHANNEL DOWN" to advance.

Do this a couple of times to step through to the next channel. (Channel number will appear.)

VERY IMPORTANT - When you are done, turn the radio off, wait a second, turn it back on.

KENWOOD RADIO PROGRAMMER

Designed by: Nokia_Trader
Email: nokia_trader@hetnet.nl

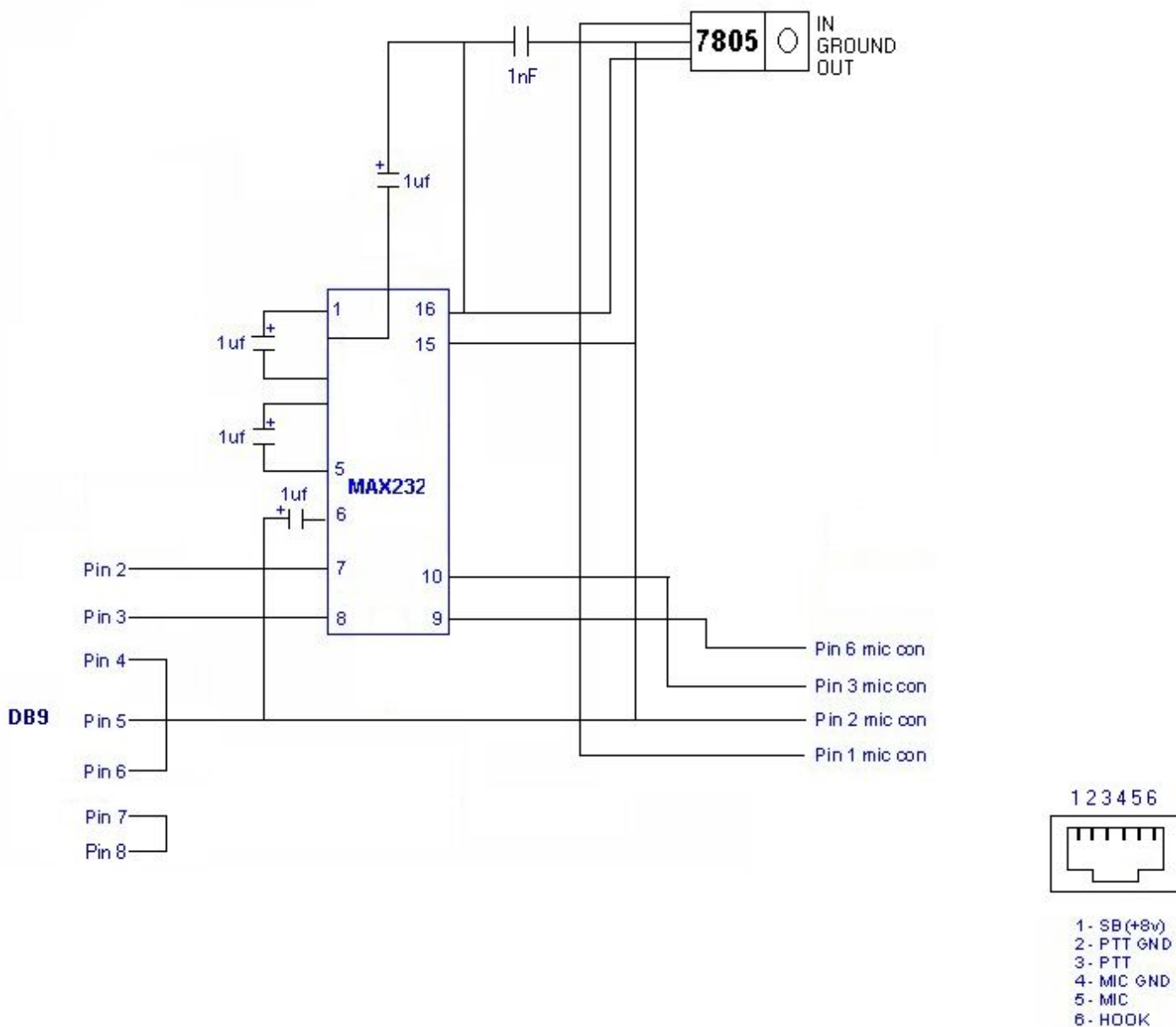

Model: TK-768 Series



08-07-2001**(TK-805) Kenwood TK-805D programming****Author:** Keith Beckmann - Kbeckmann@wi.rr.com.MODIFICATION.NET

Kenwood TK-805D Operation

Controls:

- **I/O** - On/Off Switch
-  - Monitor Mode (Squelch open)
- **AUX** - Auxiliary Mode
- **REC** -
- **SCAN** - Scan Mode
- **D/A** - Delete / Add
- **Volume** - Volume Control
-  - Selects Channel

Display:

- **CH x** - Channel x selected
- **TA x** - Channel x in Turn-Around mode (Simplex)
- **SCAN** - In active scan mode
- **SC x** - In scan mode, but stopped on channel x
- **AUX** - This channel has AUX (Simplex) mode enabled
- **ADD** - This channel is in scanning table

Kenwood TK-805D Setup

To enter setup mode:

1. Turn radio on while holding **AUX** and **SCAN**
2. Unit will beep 3 times.
3. Use **PTT** to save selection.



Function	Display	Selections
Band Range	450.000	150/250/350/450 MHz
Time Out Timer	t Off	Off, 30, 60, 90, 120, 180 Seconds
Busy Channel Lockout	b On	On - Enabled Off - Disabled
Del/Add Condition	dA On	On - User selectable Off - Fixed
Mic Hook Operation	H On	On - Scan on hook, PTT off hook, Monitor off Hook Off - Scan disabled, PTT on or Off Hook, No off Hook Monitor
Priority Channel	P Fl	Fl - Fixed Priority US - User Selectable
Monitor Switch	En On	On - Press to disable decode, hold to disable squelch Off - Press to disable squelch
Off-Hook Monitor	dE Off	On - No Off Hook Monitor Off - Monitor Off Hook *
Off-Hook Scan	SC On	On - Off Hook Scan Off - Scan On-Hook Only

* Off Hook Monitor (dE Off) is only enabled when On-Hook Scan (SC Off) is Selected.

When you reach **END**, you can power the radio off.

Kenwood TK-805D Channel Programming

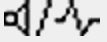
Note: While in the programming mode, switches have these functions:

-  - Hold to step forward and backward thru programming (Use  to move).
- **AUX** - Hold for 1MHz step rate.
- **REC** - Turns **AUX** indicator On/Off (Auxiliary mode enabled/disabled).
- **SCAN** - Toggles between 10 KHz and 12.5 KHz frequency steps.
- **D/A** - Turns **ADD** indicator On/Off (In/Out of scanning table).
-  - Change Selection

To enter programming mode:

1. Press turn radio on while holding **AUX** and **D/A**
2. Unit will beep 4 times.
3. Use **PTT** to save selection.

Function	Options
RX Frequency	390.000 to 490.000 MHz (Hold AUX for 1 MHz steps)
RX Tone type	Soff - No tone S dt - Digital PL S t - PL Tone
RX PL frequency	67.0 to 250.3 Hz (Digital: 000 - 777, SCAN inverts) (Hold REC for 10 Hz steps, Hold AUX for 1 Hz steps)
TX Frequency	390.000 to 490.000 MHz (Hold AUX for 1 MHz steps)
TX Tone type	Soff - No tone S dt - Digital PL S t - PL Tone
TX PL frequency	667.0 to 250.3 Hz (Digital: 000 - 777, SCAN inverts) (Hold REC for 10 Hz steps, Hold AUX for 1 Hz steps)

Repeat above steps for all channels. The channel number is shown in the lower right corner.

Note: A display of -.--- Indicates the channel is not programmed.

When channel 16 has been programmed, continue with settings below:

Kenwood TK-805D Channel Programming

Function	Display	Selections
Aux selection	tA	tA - Talk-Around (Simplex) DRS - Digital Recording System 2tonE - 2 Tone sequential decode dt - DTMF Decode
Scan Resume RX	rA 3.0	1.0 to 8.0 Seconds
Scan Resume TX	rb 3.0	1.0 to 8.0 Seconds
Fixed Priority Channel	P -	P - No priority Channel P xx - Channel xx is priority channel
Lookback A	La 1.0	1.0 to 8.0 Seconds
Loopback B	Lb 1.0	1.0 to 8.0 Seconds
Revert Channel*	CA cH	sT - Selected Channel (Last channel selected before SCAN pressed) P - Priority Channel CA - Last RX channel used US - Last TX channel used

* Revert channel is the channel the transmitter will switch to automatically, when PTT is pressed during off-hook scan.

When you reach **END**, you can power the radio off.

Note: The only way to clear a channel is to clear memory.

Clear Memory

Power radio on while holding **AUX + SCAN + D/A**

Date: 21-03-2002

User comment

From: [KC7GF](#)

Subject: 805/705 models

The programming listed for the TK805D also works for the TK705D. The 805 is UHF, the 705 is VHF but the programming steps are the same. Note that there is a earlier 705/805 model without the D. This model does not do DCS (digital coded squelch) and does not have scan and all the programming features of the D model. Some functions are set by switches on the board. All units will easily program into the ham bands. If you need more info on either one of these models, send me email at kc7gf@aol.com.

Date: 22-03-2002

User comment

From: [KC7GF](#)

Subject: Enableing program mode

In order to enable programming of the 705/805D radios, an internal jumper behind the display labeled SET/USER must be in the SET position. After programming, the jumper can be left in either position for use. Leaving it in the SET position lets the user put the radio in program mode without removing the case.

This modification is read 1291 times.

[top of page](#)

22-03-2002

(TK-805) Revised TK-705D & TK-805D programming

Author: [KC7GF](#) - kc7gf@aol.com. [MODIFICATION.NET](#)

Beginning with SN 41200000 several new programming features were included in these models. These new features include a programmable Monitor Switch function, OFF-HOOK Scanning, OFF-HOOK decode, Transmit Revert Channel (for off-hook scanning), and an additional Scan Resume Delay (for the transmit revert channel). This Service Bulletin is revised to include the programming procedure for these new features in the self-programming mode.

Entering the self programming mode is accomplished by turning on the power switch while pressing a combination of buttons which act as an interlock. Jumper CN-8 located on the main board behind the display is in the SET position when the radio is shipped from the factory. This enables self programming. If CN-8 is moved to the USE position, which is recommended prior to delivering the radio to the customer, the self programming mode cannot be entered. (The radio may be operated with the jumper in the set mode, but after exiting programming mode it will revert back to displaying channel numbers, not frequencies.)

Prior to initial programming, you may want to perform a Memory Clear. With CN8 in the set mode: **SIMULTANEOUSLY** press and hold the AUX, and SCAN and D/A while turning the power switch ON". This will remove any frequencies which were factory installed for testing purposes. The radio automatically enters the Option setting mode during memory clear.

To enter the Option Setting Mode without clearing memory, **SIMULTANEOUSLY** press and hold AUX and SCAN buttons while turning power ON (CN-8 on the main board must be in the set position).

OPTION SETTING MODE

(Pressing PTT between all functions stores the data and changes to next function)

Function	Display	Rotate channel selector to select	Press
1 Band range	150.000~	100Mhz SECTION (150-450)	PTT
2 Time out timer	t OFF	Off-30-60-90-120-180 Sec (default= off)	PTT
3 Busy ch lockout	b On	Off/on (default = on) no TX when channel is busy	PTT
4 DEL/ADD condition	dA On	On=user select, off=fixed see RX ch & DEL/ADD	PTT
5 Mic hook operation'	H On	On=scan on hook, PTT off hook, mon off hook, Off=no scan, ptt on or off hook, no off hook monitor	PTT
6 Priority channel	P FI	FI=FIXED US=user selectable (default=fixed)	PTT

Additional features from sn 41200000

7 Monitor switch	En On	On=press to disable decode, hold to disable Sq. Off=press to disable Squelch (default =on)	PTT
8 Off hook monitor	dE Off	On= no off hook monitor, off=monitor off hook	PTT
9 Off hook scan	sc Off	On= off hook scan, off=scan on hook only	PTT
10 END	END	(turn off power)	

RECOMMENDATIONS for NEW FEATURE SELECTIONS.

- Off Hook Monitor (dE OFF) is only enabled when On-Hook Scan is selected (SC=OFF)
- The "Last Called" option in the revert channel selection is supported in units bearing SN of 50700000 and higher only. Prior to this S/N, the "Last Called revert feature operated according to specifications outlined for certain export models only.
- The Revert channel during On-Hook scanning is the Priority channel only. The revert channel and Resume B selection is skipped during self programming when On Hook scanning is selected.

In the user mode, the display skips unprogrammed channels. During programming mode any mistakes in programming can be reprogrammed over but channels cannot be deleted once entered unless memory is cleared, and all desired information reprogrammed. When all desired tone and frequency entries are completed, continue pressing PTT (stepping across unprogrammed channels) until END is displayed. If any undesired channels were displayed prior to END, the memory must be cleared and reprogrammed. (memories may be cleared individually when using the KPG6D programming software by hitting all spaces.

FREQUENCY PROGRAMMING MODE

TK-705D AND TK-805D FREQUENCY, AUXILIARY & SCAN Programming

To enter the frequency programming mode, SIMULTANEOUSLY press and hold the "AUX and "D/A buttons while turning power "ON" (CN-8 on the main board must be in the SET position)

CH1 - RX FREQ

Set ch1 RX freq by turning channel selector, hold AUX key when turning to change 1mhz

Press SCAN to change channel step from 10 and 12.5kc UHF or 5 and 6.25kc VHF

Press D/A key to enable delete/add scan function for this channel

Press REC to enable AUX switch function on this channel (selected later) PTT

RX TONE TYPE

Use ch selector to set RX tone type, QT (tone) or DQT (digital) DQT only on D model PTT

RX TONE FREQ

Display reads St for tone or S dt for digital

Set receive tone or digital with ch selector=.1hz, Ch sel+AUX for 1's digit, REC for 10's digit on tone. For digital, ch selector = 1's, AUX +ch sel = 10's, REC+ch sel = 100's, SCAN=normal/ inverse (note that non-standard tones can be selected for both tone or digital) PTT

TX FREQUENCY

Note: when TX settings are being programmed the TX symbol (--^) will be displayed

Use ch selector to set TX freq (or press PTT to set no tx (RX only channel), Ch sel+ AUX= 1mhz

Use SCAN button to set step size (see above, same as RX) PTT

TX TONE TYPE

Set TX tone type (see above)

TX TONE FREQ

Set tone freq (see above) PTT

-----> Repeat the above for CH2 to CH16 (bypass any channel by pressing PTT on blank "----.----" channel.)

AFTER CHANNEL 16, PROGRAMMING ENTERS OPTION SELECT MENU (use Channel Sel to select option) AUX Set AUX button function,

DRS=digital recording (must have option board), 2tonE= two tone sequential decode, dt=DTMF, tA= talkaround. Only one AUX condition can be set for all channels, however it can be turned on or off for specific channels in operation mode. PTT

RESUME A TIME

Set resume scanning delay time after receiving call in .5 second steps, PTT

RESUME B TIME

Set delay before scanning resumes after transmitting (in off hook scan mode) .5 sec, PTT

FIXED PRI CH

If option setting for priority is set at FI, fixed priority, select ch number, if set at US (user selectable) this will be skipped during programming, PTT

LOOKBACK A TIME

This sets the time between samples when looking back at the priority channel PTT

LOOKBACK B TIME

This sets the time between samples when looking back at the priority channel when the priority channel is busy but the signal does not have the PL tone you have programmed into the priority channel. PTT

REVERT CH (only enabled during off hook scan)

Use ch sel to set the channel the transmitter will revert to when PTT is pressed during off hook scan.

St = last channel selected before the scan switch was pressed

P CH = priority channel

CA CH = last channel a call was received on

US CH = last channel used (that was transmitted on) before scan switch was pressed PTT/ END

In programming mode pressing the MON (SPKR symbol) button and turning the channel selector knob will take you back or forward in the menu selections in case you make a mistake or decide to make changes to previous settings while programming. In operation mode, to add/delete channels for scanning, press scan and add/delete button.

Adjustment pots on theTK705D/805D, facing front of radio, left to right back row.

VR4=max deviation set , VR3=Mic sensitivity set , VR7=dig waveform bal (set for squarest digital waveform as seen at output frequency on service monitor), VR6=PL tone level (500 to 750 ~), VR5=power out (set to 27W) right side of silver VCO box VR1=preset squelch level, VR2=ABTO (this is the level control when using the digital audio recording option board).

TC1= frequency (TCXO) adjustment (NOTE:THIS IS ONLY ON THE 705D, THE 805D FREQUENCY ADJUSTMENT IS LOCATED ON THE TCXO MODULE WHICH IS TO THE RIGHT OF THE SILVER VCO BOX TC1 on the 805 is a RF stage alignment cap...)

RA/RD jumper (CN7).

Is for use when using the radio with the digital recording option. RA position is for audio that follows the squelched audio, RD position is for unsquelched audio, (noise and audio).

This modification is read 45 times.

[top of page](#)

19-07-1998

(TM-201) TM-201/401 Increased TX Audio

Some users of the TM-201 or TM-401 have reported they would like a slight increase in the microphone gain. Since there is no internal microphone gain control on these radios, as simple modification to the supplied MC-48 microphone will accomplish the same results. Proceed as follows:

1. Unplug the microphone from the radio.
2. Remove the 3 Phillips head screws securing the rear of the microphone. (A number 2 tip is recommended.)
3. Remove the push-to-talk (PTT) switch bar, paying particular attention to how it is installed.
4. Gently remove the small printed circuit board by lifting straight up, and swing the board over to allow access to the component side of the board.
5. Remove resistor R10, a 560 ohm 1/4 watt resistor.
6. Adjust VR1 Counterclockwise (CCW) 60 degrees.
7. Carefully reassemble the microphone, paying particular attention to the routing of the various wires, placement of the circuit board, and the PTT bar.
8. Reconnect the microphone to the radio and verify correct operation. Modification is now complete.

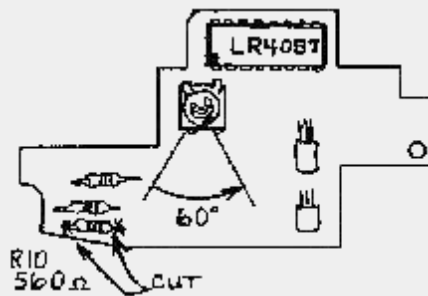

Time required for this modification is 1/2 hour or less.

This modification is read 424 times.

[top of page](#)

19-07-1998

(TM-211) TM-211 out of band modifications

The following is a simple modification for the TM-221 rig:

1. Locate the control unit board (X53-3040-XX) located behind the front panel.
2. Right below the channel select rotary switch and opposite the M.IN Sw. you will find R24 and R25. (foil side)
3. Remove R25 for 142.00 thru 151.995 Mhz RX TX
4. Move R25 to space for R24 for 138.00 thru 154.000 Mhz TX RX (Range will vary slightly from set to set)

Info provided by N2EYR @ WA2SNA-1 / Eddy Salvador

This modification is read 572 times.

[top of page](#)

19-07-1998

(TM-211) Extended range!

To get your 221A to receive from 138-174 MHz you need to remove the front panel and gain access to the chip resistors and rearrange them as follows:

R22	R23	R24	R25
X	O	O	X

X=Connected O=Left out

If you are running a vk version removal of R24 is all that is needed. The tx will remain at 144-148MHz even after the mod.
GEOFF VK3KGH @ VK3RPA

This modification is read 542 times.

[top of page](#)

19-07-1998

(TM-221) General Coverage XMIT - TM-221/A

1. Remove top and bottom covers, remove locking ring on mic connector.

Carefully remove plastic cover.

2. Pull front of radio off (plug in connector)
3. Locate the control unit (xx53-3040-xx)
4. Remove the small resistor chip from r25, this gives you xmit from
(142.000 thru 151.995)
5. Replace the same resistor chip from last step on to the same board at r24 which is empty, this gives you xmit from (138.000 thru 154.000) Each set will give different range depending on the vco setting, some will xmit higher than 154.000 and some will shut off lower. This can be changed by resetting the vco.

This modification is read 960 times.

[top of page](#)

19-07-1998

(TM-221) TM-221A Final Module Hints

Author: Trio-Kenwood Communication, inc.

Service Bulletin no. 934 (11-4-1988)

When the Final module is replaced in a TM-221A, there is a possibility that the transmit power will not go higher than 47 watts, even with the APC turned OFF. This is due to variances in input impedance of Final Modules.

To correct this condition, an 8 pF capacitor can be added between the input of the module and ground. With some modules, a value between 8 pF and 15 pF will be required. Try to choose a value as close to 8 pF as possible to prevent oscillation. The capacitor should be designated as C19 on the Final Unit (X45-1360-02).

Required Part

8pF Ceramic Capacitor Part # CC45CH1H080D

Alignment:

1. Turn the APC off (TX-RX unit VR-6: Clockwise).
2. Adjust TC3 TC4 (TX-RX) for maximum power supply current. Since the APC is off, the Final will produce very high power output. It is important to perform this step as quickly as possible.
3. Adjust the APC for 45 Watts.

This modification may be performed under warranty.
Time required for this modification is 0.25 hrs or less.

This modification is read 853 times.

[top of page](#)

19-07-1998

(TM-221) TM-221A No TX in High Power Due to Voltage Drop

Author: Trio-Kenwood Communication, inc.

Service Bulletin no. 933 (11-4-1988)

Some TM-221A transceivers may intermittently not transmit in the high power mode. This condition may be the result of a voltage drop at the fuse terminals on the power cord. To prevent a voltage drop, solder the terminals by following the procedure below.

1. Disconnect the antenna and power supply.
2. Open and remove the plastic fuse holder.
3. Remove the fuse from the terminals.
4. Flow solder between the terminals and the exposed strands of the cable. (See the figure below).

5. Allow the terminals to cool and then reinstall the fuse and close the holder.

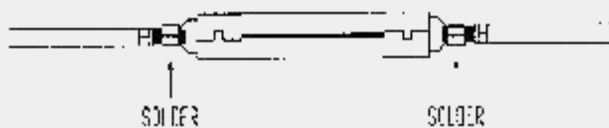

This modification may be covered under warranty.
Time required for this modification is 0.25 hrs or less.

This modification is read 777 times.

[top of page](#)

24-01-1999

(TM-221) Extended range

The get your 221A to recieve from 138-174 Mhz you need to remove the front panel and gain access to the chip resistors and re-arrange them as follows:

R22	R23	R24	R25	
X	O	O	X	X = Connected O = Left out

If you are running a vk version removal of R24 is all that is needed. The TX will remain at 144-148 Mhz even after the mod.

This modification is read 887 times.

[top of page](#)

19-07-1998

(TM-231) TM-231A MARS/CAP modification

1. Disconnect power
2. remove top cover
3. Locate a green jumper wire sticking out of the front panel assembly (behind VFO switch)
4. cut the jumper in half. Insulate the ends if bare wire is sticking out
5. Assemble radio
6. reset the microprocessor (hold mr key and turn on power)

this mod will allow the TM-231a to transmit from 142-151.995 MHz
N7LMJ @ KB7CFD.ID.U.S.A.N.A

This modification is read 868 times.

[top of page](#)

19-07-1998

(TM-231) TM-231A Out of band

05/20/90

This document describes the steps in enabling out of band transmit to the Kenwood 231A 2 meter transceiver. This modification will allow transmit throughout the 136.000 to 173.995 Mhz range. I do not condone, authorize or any way promote illegal out of band communication. More than likely, performing this modification will void the warranty, also no guarantees are made and you are at your own risk. In other words, don't blame me if you kill your radio! Please read all of text before deciding or continuing. Also performing either the MARS/CAP mod or the full extended transmit mod will erase the memories.

First of all you should be aware that this modification disables the automatic ARRL transmit offset feature. Second, if you do not feel comfortable taking your radio apart, soldering to a surface mount board, or working with very small items, please find someone who can help you.

Ok, now with all that out of the way, here we go. You will need: a VERY small soldering iron with a tip no larger than about a sixteenth of an inch, a phillips screwdriver, a pair of VERY small tweezers or forceps, some very thin solder, a 1N914, or similiar glass diode (NOTE: if you have a chip diode of similiar rating, all the better!), a small box to put all the tiny parts in. Also a small vise or circuit board holder and a pair of external snap ring pliers are helpful. At this time it would be a good idea to write down the memories on a piece of paper, as doing the mod erases the memories. Disconnect the microphone, power, and antenna.

MAKE SURE NO POWER IS CONNECTED TO THE RADIO!

1. Take the radio apart --- Remove the 4 black phillips head screws from the top and bottom black metal shields, put them in the small box so as not to lose them. Remove the two metal covers and put them aside.

Note:

If you just want to mod the radio for MARS/CAP, just remove the top cover and clip the GREEN wire just above the VFO,MR,MHZ switches, and replace the top cover. This extends transmit about 3 Mhz on either side of the ham band.

Place the radio on a pad or soft STATIC free work area. Looking at the front of the radio, you will see how the black face plate is held in place by 4 little plastic keepers that run over metal bumps in the sub-frame. By GENTLY inserting your finger nail and pushing each keeper, you will be able to remove the face plate, be careful, its plastic. Pull the volume, squelch and frequency selector knobs off, the freq. selector is a real bear, but a strong steady pull will remove it. Next, using a pair of pliers or a set of external snap ring pliers, remove the mic connector ring nut from the mic connector, now remove the nut that is on the freq. selector. Again put all the parts in the small box. Gently remove the LCD assembly from the radio. You will see a series of silver springs mounted horizontally on the back of the LCD assembly, these mate with short silver pins on the cpu board. Put the LCD assembly aside in a safe STATIC free place. The next step is to remove the metal shield that covers the cpu board. Do this by removing 4 screws, two are located on the short sides and the other two are located on the top and bottom of the radio. Put the screws in the small box for safe keeping. Gently remove the metal plate from the radio and put it aside. Finally the cpu board must be removed. If your radio has the CTCSS encoder and/or the DRU voice recorder, you must remove these before continuing. Consult the manual and reverse the installation procedures to remove them. Be careful when pulling the small white multi pin connectors, forceps work the best. There are 3 screws that hold the cpu board on to the radio frame. Two are located to the right of the frequency selector and the third is located near the squelch control. Also there are two multi pin connectors located at the bottom of the backside of the cpu board that connect to the rf portion of the radio. Remove the 3 screws making sure not to drop them on the board. (Remember the battery backup!) Now using your thumbs at the bottom, and your fore fingers at the top of the board, gently disconnect and remove the cpu board. Be careful in handling the board as it contains many static sensitive components. Always hold the board by the sides as to not touch any traces or pin leads. If you have a small vise or circuit board holder, place the board in it, solder side up, so the row of switches (Call, F, Shift, Tone, Rev, Drs) are pointing toward you.

What needs to be done, is to solder a diode to the pads located under the tone switch. (S205) This is D209 on the schematic. Note that Kenwood calls the radio with this diode installed a -21 version, for use in "other areas". You will probably notice how small and how thinly spaced the pads are, and you will be wondering how that BIG diode is going to fit!...

2. Making the mod --- If you have a chip diode that will fit, skip this part. Otherwise, like me, you will have to fabricate your own SMT diode. Do this by bending the leads of the diode under the body and clipping the remaining lead lengths so that space between the leads are equal to the spacing of pads on the board. THE DIODE MUST BE POSITIONED SO THAT THE CATHODE IS POINTING DOWN, TOWARD THE CPU CHIP. THIS IS VERY IMPORTANT.
Try making about 5 of these guys, taking each one and visually fitting it to the pads. Look at the overall height compared to the height of the connectors. Also look at the pad spacing, a magnifying glass works well unless you have eyes like a microscope. Once you've selected the best one, tin the leads of the diode so just a quick tap of the hot soldering iron will "plant" the part on the pads. Now, holding the diode in the proper orientation, tack down one lead, (hopefully you didn't drink too much coffee this morning!), then, using the tweezers orient the other lead and tack it down with the soldering iron. You shouldn't need any additional solder, just the solder on the pad and the tinning on the diode leads. Using the magnifying glass, FULLY INSPECT THE CONNECTION, making sure there are no solder bridges and that the diode is positioned properly with the cathode pointing toward the cpu. Once you are satisfied proceed with step 3.
3. Button it up --- Reverse the take down procedure to put the radio back together. Attach the cpu board by aligning the connectors on the back, press firmly to engage the connectors, insert the 3 screws and tighten, remember the radio frame is aluminum, so don't strip them out. Attach the metal sub frame using the 4 screws. Gently place the LCD sub assembly on top and hold it in place so the little springs make contact while you attach the microphone connector ring nut and the freq. selector nut. Tighten them down. Press the plastic face plate so that the little keepers "snap" over the bumps. Re-attach the CTCSS and/or DRU if applicable. Replace the top and bottom black covers with the four screws. Check the small box and make sure you don't have any "spare" parts.

That's it, just connect power, antenna and the microphone. Turning on the power will reset the radio erasing all memories. Oh well...

This modification is read 982 times.

[top of page](#)

19-07-1998

(TM-231) TM-231 Low Mic Audio Fix

A quick and dirty fix for the knwd tm231a low mic output till (if) knwd comes out with a fix is to bypass r 63 (3.3k). r 63 and r64 form a voltage divider at the input to the mic amp. r63 is on the bottom of the rig. with the bottom cover off and the front of the rig facing you, locate the mic amp board 3610 which stands vertically off the mother board. follow the 3rd pin from the left to r63. a jumper here gives the tx audio a nice boost. be sure to readjust the dtmf output in the mic (the only pot in the mic). 73 and good luck. greg.

This modification is read 780 times.

[top of page](#)

(TM-231) TM-231A Intermittent memory loss

Author: Trio-Kenwood Communication, inc.

Service Bulletin no. 966 (4-4-1990)

Some TM-231A owners have reported that the transceiver intermittently loses its memory channel information at power on. The following modification will absorb pulses on the CPU interrupt line (INT4) and reconfigure the backup switching circuit to avoid unintentional memory loss.

This modification should be performed on a Dealer level as they have the correct tools to disassemble the transceiver.

Required parts:

220 μ F, 6.3 V Electrolytic capacitor	CE04NW0J221M
0.01 μ F ceramic capacitor	CK45B1H103K
0.022 μ F ceramic capacitor	C91-0475-05
2.2 Kohm chip resistor	RK73FB2A222J
1 Kohm carbon resistor	RD14BB2C102J
3.0 V Zener diode	MTZ3.0JB

1. Disconnect the power supply, antenna, and microphone.
2. Remove the top and bottom covers (4 screws). You may want to disconnect the speaker and set it aside with the speaker mount.
3. Remove the knobs from the front panel.
4. Remove the nut from the microphone jack and the 11mm nut from the channel selector switch.
5. Remove the 4 screws that secure the front panel to the body of the transceiver.
6. Pull the front panel off the transceiver to expose the Control board.
7. Remove the 3 screws from the Control board. Gently pull the board off the transceiver.
8. Perform the changes shown in the accompany diagram. C202 is on the component side of the Control board. All other work will be done on the foil side of the board.

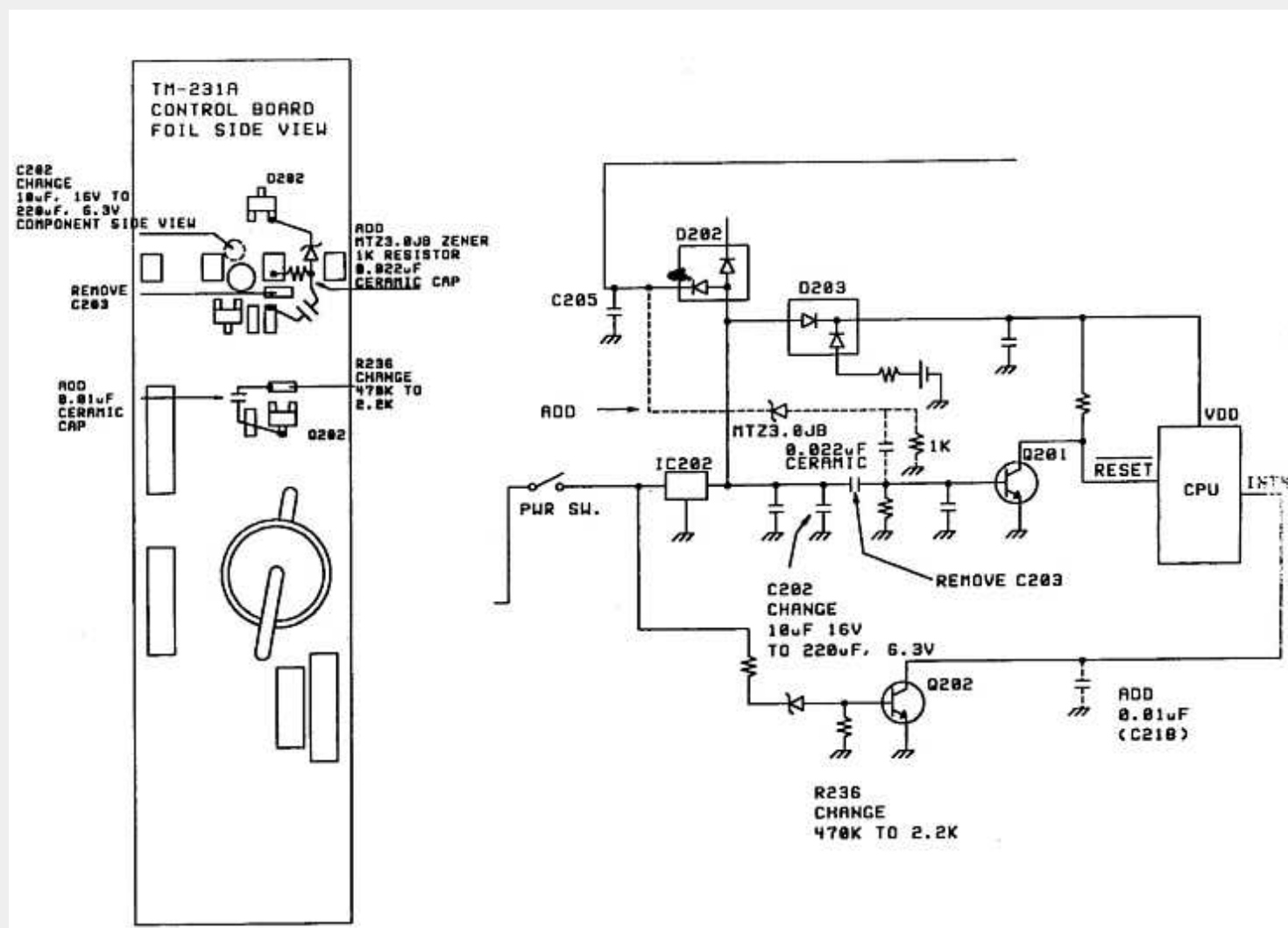

This modification may be covered under warranty.
Time required to perform the modification is 1 hour or less.

19-07-1998**(TM-241) TM-241A RX/TX mods**

This mod is only intended for experimental applications only! Know what freq you are on and don't use this mod if you are not for sure.

The TM-421a is capable of transmitting from 136 to 174 MHz when the following modification is performed. The transmitter specifications will vary from published in-band specifications.

1. Remove the top and bottom covers from the transceiver.
2. Remove the knobs from the front panel.
3. Remove the nut from the mic jack and the nut from the channel selector switch.
4. Remove the 4 screws that secure the front panel to the body of the transceiver.
5. Pull the front panel off the transceiver to expose the Control board.
6. Remove the 3 screws from the Control board. Gently pull the board off the transceiver.
7. Cut the GREEN jumper wire on the Control board.
8. Install an MA141A chip diode or 1N914 diode as D209 on the Control Board.
9. Reassemble the transceiver by reversing steps 1 - 6.
10. Reset the microprocessor by holding in the MR key as power is turned on.

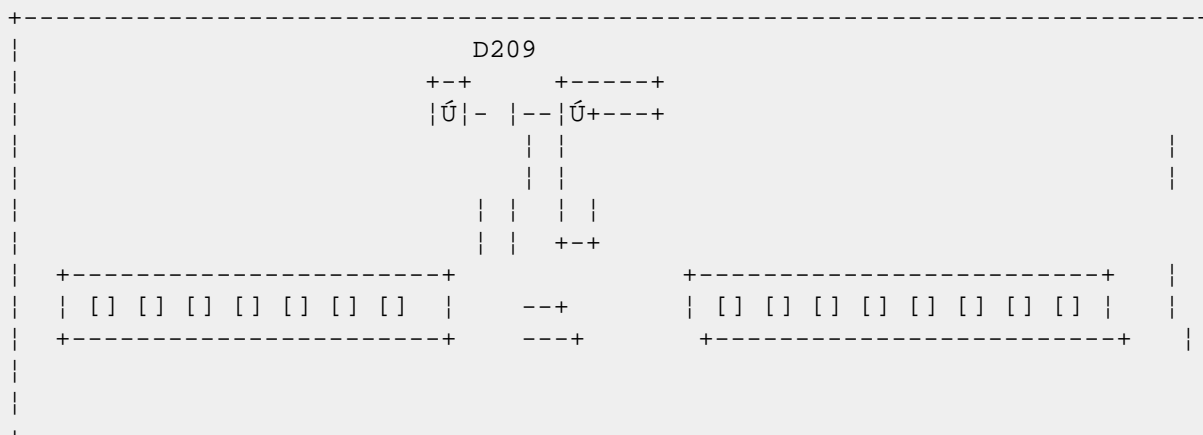
**Date:** 22-09-2001**User comment****From:** [Scott D](#)**Subject:** More info

Clip green wire on opposite side of board. W202 above the volume knob. In between the VFO and MR buttons.

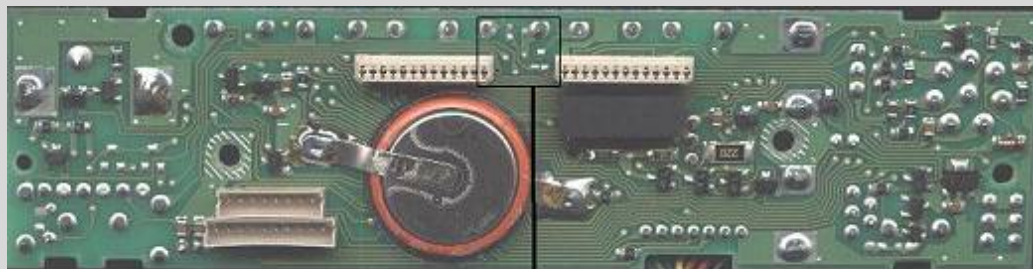

Clip Green wire on opposite side of board. W202 above the volume knob. In between the VFO and MR buttons

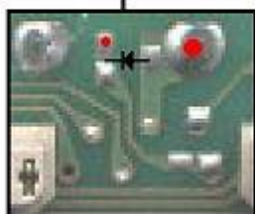

1N914, 1N4148, or MA141A glass diode or similar surface mount diode will work fine. If your using a glass diode it is easier to solder to the red dots. Be careful to get the cathode and anode oriented correctly or it will not work.

1N914, 1N4148, or MA141A glass diode or similar surface mount diode will work fine.

If you using a glass diode it is easier to solder to the red dots. Be careful to get the cathode and anode oriented correctly or it will not work.

17-07-1999**(TM-251) This is the wide-banding modification for the Kenwood TM-251E****Author:** Robert Veal. GM7AVE - robert.veal@fview.demon.co.uk.MODIFICATION.NET

This is an update to the original file sent out. Hopefully this one gets out un-corrupted. There are no changes to the mod listed so if you have previously modified the radio OK, then you do not need this file.

The Mod...

This is the wide-banding modification for the Kenwood TM-251E

This file is written by Robert GM7AVE, who performed this mod to a friends radio. Be careful if you decide to do this mod. Check if this mod is valid for your model before doing it. You may contact me at: robert.veal@fview.demon.co.uk.MODIFICATION.NET

The mod begins...

1. Remove both lids,
2. Remove facia, knobs and vfo nut,
3. Remove the screw between the volume and squelch pots,
4. Remove the LCD, carefully, the connectors are fragile,
5. Remove the cage, it is held on by 4 screws,
6. Remove the 2 screws holding the control unit in place,
7. If fitted now remove the memory expansion and CTCSS boards,
The memories will still be there when you are re-building.
8. Now read this carefully, VERY VERY GENTLY pull of the control unit, this has 2 small connectors holding it in place.
If you are not careful enough, this PCB will flick off into orbit, and possibly be damaged.
9. Here we are, getting the soldering iron ready...
10. Locate D417 on the PCB. It is the one at the edge of the board, very close the IC401 which is a MD6433388F (Opposite side to knobs.)
To confirm this diode is the correct one, check using a digital meter that one end is connected to pin 60 of the above chip. The other end should be connected to pin 65 of the same chip VIA a 100ohm resistor.
Remove this diode. Check to see if the wire links are attached. If they are (I don't expect them to be) then remove them. These are marked W1, W2, W3 on the PCB.
11. Go have a cup of coffee now, then come back and put the radio back together again.
12. Do a CPU reset by powering up with MR pressed (Bye memories!)
Note: Sometimes a CPU reset isn't required, so do not do this initially, only do a reset if the radio malfunctions in some way when powered up.
13. Oh look, the radio will now receive and transmit from 136MHz to 174MHz, and also receive from 300Mhz to 470MHz.
14. If you also look at the menu's avaiable you will see a new one.
15. End of mod. Did you succeed or kill the radio? Let me know ok?

Mail to Robert Veal on FORTH VIEW BBS (0131 660 6680)
E-Mail to robert.veal@fview.demon.co.uk
Mobile telephone - Voda 0468 176788
GM7AVE @ GB7EDN (MRSGB) Stingray Systems(1996)

19-07-1998**(TM-2530) TM-2530/2550/2570 MARS/CAP**

The TM-2500 series radios may be easily modified for use on MARS/CAP frequencies from 141-150.995 MHz.

Locate the control unit (X54-1860-XX) on the bottom of the radio. This is the same board that the TU-7, and or MU-1 are mounted on. Just to the left of IC3 you will find a row of diodes. Cut diodes D8, and D11. After the diodes have been cut you will have to "reset" the microprocessor.

Microprocessor Reset.

1. Press and hold the [PS] key.
2. Turn ON the power switch.
3. Release the [PS] key.

All of your programmed data such as memory channel data, DCL data, and Phone number data will be erased and you will have to reprogram them. If the radio is not reset, it will not recognize that you have cut the two diodes.

19-07-1998

(TM-255) Solution 9k6 TM255/455

Dear OM's

This is what I found a service technical report from Kenwood acc. TM255 and TM455 9600bps Date November 8, 1994

SUBJECT: Countermessure against modulation during packet 9600bps operation.

Phenomenon:

A trouble modulation malfunction during packet 9600bps operation was found in the manufacturing process even trough there in input in the DATA terminal.

Pay heed to this trouble in replacing the analog switch IC13.

Cause:

This trouble is caused by variation in the analog switch IC13.

Even if the 9600bps SW Tr. (Q20:DTA124EK) has been turned ON, the analog switch IC remains unstable.

Counter messure:

We decided to raise the analog switch IC13 voltage while the 9600bps SW TR. (Q20:DTA124EK) is in action by changing the chip resistor R117 in the TX-RX-unit of TM455A/E and of TM255A/E.....etc.

R117= 10K to be replaced with 3K3

So if you have problems with those two say to your dealer to ask for SERVICE TECHNICAL REPORT No. B510-94-081E page 1/2 and page 2/2

73's DE PAT KE6MIQ

06-08-1999

(TM-255) Mods for the Kenwood TM-255E

Adjust LOW power setting

The way to adjust low power is to regulate VR401. This trimmer can be found under the speaker (regulates power between 2 and 30 watts).

Adjust HI power setting

To regulate the power of the HI position is to adjust VR601. You can find this trimmer on the back left side (remove top and locate the alu cover).

Please be carefully when you dismount and locate the trimmer.

Adjust TX-Power/SWR ratio

At the same place you can find VR603 and that is the SWR protection control. Be carefull when adjusting this trimmer, because it protects your transceiver against bad SWR, but can be usefull when power drops to much on relative good SWR.

Adjust AGC

To adjust the AGC time constant of the transceiver locate VR402 that can be found on the left side at the center when removing the top.

Note:

Please be carefully with these adjustments! All modifications you make is totaly at your own risk.

If you have any other mods for this good transceiver then please contact me.

73's De Guy ON1DHT @ ON0BWP. #BTN.BEL.EU

QTH: Aalst, Belgium, JO20AW

E-mail: on1dht@skynet.be

Website: <http://users.skynet.be/on1dht>

19-07-1998

(TM-2550) TM-2530/2550/2570 MARS/CAP

The TM-2500 series radios may be easily modified for use on MARS/CAP frequencies from 141-150.995 MHz.

Locate the control unit (X54-1860-XX) on the bottom of the radio. This is the same board that the TU-7, and or MU-1 are mounted on. Just to the left of IC3 you will find a row of diodes. Cut diodes D8, and D11. After the diodes have been cut you will have to "reset" the microprocessor.

Microprocessor Reset.

1. Press and hold the [PS] key.
2. Turn ON the power switch.
3. Release the [PS] key.

All of your programmed data such as memory channel data, DCL data, and Phone number data will be erased and you will have to reprogram them. If the radio is not reset, it will not recognize that you have cut the two diodes.

This modification is read 631 times.

[top of page](#)

19-07-1998

(TM-2550) TM-2550 DCL Call Sign Data

Author: Trio-Kenwood Communication, inc.

Service Bulletin no. 904 (7-2-1986)

Some owners of the TM-2530/50/70 have reported a loss of the DCL system call sign data when the power switch is turned off. The call sign data actually remains in memory, but timing prevents its utilization in some radios. Adding a resistor will correct this problem.

If you receive a radio that exhibits this symptom add a 47K ohm resistor to IC3 to the Slave CPU on the control unit (X53-1440-XX) between pins 4 and 20. Cover the resistor leads with "spaghetti" type insulation. Adding the resistor to radios that do not have this symptom will not cause any problems, so you may wish to add the resistor if you receive a radio for service for some other problem.

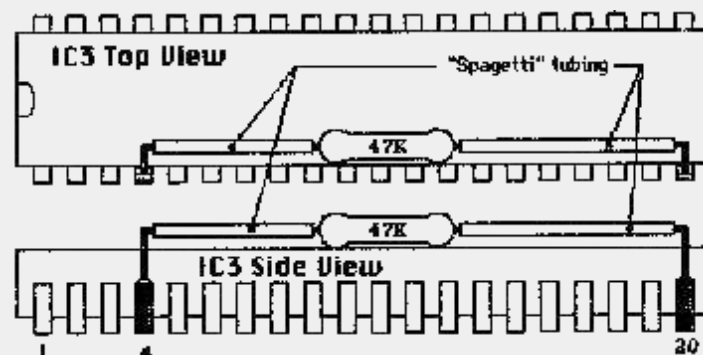

Solder the 47 Kohm resistor directly to pins 4 and 20 of IC13. Don't overheat or use too much solder. You must use an iron with vltage isolation on the tip!.

Before soldering unplug the DC power cable and antenna from the radio.

When soldering to this IC you must use a soldering iron that provides voltage isolation on the tip since IC3 is a CMOS device and can be easily damaged by static electricity or voltage on your iron. Use normal CMOS precautions. One final precaution: Don't bridge any of the pins on the IC with excess solder!

Time required for this modification is 1/2 hour or less.

This modification is read 604 times.

[top of page](#)

19-07-1998

(TM-2570) TM-2530/2550/2570 MARS/CAP

The TM-2500 series radios may be easily modified for use on MARS/CAP frequencies from 141-150.995 MHz.

Locate the control unit (X54-1860-XX) on the bottom of the radio. This is the same board that the TU-7, and or MU-1 are mounted on. Just to the left of IC3 you will find a row of diodes. Cut diodes D8, and D11. After the diodes have been cut you will have to "reset" the microprocessor.

Microprocessor Reset.

1. Press and hold the [PS] key.
2. Turn ON the power switch.
3. Release the [PS] key.

All of your programmed data such as memory channel data, DCL data, and Phone number data will be erased and you will have to reprogram them. If the radio is not reset, it will not recognize that you have cut the two diodes.

This modification is read 573 times.

[top of page](#)

19-07-1998

(TM-2570) TM-2570 Low TX Power Output

Author: Trio-Kenwood Communication, inc.

Service Bulletin no. 906 (18-3-1986)

Some owners of the TM-2570 have reported low transmitter power when the radio is used with an antenna having reasonably low VSWR (1.5:1)

Procedure:

1. Remove the bottom cover on the heat sink.
2. Ensure that C72 is installed correctly. (Refer to Service Manual)
3. Squeeze the coils of L16 closer together.
4. Make sure that C72 and L14 are as far away from each other as possible, move the capacitor, not the inductor.
5. Readjust VR1-VR4, according to the instructions provided in the Service Manual. The protection circuit, VR4, should be adjusted for 8A at 146.000 Mhz rather than the values indicated in the Service manual. Change your service manual to reflect this value.
6. Replace the bottom cover to complete the procedure.

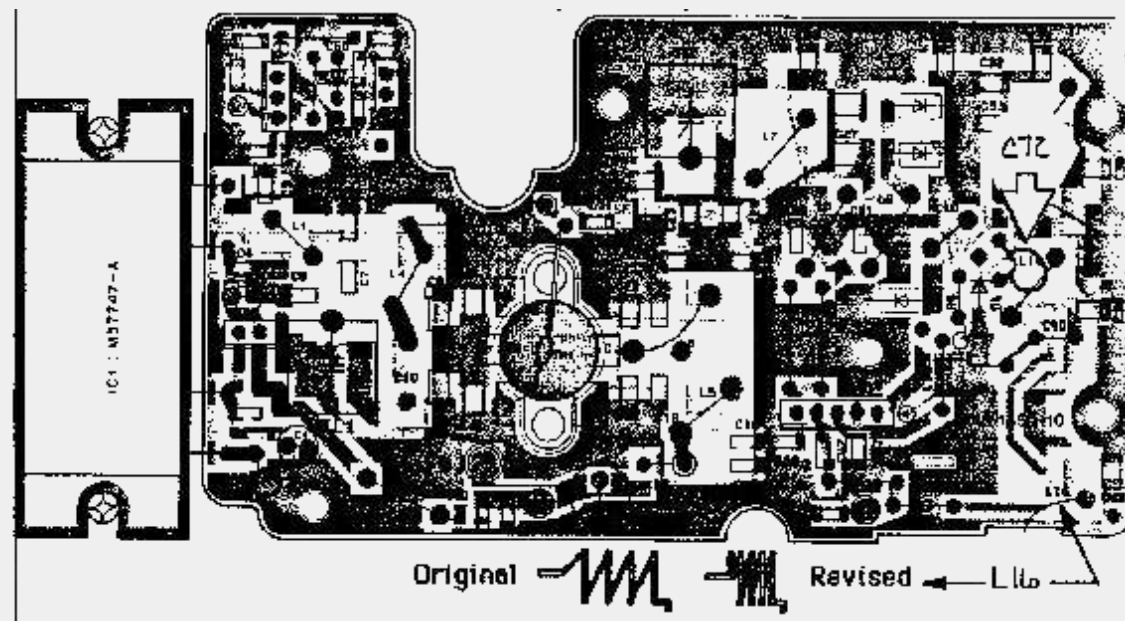

Time required for this modification is 1/2 hour or less.

This modification is read 568 times.

[top of page](#)

21-03-1999

(TM-261) TM-261a Extended frequency

If all u want is 142 to 152 cut green wire closest to the face of the radio.

If you want full covradge cut the one farthest from the face there both very close together and green.

This modification is read 1982 times.

[top of page](#)

28-08-1999

(TM-261) Kenwood TM-261a 136-174 MHz transmitt modification

Take off top cover cut two green wires only two there i think called w1 w2.
Transmitt from 136 to 174.

Date: 14-05-2000

User comment

From: Unknown

Subject:

Another guy has write this to me, for the same modification.

Open top case. There are two green wires. The closest to the face is W1. The other is W2. Cut W2 and that gives you transmit on 136-174.

I also tried just cutting W1 which gave me nothing.
Cutting both wires also gave me nohing.

Date: 27-08-2000

User comment

From: unknown

Subject:

The mods listed which require cutting two green wires did not work at first when performed.

I remember having to do more with the wire before the change occurred. I cut the two wires and held down one of the menu buttons while powering up the unit. However, the band did not open up. I then powered down the unit and stripped a short lead from each of the 2 cut ends of the two cut wires. I then turned on the radio and rubbed the two ends of one wire together for a moment and then did the same for the other cut wire while the unit was on. I then reset the radio and it opened the band.

When the the wires touched again while the unit was off, the unit reset and I had to open it up and play around with it again to open it up. (It seemed to set the radio back to it's original band settings.) Once the radio works out of band, make sure you do not connect the two wires even for a moment. The radio seems very sensitive. Hopefully this will help those who have problems.

(Do ! not cross the two green wires with each other. Only connect the cut ends of each wire with the other end of the original cut wire)

Date: 23-05-2001

User comment

From: [Russ WI9B](#)

Subject: Reset the VCO

Cut the green wire (W-1), then push "MR" and the "ON" buttons at the same time. When the screen lihts up with all the segments shown, push "MR" again. Basically you reset the VCO as shown on page 29 of the owners manual.

Russ WI9B

Date: 30-08-2001

User comment

From: [Bo Van Hassel \(W7RTK\)](#)

Subject: Complete mod

This is the correct mod for the tm 261a extended tx.. I complied this mod from the other mods on this page and have come up with the correct one.

- First, take top cover off radio.
- Next, locate the two green wires toward the face of the radio.
- Then, cut and tape the bare ends of W1. Do not let the wires touch each other again. W1 is the green wire above W2 (see illistration below)

Do not cut W2 as this will make the 136-174 TX mod not work!!!

- Reassemble radio and with the radio off, press and hold the "MR" button and turn the radio on.

As WI9B says, when the screen lights up with all of the segments shown, before the test segments go off, push "MR" again, and you will now tx from 136Mhz to 174Mhz.

73/DE/BO/W7RTK

```

+-----+
|               | ----- gold square in radio
+-----+
W1---  0-----0
W2---  0-----0
```

This modification is read 2172 times.

[top of page](#)

03-03-2002

(TM-261) TM-261 Mike Button

Author: Mike W8RY - w8ry@yahoo.com. MODIFICATION.NET

The Kenwood TM-261 2Mtr xcvr microphone displays an annoying feature: After you've had it for a while, the Mike Button must be pressed harder and harder in order to keep it transmitting. Eventually, the button is so intermittent that you want to strangle it with its own cord. The fix is simple.

Open up the Mike case (three screws) and carefully lift the back off, so small parts don't fall out onto the floor, such as the clear plastic piece, and the spring. Look at the mike button lever inside, and you will see that pressing the mike button causes a little red piece of rubber to press a microswitch, which actually keys the rig.

As this little piece of rubber gets old, it gets soft, and won't reliably press the microswitch, causing the transmitter to turn off frequently. This little piece of sponge rubber is a little bit smaller than a pencil eraser, so i removed it, and replaced it with a trimmed pencil eraser, which is not quite as thick as the original piece of ! sponge rubber. It has to be a bit thinner, so you don't apply too much pressure to the microswitch when you key the mike, causing the microswitch to bend or break off the PC board.

I used a dab of rubber cement to hold the eraser in place, and let it dry for a couple of hours before reassembling the microphone. Now it works fine, and my fingers aren't hurting from having to grip the mike button in a deathgrip to make it work!.

73 de Mike W8RY

This modification is read 297 times.

[top of page](#)

19-07-1998

(TM-321) TM-321A Mars/cap mod

To give the TM321 tx coverage from (142 Or 143, don't remember which) to 151.995 mhz, remove the top cover.

Look for a loop of wire coming from the display area (the board with the CPU) and going right back. Cutting this wire and then doing a CPU reset is all you need to do.

Takes about 2 minutes. Be sure that the ends of the wire don't short to something.

This modification is read 490 times.

[top of page](#)

19-07-1998

(TM-321) TM-321A Weak mic audio fix

A quick and dirty fix for the knwd tm231a low mic output: knwd comes out with a fix which is to bypass r 63 (3.3K). R 63 and r64 form a voltage divider at the input to the mic amp. R63 is on the bottom of the rig. With the bottom cover off and the front of the rig facing you, locate the mic amp board 3610 which stands vertically off the mother board. Follow the 3rd pin from the left to r63. A jumper here gives the tx audio a nice boost. Be sure to readjust the dtmf output in the mic (the only pot in the mic).

This modification is read 462 times.

[top of page](#)

19-07-1998

(TM-321) TM-321A Mod to Squelch thw audio at mic pin 6

The following is an easy mod to squelch the audio at mic pin 6 for tnc's

Without true dcd: obtain from kenwood a 2sd1757(k) (surface mount transistor). Install emitter to mic pin 8, collector to mic pin 6, and jumper from base to the unused pin on connector 202. Using the unused pin rather than running the jumper to the mother board preserves the plug in feature of the front panel.

Connect one end of a 4.7K resistor (i used a 6.8K) to the mute line (ic 5 pin 7), and connect the other end to the unused pin of connector 4, which mates with connector 202. This new circuit is a close copy of the af mute circuit that squelches the rx audio at the speaker. It works perfect with my paccomm micropower 2. The hardest part of the mod is removing the locking ring around the mic connector. I used a modified table fork! good luck.

This modification is read 453 times.

[top of page](#)

19-07-1998

(TM-321) Packet mod for TM-321

8 Nov 89

From: rfc@briar.philips.com (Robert Casey)

The following is an easy mod to squelch the audio at mic pin 6 for tnc's

Without true DCD: obtain from Kenwood a 2SD1757(K) (surface mount transistor). Install emitter to mic pin 8, collector to mic pin 6, and jumper from base to the unused pin on connector 202. Using the unused pin rather than running the jumper to the mother board preserves the plug in feature of the front panel.

Connect one end of a 4.7 K resistor (i used A 6.8 K) to the mute line (IC 5 pin 7), and connect the other end to the unused pin of connector 4, which mates with connector 202. This new circuit is a close copy of the af mute circuit that squelches the RX audio at the speaker. It works perfect with my paccomm micropower 2. The hardest part of the mod is removing the locking ring around the mic connector. I used a modified table fork! Good luck.

This modification is read 455 times.

[top of page](#)

16-04-2000

(TM-321) TM-321A Loss of TX audio with MC-48B

Author: Trio-Kenwood Communication, inc.

Service Bulletin no. 935 (2-6-1988)

When en MC-48B is used with the TM-321A, transmit audio may be suppressed do to RF feedback. This occurrence is restricted to mobile operation where the antenna is in close proximity to the microphone. The audio can be restored by adding a 100 pF capacitor directly to the mic element terminals.

Required parts:

100 pF, 50V capacitor. Part number CK45B1H101K or CC45B1H101K

1. Remove the 3 screws from the mic case (See figure 1). Carefully open the case.
2. Pull the PC board, PTT knob, and PTT micro switch out of the mic case to expose the mic element cover (See figure 2).
3. Remove the 3 screws and mounting clips (See figure 3) securing the element cover. Remove the PTT spring. Pull the mic element and cover out of the case.
4. Remove the element from the rubber cover.
5. Install and solder the capacitor directly to the mic element terminals where the brown and white wires are connected (See figure 4). To avoid damaging the element, use a low wattage soldering iron.
6. Carefully assemble the mic by reversing steps 1 - 4.



FIGURE 1

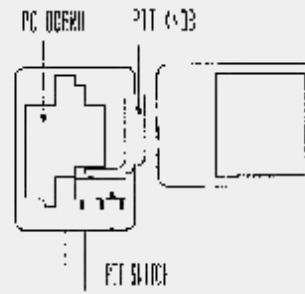

FIGURE 2

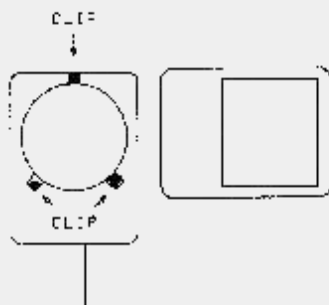

FIGURE 3

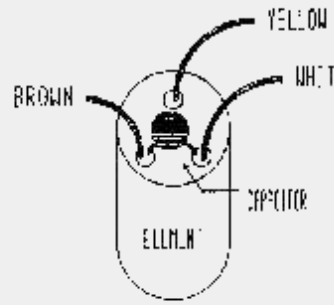

FIGURE 4

This modification may be covered under warranty.
Time required for this modification is ½ hour or less.

This modification is read 460 times.

[top of page](#)

16-04-2000

(TM-3530) TM-3530 Noisy transmit

Author: Trio-Kenwood Communication, inc.

Service Bulletin no. 925 (2-11-1987)

In some early model of TM-3530 transceiver transmit noise may be generated as the unit warms up. The following procedure will reduce the noise.

1. Disconnect the power cord and antenna.
2. Remove the top and bottom covers.
3. Replace L3 on the Compound unit (part number L15-0308-06). Before soldering the coil to the board, place a drop of contact or silicon glus under the coil to prevent mechanical vibration.
4. On the Compound unit, solder two springs (part number G02-0550-04) to the heat sink as shown in figure 1. The springs must be mounted high enough to make firm contact with the top cover when installed.
5. On the PLL unit, solder a spring (part number F10-1206-04) to the TX VCO shield (See figure 2). The spring must make firm contact with the bottom cover when installed.

Caution: The next step requires complete disassembly of the front panel and Display unit. This step may be reserved for problem units.

6. On the Display unit, replace jumper JP3 with a diode (part number 1S1555) as shown in figure 3.
7. Reassemble the transceiver and test the modulation for correct adjustment:
 1. Apply a 1 KHz, 50mV signal to pin 1 of the mic jack.
 2. Turn VR7 on the Compound unit fully CCW.
 3. Use a service monitor, linear detector, or deviation meter to measure the TX deviation at the antenna jack.
 4. Adjust VR5 on the Compound unit for +/- 4.5 KHz.
 5. Reduce the mic signal to 5 mV. Adjust VR7 for +/- 3.0 KHz.

Figure 1.

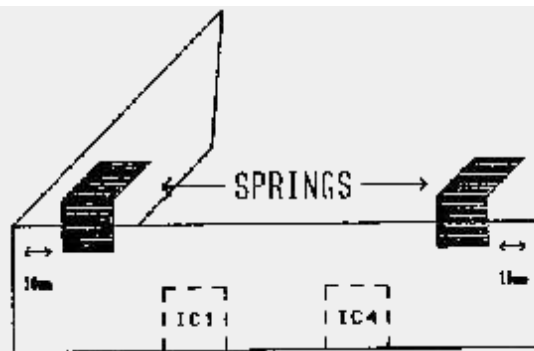

Figure 2.

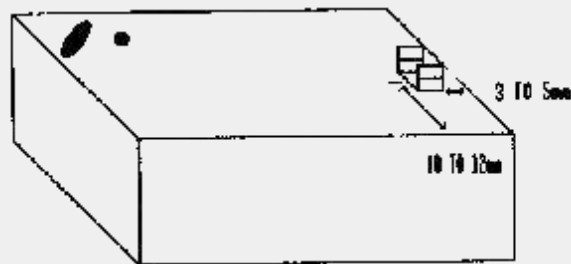
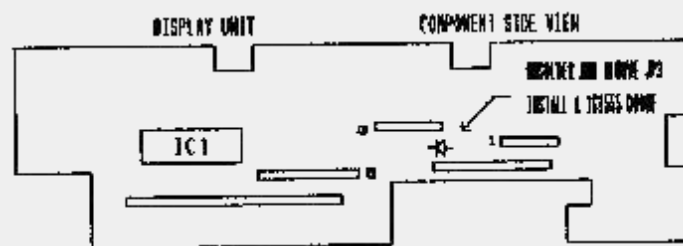

Figure 3.



Time required for this modification is 1 hour or less.

This modification is read 443 times.

[top of page](#)

01-09-2001

(TM-3530) Extended TX for the Kenwood TM 3530a 220MHz radio

Author: Bo (W7RTK) - nitehawk@ictransnet.com. MODIFICATION.NET

First, my radio's serial is 8,080,XXX so if your radio is close, it should work.

This radio is the big brother to the Kenwood TM 2530a except it xmits from 220Mhz to 225Mhz out of the box. I will show you how to make it tx from 220Mhz to 229.995Mhz...

1. With the radio upside down and the face facing you, remove bottom screws.
2. Remove the bottom panel and locate the control unit number X53-1440-XX
3. Locate the big chip marked above it as IC 3 (see illustration below)
4. Just to the left of IC3, you will see a row of diodes D9, D10, D11, D12 and D8. D9, D10 and D12 have already been removed from factory in my radio.
5. Cut diodes D8 and D11.
6. After cutting diodes, reassemble the radio, and then you must reset the microprocessor or the mod will not take effect.

Here are the steps,

1. With the radio off, press and hold the "PS" key.
2. Turn on radio.

3. Release the "PS" key.

Remember, when you reset the microprosser, you will lose ALL memory channels and phone numbers. So write everthing down first.

Your radio should now tx from 220Mhz to 229.995.



Have fun. 73/DE/BO/W7RTK

This modification is read 547 times.

[top of page](#)

19-07-1998

(TM-401) Umbau TM401A auf 9600bd und mehr

de DD4JN @ DB0IZ

Hallo liebe User,

um mit dem Kenwood TM401A in 9600bd in 9600bd QRV werden zu können, muß man erst den Filter "L7" mit der Bezeichnung CFW455F (12,5KHz) gegen einen breiteren, z.B. 20KHz oder besser, gleich auch für höhere Baudraten 30KHz, z.B. CFW455B einsetzen.

Um die RX-Daten abzugreifen, oder den keramischen Filter zu tauschen, muß man den oberen Deckel entfernen. Die RX-Daten müßen im Sternpunkt zwischen R31, R30, C33 und C40 abgegriffen werden.

Die TX-Daten werden, nachdem die Unterseite des TRX entfernt wurde, zwischen R91 und C93 eingespeist. Der Punkt befindet sich in der Nähe von Q54, dem IC NJM4558. Der Widerstand R91 steht senkrecht auf der Platine. Der obere Anschlussdraht ist lackiert. Farbe abkratzen und TXD-Leitung anlöten, fertig.

Bei Tx-Problemen muss man die richtige Filterstellung der G3RUH-Filter heraus suchen. Führt das auch zu keinem Erfolg, rät es sich, einen einfachen Umschalter 9K6 oder NF-Mike dazwischen zu schalten. Die Leitungen für den externen Umschalter habe ich durch das Weglassen einer Seitenwand nach außen geführt.

Die Leitungen vom Modem in den TRX habe ich durch Einbau einer anderen Remote-Buchse realisiert. Ich habe dafür die alte Remote-Buchse, sie ist nur geklammert, entfernt und von der Steckerleiste abgezogen. Dafür habe ich eine neue Buchse eingesetzt und mit den Leitungen TXD, RXD, PTT und Masse belegt.

Bei auftretenden Problemen oder Fragen stehe ich gerne zur Verfügung.

Viel Spaß beim Umbau wünscht Norbert, DD4JN

This modification is read 450 times.

[top of page](#)

19-07-1998

(TM-401) TM-201/401 Increased TX Audio

Author: Trio-Kenwood Communication, inc.

Service Bulletin no. 880 (25-10-1983)

Some users of the TM-201 or TM-401 have reported they would like a slight increase in the microphone gain. Since there is no internal microphone gain control on these radios, as simple mdification to the supplied MC-48 microphone will accomplish the same results. Proceed as follows:

1. Unplug the microphone from the radio.
2. Remove the 3 Phillips head screws securing the rear of the microphone. (A number 2 tip is recommended.)
3. Remove the push-to-talk (PTT) switch bar, paying particular attention to how it is installed.
4. Gently remove the small printed circuit board by lifting straight up, and swing the board over t allow access to the component side of the board.
5. Remove resistor R10, a 560 ohm 1/4 watt resistor.
6. Adjust VR1 Counterclockwise (CCW) 60 degrees.
7. Carefully reassemble the microphone, paying particular attention to the routing of the various wires, placement of the cirucit board, and the PTT bar.
8. Reconnect the microphone to the radio and verify correct operation. Modification is now complete.

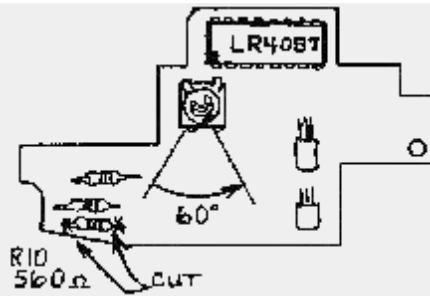

Time required for this modification is 1/2 hour or less.

This modification is read 465 times.

[top of page](#)

19-07-1998

(TM-411) TM-411 Low/No Receiver Sensitivity

2-14-85

Some users of the TM-411 have reported a loss of receiver sensitivity.

This may occasionally be traced to a loss of oscillation in the 2nd Oscillator, L29, on Unit A. Changing the below listed parts should correct any loss of sensitivity due to problems in the 2nd Oscillator.

O A Unit (X44-1600-00) change the following parts:

XTAL L29 to L77-0873-05

C15 to a 1.5 pf cap.

C54 to a 33 pf cap.

Time required for this modification is 1/2 hour or less.

This modification is read 487 times.

[top of page](#)

23-04-2000

(TM-411) TM-411A Microprocessor change

Author: Kenwood Communication, inc.

Service Bulletin no. 1041 (10 February 1994)

Symptom:

Due to a recent rule change by the FCC it is no longer possible to supply transceivers, or provide replacement microprocessor that would allow a transceiver to receive in the 800 MHz band.

Corrective action:

The microprocessor program of IC5 has been modified to prevent 800 MHz band reception. Production has been changed beginning with serial number lot 510xxxx. Units produced after this point will not be capable of 800 MHz reception.

Parts required:

Qty	Description	Old part No.	New Part No
1	Microprocessor	75116GF-E83-3BE	75116GF-J19-3BE

Procedure:

When ordering a replacement microprocessor you will be supplied with the new version. Please make sure your customer understands the limitations of this new

This modification is read 494 times.

[top of page](#)

19-07-1998

(TM-421) TM-421ES fuer 9600 Baud

de DL8XAW @ DL8XAW.HH.DEU.EU

Moin alle zusammen...

Ich möchte an dieser Stelle mal über die Möglichkeit berichten, mit dem Kenwood TM421es 9600 Baud zu fahren. Der "Umbau" (wenn's denn wirklich einer ist) ist kinderleicht. Beansprucht vielleicht 15 Minuten incl. nachsehen im Schaltplan. Aber nun an's eingemachte...

Fangen wir mit dem Einfachsten an: Die RX-NF...

Sie kann DIREKT an der MIKE-Buchse abgenommen werden (PIN 6) und steht sofort zur Verfügung.

Und nun zur SENDE-NF...

Man sehe in die Schaltung, suche VR3 (in der Schaltung links unten ist ein gestrichelter Kasten: MIC (X59-3160-00)). Am Schleifer von VR3 ist man schon fast richtig. Man verfolge nun die Leitung weiter in Richtung "C9". Die Leitung geht also an PIN 3 des MIC-Moduls und kommt auf PIN 2 wieder raus.

Und genau der Pin wird angezapft und die TX-NF dort eingebracht.

Das Modul steht hochkant im TRX und hat 11 Pins. PIN 1 + 11 liegen auf Masse.

Wenn der TRX auf dem Rücken liegt (mit dem Display zum Körper) ist das dann der 2te PIN von rechts...

Nun muß nur noch ein R 56k und ein C 100nF in Reihe in die TX-NF, und schon gehts...

TX-Modem -> 100 nF -> 56K -> PIN 2 vom Modul.

Für die Leitung sollte man was abgeschirmtes nehmen. Ich habe hier Koaxkabel entsprechender "dünne" verwendet, und es geht wie wild (allen Unkenrufen zum trotz).

Leider sieht's mit der Durchführung des Kabels nach aussen etwas mies aus (der TRX iss ja auch sehr klein). Aber man kann den Deckel aufbiegen oder anbohren und sich so einen Ausgang schaffen. Der Phantasie sind keine Grenzen gesetzt....hi.

Ich hoffe, dem Einen oder Anderen geholfen, zumindest die Angst genommen zu haben. Der TM421es geht wirklich hervorragend für 9k6.

...das Modem hier ist ein TNC2H...und spielt UFB.

73, Jörg, DL8XAW @ DBOHBS+++

=====

from dj9km @ db0gv.#hes.deu.eu

Modifikation des Kenwood TM-421E für 9600 Baud Betrieb.

Diese Modifikation ist bei vielen Kenwood Geraeten der Serie TM-XXX - auch Duobandgeraeten - moeglich und ausprobiert worden. Bauteile haben natuerlich eine andere Bezeichnung und Lage im Geraet.

Das TM-421E - und natuerlich auch andere so modifizierte Kenwoodgeraete - sind nach dem aufstecken des Mikrofons auch weiterhin fuer FM-Fonie Betrieb geeignet.

Am Empfangsteil des FM-Transceivers ist keine Modifikation der Schaltung noetig. Das RX-Signal liegt am 8-pol Mikrofonstecker an Pin 6 mit einem Pegel von 150 mV / 600 Ohm an. Dieses Signal fuehre ich direkt zu meinem TNC2H. Bei vielen Geraeten der Kenwood TM-Reihe ist dieses Signal direkt vom Diskriminator auf den Pin 6 des Mikroeingangs herausgefuehrt.

Um mechanische Arbeiten zu verhindern und den Originalzustand des Geraetes weitestgehend zu erhalten habe ich das TX-Signal ueber eine "stillgelegte" UP- bzw. DOWN-Tastenleitung in das TM-421E gefuehrt. Dazu bietet sich der Pin 3(=DOWN) oder Pin 4(=UP) an.

Dazu die 12 Schrauben des Ober- und Unterdeckels entfernen. 3 Knoepfe abziehen. Die schwarze Fronteinheit nach vorne abziehen. Diese Fronteinheit wird nur durch zwei Nuten an der Unter- und Oberseite gehalten. Die Schalter "LOW" und "POWER" um 90 Grad vom Schalterkoerper abschieben. Plastikscheiben von "VOL" und "SQL" Achsen entfernen. Ueberwurfmutter und Distanzscheibe vom 8-pol Mikroeingang entfernen. Den Blechrahmen durch loesen der beiden Schrauben rechts und links vorsichtig nach vorne abziehen. Die nun freiliegende Prozessorplatine durch loesen der drei Kreuzschlitzschrauben loesen und komplette Platine von der Steckverbindung zur Geraetebasis abziehen. Die Leiterbahn zum Mikro Pin 4(=UP) direkt an dem Mikrosteckereingang auftrennen. Ein duennes Koaxialkabel (am besten geeignet 2 mm Teflonkabel) mit Innenleiter an Pin 4 und und Mantel an die Blechdurchfuehrung des "SQL" Potis anloeten und mit einen Stueck Klebeband gegen Kurzschluß nach hinten absichern. Das Koaxkabel durch den Ausbruch neben der Buchsenleiste nach oben zur Bestueckungsseite herausfuehren.

In Umgekehrter Reihenfolge Frontteileinheit wieder zusammenbauen.

Das TX-Signal wird wie folgt zur MIC-Platine (TM-421E = X59-3160-00) gefuehrt :

_____ (koaxkabel-)

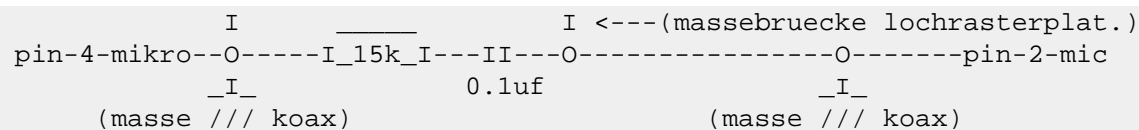

Den 15 KOhm Widerstand und den 0.1uf Kondensator fixiert man auf einem Stueck Lochrasterplatine und schraubt die Platine in der Mitte der Bestueckungsseite an einem angedeuteten Loch am Alu-Spritzgußrahmen mit einer Blechtreibschraube fest.

Von der Lochrasterplatine fuehrt man das TX-Signal wieder ueber ein duennes Koaxkabel zur MIC-Subplatine. Die Platine befindet sich beim TM-421E auf der Bestueckungsseite stehend zwischen den Reglern VR3 und VR4/VR7. Im TM-421E ist sie auf der Rueckseite mit 3160-00 bezeichnet.

Eingespeist wird das Signal an pin 2 auf der Loetseite der Basisplatine.

Pin 1 der stehenden Subplatine ist auf der Bestueckungsseite mit einem (gruenen) Punkt gekennzeichnet. Einen geeigneten Masseanschluß fuer das Koaxkabel sucht man sich in der Naehe der MIC-Subplatine auf der Loetseite der Basisplatine des Geraetes mit einem Ohmmeter. Koaxkabelanschluss auf der Unterseite ebenfalls mit einem Stueck Klebeband gegen den Deckel absichern.

Abgleich :

Der NF-Abgleich muss sehr sorgfaeltig erfolgen, da durch die umgangenen Begrenzerstufen die Varicap (TM-421E = D2) im VCO schnell ueberfahren wird und es sodann zu sehr breitem Signal und anderen "Schmutzeffekten" kommt. Ich bin folgendermaßen vorgegangen : Mit einem Scope habe ich mir den Hub des 1750 Hz Ruftones an pin 2 der MIC-Subplatine angesehen und dann in meinem TNC2H mit dem Regler P1 (Mod-Vol) den gleichen NF-Pegel eingestellt.

Unbedingt notwendig ist die genaue Einstellung der Ausgangsfrequenz mit einem zuverlaessigen Frquenzaehler. Bei meinem TM-421E lag sie inzwischen um ca. 1.6 khz daneben, was bei FM-Foniebetrieb ziemlich unerheblich ist, aber bei Packet-Betrieb bedingt durch die 9600 Baud Bandbreite zu Problemen fuehrt. Beim TM-421E ist das mit dem Trimmer TC3 moeglich.

Als Filterstellung im TNC2H benutze ich :

- Dip-switch 5 unten
- Dip-switch 6 oben
- Dip-switch 7 unten
- Dip-switch 8 oben

Diese Einstellung ist fuer die meisten Kenwoodgeraete der Serie TM-XXX zu ge- brauchen.

Damit ist der Abgleich beendet. Absolut optimal ist der 9600 Baud Betrieb mit einem PLL Geraet, welches fuer FM-Fonie konzipiert wurde, natuerlich nicht.

Ein Datendurchsatzvergleich, durchgefuehrt an DB0SPC mit einem Testfile von 5000 Byte, zeigt fuer einen speziellen 9600 Baud Transceiver eine Uebertragungszeit auf der Strecke von ca. 10-15 Sekunden an. Das umgebaute TM-421E kommt dabei auf ca. 20-25 Sekunden.

So dann viel Spass und Erfolg beim Umbau und natuerlich am 9600 Baud Betrieb ...

de Klaus - dj9km @ db0gv.#hes.deu.eu

This modification is read 570 times.

[top of page](#)

19-07-1998

(TM-421) TM-421a TX mod

This mod is only intended for experimental applications only! Know what freq you are on and don't use this mod if you are not for sure.

The TM-421a is capable of transmitting from 136 to 174 MHz when the following modification is performed. The transmitter specifications will vary from published in-band specifications.

1. Remove the top and bottom covers from the transciever.
2. Remove the knobs from the front panel.
3. Remove the nut from the mic jack and the nut from the channel selector switch.
4. Remove the 4 screws that secure the front panel to the body of the transceiver
5. Pull the front panel off the transceiver to expose the Control board.
6. Remove the 3 screws from the Control board. Gently pull the board off the transceiver.
7. Cut the GREEN jumper wire on the Control board.
8. Install an MA141A chip diode or 1N914 diode as D209 on the Control Board.
9. Reassemble the transceiver by reversing steps 1 - 6.
10. Reset the microprocessor by holding in the MR key as power is turned on.

This modification is read 645 times.

[top of page](#)

19-07-1998

(TM-431) TM-431A Wide Band Transmit Modification

This modification allows the TM-431A transceiver to transmit and receive from 420.000 MHz through 444.975 MHz with essentially full power throughout the band.

1. Disconnect power
2. Remove top cover
3. Locate a green jumper wire sticking out of the front panel assembly (behind VFO switch)
4. Cut the jumper in half and insulate the ends
5. Assemble radio
6. This will reset the microprocessor and you will have to reprogram all channels

This modification is read 562 times.

[top of page](#)

19-07-1998

(TM-431) 9600 mod for TM431A

Connect TX data to MO input at PLL circuit board (X58-3480-00) through a 100 kohm resistor.
Connect RX data to DET output pin 12 at IC1 (FM IF HIC)

The only problem is that you must mute the TX data when you RX, because this way you modulate the PLL.

You can find these pins when you open the bottom cover.
Locate the four points where the PLL circuit cover is soldered to.
They are marked with 0 in the drawing.

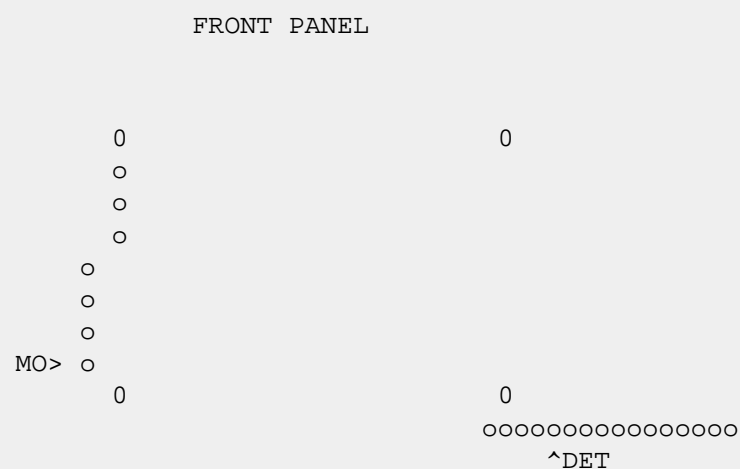

73 de Wes OH3NWQ @ OH3RBR. #TRE.FIN.EU
PS. I have tried this - it works.

This modification is read 500 times.

[top of page](#)

19-07-1998

(TM-431) TM-431E fuer 9600 Baud

de DL1YCL @ DB0SGL

Hallo OM's!

benutze seit langem meinen TM431E fuer 9600 Baud. Habe dazu PIN MO der PLL mit der zuvor mit einem Messer getrennten Lautsprecherbuchse verbunden.

im schaltbild steht:

X58-3480-00

PLL

darunter das ic der anschluss rechts oben heisst MO Speise nun also die 9600 Baud-AFSK ueber die Lautsprecherbuchse ein.

Das Demodulatorsignal liegt an der Mikrofonbuchse (PIN 6) und kann sofort verwendet werden.

Der TM431E ist ein geradezu ideales Geraet fuer 9k6.

Es kann sein, dass der Kondensator von MO (C 55 = .001) nach Masse (SMD-Technik) ausgelotet werden muss, um den Frequenzgang der 9k6 AFSK nicht zu beeinflussen. Ich habs gemacht.

Wuerde vorher aber mal probieren, ob man auf das Ausloeten auch verzichten kann.

1200 Baud speise ich ueber die Mikrofonbuchse ein. Das Demodulatorsignal an Pin 6 verwende ich fuer meine beiden Modems, 9k6 und 1k2.

Viel Spass

dies ist eine information von Christian in Hohenaspe, DK1QG JO43SX @ DBOHES ich markus aus datteln dl1ycl@db0sgl habe diese aenderung noch nicht durchgefuehrt und gebe diese information ohne gewaehr weiter.
da ich so viele anfragen wegen des umbaus des tm431 bekommen habe spiele ich die info in die kenwood-rubrik ein.
also alles ohne gewaehr und mit doppelten boden hihi.
ihr koennt mir ja mal eine kurze info zukommen kassen ob der umbau geklappt hat da ich ihn selbst erst noch durchfuehren muss(warte noch auf mein tnc2h) so das wars von mir

73 markus

This modification is read 488 times.

[top of page](#)

19-07-1998

(TM-431) Measure deviation using TM231,431,531

From AA9HX - ON7WP @ ON7RC.BT.BEL.EU

To all technical kenwood freaks,
All people clever enough to know that they have to do something about the tremendous amount of people constantly overdeviating, mainly all using off the shelf kenwood equipment, coming straight from the factory adjusted at 6,7 or EVEN 8 KHz Peak deviation !!!!

This article describes how YOU can use your kenwood transceiver TM231, TM431, TM531 and apparently also the TMX41 range to measure ON THE AIR deviation of repeaters and all other stations...

The principle of measurement is indeed very simple and DOES NOT NEED ANY MOD INSIDE YOUR TRANSCEIVER NOR EVEN OPENING IT !!!

Your microphone connector provides at pin 6 an audio output, straight from the FM detector. As all kenwoods use the same detector chip and coil, all give the same output voltage for a given deviation. The output at this pin 6 (and pin 8 as a ground) is linear up to 5 KHz deviation. As the IARU standard for amateur radio communication is 3 kHz peak deviation, this range from 0-5 KHz is perfect. Connect your oscilloscope to pin 6 and 8 as ground, 400 mV peak to peak voltage corresponds to 3 kHz deviation. So 200 mV is 1,5 KHz deviation and so on.

CTCSS deviation should be around 300 Hz although most kenwood transceivers only react well from 400 Hz.

Packet should be set to approximately 2 KHz.

And additional an extra tip for improving the modulation quality of your kenwood TMx31:

As the microphone amplifier is quite overdriven, modulation sounds very rough, due to extreme clipping of the signal, especially a nuisance in noisy environments, such as when mobiling in a not so luxury car.

This can become much better just by changing or in some cases adding the input resistor of the microphone amplifier. Different types are used depending on the market the transceiver was designed for. As they still believe at kenwood that europe uses a 25 kHz raster and the states 20 kHz, europe types get lesser attenuation before the amplifier than stateside trx's.

Hey You there at the kenwood factory reading this: whole europe is changing to a 12,5 kHz raster, so will you please stop delivering your transceivers and portabels with a deviation standard dating from jurassic park time !!!

schematic info:

Deviation potmeter TM231 VR3 and decrease R64

Deviation potmeter TM431 VR2 and decrease R58

Deviation potmeter TM531 VR3 and decrease R60

So remember 3 kHz is the standard, do not discuss whether it is good or not, IT IS THE STANDARD FOR AMATEUR RADIO.

It is the only way to live peacefully and to prevent wars between adjacent repeater or simplex channels.

(and by the way, narrowing the receiver bandwidth extends your range...)

Im looking forward to all comments, and I hope that somebody of the kenwood technical crew also will read this and do something about the adjustment of the new transceivers...

73 from Pedro M.J. WYNS AA9HX, ON4AWQ, ON7WP,
full licensed transceiver doctor... HI !
ON7WP @ ON7RC.BT.BEL.EU

This modification is read 508 times.

[top of page](#)

19-07-1998

(TM-441) TM-441E Umbau 9k6

de DC2FG @ DB0GV.HES.DEU.EU

Vorneweg: Der Umbau ist recht einfach.

Die Sende/Empfangsumschaltung kann man nach wie vor an der Mikebuchse abnehmen..ist klar (Pin 2).

RX KANN man auch dort abnehmen (Pin 6), der Pegel ist etwas kleiner als im Geraet (kommt halt aufs Modem an, was man da braucht); ich hab eins von dk9sj, da gehts hier wunderbar.

Ansonsten nimmt man Rx im Geraet ab wie folgt:

Unteren Gehaeusedeckel abschrauben, Geraet so legen, dass Frontplatte von einem weg zeigt (wir blicken nun auf die Loetseite der Platine).

Die Mikebuchse sollte sich nun oben rechts befinden; zwischen Frontteil des Geraetes und Platine sieht man nun 2 jeweils 13-Polige Anschuesse - nur der rechte interessiert uns:

Obere Reihe, der 3. Anschluss von rechts (RD heisst er), da ist die RX, die wir wollen. Der ganz rechte Punkt ist Masse (fuer die Abschirmung).

Man sieht, an der Mikebuchse ists einfacher....

TX:

Geraet so liegen lassen wie bisher.

Vom rechten Geraeterand aus ca. 9 cm und von den Kuehlrippen aus 3,5 cm; das ist der Bereich in dem wir wirken wollen !

Dort nun verlauft senkrecht nach oben eine Anschlussleiste der Unit 3480.

Der unterste Pin (Nr.1) ist TX, dort wollen wir einspeisen !

Schraeg rechts unter Pin 1 (auf ca. 5 Uhr) ist ein dicker Loetpunkt fuer die Masse.

Von dem Pin 1, an dem wir einspeisen, gehts uebrigens via C53 zum Hubpoti VR 2; das noch als Anhaltspunkt. Sehen tut man das Poti auf der Bestueckungsseite, es ist auf der Platine mit VR 2 beschriftet.

Tja, das war es schon.

Wie man nun wo die abgeschirmten Kabel verlegt, moege jeder nach eigener Kreativitaet entscheiden.

Viel Spass beim basteln !

Mein besonderer Dank geht hier an DC3KM und DJ0MDJ, die mir wertvolle Hilfen gaben.

Falls eine aehnliche Anleitung schon mal in den Boxen stand, sei auch diesem "Ureinspieler" gedankt, leider ist sein Beitrag dann in den mir erreichbaren Mailboxen der Lifetime zum Opfer gefallen.

73, Alex. DC2FG @db0gv

This modification is read 750 times.

[top of page](#)

01-10-2000

(TM-441) QRG mod for Kenwood TM-441E

Author: Oliver, DG7XO - mail@dg7xo.de.MODIFICATION.NET

Hallo, hier eine kleine Anleitung, wie man mit dem Kenwood TM-441E einen Frequenzbereich von 340-512 MHz erreichen kann. Unter der Prozessor Platine (Frontplatine) direkt unter der "TONE-Taste" befindet sich eine Diode D209.

Dazu muss man die Mic-Buchsenmutter lösen, sowie alle Einstellregler. Danach kann man das Plastikgehäue abnehmen. Die LCD-Einheit ist nur gesteckt und kann jetzt abgezogen werden. Danach den Metallrahmen (4 Schrauben) abnehmen und die Prozessoreinheit abziehen, die aber mit 2 Schrauben noch gesichert ist !

Auf der Rückseite einfach die Diode D209 ablöten oder den einzelnet Pin hochbiegen und schon kann man von ca 340-512 MHz empfangen. Senden geht auch, nur ist mir nicht bekannt, in welchem Bereich.

Wiegesagt, die Diode ist GENAU unter der Tone-Taste !

Für entstandenen Schäden kann natürlich keine Haftung übernommen werden.

vy 73 de Oliver, DG7XO, mail@dg7xo.de

This modification is read 744 times.

[top of page](#)

19-07-1998

(TM-451) Frequency expansion for the Kenwood TM 451 E

Demontage:

At first remove the upper case-cover, then the speaker can be removed and pull the connector of the speaker.

Then remove the lower part of the case. Then pull off the 3 knobs on the front side and remove the front side paneel. Bee careful, the front paneel is fixed through 4 straps which can break. Lift the straps carefully with a little screw driver or with Your fingers then pull the front paneel forward.

On the front side of the TRX loose 1 screw and the screws of the tuning knob. Loose the display with the transparent plastic frame carefully in forward. Remove the power button to side. A metall frame is fixed with 4 screws on side. Remove screws an pull the metall frame forward. The 2 screws of the processor platine front side can now be removed. Before taking out the processor platine, remove CTSS- or DFMF-units if they are there.

The processor platine is linked with 2 connectors with the F-platine. Pull these connectors softly! Take the platine with Your fingers near the connectors.

The processor is signed with "D 6433388F" and it is an 80-pin square SMD- ic. One edge is a little cut off, here begins the pin numbering counterclockwise. Between pin 64 and 65 that is right above the marked edge is a diode with a resistor in row connected. It is a smd-diode in a black pastic case. Remove it fully or solder it off only on 1 pin. Do not remove the diode in a field which is white framed.

Write down what You do when demounting the case and mount all together. At last make a reset (described in the manual).

What is new?

TM 451 E RX ranges:

136-173,995 MHz all rasters

300-469,995 MHz all rasters

800-999,9875 MHz only 12,5 and 25 kHz Raster

TX Range: 410-469,995 MHz all Rasters

To help with this mod. You want to be looking in the area were the lithium battery is. With the battery facing you, the IC is to your left. In my 451E the IC Chip D 6433388F is not visible because of a sticker on the chip.

Refer to the schemetic if in doughbt that's what I did! Still with the battery facing you, look left and at the top of the chip and from right to left count 5, this is pin 64 and 65. Now above you'll see a resistor with white edges, and directly above you'll see the black diode! that's horizontal, just unsolder one leg.

And don't for get to rerset the rig! But mine did it automaticly Hi.

I take no responsability if you damage your radio, proceed at your own risk, but it worked for me!

This modification is read 745 times.

[top of page](#)

19-07-1998

(TM-451) TM-451E Low Power Mod

Open the upper panel, this one where you can put the ME-1

With the display front of you and the dissipator to the bottom, you will see at the upper right corner near the radiator some very small pot. VR The good one to turn for reducing power is VR102.

A screwdriver is all you need for this mod.

This modification is read 643 times.

[top of page](#)

19-07-1998

(TM-455) Solution 9k6 TM255/455

Dear OM's

This is what I found a service technical report from Kenwood acc. TM255 and TM455 9600bps Date November 8, 1994

SUBJECT: Countermessure against modulation during packet 9600bps operation.

Phenomenon:

A trouble modulation malfunction during packet 9600bps operation was found in the manufacturing process even trough there in input in the DATA terminal.

Pay heed to this trouble in replacing the analog switch IC13.

Cause:

This trouble is cuased by variation in the analog switch IC13.

Even if the 9600bps SW Tr. (Q20:DTA124EK) has been turned ON, the analog switch IC remains unstable.

Counter measure:

We decided to raise the analog switch IC13 voltage while the 9600bps SW TR. (Q20:DTA124EK) is in action by changing the chip resistor R117 in the TX-RX-unit of TM455A/E and of TM255A/E.....etc.

R117= 10K to be replaced with 3K3

So if you have problems with those two say to your dealer to ask for SERVICE TECHNICAL REPORT No. B510-94-081E page 1/2 and page 2/2

73's DE PAT KE6MIQ

This modification is read 626 times.

[top of page](#)

23-04-2000

(TM-455) TM-455A/E Change in pin diode

Author: Kenwood Communication, inc.

Service Bulletin no. 1058 (6 May 1994)

Symptom:

Some early versions of the TM-566A/E have been discovered with a bad solder connection at the final module pin diode, D601. If the impedance of this devices is too low, the power consumption for this devices goes up. This increased power consumption might cause excessive heating of the solder connections, and may result in a failure of the connection(s) after long FM transmission.

Countermeasure:

On the TX/RX unit replace diode D601 with a UM9401, change R606 to 100 ohm, change C623 to 5 pF, and C624 to 12 pF. After replacing these parts, readjust the NULL and Protection circuit using the procedure provided in the service manual.

Parts required:

Qty	Description	Part No.	Circuit Description
1	Pin diode	UM9401	D601
1	100 ohm chip resistor	RS14DB3A101J	R606
1	5 pF chip capacitor	CM73F2H050D	C623
1	6 pF chip capacitor	CM73F2H060D	C624

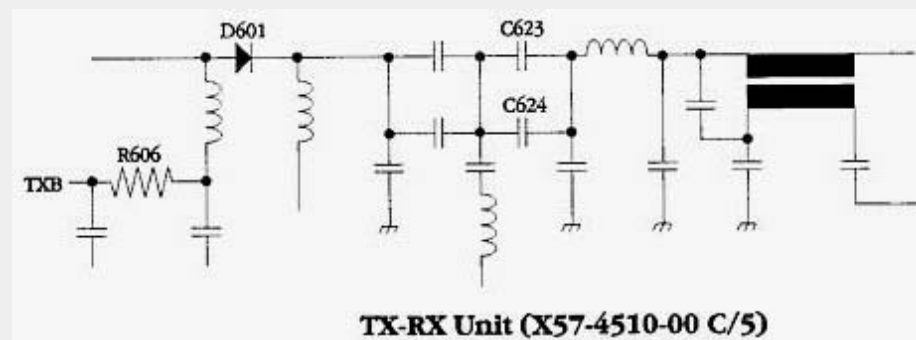

Time required for this modification is 60 minutes or less.

This modification is read 662 times.

[top of page](#)

17-11-2000

(TM-461) Expand the TX to 420 to 450MHz

Author: SM4RNA, Anders - sm4rna@telia.com.MODIFICATION.NET

- Take top cover off.
- Locate the green wire called W2.
- Cut and insulate both ends.
- Do a full re-set of the radio.

19-07-1998**(TM-531) TM-531 & 9600 Baud**

To use the Kenwood TM531 with a g3ruh 9600 Baud modem:

1. PLL-unit modification:
Change R56 to 3k.
Change C56, 57 to 10uF/10v.
2. Main board:
Remove C55, 70, 118.
3. TXA:
TXA via 150k to MO (pll-unit).
4. RXA:
RXA to pin 12 ic2 (main board).
5. Change C34 (ruh board) to 1uF (mkm).
6. You'll need a eprom COA.
7. Solder a ptc (siemens b30-0845-05 (60 Gr. Celius)), on the VCO-unit.

73's, Ed. PE1NAT

I received your mail today morning, on Dec., 15.
I'm using TM-531 on G3RUH type 9600bps modem.
We ha local aria network using 9600bps modem.
It is working well, now. But, beginning of this network is not easy.

You can connect G3RUH type modem as follow.

1. TXA

Take off the shielding plate under the main PCB.

Search for VR3 on main PCB.

VR3 is indicated on PCB "MAX DEV" for adjust maximum deviation.

The slider of this VR is connected to MD pin of VCO through C55 capacitor.

Connect TXA to MD pin of VCO using resister(56k to 100kohm) and capacitor 0.1uF, connected in series, like follow.

```
TXA ---II-----///----MD(VCO)
      0.1uF      56k to 100kohm
```

If you get weary to take off shielding plate, you may connect the TXA to hot end of VR3, using the resister and capacitor as aforesaid.
TM-531 & 9600 Bps.

2. RXA

Search for IC2 on main PCB.

IC2 is a 16 pin hybrid IC for IF AMP and discriminator.

You can discriminate pin number of this IC from printed symbol on the main PCB, and grand pin.

Pin 2 and 16 is connected to grand.

pin 5 is output for ceramic filter(CF1), and pin 7 is input from the filter.

Connect RXA to pin 12(DET) directly.

9600bps on 1200MHz band is very difficult. Because, frequency stability is not enough. And, IF band width is not enough, too.

We are developing SMC transceiver for G3RUH modem on 144,430,1200MHz band.

It has high stability PLL OSC(about 1ppm) and good linearity modulator (voltage controlled X'tal OSC)

Sammy JE1RLA @ JE1RLA

19-07-1998**(TM-531) Measure deviation using TM231,431,531**

From AA9HX - ON7WP @ ON7RC.BT.BEL.EU

To all technical kenwood freaks,

All people clever enough to know that they have to do something about the tremendous amount of people constantly overdeviating, mainly all using off the shelf kenwood equipment, coming straight from the factory adjusted at 6,7 or EVEN 8 KHz Peak deviation !!!!

This article describes how YOU can use your kenwood transceiver TM231, TM431, TM531 and apparently also the TMX41 range to measure ON THE AIR deviation of repeaters and all other stations...

The principle of measurement is indeed very simple and DOES NOT NEED ANY MOD INSIDE YOUR TRANSCEIVER NOR EVEN OPENING IT !!!

Your microphone connector provides at pin 6 an audio output, straight from the FM detector. As all kenwoods use the same detector chip and coil, all give the same output voltage for a given deviation. The output at this pin 6 (and pin 8 as a ground) is linear up to 5 KHz deviation. As the IARU standard for amateur radio communication is 3 kHz peak deviation, this range from 0-5 KHz is perfect. Connect your oscilloscope to pin 6 and 8 as ground, 400 mV peak to peak voltage corresponds to 3 kHz deviation. So 200 mV is 1,5 KHz deviation and so on.

CTCSS deviation should be around 300 Hz although most kenwood transceivers only react well from 400 Hz.

Packet should be set to approximately 2 KHz.

And additional an extra tip for improving the modulation quality of your kenwood TMx31:

As the microphone amplifier is quite overdriven, modulation sounds very rough, due to extreme clipping of the signal, especially a nuisance in noisy environments, such as when mobiling in a not so luxury car.

This can become much better just by changing or in some cases adding the input resistor of the microphone amplifier. Different types are used depending on the market the transceiver was designed for. As they still believe at kenwood that europe uses a 25 kHz raster and the states 20 kHz, europe types get lesser attenuation before the amplifier than stateside trx's.

Hey You there at the kenwood factory reading this: whole europe is changing to a 12,5 kHz raster, so will you please stop delivering your transceivers and portables with a deviation standard dating from jurassic park time !!!

schematic info:

Deviation potmeter TM231 VR3 and decrease R64

Deviation potmeter TM431 VR2 and decrease R58

Deviation potmeter TM531 VR3 and decrease R60

So remember 3 kHz is the standard, do not discuss whether it is good or not, IT IS THE STANDARD FOR AMATEUR RADIO.

It is the only way to live peacefully and to prevent wars between adjacent repeater or simplex channels.

(and by the way, narrowing the receiver bandwidth extends your range...)

Im looking forward to all comments, and I hope that somebody of the kenwood technical crew also will read this and do something about the adjustment of the new transceivers...

73 from Pedro M.J. WYNS AA9HX, ON4AWQ, ON7WP,

full licensed transceiver doctor... HI !

ON7WP @ ON7RC.BT.BEL.EU

This modification is read 482 times.

[top of page](#)

20-04-2000

(TM-531) TM-531A 20 MHz offset modification

Author: Trio-Kenwood Communication, inc.

Service Bulletin no. 956 (9-1-1990)

The TM-531A offset can be changed from 12 MHz to 20 MHz by performing the following modification. Once the modification is done, only 20 MHz can be selected. It is recommended that this modification be performed at the dealer level since they have the correct tools to disassemble the transceiver.

Required tools:

Spanner wrench (W05-T004) for mic jack nut
11mm wrench (W05-T009) for rotary encoder nut

1. Disconnect the power supply and antenna.
2. Remove the top and bottom covers (2 screws on each cover).
3. Pull the 3 knobs off the front panel.
4. Remove the nut from the microphone jack.

5. Remove the nut from the rotary encoder.
6. Remove the 4 screws from the front panel assembly (1 on each side, 1 on top, and 1 on the bottom).
7. Pull the front panel off the body of the transceiver.
8. Remove the 3 screws from the TX-RX board (X57-3340-11 B/2).
9. Pull the board off the body of the transceiver, but do not disconnect the wire harness.
10. Locate D208 on the foil side of the TX-RX board (figure 1).
11. Desolder and remove the diode.
12. Assemble the transceiver by reversing steps 1 - 9.

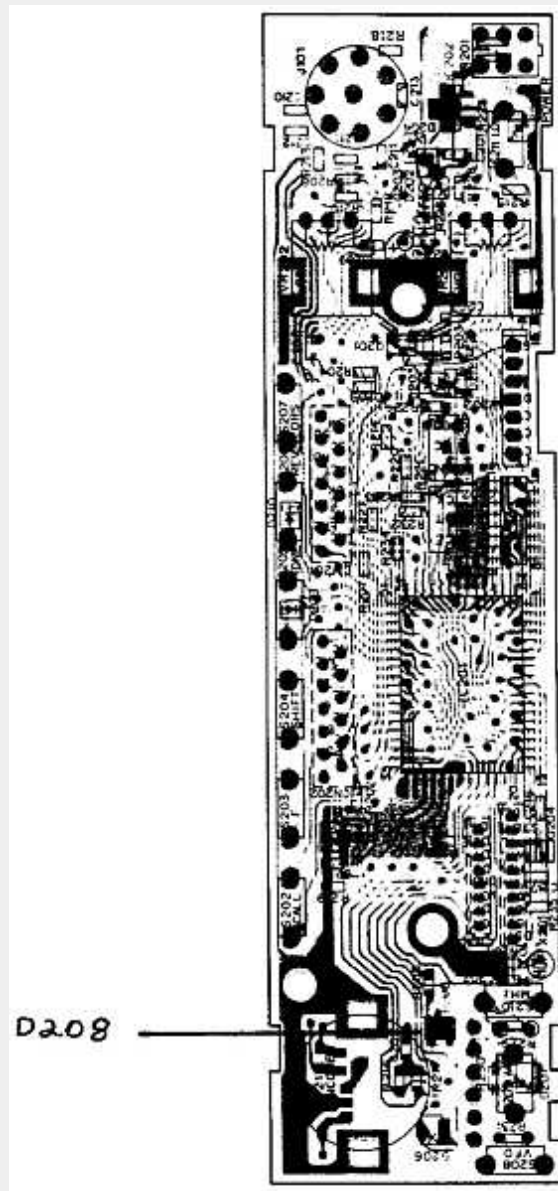

This is an optional change that is not covered under warranty.
Time required to perform this modification is ½ hour.

This modification is read 491 times.

[top of page](#)

19-07-1998

(TM-621) TM-621 to 9600 baud

The mods to do 9600 baud packet using a K9NG or G3RUH modem are fairly simple to do with the Kenwood TM-721/621 radios. Look at your schematic.

Receive data is taken from the discriminator output. Look for the 3.3K resistor coming off pin 9 of the last IF stage. Connect a 1K series resistor from the modem RX input to the junction of the .001 and 3.3K.

PTT is taken off pin 2 on the microphone connector. TX data is fed through a 1K series resistor to the top of VR3 (the deviation control).

This method has been tested and works quite well on 440 MHz and 220 MHz. The mods haven't fully been tested on the 2 meter portion of the radio.

The TM-731 radio is different enough to cause problems. What needs to be done is to add another RX Mute transistor. (Look at the schematic and see how the TX deviation is shorted to ground during receive.) Use a plain NPN and a pair of 10K resistors (copy the

one used on VR3 in the schematic). Take the TX data and feed it to the collector through a series 1K resistor, and then feed that through another 1K resistor to the wiper of the deviation pot. This was a result of Kenwood changing the deviation pot value from 10K to 100K. (It wasn't broken, but they fixed it anyway.)

As with any modifications, take reasonable care, and I won't be responsible if you trash your radio. BE CAREFUL; it is full of surface mount devices.

This MOD file was written by Jeff, WA6FWI @ WB6YMH. #SOCA.CA.USA.NA
Schematics and layouts are available by request through the author.

This modification is read 464 times.

[top of page](#)

08-08-2001

(TM-621) Modulations mod for TM-261

Author: KC8EVB - kc8evb@letarc.net. MODIFICATION.NET

The modulation that is set on the TM-261A from the factory isn't always up to snuff. After having to repeat myself for about the 50th time in a month, I decide it was time to "turn it up".

1. Open the top of radio by removing to 2 screws and pulling up from the back of the lid.
2. Find VR3 and adjust clockwise until desired audio level is reached. (Mine is set to about > up)
3. Put the lid back on and stop repeating yourself.

73, KC8EVB kc8evb@letarc.net

This modification is read 568 times.

[top of page](#)

21-04-2000

(TM-631) TM-631/731A Memory loss modification

Author: Kenwood Communication, inc.

Service Bulletin no. 972 (8-8-1990)

Some TM-631/731A owners have reported that the transceiver intermittently loses its memory channel information when the power switch is turned on. The following modification will absorb pulses on the CPU interrupt line (INT4) and reconfigure the backup switching circuit to avoid unintentional memory loss.

Read all instructions before proceeding. Do not attempt this modification if it is beyond your capability.

Required parts: ZKIT-731MEMO

The kit contains:

Part #	Description	QTY.
NJM78L06A	6 V AVR	1
1SS133	Diode	1
MTZ3.0JB	3.0 V Zener diode	1
CE04NW0J221M	220 μ F, 6.3 V Electrolytic capacitor	1
C91-0457-05	0.022 μ F ceramic capacitor	1
CK45B1H103K	0.01 μ F ceramic capacitor	1
RD14BB2C103J	10 Kohm, 1/6 watt resistor	1
RD14BB2C102J	1 Kohm, 1/6 watt resistor	1
RD14BB2C472J	4.7 Kohm, 1/6 watt resistor	1
RD73FB2A472J	4.7 Kohm, 1/10 watt resistor	2

1. Disconnect the power supply, antenna, and microphone.
2. Remove the top and bottom covers (12 screws). Do not damage the speaker wires when removing the top cover.
3. Pull the Main Encode, Volume, and Main Squelch knobs off the front panel. If a knob does not easily pull off, wrap a cloth around the knob and carefully pull it off with a pair of pliers. Be careful not to crush or scar the knob.
4. Remove the two brass colored screws from the top of the plastic front panel. Figure 1.
5. Gently lift the two tabs on the bottom of the front panel and then pull the front panel off the transceiver. Figure 2.

6. Remove the two black shades from the Balance and Sub-Squelch controls. Figure 3.
7. Remove the three brass colored screws from Control board B/3. Figure 3.
8. Remove the brass colored screw that is mounted on the front panel chassis above the Power switch. Figure 4.
9. Remove the brass colored screw that is mounted on the front panel chassis to the right of the microphone jack. Figure 4.
10. Carefully pull Control board (B/3) away from the body of the transceiver.
11. Disconnect the two "wire type" cables from the body of the transceiver.
12. Disconnect the two flex cables from the Control board. The flex cables simply pull out of the connectors.
13. Remove IC102 from the Control board. Since this device is glued to the board, use a needle tip tool to lift each pin as you melt the solder. Then pry the chip off the board with a craft knife. Figure 6.
14. Remove any excess glue and solder from the area where IC102 was located.
15. Remove chip resistor R103. Do not melt connector CN101. Figure 6.
16. Cut the foil pattern between connector CN101 and chip capacitor C102. Make the cut as close to connector CN101 as possible. Figure 6.
17. Prepare the 1SS133 diode for installation. The cathode lead will be cut and bent 90°. The diode must lay flat on the board and the cathode lead cannot touch the cut in foil. Once the diode leads are prepared, solder the diode in place. Figure 7.
18. Prepare the NJM78L06A 6 V AVR for installation as shown in figure 8. The leads to this device are vary soft and can break when bent too often. Make each bend only once.
19. The 6 V AVR will be mounted in place where IC102 was located. The board must first be prepared for the installation. Remove the protective coating from the foils as shown in Figure 7. These are the foils that where connected to pins 2 and 7 of IC102 and the ground foil that runs under the device.
20. Place the 6 V AVR on the board and make sure the leads contact the foils. Cut the leads to size and then solder the device to the board. Figure 9.
21. Prepare the 0.01 μF capacitor, 10 Kohm resistor, and 4.7 Kohm resistor for installation. Place the parts on the board to size and cut the leads. Once the parts are prepared, solder them to the board. Figure 10.
22. Locate R105. If the component is 47 Kohm, change it to a 4.7 Kohm chip resistor. The component's value can be determined by the numbers written on the case. If the device is labeled 473, it is a 47 Kohm resistor and needs to be replaced. If the device is labeled 472, it is a 4.7 Kohm resistor and does not need to be replaced. Figure 10.
23. Straighten the tabs that hold the LCD assembly to the Control board. Carefully pull the LCD assembly off the Control board (do not break the flex cable). Figure 5.
24. Remove C123. This chip capacitor is located in the corner of the board under the LCD assembly. Figure 11.
25. Remove the protective coating from the foils as shown in figure 11.
26. Place the 3.0V zener diode on the board. Size and cut the diode's cathode lead. Solder the lead to the board. Figure 12.
27. Place the 1K ohm resistor on the board. The body of the resistor must be parallel to the diode. Size and cut the resistor's left hand lead. Solder the lead to the board. Figure 12.
28. Bend the diode's anode lead and solder it to the resistor's right hand lead. Do not allow the leads to touch the board. Trim the leads after soldering. Figure 12.
29. Prepare the 0.22 μF capacitor for installation. Place the component on the board to size and cut the leads. Figure 12.
30. Solder the left hand lead to the junction of the zener diode and 1 K ohm resistor. Do not let the connection touch the board. Figure 12.
31. Solder the right hand lead to the board as shown. Figure 12.
32. Replace C107 with the 220 μF electrolytic. C107 is located between the Main and Sub rotary endoders. Figure 3.
33. Mount the LCD assembly an the Control board and bend the four tabs to hold it in place. Make sure the LCD does not touch the leads of the new parts.
34. Connect the two flex cables to the Control board and then plug the two "wire type" connectors into the body of the transceiver.
35. Mount the Control board on the body of the transceiver and secure it with the three brass colored screws that go through the Control board. Be careful not to pinch any wires.
36. Install the brass colored screw that goed above the power switch and install the brass colored screw that goes to the right of the microphone jack.

37. Install the two black shades on the Balance and Sub-Squelch controls.
38. Slide the lock, balance, and Sub-Squelch controls to the left.
39. Slide the Lock, Balance, and Sub-Squelch knobs on the plastic front panel to the left.
40. Gently install the plastic front panel on the front panel assembly. Do not force the installation.
41. Install the two brass colored screws on the top of the plastic front panel.
42. Install the Main Encode, Volume, and Main Squelch knobs.
43. Remove the two screws from the small board where the positive power lead connects on the bottom of the transceiver.
44. Solder the remaining 4.7 Kohm chip resistor to the foil side of the board. Figure 13.
45. Mount the board and install the covers on the transceiver.

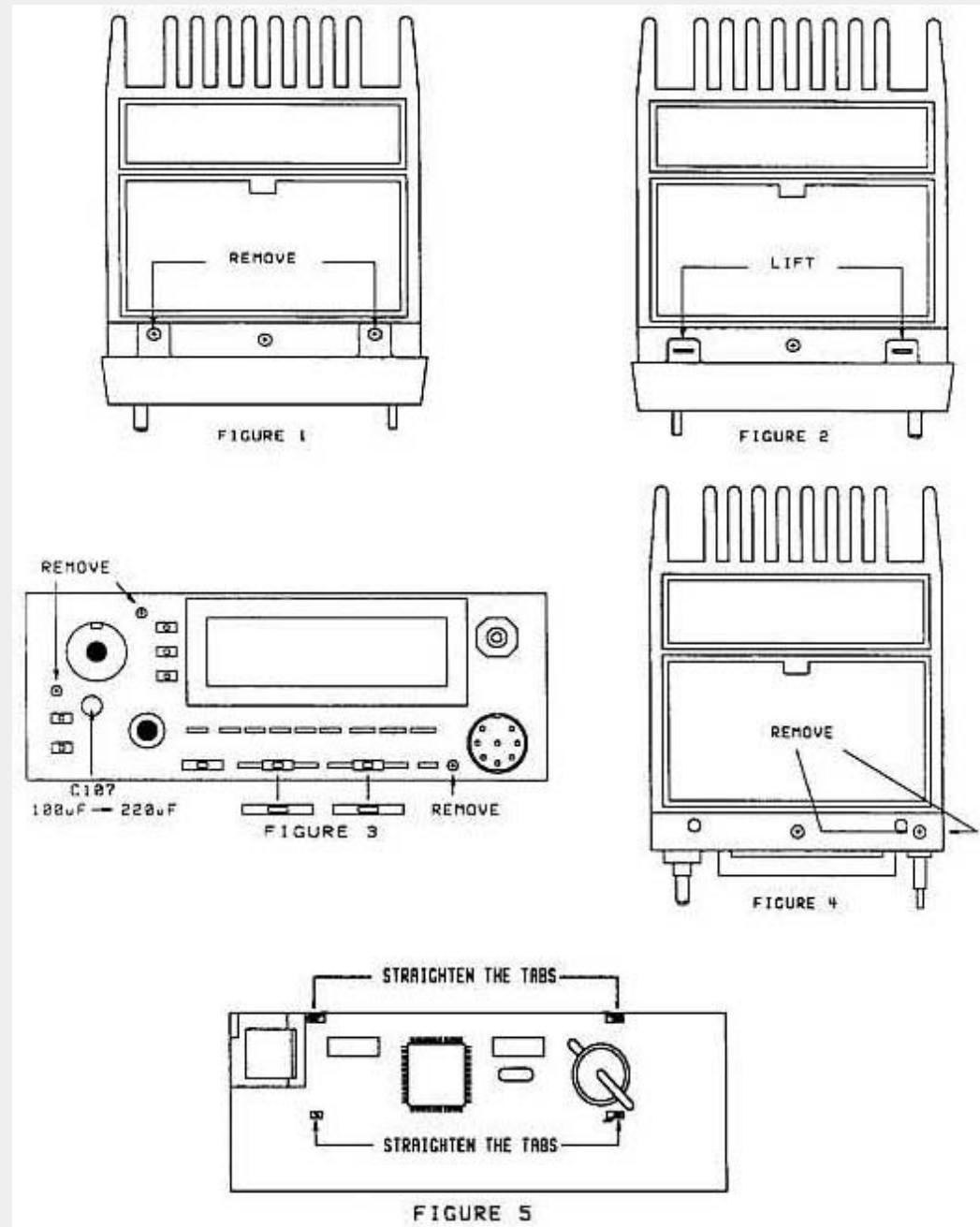

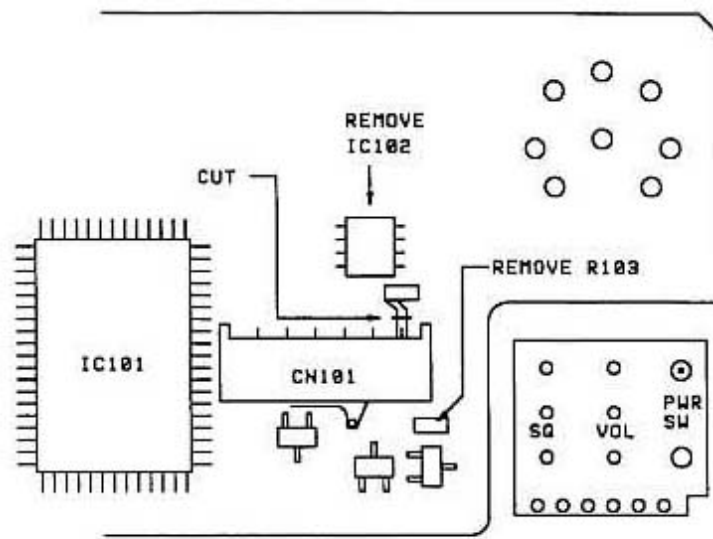

FIGURE 6

REMOVE PROTECTIVE COATING

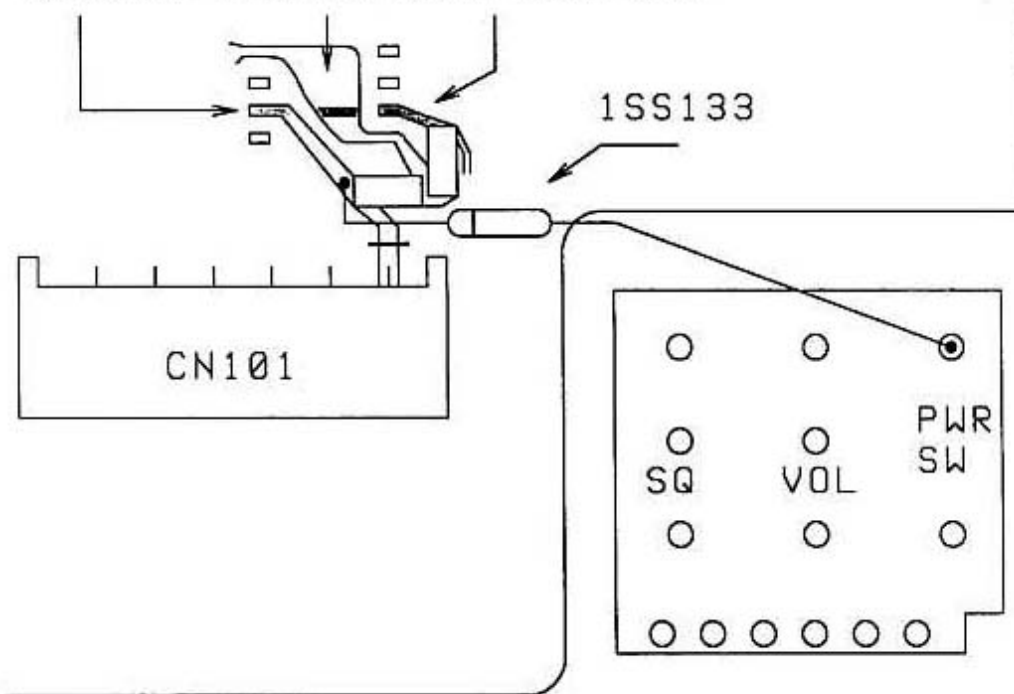

FIGURE 7

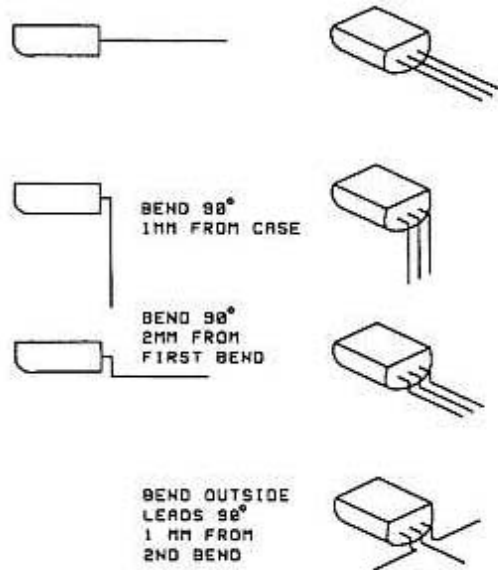

FIGURE 8

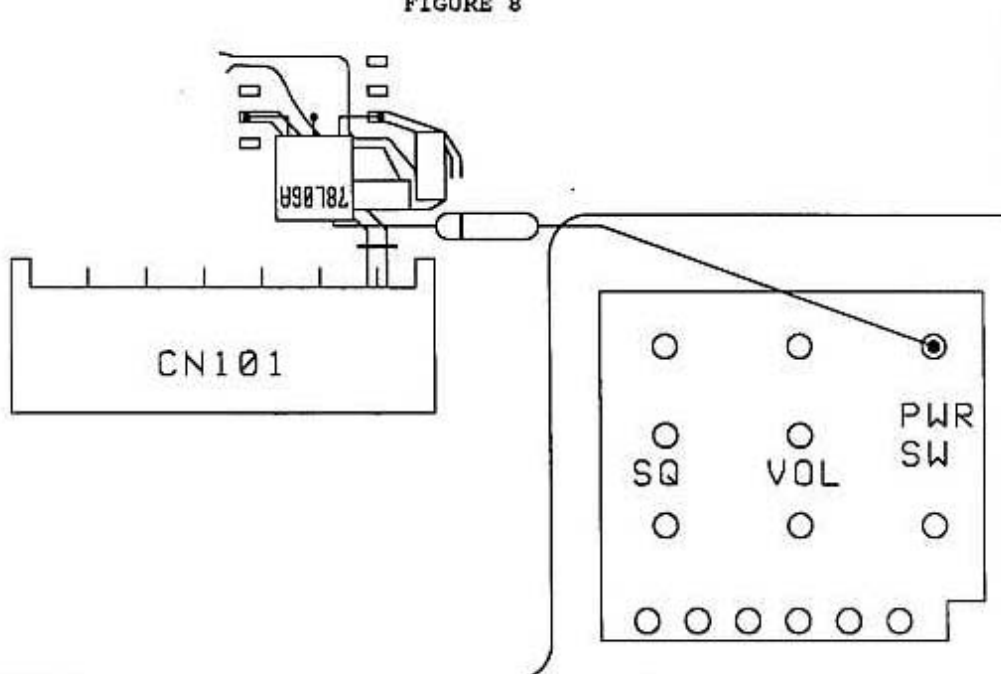

FIGURE 9

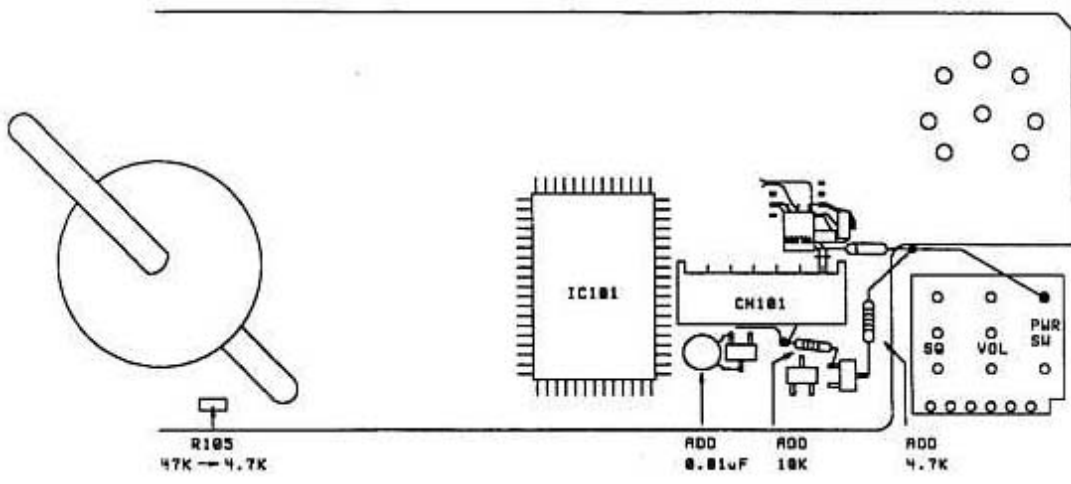

FIGURE 10

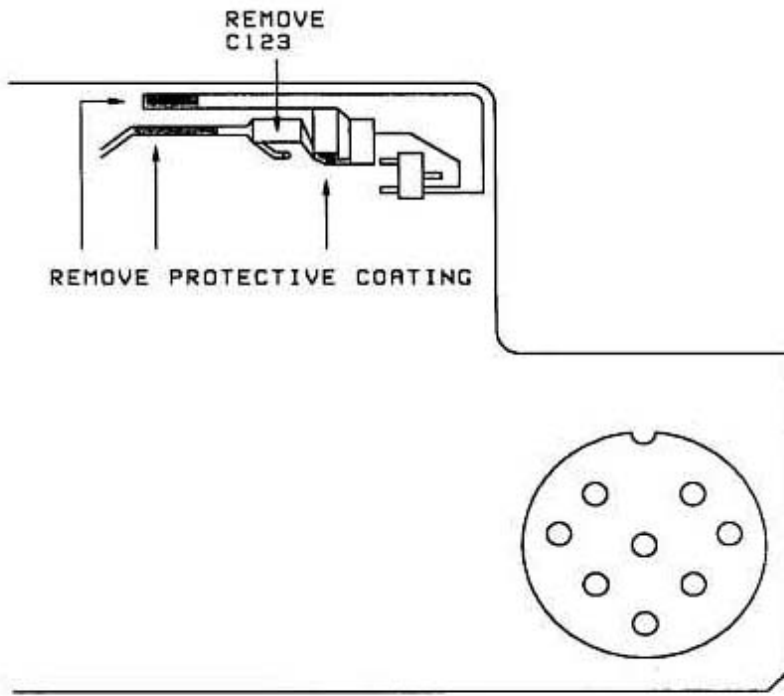

FIGURE 11

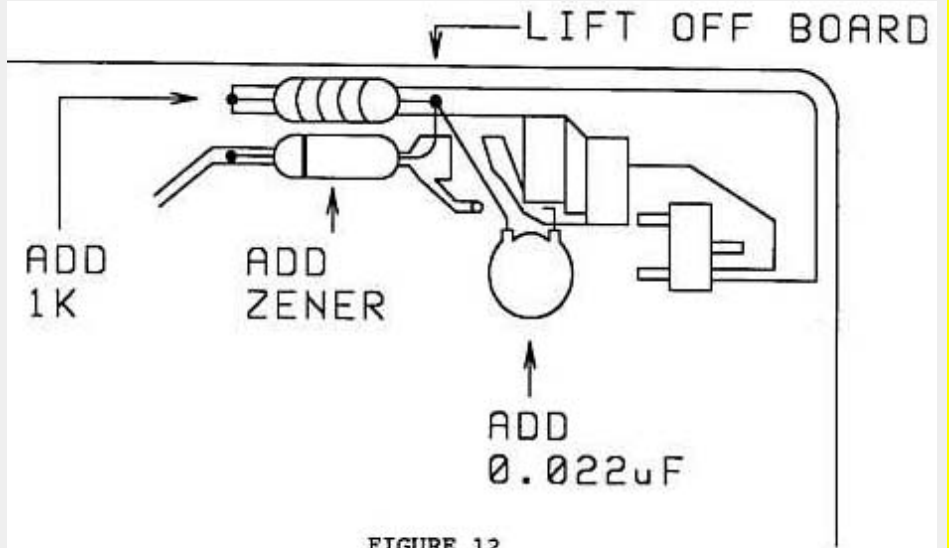

FIGURE 12

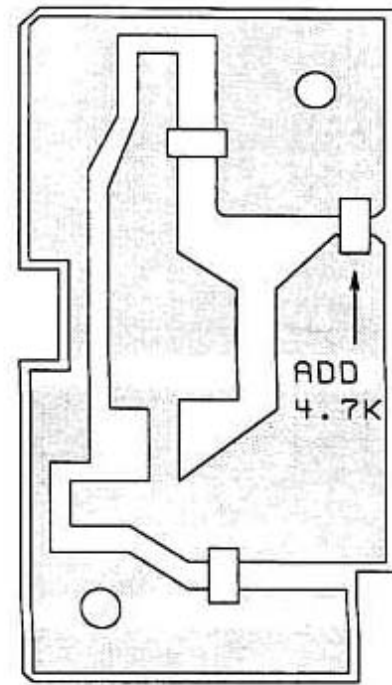
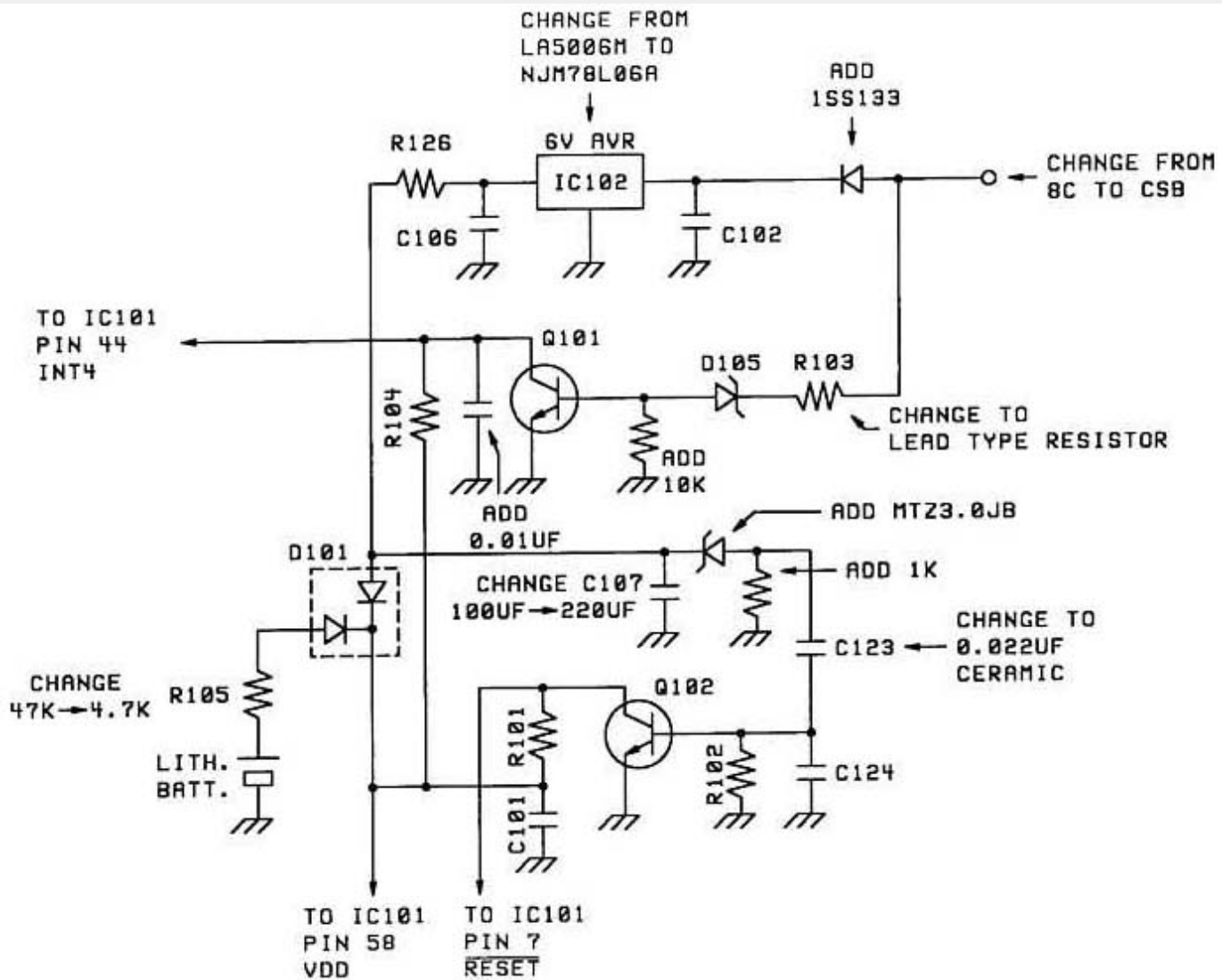

FIGURE 13



This modification may be covered under warranty.
Time required to perform this modification is 1 hour or less.

This modification is read 481 times.

[top of page](#)

21-04-2000

(TM-631) TM-731A/631A Final board C17 change

Author: Kenwood Communication, inc.

Service Bulletin no. 977 (8-8-1990)

Bypass capacitor C17 on the 144 MHz Final board has been changed in production from a "flat package" chip capacitor to a "cylindrical package". The change prevents the capacitor from fracturing. If C17 fractures, the output of the power module can burn C17, R11, and L6. Additionally, Q1 on the TX/RX 144 MHz board may be damaged.

C17 should be changed as a part of routine maintenance when a TM-731A/631A is received for service. The new style capacitor part number is CK41FY1E102M. For field service, a 0.001 μ F, 25 V disc ceramic capacitor can be used.

The production change started at serial number 108xxxx.

To replace C17:

1. Disconnect the power supply and antenna.
2. Remove the top cover. Do not damage the speaker wires.
3. Remove the shield plate from the VHF Final unit (4 screws). Figure 1.
4. Remove the 7 screws that secure the final board to the chassis. Figure 2.
5. Remove the 2 screws that secure the power module to the chassis. Figure 2.
6. Remove the 2 screws that secure the VHF antenna coax to the heat sink.
7. Desolder the center conductor and shield of the VHF antenna coax from the final board and pull the coax out of the heat sink. Figure 2.
8. Desolder the terminal next to pin 3 of the power module. Figure 2.
9. Rotate the board toward the front of the transceiver to expose the foil side of the board.
10. Inspect the solder at the terminals the antenna coax was soldered to. They may need to be resoldered.
11. Replace C17. Figure 3.
12. If you are serving a TM-731A/631A that has been damage, check R11 and L6. The coil may have pin hole burn marks in its insulation and the resistor may be open. In addition, check Q1 on the RX/TX (144 MHz) board. If it is damage, the receiver sensitivity will be low.
13. If the Final board has been burned, it can be repaired. The carbon must be completely removed from the board to prevent the board from burning any further (carbon tracking of the RF signal). The burned area should be filled with epoxy an the lands must be repaired.

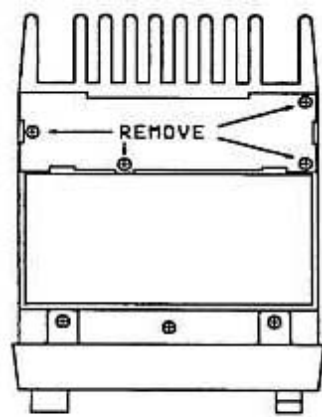

FIGURE 1

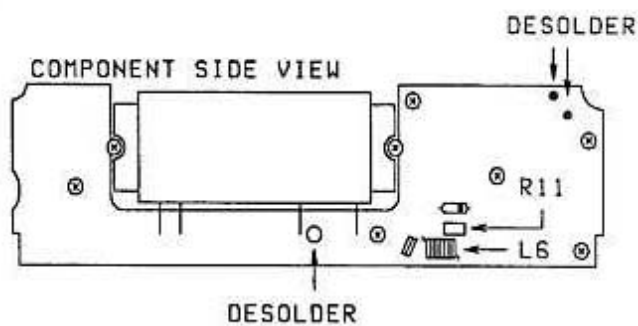

FIGURE 2

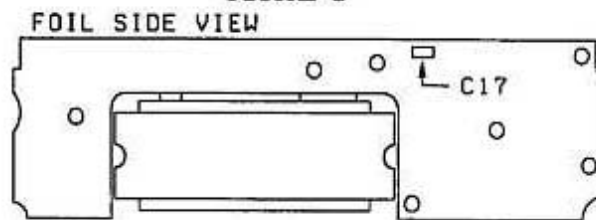

FIGURE 3

This modification may be covered under warranty during the warranty period.
Time required to perform this modification is 1 hour or less.

This modification is read 466 times.

[top of page](#)

23-04-2000

(TM-642) TM-642/742/942A Microprocessor change

Author: Kenwood Communication, inc.

Service Bulletin no. 1040 (10 February 1994)

Symptom:

Due to a recent rule change by the FCC it is no longer possible to supply transceivers, or provide replacement microprocessor that would allow a transceiver to receive in the 800 MHz band.

Corrective action:

The microprocessor program of IC5 has been modified to prevent 800 MHz band reception. Production has been changed beginning with serial number lot 510xxxx. Units produced after this point will not be capable of 800 MHz reception.

Parts required:

Qty	Description	Old part No.	New Part No
1	Microprocessor	HD6433388A22F	HD6433388A25F

Procedure:

When ordering a replacement microprocessor you will be supplied with the new version. Please make sure your customer understands the limitations of this new

This modification is read 465 times.

[top of page](#)

23-04-2000

(TM-642) Microprocessor Change, TM642/742/942

Author: Kenwood Communication, inc.

Service Bulletin no. 1042 (28 March 1994)

This bulletin supercedes ASB-1033.

Symptom:

Reports of problems with microprocessor lock-up when using S-meter squelch, problems with storage/recall of PL tone frequencies of 203.5 Hz. and/or 114.8 Hz., or problems with a lack of transmit on the UHF band modules during Remote operation can be corrected using the changes noted in this bulletin.

Notes:

1. All TM-642A transceivers work fine and do not require any changes.
2. TM-742/942's that exhibit any of these symptoms with serial numbers between 412XXXX and 509XXXX need only change IC1 on X53-3460-21 B/2.
3. TM-742/942's that exhibit any of these symptoms with serial numbers of 412XXXX and below must also change IC1 on X54-3130-11.
4. TM-742's with serial numbers of 509XXXX and greater have had these changes incorporated in production.
5. Some TM-742's and TM-942's below serial number 509XXXX were returned to Japan for modification. If the unit that you have has a black dot on the box near the serial number it has already been modified and requires no further action.

Parts Required:

Qty	Description	Old Part No.	New Part No.	Circuit Description
1	Microprocessor	HD6433388A07F	HD6433388A22F	IC-1
		or		
		HD6433388A14F		
1	Microprocessor	HD404719A26H	HD404719A32H	IC-1

Caution: This modification requires advanced surface mount soldering equipment that is rated for CMOS circuits. It also requires familiarity with advanced surface mount soldering techniques. If you do not have the proper equipment or knowledge do not attempt this modification yourself.

Attempting to remove and replace either IC without the proper equipment and techniques can easily damage the circuit boards and void your warranty.

Seek qualified assistance from your closest Kenwood Service Center (Long Beach, CA, or Virginia Beach, VA).

Time required for this modification is 90 minutes or less.

This modification is read 463 times.

[top of page](#)

19-07-1998

(TM-701) TM-701A repeater cross-band modification

Perform the following modifications to allow the TM-701A to operate in the repeater cross-band mode.

MODIFICATION:

1. Disconnect the power supply and antenna.
2. Remove the top and bottom covers (12 screws). Disconnect the speaker wire from the transceiver.
3. Locate the green jumper wire show in figure 1. Using a sharp pair of wire cutters, cut the jumper in half. (green jumper)

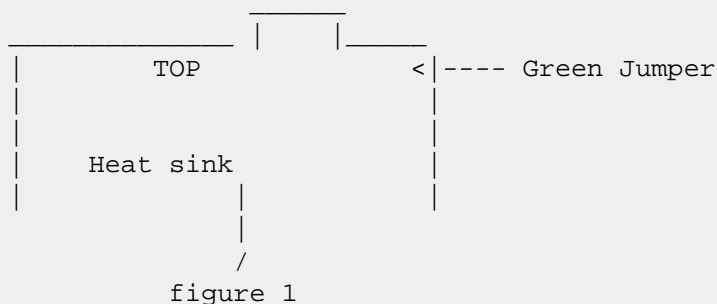

CAUTION:

Cutting the green jumper allows the TM-701A to transmit from 142 to 151.995 MHz. Protect your license by only using

frequencies that you are authorized to transmit on.

4. Solder a jumper wire to the foil side of the TX-RX board as shown in figure 2.

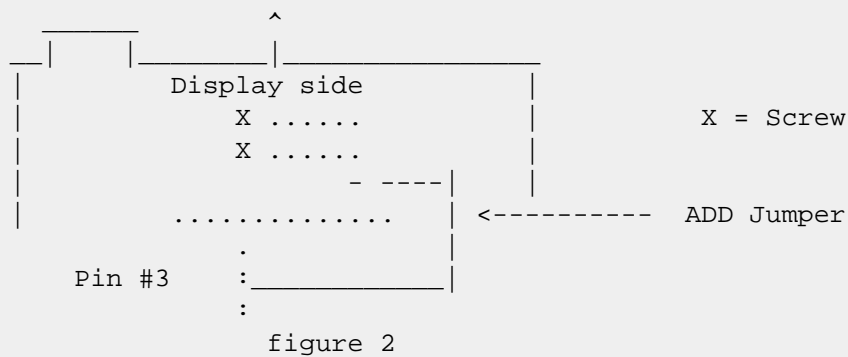

5. Assemble the transceiver by reversing steps 1 -2.
6. Reset the microprocessor by holding in the MR key as the power is turned on.

The repeater cross-band operation allows the TM-701a to receive on one band and re-transmit the signal on the other band. The TM-701a alternately displays the two bands until a signal is received. The transceiver will then display the band that is re-transmitting the signal. The SHIFT function cannot be used during the repeater cross- band operation. If the TONE or CTCSS function is required, only one ETA tone can be used for the two bands.

OPERATING PROCEDURE

1. Select the operating frequencies for both bands.
2. Set the squelch control to the threshold point. The TM-701a will transmit in the repeater cross-band mode if the squelch control is set too low or a signal is received.
3. Place the transceiver in the duplex mode (F + DUP).
4. Press the F key for longer than one second. The F indicator will flash.
5. Press the LOW key. The transceiver will now enter the repeater cross-band mode of operation.
6. To cancel the operation and return to the VFO mode, press the VFO key.

Figure 2

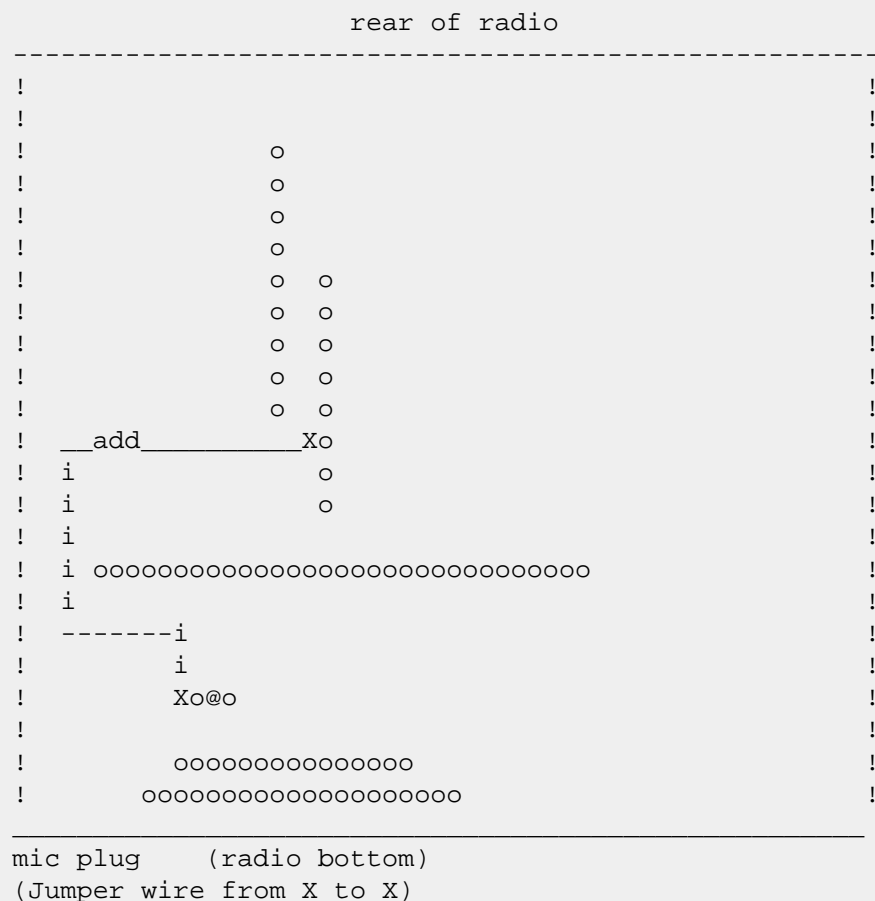

19-07-1998

(TM-701) TM-701 transmitting and receiving from 136-175MHz

The Kenwood TM-701 A is capable of transmitting and receiving from 136-175 MHz. and from 340-512 MHz. when the following mods.

Cut the GREEN jumper wire on the Control PC Board behind the front panel.

The control PCB # is X57-3350-00. Add Diode D207 and D 209 (1ss181 or equiv) a 1n914 should work fine. Anode goes to the switches and the cathode to the IC (IC201).

2. Reset the microprocessor by holding in the "MR" key as the power is turned on.

to access the Control PCB:

1. remove top bottom covers.
2. remove knobs pulling them straight off of the front panel.
3. Remove plastic faceplate.
4. remove 4 screws on front panel metal spacer and remove panel.
5. remove plastic panel/LCD by pulling straight off of the rig toward front.
6. remove the 3 screws from the Control PCB and pull straight off of the chassis.
7. Diodes mount on the back of the PCB at S205 and S209. The Andoe goes toward the switches and the cathode goes away from the switches.
D209 goes to S205 (TONE switch)
D207 goes to S209 (MR switch)
D208 goes to S204 CAUTION remove D208 only if you want to change the split from +- 5 Mc to +- 1.6 and - y6 Mc (european split).

replace all parts in reverse order. There is no RF circuit adjustments needed for this mod.

If there are any questions please call me at N4LDG PBBS Miami or write me at 11102 S.W. 117 Street Miami, Fl 33176 Hope you can now enjoy a nice rig!

John KA4ZAY Miami

This modification is read 703 times.

[top of page](#)

20-04-2000

(TM-701) TM-701A Intermittent memory loss

Author: Trio-Kenwood Communication, inc.

Service Bulletin no. 966 (4-4-1990)

Some TM-231A owners have reported that the transceiver intermittently loses its memory channel information at power on. The following modification will absorb pulses on the CPU interrupt line (INT4) and reconfigure the backup switching circuit to avoid unintentional memory loss.

This modification should be performed on a Dealer level as they have the correct tools to disassemble the transceiver.

Required parts:

220 μ F, 6.3 V Electrolytic capacitor	CE04NW0J221M
0.01 μ F ceramic capacitor	CK45B1H103K
0.022 μ F ceramic capacitor	C91-0475-05
2.2 Kohm chip resistor	RK73FB2A222J
1 Kohm carbon resistor	RD14BB2C102J
3.0 V Zener diode	MTZ3.0JB

1. Disconnect the power supply, antenna, and microphone.
2. Remove the top and bottom covers (12 screws). Disconnect the speaker plug when the top cover is removed
3. Remove the knobs from the front panel.
4. Remove the nut from the microphone jack and the 11mm nut from the channel selector switch.
5. Remove the 4 screws that secure the front panel to the body of the transceiver.
6. Pull the front panel off the transceiver to expose the Control board.
7. Remove the 3 screws from the Control board. Gently pull the board off the transceiver.
8. Perform the changes shown in the accompany diagram. C202 is on the component side of the Control board. All other work will be done on the foil side of the board.

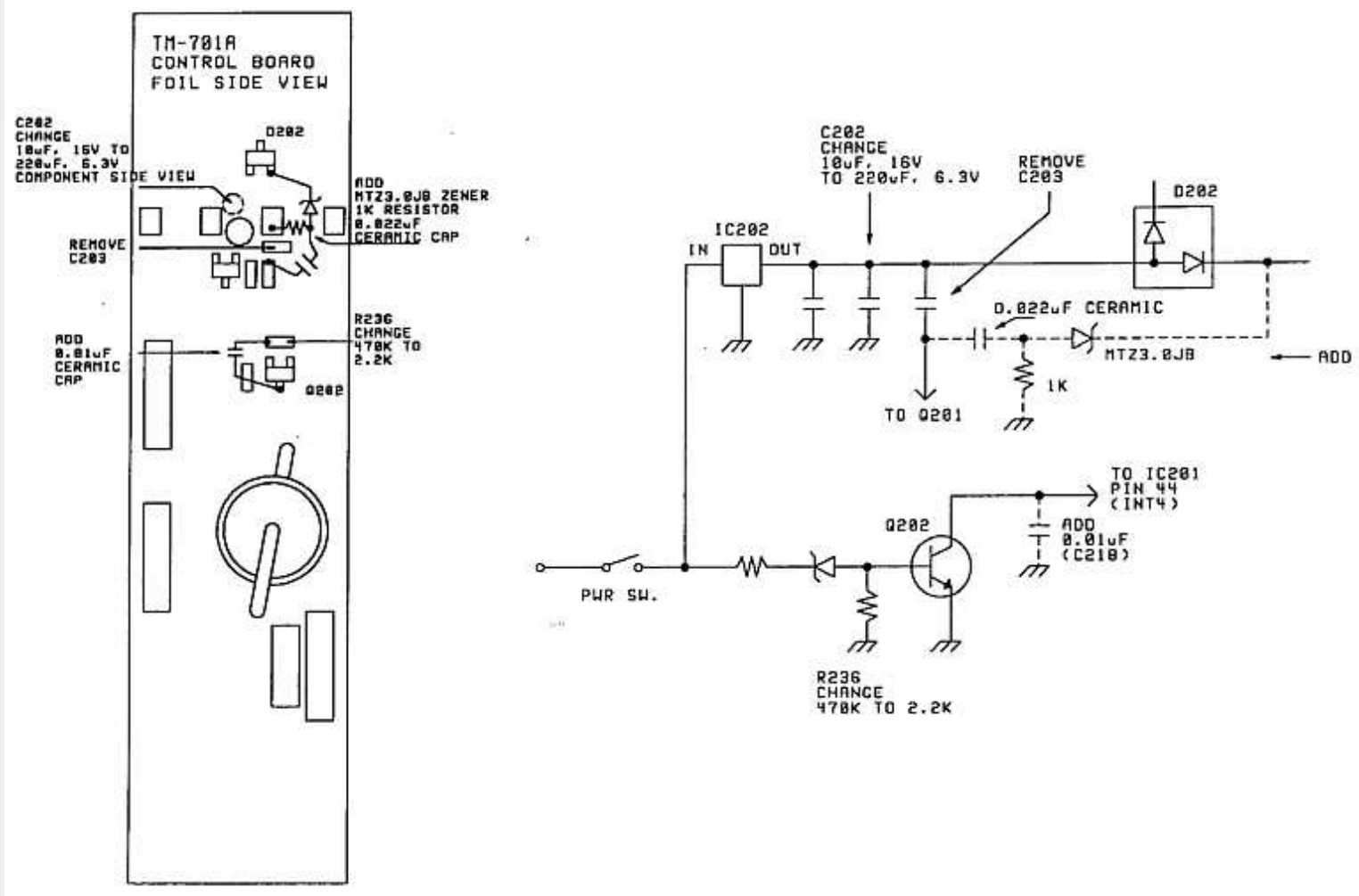

This modification may be covered under warranty.
Time required to perform the modification is 1 hour or less.

This modification is read 642 times.

[top of page](#)

19-07-1998

(TM-702) KENWOOD TM-702 to 9600 baud

Traduction by IK6SBE

The following description refers to the modification of RTX double band KENWOOD TM702E with the purpose of enabling the operation at 9600 Baud with the use of modem G3RUH.

The radio functions very well and herebelow the details.

Please note that i have made the necessary connections on the main grid, souldering side, on minus of the PTT.

For the reception i have connected the audio plug for the two meters directly on the PIN 12 of IC 11, and for the 70cm directly on the PIN 12 of IC 3.

For the trasmission on 2 meters i made the contact between the resistor SMD R70 of value 0 and the trimmer VR4 while for the 70cm i made the contact between the resistor SMD R67 with value 10K and the trimmer VR3. I souldered the plug on PTT directly on the back of the microphone plug on PIN 2.

For the connections i have used earthed 5 poles cable and earthed it on the MIC AMP earth, thus on PIN 1 but earthing can be done anyhow.

Initially i have tried to keep together the connections of the two bands thus using the same conductor for the RX of the the 2 meters and the RX of the 70 cm as well for the TX.

However i have obtained etter results during transmission with separate connections. This explains the use of 5 poles cables.

Eventually the afore mentioned cable was been inserted through the same hole of the power supply cable.

Of course i have removed the cut protection rubber on the hole.

For the utilization of one band or the other , i commute the connections from the radio at the inlet of the modem in the TNC. That is all.

I remain at your disposal for further clarification.

Ciao from Lino ik3ngu@i3xty of Treviso

This modification is read 714 times.

[top of page](#)

19-07-1998

(TM-702) KENWOOD TM-702E & mods. for function transponder

TRADUCTION BY IK6SBE

I will explain the modification necessary to operate TM702E as a true transponder.

Open the radio from the lower side. Lay it on the table with the front side towards your chest. You will see six screws that support the circuit card. Refer to the nearest screw from the front at 2 cm on the left there is a tin place in proximity of a brown resistor mounted horizontally. Solder a piece of wire on the tin place. The other point where to solder is another tin place which is located, taking in consideration the previous screw, as follows: above the screw there are two rows of soldering placed vertically (they are the only ones); consider the one on the right and starting counting from the bottom (front side) at the second pin there is the other tin place where to solder the other tip of the wire (it is just a bridge) you cannot fail as the two tin places are the only ones free from any soldering. However pay attention to count from the bottom otherwise if you start from the top (but there is the first pin) you find another tin place similar to the others which I don't know the effect of...

Remember to remove the mike when you activate the transponder otherwise the background noise will be transmitted.

This modification is easier to make than to explain. The transponder is activated by F + BAND and pressing again F for more than 1 second until flashing and then press low.

73 and good luck. Aldo.

This modification is read 767 times.

[top of page](#)

12-11-2000

(TM-702) Ecco una nuova modifica per il Kenwood TM702

Author: Fernando Rocca - nandorocca@hotmail.com. MODIFICATION.NET

Ho trovato che è possibile unire l'rx uhf e vhf prelevando il segnale non direttamente dai singoli discriminatori miscelato, bensì commutato dal comando Band.

Questo segnale è disponibile all'uscita del connettore dell'unità TSU-6 al pin 2 RD ovvero a fianco della massa pin 1.

Per chi non ha lo schema il connettore di cui parlo ha 10 contatti, di cui 4 a destra, 3 vuoti al centro, e 3 a sinistra. Dei 3 a sinistra RD è il secondo.

Il segnale così come è non può essere utilizzato essendo necessario disaccoppiarlo in alternata con un condensatore da 100nF; qualche modem o tnc ha già l'input disaccoppiato il mio YAM no.

Se non sono stato abbastanza chiaro sono a vostra disposizione, mi trovate in packet IS0UWS@IS0DVM in internet e-mail is0uws@libero.it. MODIFICATION.NET.

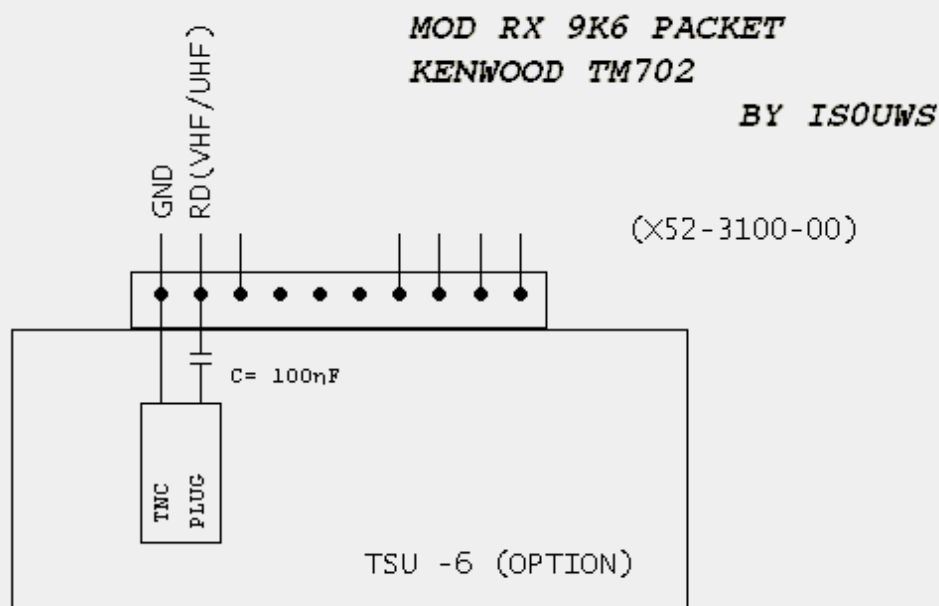

Buon lavoro e 73 de Nando IS0UWS.

is0uws@libero.it Nando 11/11/2000

This modification is read 713 times.

[top of page](#)

12-10-2001

(TM-702) Extended RX and TX for TM-702E

Author: GJ - nokia_trader@hetnet.nl. MODIFICATION.NET

For an Modification of Rx and Tx on both bands do this:

- Remove the upper case (the one with the speaker)
After you remove the case you see on the left corner (display side) a little green wire.
- Cut this wire.

After you turn your Kenwood on, it gives you RX 136-174 and 340-512 Mhz.
And also TX 136-174 and 340-512 Mhz.

This modification is read 771 times.

[top of page](#)

19-07-1998

(TM-721) Modification from Kenwood on the TM-721A for adding cross-band

To operate the TM-721A in the repeater cross-band mode, chip resistor R121 on the control unit (X53-3130-XX) (B/3), must be removed. The following modification will detail how to access the resistor.

1. Disconnect the power supply and antenna from the transceiver.
2. Remove the top and bottom covers (11 screws). Do not damage the speaker wires when removing the top cover.
3. Remove the silver colored screws from the front panel chassis (2 on each side, 1 on top, and 1 on the bottom).
4. Carefully pull the front panel away from the body of the transceiver (do not disconnect any cables).
5. Locate chip resistor R121 on the Control unit inside the front panel. Unsolder & remove the resistor.
6. If you wish to disable the built-in 3 minute time-out timer, also remove resistor R122 on the Control unit inside the front panel.
7. To place unit in repeater mode, press F key.
8. Press the A.B.C. key within 5 seconds of pressing the F key. Three dots should be lit in the main display. Unit will now operate as a cross-band repeater.

This modification is read 712 times.

[top of page](#)

19-07-1998

(TM-721) Time-out timer

The TM721A provides a built-in 3 minute time-out timer. This automatic- ally places the transceiver in the receive mode after 3 minutes of continuous transmit. This function can be defeated by removing resistor R122 on the control unit inside the front panel.

This modification is read 600 times.

[top of page](#)

19-07-1998

(TM-721) Tuning the 721 UHF for 460 MHz

Author: Edward Thomas, N2IHN

1. FIND L4 & L3 on bottom of set, turn 4 screws CCW @ 3 turns.
2. PEAK TC1, TC2, TC3 for signal strength.
3. May need to tune TC102 for transmit output and TC101 for recv.

This modification is read 681 times.

[top of page](#)

19-07-1998

(TM-721) New LCD Readout for Kenwood TM-721A

I just replaced the LCD readout on the TM-721A and thought you may be interested in my experience. The replacement is easy and gives the desired result: the readout is easy to read in high ambient light. The TM-621A can be upgraded with the same unit.

I ordered the unit from Kenwood amateur equipment division parts department which you can call at (213) 639-7140 (639-4200 and 639-9000 are alternate phone numbers I have seen on the PBBS board) and order part number B38033705, or just ask for the LCD conversion for the TM-721A. The price is \$37 plus California state tax and S&H, which came to \$43.50. They will take credit card charge over the phone.

What you get is the complete LCD display unit with its two IC drivers. On the schematic that comes with your radio you can identify the subassembly as the one labeled "LCD ASS'Y" which is connected to the control unit by an 8- conductor ribbon cable, which you must unsolder to free to old unit and resolder for the new one. The LCD subunit is attached to the control unit assembly by bent tabs which are easily undone. The ribbon cable comes with a small section of pressure-sensitive adhesive to help position it for soldering. Complete step-by-step instructions come with the unit. Installation requires a small soldering iron and is not difficult.

The results are quite good: there is no functional difference in the way the radio operates. I suspect that the new LCD is electrically identical to the old. If you have modified your radio to operate as a cross-band repeater, you retain that function. The display consists of black digits on a milky- white background. The incandescent lamps behind it operate as before, and I find that even in the "dim" mode that the legibility is good in low light. In bright sunlight, the back illumination is no longer relevant, and the readability is very good. Since bright lamp operation is not really required, they should last forever.

The old unit is not destroyed upon removal. You can return to the old readout at any time (which is prettier as it is in color). Kenwood is to be congratulated for recognizing the problem with a large installed base of TM- 721A's and making this field fix available.

While you have your radio open, you may want to activate the cross-band repeater function. Lay the CPU board down so the two ribbon cables come off to the north. A little northeast of the lithium cell, just east of the bare copper landing at the top of the board is chip resistor R121. Carefully remove it (you will probably break it). Now, you can put your radio in the cross-band repeater mode by hitting "f" "ABC". The mode is indicated by three decimal points in both main and subband frequency readouts and a signal heard on either band is retransmitted on the other. A three minute timer is in effect, which may be turned off by removing R122 (not tested). Return to normal operation by again hitting "f" "ABC". During repeater operation, all other functions are locked out. Of course, the TM-721A does not auto- identify, so it must be under direct operator control.

John, W6BM @ W6PW, in Berkeley

This modification is read 635 times.

[top of page](#)

19-07-1998

(TM-721) IC-721E RX/TX mod 142 - 152 MHz mods

The following will allow the TM-721A to transmit on the VHF band from 142.000 to 151.995mhz. Specifications are guaranteed for the Amateur bands only.

MODIFICATION PROCEDURE

1. Disconnect the antenna, mic, and power cord.
2. Remove the bottom cover from the transceiver (6 screws).
3. Locate resistor R57 on Control Unit (X53-3130-00) (A/3). The resistor can be seen by looking through the cutout of the chassis just behind the front panel. Please note that R57 is on the bottom of the unit and should not be confused with R58 on the top of the unit.
4. Using a sharp pair of wire cutters, cut the resistor lead.
5. Reinstall the bottom cover.
6. Reset the microprocessor by following the procedure on page 22 of the instruction manual entitled MICROPROCESSOR INITIALIZATION.

NOTE:

Performing the previous mod will automatically reset the processor. At least it did when I performed the mod. You can determine that when you turn the unit on and have lost all your memory settings.

NOTE:

Performing this mod does not give you the license to transmit in these newly acquired frequencies unless you have the permits.

This modification is read 639 times.

[top of page](#)

19-07-1998

(TM-721) TM-721A wide band mod

To modify the 721, remove the top & bottom covers.

Remove the 2 screws on each side that hold the front panel to the main unit.

[You can just loosen the bottom 2 screws, 1 on each side don't actually remove them.

Then remove the 2 screws in the top center & bottom center that hold the display to the main unit (all silver screws, not the black ones).

Now you can swivel the panel out & down.

Look at the back of the display unit. To the left of the Microprocessor near the lithium battery you will see 3 chip resistors in a pattern like this:

H= chip resistor

X= blank space

-----> H X H H

add a jumper (or ideally a zero ohm chip resistor where the X is.

Hold the F key while turning the radio on.

The display will go from: 100 - 200 MHz on VHF
400 - 500 MHz on UHF

WARNING!!!

Remember to write all your frequencies down before you start because you WILL lose them on both bands once you add the jumper even if you do not reset with the F key.

RELAYED BY...NOKGX...GENE

This modification is read 721 times.

[top of page](#)

19-07-1998

(TM-721) The programming resistors do the following

1. Select the European frequency bands (430 - 440)
2. Select MARS/CAP xmit freqs (141 - 150)
3. Select unrestricted out-of-band xmit (add a jumper)
4. Select cross-band repeater mod
5. Disable built-in 3 minute timeout timer for crossband repeater.

Number 1 was easy, I just installed a jumper where there were a pair of empty pads next to a row of four or five other 0 ohm (jumper) "resistors".

I found this quite useless and promptly removed it.

Number 2 is also very easy, but unnecessary for 90% of us. If you need MARS/CAP then you'll be able to get the details from Kenwood.

Number 3 is somewhat of a mystery as I've been told the jumper position but have been unable to find it on the board. My interest was in opening up the UHF receive to hear the public service channels. Unfortunately, this mod opens up transmit as well, on both bands and apparently without restriction (as the gossip goes).

Number 4 is real easy and involves removing the resistor marked R121 on the schematic.

Number 5 is also easy and just remove R122 to do it. (I haven't though)

What I'd like to know concerns the remote control capabilities that are available through the microphone plug. From looking at the manual, it's clear that when the RC-10 remote control handset is used, many of the radio's front panel controls are made remotely available. Does anybody know the manner in which the three data pins on the mike plug are used for this. The three pins are PTT, UP and DOWN (in normal mode). Presumably, there is a way to communicate with the onboard microprocessor using these pins. If so, then somebody could conceivably use their PC to control the radio.

This modification is read 615 times.

[top of page](#)

19-07-1998

(TM-721) Modifying the Kenwood TM-721A for Extended UHF Coverage

Well I finally uncovered the specifics of the mod which will extend the UHF coverage of the TM-721A. This mod changes the UHF receive from it's factory setting of 438 - 449.995 mhz to approximately 420-460 MHz. There are some peculiarities surrounding this mod so I'll describe them first.

First of all, this mod will allow the UHF digital display to traverse from 400.000 to 499.995. The radio will not, however, tune this entire range due to a combination of a limited synthesizer lock range and the input RF amplifier bandwidth. The apparent useful tuning range is about 420-460, with sensitivity dropping off sharply at either end.

Naturally, the best performance is in the middle (the Ham Band :-).

Similarly, the VHF tuning range is extended in the same manner. After the mod is made, the VHF side will apparently tune from between 100-199 mhz but as stated above, there is little or no response outside of the published range (138-170 mhz), due to the same reasons as stated above.

As a final side effect, note that performing this mod will remove all out-of-band transmit restrictions on the rig, for both VHF and UHF. After the mod is in place, the radio will transmit on any frequency that it can tune to.

DISCLAIMER:

The author of this report wishes to strongly remind those who perform this mod that it is **ILLEGAL** to transmit on any frequencies outside of the ham bands, **EVEN IF YOU ARE OTHERWISE LICENSED TO DO SO**. This is because of the radio's lack of FCC type acceptance for these frequencies. So beware! Unauthorized use of this feature could be hazardous to your ticket. MARS/CAP users are probably OK with a permit.

Now for the nuts and bolts.....

MODIFICATION PROCEDURE

1. Turn the radio on and write down all of your memory channel frequency assignments, PL codes and anything else you have in memory - It will all have to be reprogrammed after the mod. After writing down all of your data, turn off the unit and disconnect it from the antenna and power supply.
2. Next, remove the bottom cover on the unit. Note: this radio contains a number of CMOS parts which could be damaged by static discharge. Take all of the regular precautions to make sure that you and your tools are properly grounded for anti-static work. Note that there is a hole in the rear of the subchassis which supports the controller circuit board in which you can see a small, black, 1/4 watt resistor which is labeled on the board as R57. Using a small pair of sharp cutters, clip the lead on the end of the resistor. It is not necessary to remove the part, just clip one end and bend it slightly out of the way.
3. Next, remove the top cover and then open the front panel assembly into the service position. To do this, remove the four silver screws, one on the top, one on the bottom, and one from each side. Two of the screws are in slotted holes. Loosen the screws in the slotted holes slightly so as to allow the front panel to be pulled out and swung down in a hinge-like fashion. Once open, set the radio on a table with the hinged front panel hanging over the edge of your workbench. Familiarize yourself with the inside of this compartment. The most notable features are a silver, button type lithium battery to the left of center and a large, multi-pin microprocessor chip on the right. **DO NOT DISCONNECT ANY OF THE RIBBON CABLES.**
4. Locate the lithium battery and to it's left you will notice a row of five programming resistor positions, with the middle position vacant. The arrangement looks something like this:

I I:II

(Bat-)

(tery)

MPU

|

I <- R121 (remove for cross-band repeater operation)

VVV front of rig VVV

The (:) above indicates where a jumper is to be placed. Use care in soldering since everything is quite small.

5. Reassemble the unit in the reverse order as described above. When you power the rig up, the display should show 440.000 and 144.000 on the displays. It is now ready for operation. If necessary, perform the microprocessor reset function by holding down the F button while turning on the power. Reprogram the unit with the data you saved in step 1.

Comments:

There is nothing special about operating the rig once the modification is made. All functions operate exactly as before except that the range on each band is extended as described above. You will probably want to program the band scan limiting channels (A and B) on both bands since otherwise your vfo scanning will be too broad and will spend a lot of time scanning in areas which it cannot receive.

In addition, my rig also has the cross-band repeater mod. I do not know if having this is a prerequisite to performing the mod mentioned above. If it is, then R121 will also have to be removed. The cross-band repeater mod has already been discussed on the net so I won't go into it at this time.

Enjoy this mod but don't endanger your license! Don't transmit out of band and don't allow others to, even if they're licensed for those

frequencies!

This modification is read 672 times.

[top of page](#)

19-07-1998

(TM-721) TM-721A Low/No VHF Transmit Power

Author: *Trio-Kenwood Communication, inc.*

Service Bulletin no. 931 (11-4-1988)

Some early model TM-721A transceivers may develop low or no output power on the VHF band. This may be caused by coil L6 or L9 on the final unit. The coils should be inspected for burn marks on their insulation. If any flaw is detected in the insulation, replace the coil with a wider spaced coil.

Required parts:

Coil, 9.5T L6, L9 Part Number L34-1238-05

1. Disconnect the power supply and antenna from the transceiver.
2. Remove the top and bottom covers (12 screws). Do not damage the speaker wires when removing the top cover.
3. Remove the VHF Final unit shield (4 screws) from the top of the TM-721A.
4. Unsolder the Final module (Q1), antenna coax, and terminal pin W4 from the Final board.
5. Unplug the wires at connectors CN2, CN3, and CN4 on the VHF TX-RX unit (top side of the transceiver.)
6. Unplug the wires at connector CN10 on the UHF TX-RX unit (bottom side of the transceiver.)
7. Remove the 7 screws from the VHF Final unit. Remove the Final unit from the transceiver.
8. Unsolder and remove the coil (L6 or L9). Install and solder the new coil.
9. Assemble the transceiver by reversing steps 1 - 7.

This modification may be performed under warranty.
Time required for this change is 1 hour or less.

This modification is read 603 times.

[top of page](#)

19-07-1998

(TM-721) TM-721A for 9600 baud

The mods to do 9600 baud packet using a K9NG or G3RUH modem are fairly simple to do with the Kenwood TM-721/621 radios. Look at your schematic.

Receive data is taken from the discriminator output. Look for the 3.3K resistor coming off pin 9 of the last IF stage. Connect a 1K series resistor from the modem RX input to the junction of the .001 and 3.3K.

PTT is taken off pin 2 on the microphone connector. TX data is fed through a 1K series resistor to the top of VR3 (the deviation control).

This method has been tested and works quite well on 440 MHz and 220 MHz. The mods haven't fully been tested on the 2 meter portion of the radio.

The TM-731 radio is different enough to cause problems. What needs to be done is to add another RX Mute transistor. (Look at the schematic and see how the TX deviation is shorted to ground during receive.) Use a plain NPN and a pair of 10K resistors (copy the one used on VR3 in the schematic). Take the TX data and feed it to the collector through a series 1K resistor, and then feed that through another 1K resistor to the wiper of the deviation pot. This was a result of Kenwood changing the deviation pot value from 10K to 100K. (It wasn't broken, but they fixed it anyway.)

As with any modifications, take reasonable care, and I won't be responsible if you trash your radio. BE CAREFUL; it is full of surface mount devices.

This MOD file was written by Jeff, WA6FWI @ WB6YMH. #SOCA.CA.USA.NA Schematics and layouts are available by request through the author.

This modification is read 587 times.

[top of page](#)

17-07-1999

(TM-721) TM-721 cross-band repeater (another)

Chip resistor R121 on the Control Unit must be removed. Here is how.

1. Disconnect po and antenna
2. Remove top and bottom covers 2 screws)
3. Remove the silver coloured screws from the front panel chassis.
(2 on each side, 1 on p, 1 on bottom)
4. Pulfront panel away from the dio but DO NOT disconnect cables.
5. Locate chip resistor R121 on the Control Unit and desolder. When looking at the Control U, you will see the lithiuattery located to left of centre and the power switch sub-assembly located on the bottom right. Look at the centre of lithium battery a you will see R121 locatedown and to the left of the battery close to the bottom edge of the board about 3/4" left of centre of the battery. Remove ts chip resistor.
6. re is also a 3 minute timut timer that will place the radio into the receive mode after 3 minutes of continuous transmit. I removed mine and I willescribe the location of R1 which defeats the timer. If you look again at the lithium battery, look at the bottom edge of e battery and then over tohe right about 1 inch from the bottom centre of the battery and you will come across an upper set of 2 resistors and below that another set of 5 resistors (chip type). Remove the first resistor (left one) in the upper set.

OPERATION

Repeater cross-band operation allows the 721 to receive on one band and retransmit the signal on the other band. An incoming signal will automatically be switched to the subband. The 721 will then re transmit the signal from the main band. Each band may contain offset and subaudible tone information with the tsu-6 tone board.

The encode and decode tones for a single band must be the same. Each band may contain a separate sub-audible tone frequency.

1. Select the first frequency in the main band and select a repeater offset if desired.
2. Select TONE if needed.
3. Press the BAND key to transfer contents of MAIN into SUB.
4. Select the second frequency and if desired a CTCSS tone.
5. Adjust the main and sub band squelches to the threshold.

ENABLING CROSS BAND REPEATER

1. Press the F (orange function) key
2. Press the A.B.C. key within 5 seconds of step 1 Three dots will light in the decimal place locations in the MAIN band.

The repeater will always transmit out of the main band. I will give you an example of accessing a 70cm repeater with a 2m handheld on a simplex freq.

Desired repeater RX 444.8 TX 449.8 2m 145.54

In main band enter 145.54 and press BAND key to transfer to sub display. Enter 444.8 with + offset. Press F + A.B.C.

Key up simplex handheld and you will see the sub-band receive your frequency and at the same time you will see the main band key up and transmit on 449.8 Mhz.

Release the simplex PTT on the handheld and the radio will quickly flip 145.54 into the MAIN band and 444.8 into the sub-band. The 70cm repeater will be transmitting to your radio in the sub-band at 444.8 and the 721 will be transmitting out of the MAIN band on 154.54.

Neat stuff !!!! Warning, disconnect your mic or be quiet and DOUBLE WARNING DO NOT PUT A 2M repeater in the MAIN and a 70CM in the sub or they will continually key up each other back and forththrough the 721. Also notthat when the 721 is transtting on the MAIN band ouo your 2M simplex radio and receiving a signal from the 70cm repeater, you will not be able to gain control of the transmitter of your 721 until the 70 cm tail drops as the radio does not sample the incoming audio for a carrier while transmitting.

The mod is neat and if you disable the tail timer on your 70 cm repeater, this works great in situations where a hand held (1 watt) cannot access the 2M repeater.

Author: Trio-Kenwood Communication, inc.

Service Bulletin no. 930 (11-4-1988)

Some early model TM-721A transceiver may malfunction when nearby transmissions (such as operating a handheld too close to the unit) enter the microprocessor reset circuit. As the RF energy enters the circuit, the microprocessor ceases to function which results in shutting off the sub-display, receiver, and transmitter. Adding a capacitor to the base of the reset switching transistor on the control unit will correct the condition. The following procedure will detail how to access the transistor.

Required parts:

C124 1000pF 50V chip capacitor (CK73FB1H102K)

1. Disconnect the power supply and antenna from the transceiver.
2. Pull the Volume, Main squelch, and Main tuning knobs from the front panel.
3. Remove the top and bottom covers (12 screws). Do not damage the speaker wire when removing the top cover.
4. Remove the silver colored screws from the front panel chassis (2 on each side, 1 on top, and 1 on the bottom).
5. Carefully pull the front panel assembly cut from the body of the transceiver (do not disconnect any cables).
6. Remove the 2 brass colored screws from the top of the plastic front panel.
7. Lift the 2 tabs on the bottom of the front panel and pull the panel off the assembly. Do not loose the black shades positioned over the Balance and Sub-squelch switches. Keep the switch assembly intact ad much as possible.
8. Straighten the display unit mounting clips and pull the display unit from the control board (do not disconnect the cable).
9. Locate Q102 on the top right hand side of the control board (next to the volume control).
10. Add a 1000pF chip capacitor between the base of Q102 and ground (the capacitor will physically be mounted between C123 and R141).
11. Assemble the transceiver by reversing the steps above.

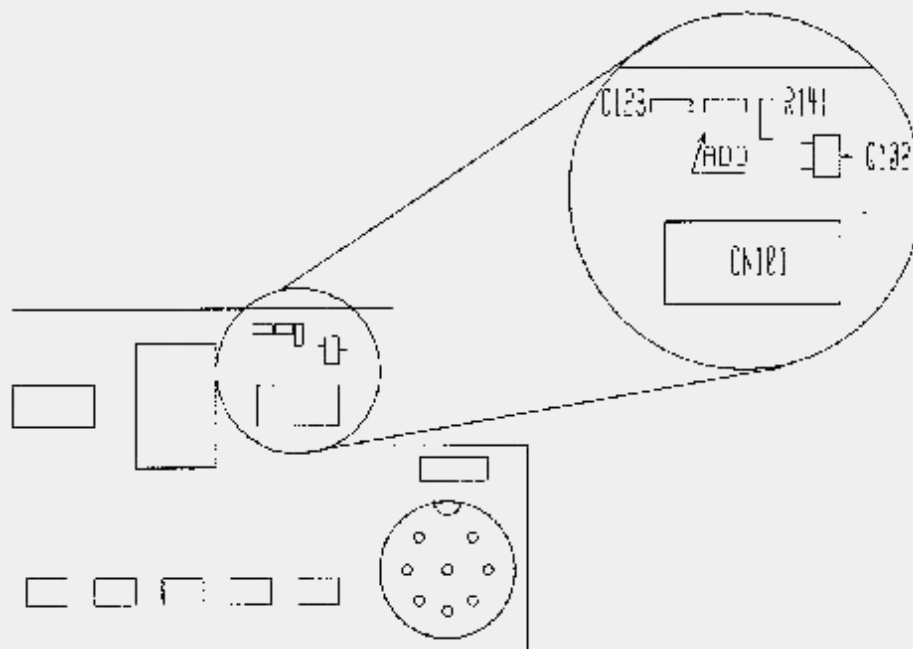

This modification may be covered under warranty.
Time required for this modification is 1.5 hour or less.

Author: Trio-Kenwood Communication, inc.

Service Bulletin no. 936 (2-6-1988)

When the TM-721 is operated mobile, strong ignition noise generated by motorcycles may cause the S-meter to deflect on the VHF band. The ignition noise cannot be mistaken for a signal because the busy light does not come on, but the S-meter deflection may be distracting. The following modification will prevent this occurrence.

Parts required:

10 pF, 50 V chip capacitor	CC41FCH1A100D
0.47 μ F, 25 V chip capacitor	C92-0003-05

1. Disconnect the power supply and antenna from the transceiver.
2. Remove the top cover. Disconnect the speaker wires.
3. Unplug all connectors on the TX-RX (VHF) unit. Remove the 7 screws securing the board to the transceiver and then remove the board from the transceiver.
4. Desolder and remove C39 from the bottom of the board. Install and solder a 10 pF capacitor in place of C39 (Figure 1).
5. Add a 0.47 μ F capacitor from the junction of R39 and D11 to ground (Figure 1). Install the TX-RX unit.

S-Meter alignment

1. Apply power to the transceiver.
2. Set the transceiver to receive at 146.040 MHz.
3. Inject a $-1\text{dB}\mu$ ($0.45\mu\text{V}$) signal into the VHF antenna connector.
4. Adjust VR2 on the TX-RX (VHF) unit to obtain an S-1 indication on the display.
5. Increase the input signal to $30\text{dB}\mu$ ($15.8\mu\text{V}$) and verify that all the LED's light.
6. Disconnect the signal generator. Turn the transceiver off. Install the top cover (don't forget to plug in the speaker).

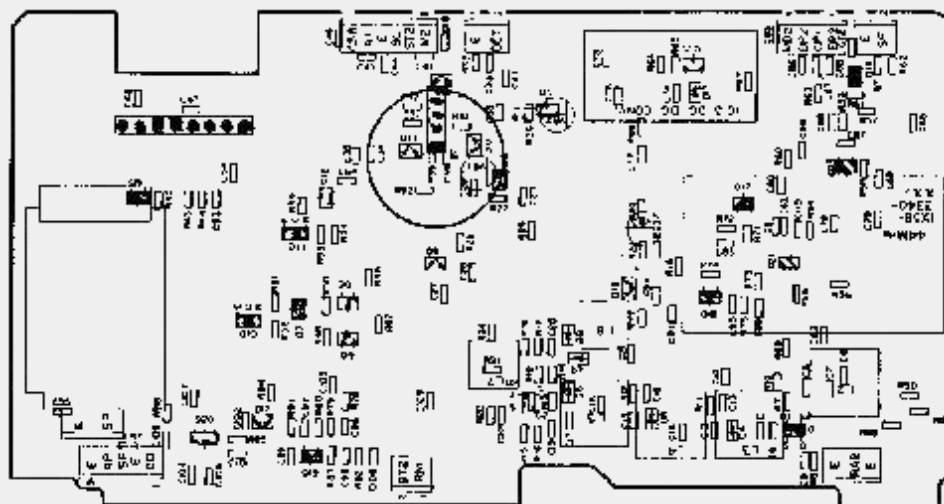

This modification may not be covered under warranty.
Time required for this modification is 1 hour or less.

Author: Trio-Kenwood Communication, inc.

Service Bulletin no. 937 (2-6-1988)

Some users of the TM-721A may detect white noise from the speaker with the squelch turned on. The noise can be reduced by lowering the gain of the Audio Frequency Power Amplifier. To compensate for the reduction, the gain of the pre-amplifiers will be increased. In addition, the beep level will be raised.

Required parts:

12 Kohm 1/10 watt chip resistor	RK73FB2A123J
18 Kohm 1/10 watt chip resistor	RK73FB2A183J

1. Disconnect the power supply and antenna from the transceiver.
2. Remove the top and bottom covers (12 screws). Do not damage the speaker wires when removing the top cover.
3. Unplug all connectors from the TX-RX (VHF) unit on the bottom of the transceiver. Remove the 7 screws from the board and then pull the board from the transceiver.
4. Unplug all connectors from the TX-RX (UHF) unit on the bottom of the transceiver. Remove the 6 screws from the board and then pull the board from the transceiver.
5. Remove the silver colored screws from the front panel chassis (2 on each side, 1 on top, and 1 on the bottom).
6. Pull the front panel assembly away from the body of the transceiver (do not disconnect any cables).
7. Remove the 6 screws from the Control unit (A/3) which is mounted on the body of the transceiver.
8. Pull the board away from the transceiver, but do not disconnect the red and black wires. Keep track of the two short coax cables that run under the Control unit. The cables connect between both TX-RX units.
9. On the component side of the Control board (the side with the majority of connectors) replace R7 with an 18 Kohm chip resistor (figure 1).
10. Assemble the front panel by reversing step 5 - 8. Do not forget to run the two short coax cables (mentioned in step 8) under the Control unit.
11. On the foil side of the TX-RX (UHF) unit, remove chip resistors R37 and R41 (Figure 2).
12. On the foil side of the TX-RX (VHF) unit, replace R43 with a 12 Kohm chip resistor (figure 3).
13. Assemble the transceiver by reversing step 1 - 4.

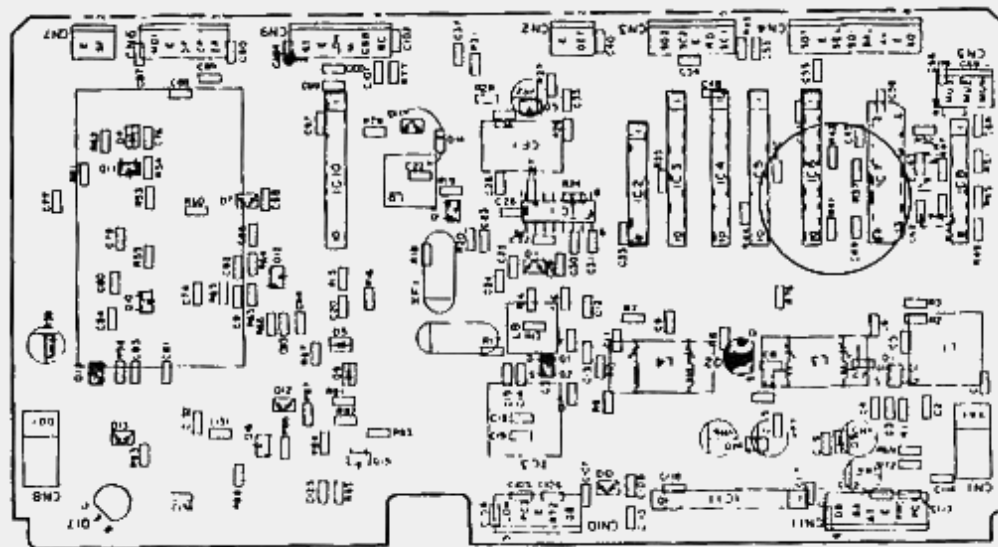

TX-RX (UHF) UNIT

FIGURE 2

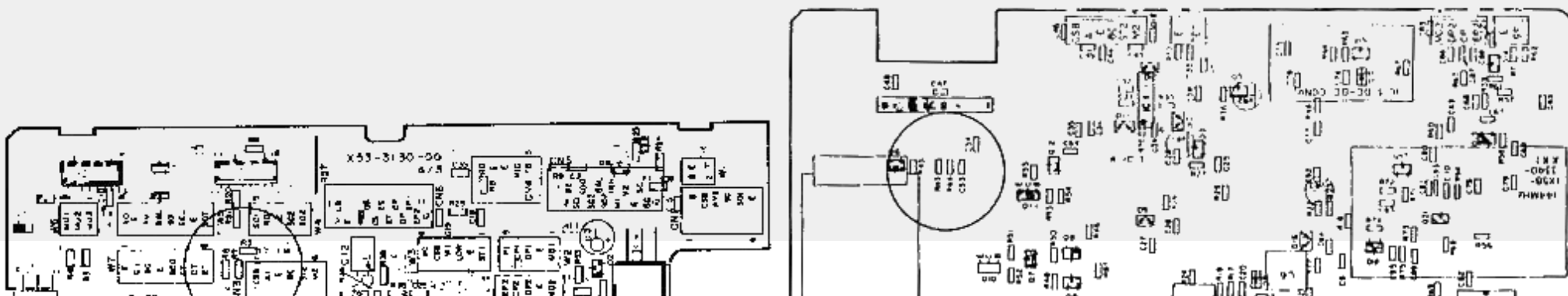

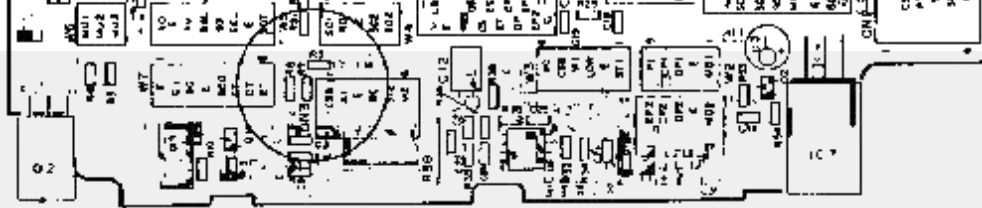

CONTROL UNIT

FIGURE 1



TX-RX (VHF) UNIT

FIGURE 3

This modification may not be covered under warranty.
Time required for this modification is 1.5 hour or less.

This modification is read 573 times.

[top of page](#)

19-07-1998

(TM-731) TM-731 frequency and cross band repeater

The TM-731a will transceive between 136-174 MHz and 400-500 MHz as well as perform cross band repeater function when the following modifications are performed.

1. Remove both the top and bottom cover. Disassemble the front panel such that the control unit (X53-3250-XX) is accessible.
2. Remove R121, R123 and R25. While R125 and R124 must be present.
3. If the time-out timer function is not desired, remove R122 as well.
4. Reassemble the unit and perform a microprocessor reset before operating the set.
5. Preserve your license by operating within the bands it is cover for.

This modification is read 1097 times.

[top of page](#)

19-07-1998

(TM-731) TM731 & 9600 Bps

The TM731 is different enough to cause problems.

What need to be done is to add another RX Mute transistor. (look the schematics and see how the TX deviation is shorted to ground during receive.)

Use a plain NPN and a pair of 10k resistor (copy the one used on VR3 in the schematics.)

Take the TX DATA and feed it to the collector through a series 1k resistor, and then feed that through another 1k resistor to the wiper on the deviator pot.

This was a result of Kenwood changing the deviation pot value from 10k to 100k (it's wasn't broken, but they fixed it anyway.) It is full of surface mount devices.

Article of Jeff WA6FWI @ WB6YMH. #SOCA.CA

From: CQ USA - June/92

This modification is read 829 times.

[top of page](#)

19-07-1998

(TM-731) TM-731 fuer 9600 Baud

de DG5EM @ DB0IZ

Umbaumaassnahmen beim TM 731 von Kenwood zum betrieb mit G3RUH-Modem 9600 Baud

Das Geraet von der Seite oben die Platte abschrauben, wo sich auf dem rueckseitigen Kuehlkoerper die Blindbuchse mit Stopfen befindet.

Kontrollieren ob man wirklich die 430er-UNIT vor sich hat hi.

Diesen Stopfen entfernen und das Loch als Eingang fuer das 4-Ader abgeschirmte Tonkabel benutzen. (Zugentlastung nicht vergessen!) Von dem Einbau einer Klinkenbuchse oder aehnlichen rate ich ab, besser ist es aussen eine Steckverbindung vorzusehen, um den TRX vom Modem zu trennen.

Sollte sich das Tonkabel nun im TRX befinden und die Adern sind abisoliert, kann der Loetkolben angeschmissen werden.

Die Leitung RX-Audio vom G3RUH-Modem an Pin 9 von IC3 (MC3361/SMD) loeten. (feine Spitze ist beim Loetkolben angesagt).

Nun schaut man auf eine 4polige Steckerleiste, die im Schaltplan als Nr.12 angegeben ist. Die vierte Ader davon hat die Bezeichnung MDI.

Sie verbindet den Mikrofonverstaerker-Ausgang mit dem Hubpoti VR3. Diese Ader wird jetzt aufgetrennt und ein 12V-Reed-Relais Oeffner- Kontakt dazwischen gesetzt. (Das anbringen des Relais muss jeder selber austueffeln da in erster Linie von der Bauform abhaengig) An der Relaispule nun eine der restlichen 3 Adern des Tonkabels anloeten ,spaeter wird ueber diese Ader 12V vom Modem kommend herangefuehrt. Also...Modem eingeschaltet = Paket

Modem ausgeschaltet = Phonie

Die Leitung TX-Audio vom G3RUH-Modem an das heisse Ende loeten, also in Richtung dem Hubpoti VR3 gesehen.

auf KEINEM Fall am Hubpoti im TRX eine Einstellung vornehmen!

Der Hub wird ausschliesslich am G3RUH-Modem bestimmt.

Das anloeten der letzten verbliebenen Ader, der PTT-Leitung, ist schon etwas umstaendlicher. Schliesslich muss man irgendwie an die Mikrofonbuchse von hinter her dran.

Wer nicht die Lust hat alles weiter zu zerlegen, kann auch wie bisher die PTT vorne per Stecker anschliessen.

Von innen her ist es allerdings eleganter, da das Mikro dranbleiben kann und die laestige umstoepselei umgangen wird.

An dieser Stelle sei dringend erwaehnt, das nur gutes Tonkabel verwendung finden sollte, mit DICHTER Abschirmung. Eine gute Kontaktgabe mit der Geraetemasse ist entscheidend fuer ein sauberes Sende-und Empfangssignal.

HINWEISE:

Mikmiken wie das einfuegen von einem zusaetzlichen Relais fuer ZU - und ABSchalten der Sende-NF sind NICHT noetig und auch garnicht wuensenswert. Das TXD wuerde doch negativ darunter leiden. Die NF-Abschaltung uebernimmt der spezielle Schalttransistor Q18.

Er ist in der Lage im Empfangsfall die Sende-NF vom G3RUH sicher zu unterdruecken (nach Masse zu ziehen).

Ansonsten waere es auch garnicht moeglich ein empfangenes Signal richtig zu decodieren (gaebe nur Mischprodukte).

Der 455khz-Filter CF1, brauchte bisher nie gegen einen breiteren getauscht werden.

Zum Abgleich ist nur zu erwaehnen, das der Sende-NF-Hub vom Modem so klein als moeglich gehalten wird. Das kommt der PLL sehr zu gute (Regelneigung ist kleiner) und schon das Bandraaster.

Als Faustformel hat sich erwiesen das der Hub "gut" ist, wenn er sich mit dem Grundrauschen auf einer Ebene befindet.

Kann mit 2ten TRX oder Hilfe von einem anderen OM schnell eingestellt werden.

TXD unter 11 ist moeglich und sollte auch !darunter! betrieben werden, da bei einem 96er-Einstieg ein zu hohes TXD die Suppe versalzen kann.

Schwierigkeiten sind nur bekannt geworden bei betrieb ueber einen Duplex-Digi. Manche Exemplare rasten wohl bei grosser QRG-Aenderung nicht rechtzeitig ein und HOEREN dadurch extrem zu SPAET!

Ich habe diese Anleitung jetzt mal veroeffentlicht, da nun genug Erfahrung mit diesem PLL-Mobil-TRX in bezug auf 9600bd gemacht sind.

Als Abschluss moechte ich dennoch ausdruecklich betonen, das die Verwendung von PLL-Geraeten NICHT auf Dauer zu empfehlen ist. Es ist nur eine Frage der Zeit bis die neueren Digi,s (96er sind gemeint) auf wesentliche schnellere Parameter eingestellt werden.

Ich selber benutze einen IC475E von Icom, der fast wie geschaffen ist fuer diesen betrieb (ueber diesen TRX hab ich schonmal was veroeffentlicht).

vermutlich sind mir bei dieser Beschreibung ein paar Fehler unterlaufen (oder doch diesesmal nicht)?

Fragen zu diesem Thema und Erfolgsmeldungen bitte zu richten an
DG5EM , Helmut @ DB0IZ

This modification is read 765 times.

[top of page](#)

19-07-1998

(TM-731) TM-731A Hooking to TNCS

Home packet BBS: WD6CMU Richmond, Northern CA

I recently acquired both a PK88 TNC and a Kenwood 731a dual band mobile transceiver. I wanted to hook the Kenwood to the PK88. What I found was that the audio output on pin 6 of the eight pin microphone connector on the front panel was not the same as the audio that comes out of the speaker or out of the rear speaker connector.

What you get out the audio from the front panel mic connector on pin 6 is an UNSQUELCHED audio. Kenwood does this, apparently, to support their RC10 remote controller for the unit, to allow the RC10 independent control over the squelch on the audio at the RC10's speaker. This causes a problem, for when you feed that into the audio input of the PK88, its DCD light stays on ALL THE TIME. The PK88 will receive data just fine when hooked to pin 6 of the TM731a mike connector, but it will refuse to key the transmitter because it perpetually thinks the air is "busy".

The simple approach to hooking the PK232 to the Kenwood involves using a separate cable with a 1/8 in mini phono plug at each end, and run that between the audio phono connector on the PK88 and the speaker output jack for "main audio" on the TM731a. This will allow packet operation, and is no doubt the approach that virtually everyone uses. There are some drawbacks to this arrangement, tho.

Using two cables is a tad clumsy. Worse, when you plug in the cable in the rear speaker connector, there is no way to enable the speaker to audibly check your signal. It also makes it impossible to make a switch box to switch the TM731a from packet to audio operation at the flick of a switch, for as long as the phono plug is plugged into the back of the TM731a, you CAN NOT enable its internal speaker. Finally, this arrangement requires you to adjust the volume control to the right level and leave it there.

What follows is a mod that give you a SQUELCHED, LINE LEVEL audio signal available on pin 6 of the microphone connector. With such an arrangement, you can turn your speaker volume up and down as you like, and it will not affect the audio going to the packet box. You can use a single cable to connect the packet box to the transceiver, and it is easy to rig up a switch box that switches between the packet box and the hand microphone. The only disadvantage of doing this mod is that your TM731a will NO LONGER be compatible with the RC10 remote control device.

The Modification:

This modification requires skill at fine soldering, a good ultra fine-tipped pencil type soldering iron, and a short piece of 28 gauge stranded wire. You really should have at hand a Kenwood service manual for this rig, with complete schematic and board layout diagrams, before you attempt it, tho I HAVE tried to write my description so that you can do the mod without a service manual at hand.

1. Turn off power and disconnect the rig from its source of power
2. Remove the BOTTOM cover of the rig.
3. Lay the rig on your work table with the front panel pointing away from you, and its rear heat sink pointing toward you. On the right will be the main volume and squelch control. Look at the little connectors that hook the front panel of the radio to the board you have exposed and are looking at. On the extreme left is one connector with eight pins in a row, with the third pin from the left unused. To the right of that is a five pin connector with the middle pin not used. To the right of that connector is an electrolytic capacitor, to the right of the cap is a two pin connector, and to the right of the two pin connector is a phillips screw that is one of the screws that hold the board you are looking at inside the rig.

Locate that five pin connector mentioned above, the one that has its middle pin unused. The SECOND WIRE from the LEFT of that connector should be a RED wire. That spot on the connector will be labelled on the main board you are looking at as "RDM".

4. CUT this red wire about three quarters of an inch from where it leaves the connector. Tape up the portion that goes to the connector.
5. Strip off about a quarter inch of insulation from the portion of the red wire that dives into the rig and heads toward the front panel.
6. Locate "IC 8" on the radio. This is actually NOT a real integrated circuit, but rather is one of six little vertical circuit boards that jut up like fins from the main board. IC 8 is the left most of the six such boards, and is right next to IC 9, which is a zig zag in line pin integrated circuit. IC 8 is located just toward you from the five pin connector with the four wires... the one from which you cut the red wire. IC 8 is labelled as "IC 8" in silk screening on the circuit board.
7. Solder a short length (2 or three inches) of stranded, insulated, 28 gauge wire to pin 9 of IC 8. Pin 9 of IC 8 is the next to last pin of this single in line pin "IC". The "last" pin of IC 8, or pin 10, is located closest to the rear of the rig (closest to you, given the orientation of the rig that I suggested).
8. Now solder the other end of this wire to the stripped, cut portion of the red wire that you prepared in step 5 above.

That's it! you now have modified your rig to provide line level, squelched audio on pin 6 of the microphone connector.

For those technically inclined, you should note that this audio is leaving an audio amplifier, and going thru both a 1K ohm resistor and a .1 mfd capacitor before it arrives on pin 6 of the microphone connector. Thus the signal is DC-blocked and reasonably protected against minor nastiness that might appear on pin 6.

I'd appreciate any feedback from those attempting this modification, tho of course I must note I cannot take responsibility for any harm that may come to your radio due to either proper or improper implimentation of this modification. I CAN say honestly that I HAVE done this to my radio, and it appears to work quite well.

19-07-1998**(TM-731) Kenwood Cross Band Repeat: How to USE it**

Hardware information for modifying the Kenwood TM-731A for cross band repeat is widely available on many packet bulletin boards. However, information on how to impliment cross band repeat is often not present along with the description of the hardware mods. What follows is KENWOOD's documentation on how to USE the TM731a after it has been modified for cross band repeat:

Text of Kenwood Sheet on using Cross Band Repeat on the TM-731A:

The repeater corss-band operation allows the TM-731A to receive on one band and re-tramsmit the signal on the other band. An incoming signal will automatically be switched to the sub-band. The TM731A will then re-transmit the signal from the main band. Each band may contain shift information. Only one band can contain sub audible tone information (the optional TSU-6 ... currently called by Kenwood the KQT8... is required for tone decode). If one band requires a sub-audible tone, either select the TONE function for encode or the CTCSS function for encode / decode. DO NOT turn both TONE and CTCSS on in the one band.

1. Select the first frequency in the main band. If required, select the offset.
2. Press the BAND key to move the contents of the main display to the sub-display.
3. Now select the second frequency and offset.
4. If Tone or CTCSS is required for one of the bands, continue with this step. If Tone or CTCSS is not required, go to step 5.
 1. Place the operating frequency that requirs TONE or CTCSS in the main band (use the BAND key).
 2. Select the sub-audible tone by pressing the F key and then the T.SEL key. Rotate the main encoder knob until the desired tone is displayed. Press any front panel key to display the operating frequency.
 3. If only the TONE function is required, press the TONE key (the [T] indicator will light in the display).
 4. If the CTCSS function is required, do not turn the TONE function on. Instead, press the F key and then the CTCSS key (the [CTCSS] indicator will light in the display. If the CTCSS arrow is not pointing towards the main display, press the F key and then press the CTCSS SEL key.
5. Adjust the main and sub-band squelch controls to the threshold point. The TM-731A will transmit in the repeater cross band mode if the squelch controls are set too low or a signal is received. (comment: setting both squelch controls properly is VERY important!)
6. Note:
The next step will place the unit in the repeater cross-band mode

Press the F key and then press the A.B.C. key. Three dots should be lit in both display frequencies. The unit will now operate as a cross band repeater as described above.
7. To take the TM-731A out of the cross-band repeat mode, repeat step 6.

19-07-1998**(TM-731) Kenwood TM-731A firmware bug**

The Kenwood TM731A dual bander has a firmware bug that breaks the 2m VFO scanner in certain circumstances, that is, the 2m VFO scanner won't work properly if certain PL tones are stored into memory 1. So far, all tested 731A's have had this problem. The highest serial number tested was 72713. To demonstrate the problem, perform this experiment:

1. If not already done, load search bounds into memories A and B of the 2m unit. Verify that the VFO scanner works.
2. Change the PL tone for memory 1 to (for example) 91.5: select memory 1, press F VFO to transfer it to the VFO, then press F TSEL and select 91.5 Hz PL tone, then store back into memory 1 by pressing F MR.
3. Set the VFO to a frequency outside the range given in memories A and B, then start the VFO scanning (by pressing VFO for a few seconds).
4. If your radio has the bug, it will alternate between the frequencies stored in memories A and B. If you start the scan while the VFO is within the search range, it will scan up until the top limit is reached, then begin alternating between the two limit frequencies.
5. To restore 2m VFO scanning, program memory 1 with one of the several PL tones acceptable ... the default of 88.5 Hz works fine.
6. The 70cm unit does not appear to have this problem.

21-04-2000**(TM-731) TM-631/731A Memory loss modification****Author:** Kenwood Communication, inc.

Service Bulletin no. 972 (8-8-1990)

Some TM-631/731A owners have reported that the transceiver intermittently loses its memory channel information when the power switch is turned on. The following modification will absorb pulses on the CPU interrupt line (INT4) and reconfigure the backup switching circuit to avoid unintentional memory loss.

Read all instructions before proceeding. Do not attempt this modification if it is beyond your capability.

Required parts: ZKIT-731MEMO

The kit contains:

Part #	Description	QTY.
NJM78L06A	6 V AVR	1
1SS133	Diode	1
MTZ3.0JB	3.0 V Zener diode	1
CE04NW0J221M	220 μ F, 6.3 V Electrolytic capacitor	1
C91-0457-05	0.022 μ F ceramic capacitor	1
CK45B1H103K	0.01 μ F ceramic capacitor	1
RD14BB2C103J	10 Kohm, 1/6 watt resistor	1
RD14BB2C102J	1 Kohm, 1/6 watt resistor	1
RD14BB2C472J	4.7 Kohm, 1/6 watt resistor	1
RD73FB2A472J	4.7 Kohm, 1/10 watt resistor	2

1. Disconnect the power supply, antenna, and microphone.
2. Remove the top and bottom covers (12 screws). Do not damage the speaker wires when removing the top cover.
3. Pull the Main Encode, Volume, and Main Squelch knobs off the front panel. If a knob does not easily pull off, wrap a cloth around the knob and carefully pull it off with a pair of pliers. Be careful not to crush or scar the knob.
4. Remove the two brass colored screws from the top of the plastic front panel. Figure 1.
5. Gently lift the two tabs on the bottom of the front panel and then pull the front panel off the transceiver. Figure 2.
6. Remove the two black shades from the Balance and Sub-Squelch controls. Figure 3.
7. Remove the three brass colored screws from Control board B/3. Figure 3.
8. Remove the brass colored screw that is mounted on the front panel chassis above the Power switch. Figure 4.
9. Remove the brass colored screw that is mounted on the front panel chassis to the right of the microphone jack. Figure 4.
10. Carefully pull Control board (B/3) away from the body of the transceiver.
11. Disconnect the two "wire type" cables from the body of the transceiver.
12. Disconnect the two flex cables from the Control board. The flex cables simply pull out of the connectors.
13. Remove IC102 from the Control board. Since this device is glued to the board, use a needle tip tool to lift each pin as you melt the solder. Then pry the chip off the board with a craft knife. Figure 6.
14. Remove any excess glue and solder from the area where IC102 was located.
15. Remove chip resistor R103. Do not melt connector CN101. Figure 6.
16. Cut the foil pattern between connector CN101 and chip capacitor C102. Make the cut as close to connector CN101 as possible. Figure 6.
17. Prepare the 1SS133 diode for installation. The cathode lead will be cut and bent 90°. The diode must lay flat on the board and the cathode lead cannot touch the cut in foil. Once the diode leads are prepared, solder the diode in place. Figure 7.
18. Prepare the NJM78L06A 6 V AVR for installation as shown in figure 8. The leads to this device are vary soft and can break when bent too often. Make each bend only once.

19. The 6 V AVR will be mounted in place where IC102 was located. The board must first be prepared for the installation. Remove the protective coating from the foils as shown in Figure 7. These are the foils that were connected to pins 2 and 7 of IC102 and the ground foil that runs under the device.
20. Place the 6 V AVR on the board and make sure the leads contact the foils. Cut the leads to size and then solder the device to the board. Figure 9.
21. Prepare the 0.01 μ F capacitor, 10 Kohm resistor, and 4.7 Kohm resistor for installation. Place the parts on the board to size and cut the leads. Once the parts are prepared, solder them to the board. Figure 10.
22. Locate R105. If the component is 47 Kohm, change it to a 4.7 Kohm chip resistor. The component's value can be determined by the numbers written on the case. If the device is labeled 473, it is a 47 Kohm resistor and needs to be replaced. If the device is labeled 472, it is a 4.7 Kohm resistor and does not need to be replaced. Figure 10.
23. Straighten the tabs that hold the LCD assembly to the Control board. Carefully pull the LCD assembly off the Control board (do not break the flex cable). Figure 5.
24. Remove C123. This chip capacitor is located in the corner of the board under the LCD assembly. Figure 11.
25. Remove the protective coating from the foils as shown in figure 11.
26. Place the 3.0V zener diode on the board. Size and cut the diode's cathode lead. Solder the lead to the board. Figure 12.
27. Place the 1K ohm resistor on the board. The body of the resistor must be parallel to the diode. Size and cut the resistor's left hand lead. Solder the lead to the board. Figure 12.
28. Bend the diode's anode lead and solder it to the resistor's right hand lead. Do not allow the leads to touch the board. Trim the leads after soldering. Figure 12.
29. Prepare the 0.22 μ F capacitor for installation. Place the component on the board to size and cut the leads. Figure 12.
30. Solder the left hand lead to the junction of the zener diode and 1 K ohm resistor. Do not let the connection touch the board. Figure 12.
31. Solder the right hand lead to the board as shown. Figure 12.
32. Replace C107 with the 220 μ F electrolytic. C107 is located between the Main and Sub rotary endoders. Figure 3.
33. Mount the LCD assembly on the Control board and bend the four tabs to hold it in place. Make sure the LCD does not touch the leads of the new parts.
34. Connect the two flex cables to the Control board and then plug the two "wire type" connectors into the body of the transceiver.
35. Mount the Control board on the body of the transceiver and secure it with the three brass colored screws that go through the Control board. Be careful not to pinch any wires.
36. Install the brass colored screw that goes above the power switch and install the brass colored screw that goes to the right of the microphone jack.
37. Install the two black shades on the Balance and Sub-Squelch controls.
38. Slide the lock, balance, and Sub-Squelch controls to the left.
39. Slide the Lock, Balance, and Sub-Squelch knobs on the plastic front panel to the left.
40. Gently install the plastic front panel on the front panel assembly. Do not force the installation.
41. Install the two brass colored screws on the top of the plastic front panel.
42. Install the Main Encode, Volume, and Main Squelch knobs.
43. Remove the two screws from the small board where the positive power lead connects on the bottom of the transceiver.
44. Solder the remaining 4.7 Kohm chip resistor to the foil side of the board. Figure 13.
45. Mount the board and install the covers on the transceiver.

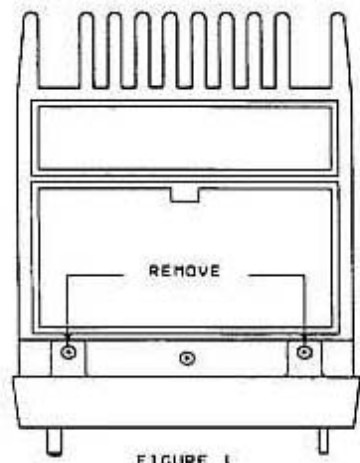

FIGURE 1

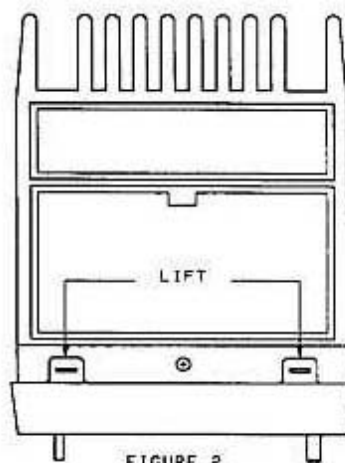

FIGURE 2

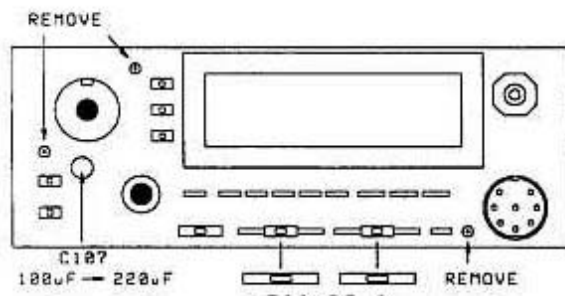

FIGURE 3

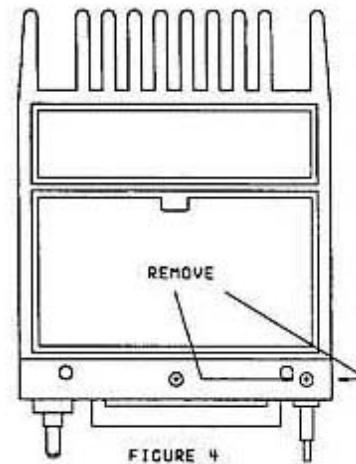

FIGURE 4

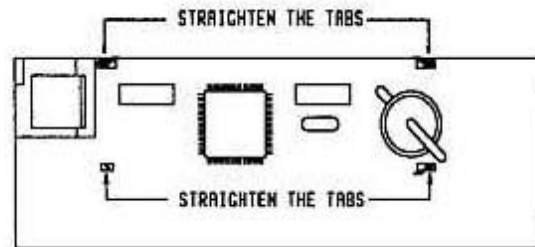

FIGURE 5

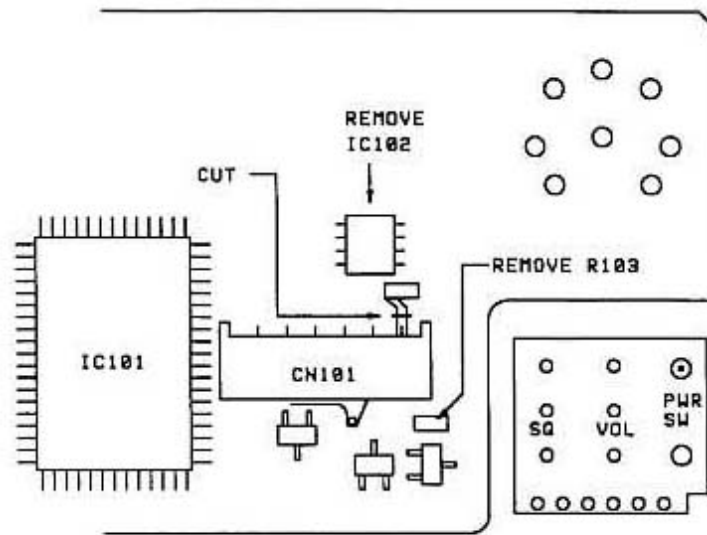

FIGURE 6

REMOVE PROTECTIVE COATING

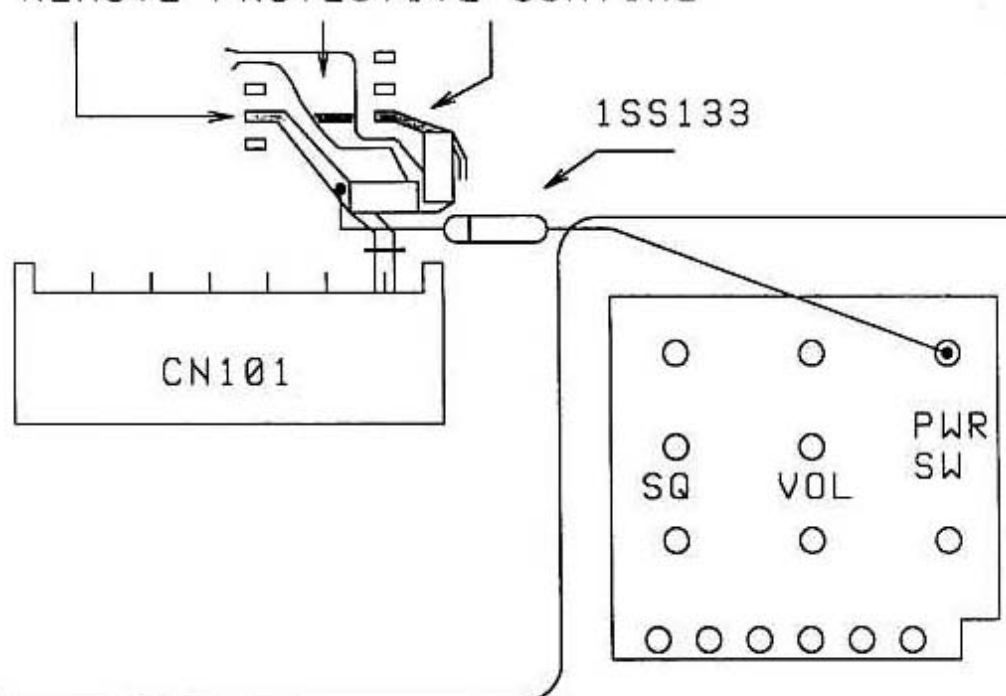

FIGURE 7

FIGURE 7

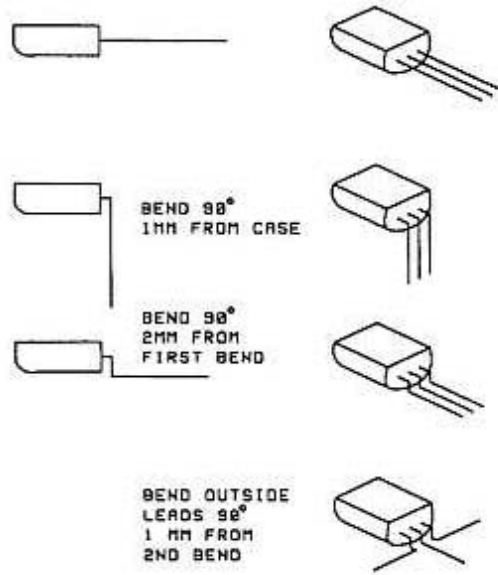

FIGURE 8

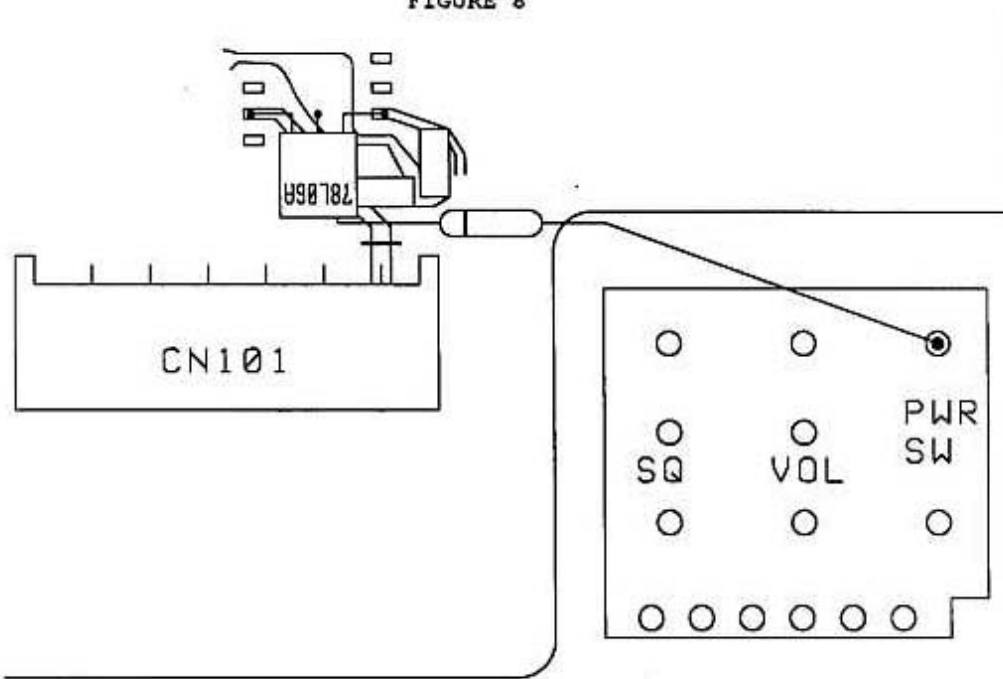

FIGURE 9

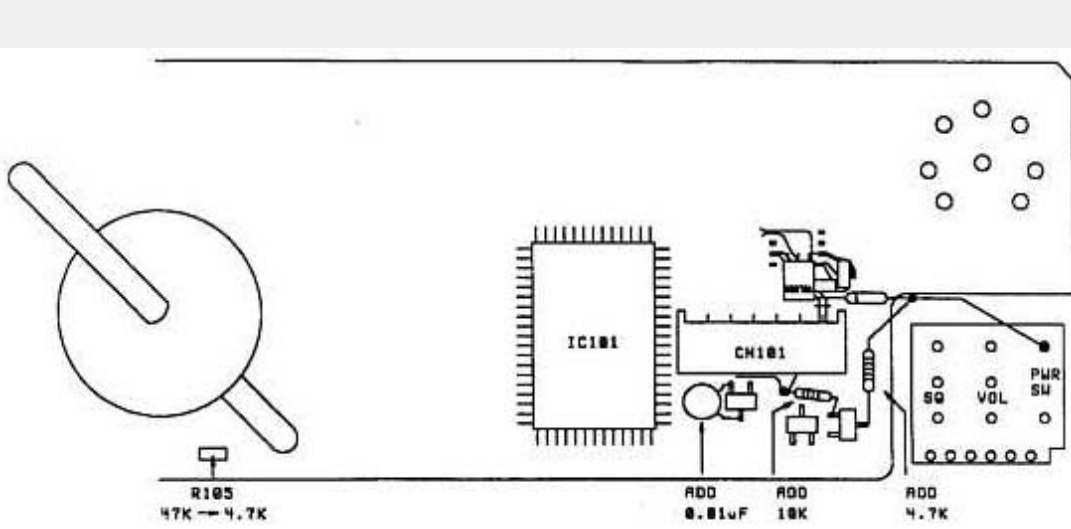

FIGURE 10

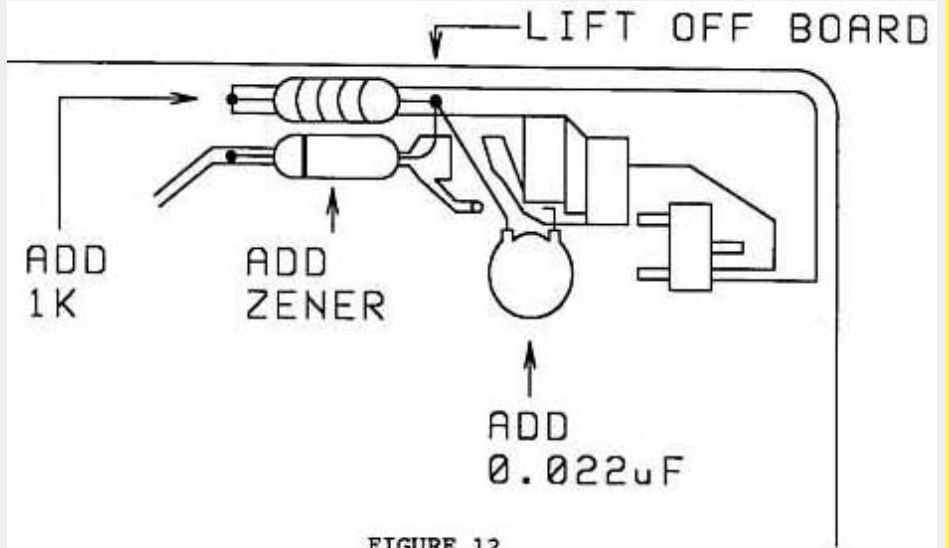
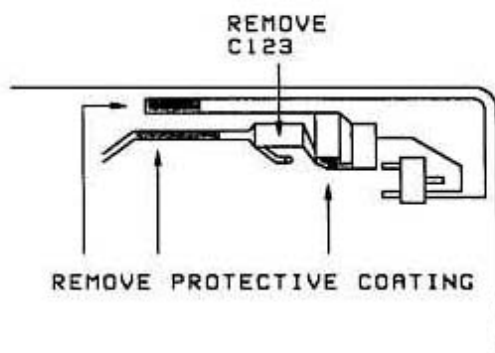
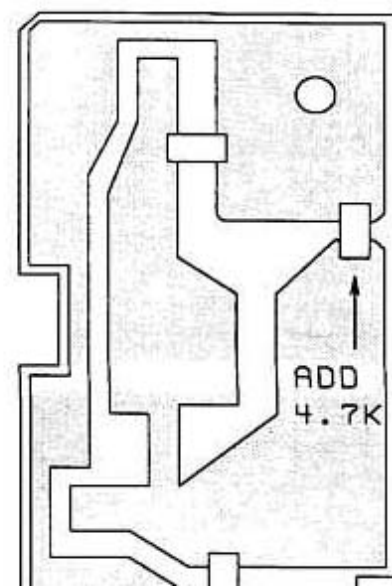

FIGURE 12



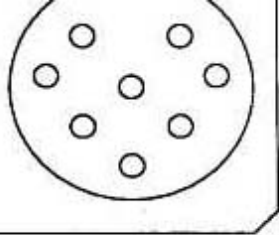

FIGURE 11

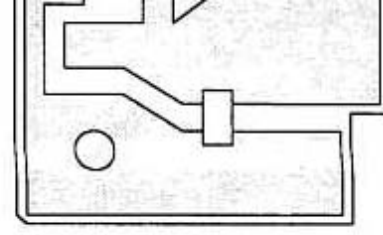
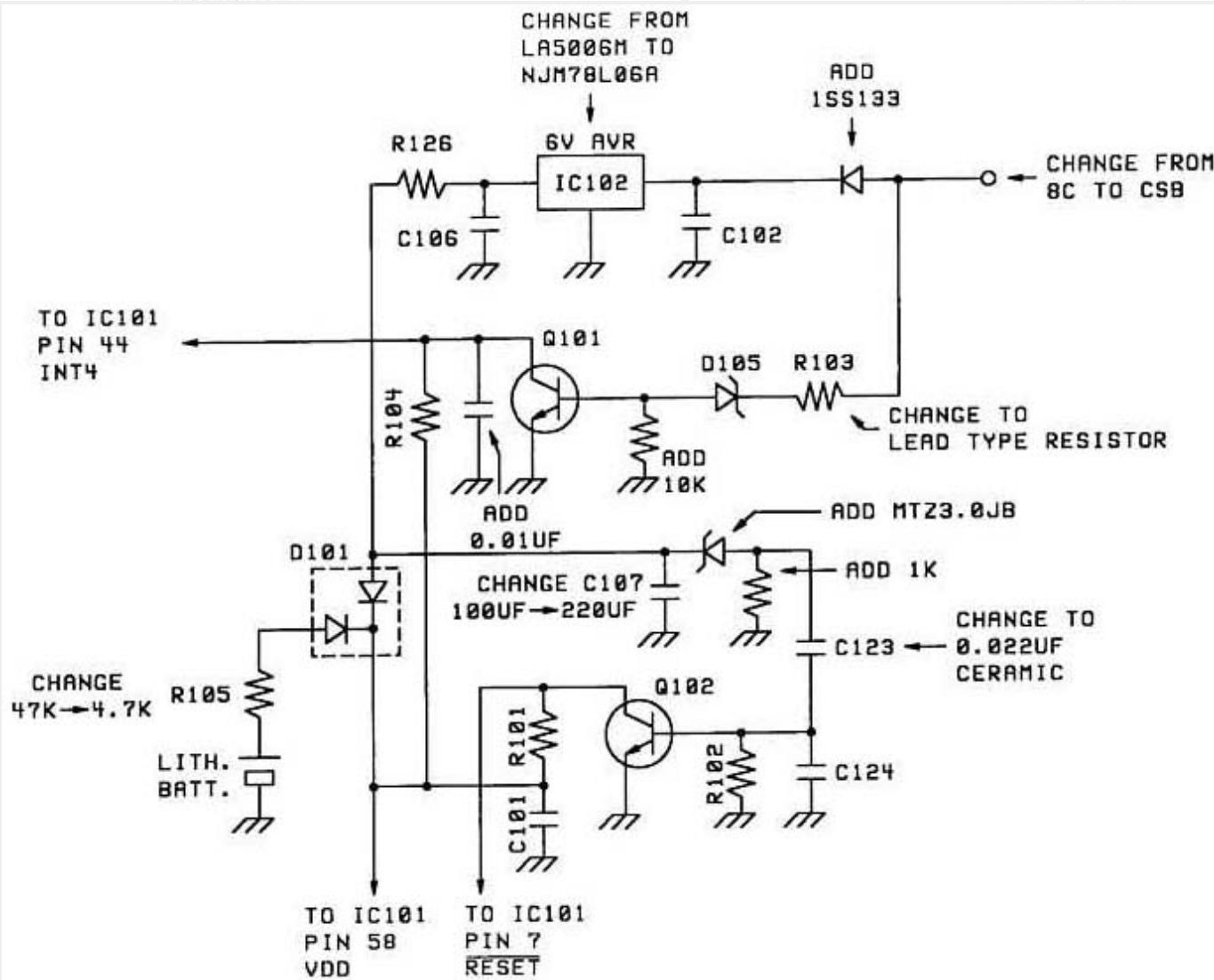

FIGURE 13



This modification may be covered under warranty.
Time required to perform this modification is 1 hour or less.

This modification is read 845 times.

[top of page](#)

21-04-2000

(TM-731) TM-731A/631A Final board C17 change

Author: Kenwood Communication, inc.

Service Bulletin no. 977 (8-8-1990)

Bypass capacitor C17 on the 144 MHz Final board has been changed in production from a "flat package" chip capacitor to a "cylindrical package". The change prevents the capacitor from fracturing. If C17 fractures, the output of the power module can burn C17, R11, and L6. Additionally, Q1 on the TX/RX 144 MHz board may be damaged.

C17 should be changed as a part of routine maintenance when a TM-731A/631A is received for service. The new style capacitor part number is CK41FY1E102M. For field service, a 0.001 μ F, 25 V disc ceramic capacitor can be used.

The production change started at serial number 108xxxx.

To replace C17:

1. Disconnect the power supply and antenna.
2. Remove the top cover. Do not damage the speaker wires.
3. Remove the shield plate from the VHF Final unit (4 screws). Figure 1.
4. Remove the 7 screws that secure the final board to the chassis. Figure 2.
5. Remove the 2 screws that secure the power module to the chassis. Figure 2.

6. Remove the 2 screws that secure the VHF antenna coax to the heat sink.
7. Desolder the center conductor and shield of the VHF antenna coax from the final board and pull the coax out of the heat sink. Figure 2.
8. Desolder the terminal next to pin 3 of the power module. Figure 2.
9. Rotate the board toward the front of the transceiver to expose the foil side of the board.
10. Inspect the solder at the terminals the antenna coax was soldered to. They may need to be resoldered.
11. Replace C17. Figure 3.
12. If you are serving a TM-731A/631A that has been damaged, check R11 and L6. The coil may have pin hole burn marks in its insulation and the resistor may be open. In addition, check Q1 on the RX/TX (144 MHz) board. If it is damaged, the receiver sensitivity will be low.
13. If the Final board has been burned, it can be repaired. The carbon must be completely removed from the board to prevent the board from burning any further (carbon tracking of the RF signal). The burned area should be filled with epoxy and the lands must be repaired.

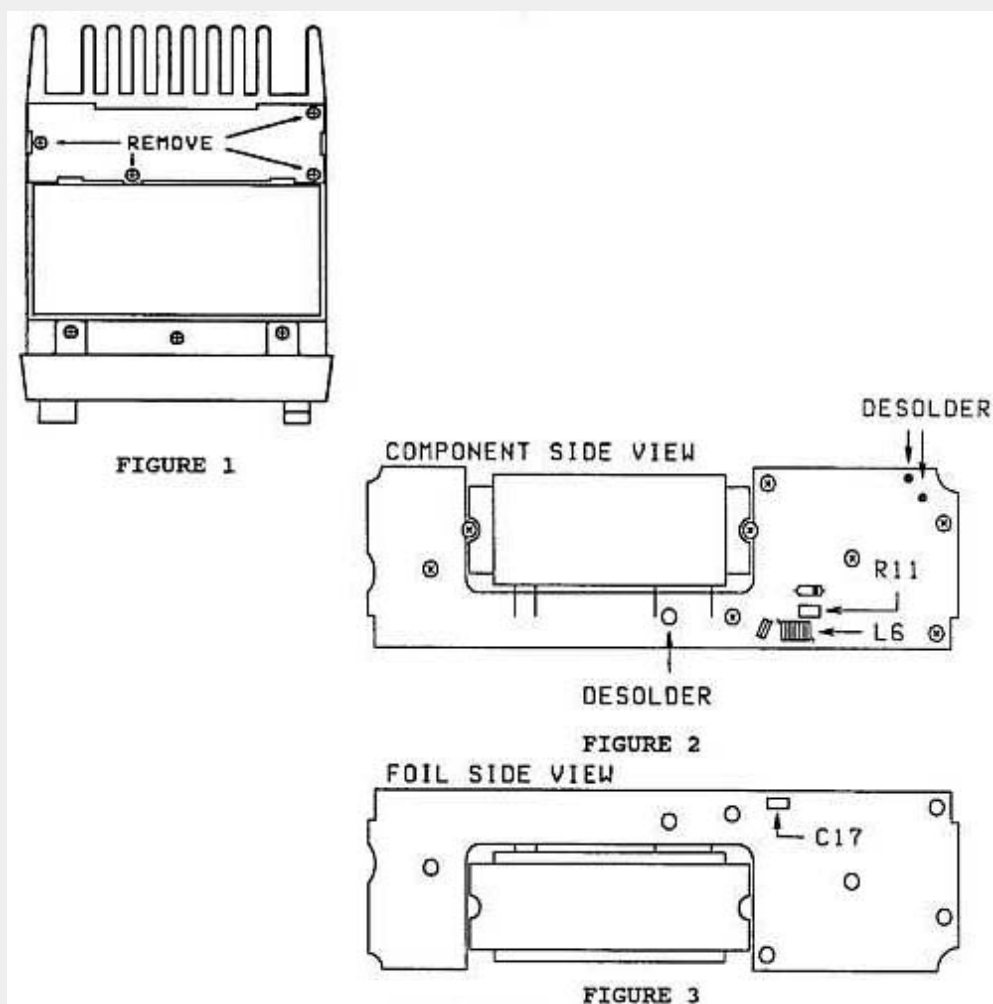

This modification may be covered under warranty during the warranty period.
Time required to perform this modification is 1 hour or less.

This modification is read 828 times.

[top of page](#)

12-03-2002

(TM-731) TM-731e Frequenz erweiterung

Author: - m.l@gno.de.MODIFICATION.NET

Frequenz erweiterung für TM-731E 136-174 MHz und 400-500 MHz!

1. Beide Gehäuseteile entfernen!
2. Die Displayeinheit demontieren!(Control Unit x53-3250-xx)
3. Nur die R25 entfernen! nicht wie in der amerikanischen ausführung!
4. Zusammenbauen und einen Reset durchführen! (MR gedrückt halten und Gerät einschalten! (RESET)) Das wars dann auch schon und müßte funktionieren!

Viel glück!

This modification is read 136 times.

[top of page](#)

19-07-1998

(TM-732) AIR CLONING (Does not work in K1 or E1 Mod modes)

This procedure allows you to clone a second transceiver as above, over the air. The data is transmitted automatically using DTMF tones. During transmission (which is one-way only), the master will automatically switch to LOW power. To be legal, use only a UHF cloning frequency.

This procedure is not enabled in the stock transceiver. At a minimum, you must cut the green wire to make it work.

1. Configure master transceiver's memories as desired. Select UHF simplex transmit frequency and set PTT to UHF (will work on VHF but is not recommended).
2. Switch the power OFF. Press and hold the CALL and DTSS buttons and turn the power back ON. "CLonE" appears in display.
3. Set the receive frequency on the slave transceiver the same as that of the master. Turn power off, hold down call and dtss keys and turn power on. 'clone' appears in display.
4. Press the ptt on the master's microphone. Data transmission will begin. In case of a receive error, the slave transceiver will display 'err'. when the procedure is complete, both radios will display 'end'.

This modification is read 938 times.

[top of page](#)

19-07-1998

(TM-732) PAGING ANSWERBACK (Does not work in K1 or E1 Mod modes)

The exact operation of this feature is unclear but the following description has been given:

1. To enable, hold down the F key and press the TONE key.
2. To disable, repeat step 1

When enabled, documentation says: "If a matching code is received and the other transceiver is no longer BUSY, the code of the local transceiver is sent to the other transceiver. The answerback function then turns off."

This modification is read 886 times.

[top of page](#)

19-07-1998

(TM-732) Memory recovery

(requires DTMF microphone)

(Documentation of this "feature" is difficult to comprehend but perhaps someone will figure out what it does.. I suspect that "RECOVERY" refers to returning the memories to their original state after changing the split memory layout.)

1. Hold down F and C.SEL, turn on power
2. Press D, followed by 7 on the microphone. "Inspection Mode" is now enabled.
3. To cancel, press and hold F and then C.SEL

"Note:

Before recovery, the memory channels must be returned to the previous state (number of split memories, etc.)."

This modification is read 919 times.

[top of page](#)

19-07-1998

(TM-732) Subjective Impressions

Being a TM-741 owner, there were a couple of things that I missed on the 732. First, there's no real-time clock, no sleep timer, no programmable ON time/ OFF time feature. There is an APO (automatic power off) with a preset time of 2:59:00 of inactivity until power down.

Another complaint is the slow scanning speed. The unit will scan VFO or memory at no more than about 5 channels/frequencies per second per band. I consider this to be terribly slow in today's age. The slowness is probably due to the fact that the remote contains all of the scanning logic and because the data path between the head and the base is over a 2 wire serial data stream.

Another perennial complaint is that the radio does not cover the entire UHF frequency band of 420-450 Mhz. As shipped, the unit will only operate over the range from 438 to 450, (transmit or receive) which I find objectionable.

The manual is of typical quality and fairly complete although not well indexed. There are so many functions that a cheat sheet is needed but as mentioned, was sadly not included. In typical fashion I note that the Japanese have never been able to adequately and clearly explain how DTMF Squelch and Paging works. They've tried diagrams and jinglish explanations but in the end you still end up reading the instructions over and over before you fully understand them. I'd love to see a plain English discussion of how the DTMF features are intended to work and how they really work in practice. Follow that with a step by step example and we'd probably have something that could be more popular.

One of my reasons for buying the radio was to use the remote mounted head option. The option, the PG-4K kit, is advertised as a 13 foot extension. What you don't find out until you buy it, however, is that only the display cable is 13 feet long and the microphone cable is only half that! To me this meant that although the display cable would let me trunk mount the base, there was no way I could get by with a 6 foot microphone cable. The solution: buy the PG-4M(?) which is the longer model for another \$30! Needless to say, I'm not a happy camper! Are you listening Kenwood????

On a positive note about the remote cabling, at least with the 732 it is possible to roll your own. The 4 conductor head to chassis connector cable could be easily spliced and extended, and an ordinary RJ-45 extension cable could be used for the microphone. For many folks, however, it's probably easier to just buy the short (\$47) or the long (\$78) cable kit.

The extension cable issue aside however, it still looks like it will be a very good radio. As always, after spending a big wad of cash I'm automatically inclined to say that I like the radio. This is no exception, the TM-732 does a fine job at heading off the competition at a good price-performance point.

The price is the same as the older TM-731 which was around \$650 retail (real price, not the bogus MSRP).

To conclude, I think Kenwood has come up with a fine replacement for the 731, and has put a lot of thought into the design of the 732.

Operating Features

Kenwood has done a fairly good job at maintaining a consistent user interface between their models. Being familiar with the 241 and 741, I found it pretty intuitive to operate. Not intuitive enough, however, to venture out of the house without taking the operators manual along since they sadly omitted a quick reference card (like the give out with the 741). Unless otherwise noted, the 732 generally has the same basic feature set as the TM-241 plus several extras.

The following is an unordered list of outstanding bits of trivia regarding the 732's features:

1. Dual In-Band Receive: Competitive pressures (e.g. Icom's 2410) has now made this a standard. You can set the display to receive any combination of: VHF/UHF, VHF/VHF or UHF/UHF. This capability is quite well engineered and makes it possible to transmit as well as receive on either band's second display. It is not possible (understandably) to have a full duplex QSO on an in-band setup. In other words, when you set the radio to monitor two UHF or two VHF frequencies, one of these frequencies is muted when you transmit on the other. This is not so when the selection is VHF/UHF, where the receiving band is not muted during transmit.

Looking at the schematic, the dual in-band receive is well implemented with each of the transceiver boards having two receiver front end units (RF amp and mixers), one for each band. There are some unsymmetrical aspects to the dual in-band receive. First, the UHF receiver does not have an AM mode which means that you cannot monitor AM aircraft spectrum at 118-136 MHz with the UHF receiver. Similarly, you cannot monitor 800 MHz with the VHF receiver. Each of these modes AM aircraft and 800 MHz, are unique to the VHF and UHF receivers respectively.

A nice touch is that even though the second receiver is utilized on the other band, the transmitter is automatically switched back to the proper band which allows you to transmit on either of the two frequencies while using the dual in-band mode.

2. Smart Mute: The MUTE function is now intelligent in that it mutes the non-PTT band only when necessary. This means that the audio muting (actually, 20Db of audio attenuation) is switched into the auxiliary band only when something is being received on the primary band. Previous Kenwood rigs muted the auxiliary band at all times when the MUTE function was active.

3. More programmable microphone function keys: Previous Kenwoods allowed you to program the PF microphone key only. With the 732, you may program any of the top 4 function keys (CALL, VFO, MR and PF), even for example, with such multi-key sequences as [F][VFO].

4. New Display Lighting: The display is the now-standard black letters on a light background. Like the 741, it has 4 light levels, plus OFF (no light) which is interesting. Also, there's a special feature which when enabled makes the display jump up to the next brighter display level whenever a button or key is pressed, returning to the dim level after 5 seconds of inactivity. When used with the OFF level it gives you a display which is completely dark at night and comes on only when you need it. There is, however, a small green

LED off of the display which remains lit at all times to show which band is in use.

5. Memory: As advertised the radio comes with 25 full-however, is that you can have up to 64 memories if you are willing to forgo the odd-offset capability to varying degrees. For example, if you can live with only 5 odd-offsets then you'll get 30 memories per band. If you don't need any odd-offsets then you get 32 memories per band. In addition, you can apportion the 64 available slots between the two bands in whatever ratio that you desire (in 5 channel increments). In other words, you can configure for 50 UHF memories and 14 VHF memories if you like.

M	22	21	20	19	VHF	UHF	SHIFT	800	REMARKS
K1	0	1	0	1	144-148	438-450	.6/5		STD. US VERSION
K2	1	1	0	1	144-148	438-450	.6/5	X	US AFTER GREEN WIRE CUT
K3	1	0	0	1	142-152	420-450	.6/5	XF	MARS/CAP MOD
K4	0	1	1	0	136-174	410-470	.6/5	X	ALL BAND MOD
M1	0	0	0	0	144-148	430-440	.6/5		GENERIC INT'L MODEL
M2	0	1	0	0	136-174	410-470	.6/5	X	ALL BAND INT'L (430 DEFAULT)
E1	0	0	1	0	144-146	430-440	.6/(1.6)		STD EUROPE MODEL
E2	1	0	1	0	136-174	432-438	.6/1.6	X	DENMARK
E3	0	0	1	1	144-146	410-470	.6/(1.6)	X	
E4	1	1	0	0	144-146	430-440	.6/(1.6)	X	
E5	1	0	1	1	136-174	410-470	.6/(1.6)	X	EUROPE ALL BAND
C1	0	0	0	1	136-174	340-512	5.7/10		CHINA MODEL

0 = RESISTOR IN 1 = RESISTOR OUT

Notes:

1. All 'resistors' 0 ohms (wire jumper ok)
2. Green wire is equivalent to R22 - present in K1 model Press ENTER to continue (A to abort) -->
3. 0 = RESISTOR PRESENT, 1 = RESISTOR ABSENT
4. Standard shifts in MHz VHF/UHF. those listed as (1.6) also DO -7.6
5. Codes not listed are used in japan version, special cpu required
6. M Column is factory mode number
7. K2 mod includes 410-770 receive and enables cloning feature to perform any of these mods, remove the back cover from the remote head unit. Resistor numbers clearly marked on board along top.

This modification is read 958 times.

[top of page](#)

19-07-1998 (TM-732) 800 MHZ RECEIVE

To enable 800 receive, switch to uhf vfo (not available in uxu), press and hold mhz button until 800.000 appears.

A capacitor must be added (c348) to enable the 800 receiver.

to add, remove uhf transceiver board and next to the pad of n 1 of ic-202 (on the foil side), add a 2.2 pf chip capacitor. a wire can be used instead of the capacitor but sensitivity will be reduced. (see schematic diagram for reason).

This modification is read 1138 times.

[top of page](#)

19-07-1998 (TM-732) Hard-wire cloning

(works in all configuration modes)

This procedure allows you to clone the entire memory of a 'maer' transceiver into the memory of a 'slave' transceiver.

First, construct an rj-45 jumper cable as follows:

```
-----!                               !-----
UP ----- UP                          Note that ptt and down
E ----- E                            are crossed end-to-end
PTT ----- DOWN
DOWN ----- PTT
-----!                               !-----
```

For hacker's reference: UP=CLK, PTT=SO/, DOWN=SI

1. Configure the master transciever's memories as desired.
2. Switch power off, hold down f and mhz keys and switch power back on while holding keys. Display wi show 'clone'.
3. Set the slave transciever in the clone mode (as in step 2).
4. Plug the cable into the two radios (which end doesot matter).
5. Press the call button on the master. When 'end' is displayed, operation is complete.

This modification is read 896 times.

[top of page](#)

19-07-1998

(TM-732) TM-732E fuer 9600

Hallo, habe meinen Kenwood TM-732E erfolgreich umgebaut auf 9600Baud.

NF Ausgang zum TNC an TX-RX UNIT/430 MHz an IC201 (KCDO4) Pin 12 Signal DET.

NF Eingang vom TNC an TX-RX UNIT/430 MHz an Leitung R257 nach VR202 Sig.

MAX DEV.

PTT an Microfonbuche gegen Masse.

Fragen Ueber Box DBOIZ oder Digi DBOEND in 1200Baud oder 0202/521349.

73 55 Joerg aus Wuppertal DD8JM.

This modification is read 908 times.

[top of page](#)

19-07-1998

(TM-732) TM-732 gets hot

Cause:

De Fan on the backside doesn't work correctly.

Solution:

Solder a transistor (eg BSX20) clote to the Fan-connector:

Collector: to the Fan-connector (closest totthe 12V-wire)

Emmitor : to GND

Base : to 7808 regulator (closest pin to the Front)

The Fan will now operate whenever the transceiver is switched on.

This modification is read 985 times.

[top of page](#)

19-07-1998

(TM-732) AM detector control

The AM Detctor, which automatically comes on below 136 MHz, can be forced ON at any VHF frequency by pressing the F and MUTE keys while applying power. Radio continues to transmit FM but receives AM. Changing frequencies or memory channels will cancel the forced AM mode. This capability could be useful for listening to the USAF Thunderbirds which sometimes operate in the 143 MHZ band using AM.

This modification is read 976 times.

[top of page](#)

27-03-2000

(TM-732) Extended RX & TX Mods

Note this mod is for a Standard Kenwood TM732E (European) model type "E1". However if you have a USA version see the resistor matrix below for different configurations etc.

1. Remove power cables and coax etc. from radio.
2. By pressing the small release clip on the left of the display, remove the remote head from the main body of the radio.
3. Remove the access cover on the rear of the remote head unit.
4. Disconnect the white connector, leaving the remote head separate from the main body of the radio.
5. On the back of the remote head remove the two screws.
6. Now you should be able to see the PCB of the remote head.
7. If you look above the white connector "CN 1" you will see four "0" Ohm resistor positions, labeled R19,R20,R21 & R22.
8. You need to configure the resistors as in the photo below.

Photo shows radio after modification.

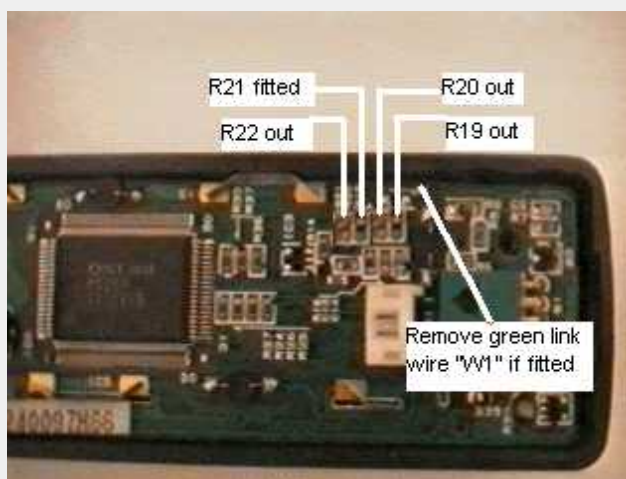

Modification matrix for the KENWOOD TM-732

Model	Resistors				TX Ranges		STD	800MHz	Remarks
	22	21	20	19	VHF	UHF			
K1	0	1	0	1	144-148	438-450	.6/5		Std. US Version
K2	1	1	0	1	144-148	438-450	.6/5	x	US After green wire cut
K3	1	0	0	1	142-152	420-450	.6/5	x	MARS/CAP Mod
K4	0	1	1	0	136-174	410-470	.6/5	x	All Band Mod
M1	0	0	0	0	144-148	430-440	.6/5		Generic Int'l Model
M2	0	1	0	0	136-174	410-470	.6/5	x	All Band Int'l (430 default)
E1	0	0	1	0	144-146	430-440	.6/(1.6)		Std Europe Model
E2	1	0	1	0	136-174	432-438	.6/1.6	x	Denmark
E3	0	0	1	1	144-146	410-470	.6/(1.6)	x	
E4	1	1	0	0	144-146	430-440	.6/(1.6)	x	
E5	1	0	1	1	136-174	410-470	.6/(1.6)	x	Europe All Band
TX/RX									
C1	0	0	0	1	136-174	340-512	5.7/10		China Model

Notes:

1. All "resistors" 0 ohms (wire jumper OK)
2. Green wire is equivalent to R22 - present in K1 model
3. 0 = resistor present, 1 = resistor absent
4. Standard shifts in MHz VHF/UHF. Those listed as (1.6) also do -7.6
5. Codes not listed are used in Japan version, special CPU required
6. M column is factory MODE number
7. K2 Mod includes 410-470 RECEIVE and enables CLONING features

This modification works 100% on my Kenwood TM732E. If you decide to carryout the same modification on your Kenwood TM732, then you do so at your own risk.

27-03-2000

(TM-732) 9600 baud UHF packet radio mods

Author: Colin G1IVG - colinlowe@jet.es.MODIFICATION.NET

Note: These mods are for 9600 baud on 70cms (UHF) only.

9600 TX mods (UHF).

1. Find the TX audio deviation potentiometer VR202 (47K).
2. You need to feed the TNC's 9600 baud TX audio, to a point between VR202 and resistor R257 (27K). This must be fed in series with a 0.1uf ceramic capacitor and a 56k ¼ watt resistor. Use screened cable and connect the screen to a nearby GND connection. On my radio I connected the TX Audio to the actual potentiometer, were it leads to R257.

9600 RX mods (UHF).

Find IC201 (FM IF module). Connect a screened wire from pin 12 (DET) to your TNC's 9600 baud RX audio input. Connect the screen to a nearby GND connection.

PTT Connection.

Remove the front panel and gain access to the PCB of the control head. You need to connect a wire from the PTT line of your TNC to the PCB at back of the MIC connector. Pin 5 of the MIC connector is the PTT.

1200 baud Packet Connection.

For normal 1200 baud packet use, just connect your TNC to the MIC connector, for all TX and RX audio plus the PTT control.

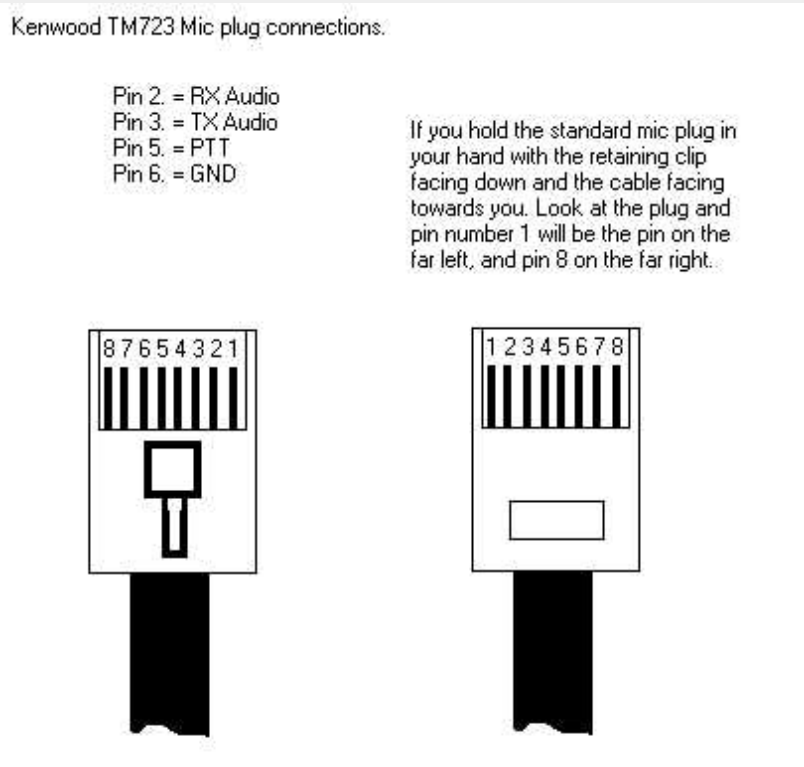

This modification is read 911 times.

[top of page](#)

21-04-2000

(TM-732) TM-732A 2 Meter transmit interference on 70 CM

Author: Kenwood Communication, inc.

Service Bulletin no. 996 (20 May 1992)

Reports of 70 cm receiver interference might occur when transmission is attempted on two meters. This is caused by a harmonic relationship that occurs between 2 meter frequencies and the IF image frequency. The resulting signal enters IC201 (FM HIC) on the 8R line of the 430 MHz TX/RX unit.

Addition of a chip bead and bypass capacitor on the 8R line will correct this tendency.

Parts required:

470 pF chip capacitor
Chip bead

CK73FB1H471K
L92-0131-05

Note: Don't confuse the chip capacitor with the chip bead. They have the same shape. The chip bead is black and the chip capacitor is brown so it should be a simple matter to identify the correct part.

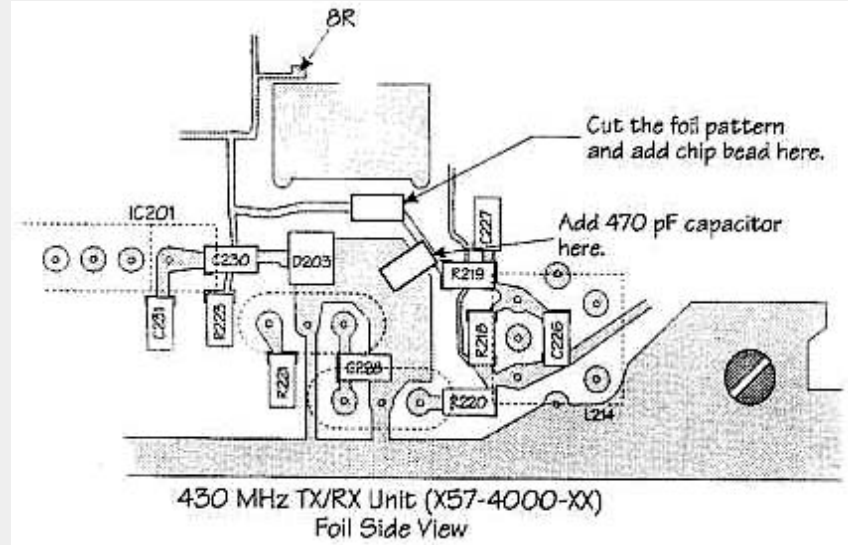

Time required for this modification is 30 minutes.

This modification is read 966 times.

[top of page](#)

22-04-2000

(TM-732) TM-732A/E Change in chip fuse rating

Author: Kenwood Communication, inc.

Service Bulletin no. 1005 (10 May 1993)

Parts change:

Change the chip fuse from 1 A to 1.2 A in the 430 MHz unit (X57-4000-11 B/4) whenever servicing this board.

Parts required:

F201, chip fuse, 1.2 Amp, (F53-0095-05), QTY. 1

Caution: This modification requires soldering equipment rated for CMOS type circuits. It also requires familiarity with surface mount soldering techniques. If you do not have the proper equipment or knowledge do not attempt this modification yourself. Seek qualified assistance.

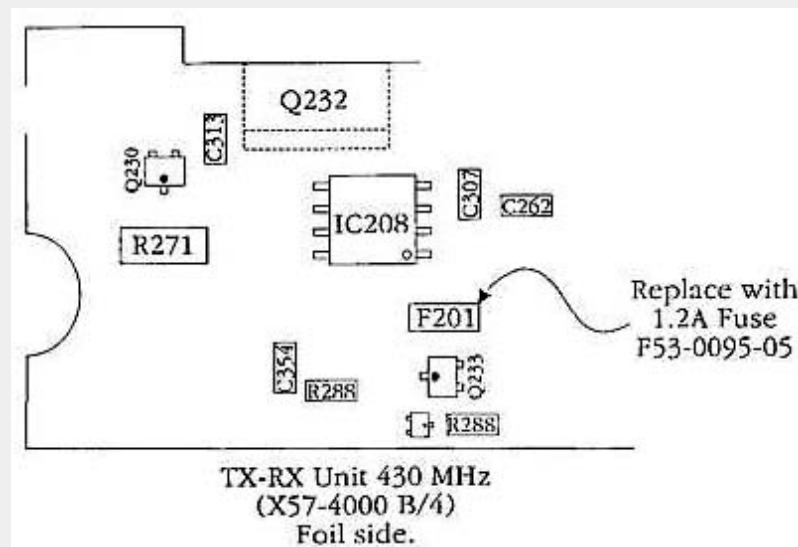

Time required for this modification is 15 minutes or less.

This modification is read 907 times.

[top of page](#)

Author: Kenwood Communication, inc.

Service Bulletin no. 1011 (3 May 1993)

Symptom:

Improper DTMF operation and low microphone audio have been reported by several owners of the TM-732A when the units are operated in the Cross-band repeat mode.

Parts required:

R468	39 Kohm chip resistor	RK73FB2A393J	QTY. 1
C453	.01 μ F chip capacitor	CK73FB1E103K	QTY. 1

Procedure:

1. Detach the front panel assembly from the chassis.
2. Remove the top and bottom covers from the chassis.
3. Remove the small countersunk Phillips head screws from the sides of the chassis. These are used to secure the two brackets that holds the plastic front cover to the chassis. Gently pull the plastic cover assembly forward and remove it from the chassis.
4. The TX/RX Control unit should now be visible on the front of the chassis assembly.
5. Replace R468 and C453 shown in the accompanying diagram.
6. Reverse steps 1 - 3 to reassemble the transceiver.

No additional adjustment or modification will be required.

Caution: This modification requires soldering equipment rated for CMOS type circuits. It also requires familiarity with surface mount soldering techniques. If you do not have the proper equipment or knowledge do not attempt this modification yourself. Seek qualified assistance.

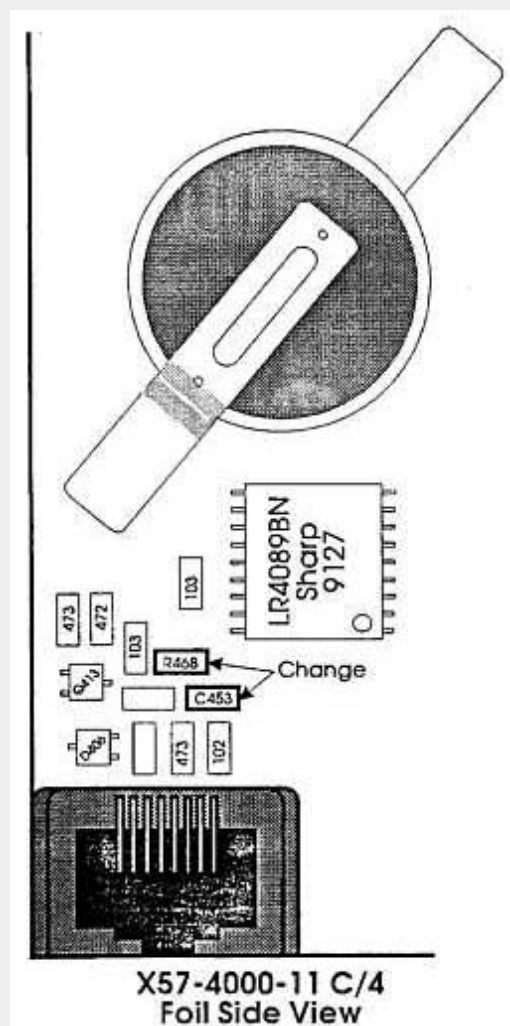

Time required for this modification is 30 minutes or less.

22-04-2000

(TM-732) TM-732A/E Noise at squelch ON/OFF

Author: Kenwood Communication, inc.

Service Bulletin no. 1014 (10 May 1993)

Symptom:

While receiving a signal on one band a noise is heard in the speaker whenever the squelch on the other band opens or closes.

Correct Action:

Add a 330 ohm resistor and 4.7 μ F capacitor to the 5C line in the control unit (X57-4000-11 C/4). Cut the 5C line and add the 330 ohm resistor in series.

Parts required:

330 ohm resistor	RD14BB2C331J	QTY. 1
4.7 μ F capacitor	C92-0507-05	QTY. 1

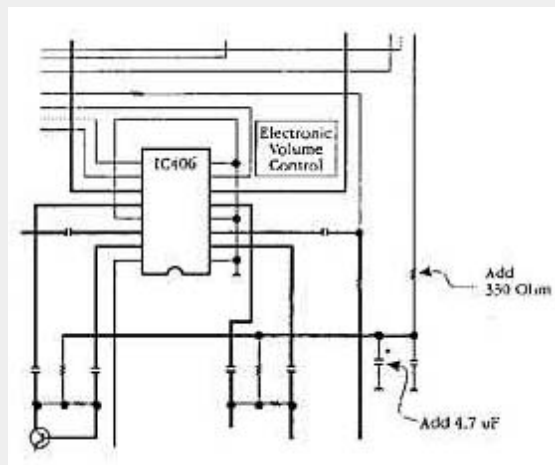

Caution: This modification requires soldering equipment rated for CMOS type circuits. It also requires familiarity with surface mount soldering techniques. If you do not have the proper equipment or knowledge do not attempt this modification yourself. Seek qualified assistance.

Time required for this modification is 30 minutes or less.

This modification is read 879 times.

[top of page](#)

23-04-2000

(TM-732) TM-732A S-meter squelch scan stop improvement

Author: Kenwood Communication, inc.

Service Bulletin no. 1023 (26 May 1993)

Symptom:

On some early versions of the TM-732 scan will not stop when operating in the S-meter squelch mode, even when the transceiver receives a signal with the same level as specified when initiating the S-meter squelch mode.

Correct action:

Change the value of C42 in the 144 MHz TX/RX unit (X57-4000 A/4) and C242 in the 430 MHz TX/RX unit (X57-4000 B/4) from 1 μ F to 0.47 μ F.

Parts required:

Qty	Description	Kenwood Part No.	Circuit description
2	0.47 μ F capacitor	CK73FF1C474Z	C42, C242

Caution: This modification requires soldering equipment rated for CMOS

type circuits. It also requires familiarity with surface mount soldering techniques. If you do not have the proper equipment or knowledge do not attempt this modification yourself. Seek qualified assistance.

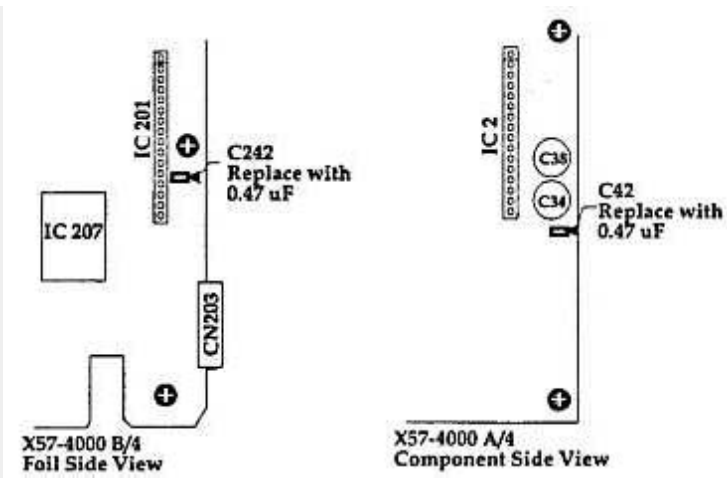

Time required for this modification is 30 minutes or less.

This modification is read 870 times.

[top of page](#)

23-04-2000

(TM-732) TM-732A Protection of Q201 in 430 MHz unit

Author: Kenwood Communication, inc.

Service Bulletin no. 1027 (28 June 1993)

Symptom:

Q201 the first RF amplifier in the 430 MHz unit fails at random.

Corrective action:

Addition of diode D218 in parallel with diode D214 in the RA line provides increased surge protection for Q201.

Parts required:

Qty	Description	Kenwood Part No.	Circuit description
1	Diode	HSK277	D218

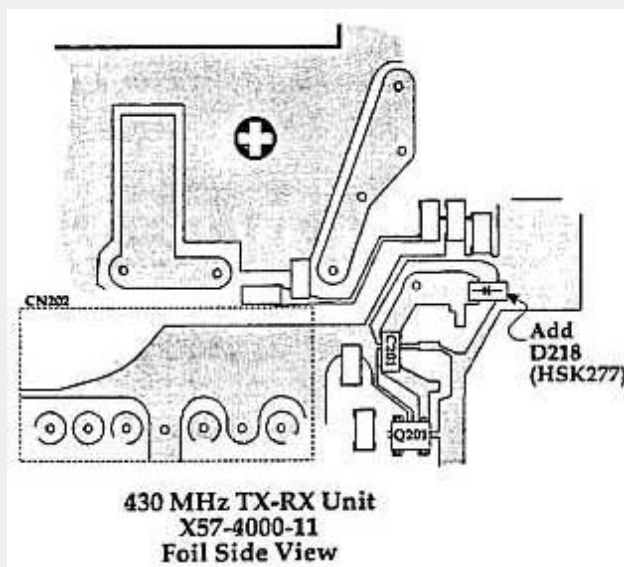

Caution: *This modification requires soldering equipment rated for CMOS type circuits. It also requires familiarity with surface mount soldering techniques. If you do not have the proper equipment or knowledge do not attempt this modification yourself. Seek qualified assistance.*

Time required for this modification is 30 minutes or less.

This modification is read 898 times.

[top of page](#)

23-04-2000

(TM-732) TM-732A Control PC Board B+ foil damage

Author: Kenwood Communication, inc.

Service Bulletin no. 1051 (28 March 1994)

Symptom:

Unable to turn on the power. No DISPLAY illumination, radio does not function.

Countermeasure:

The B+ circuit foil path near connector CN403 of the CONTROL units is burned open. This symptom can occur when the front panel is unplugged from the main chassis while the power is still turned on. Adding the resistor shown in series with the "B" line will help to limit current flow and prevent/limit this symptom from occurring.

Parts required:

Qty	Description	New Part No.	Circuit Description
1	4.7 ohm chip resistor	R92-1281-05	R290

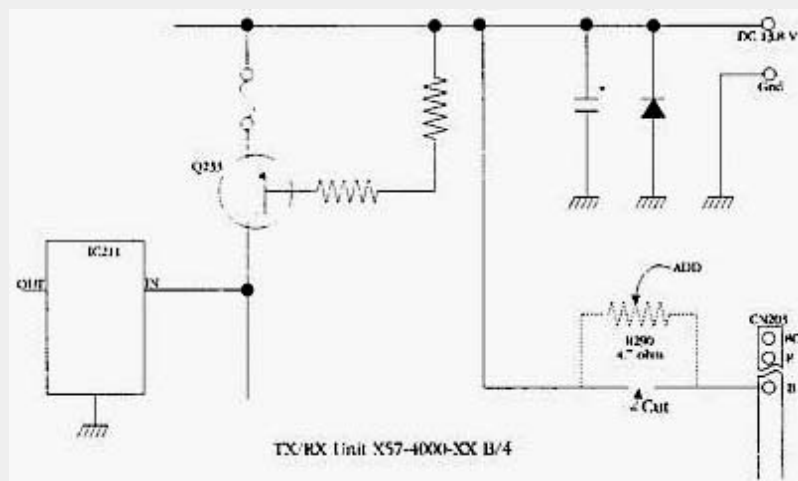

Caution: This modification requires soldering equipment rated for CMOS type circuits. It also requires familiarity with surface mount soldering techniques. If you do not have the proper equipment or knowledge do not attempt this modification yourself. Seek qualified assistance from your closest Kenwood Service Center (Long Beach, CA, or Virginia Beach, VA).

Time required for this modification is 60 minutes or less.

This modification is read 889 times.

[top of page](#)

23-04-2000

(TM-732) TM-732A/E APC circuit improvement

Author: Kenwood Communication, inc.

Service Bulletin no. 1056 (28 March 1994)

Symptom:

Failure of APC circuit transistor Q232 can occasionally be attributed to the gain dispersion characteristic of the VHF power module. Some of these devices allow normal transmit power output even with reduced "DB" terminal voltages. If the units is then operated for extended transmit key down periods Q232 can overheat and fail.

Corrective Action:

1. Measure the transmit power output and the "DB" terminal voltage at a dial frequency of 145.02 MHz.
2. Add the 1 dB circuit if the transmitter power is 60 watt or greater and the "DB" terminal voltage is 10 Vdc or less.
3. After adding the attenuator, re-adjust the transmitter output power for 50 watt and check the "DB" voltage. The "DB" voltage should now fall between 10 and 11 Vdc. If it does not adjust the values for R98, R100, and R99 until this voltage range is obtained.

Parts required:

Qty	Description	New Part No.	Circuit Description
*	820 ohm chip resistor	RK73FB2A821J	R98, R100
*	470 ohm chip resistor	RK73FB2A471J	R98, R100
*	270 ohm chip resistor	RK73FB2A271J	R98, R100

*	5.6 ohm chip resistor	RK73FB2A5R6J	R99
*	10 ohm chip resistor	RK73FB2A100J	R99
*	18 ohm chip resistor	RK73FB2A108J	R99

* Note: Quantities vary depending upon level of attenuation required to meet requirement of step 3.

Pad Attenuation	R98,R100	R99
1 dB	820 ohm	5.6 ohm
2 dB	470 ohm	10 ohm
3 dB	270 ohm	18 ohm

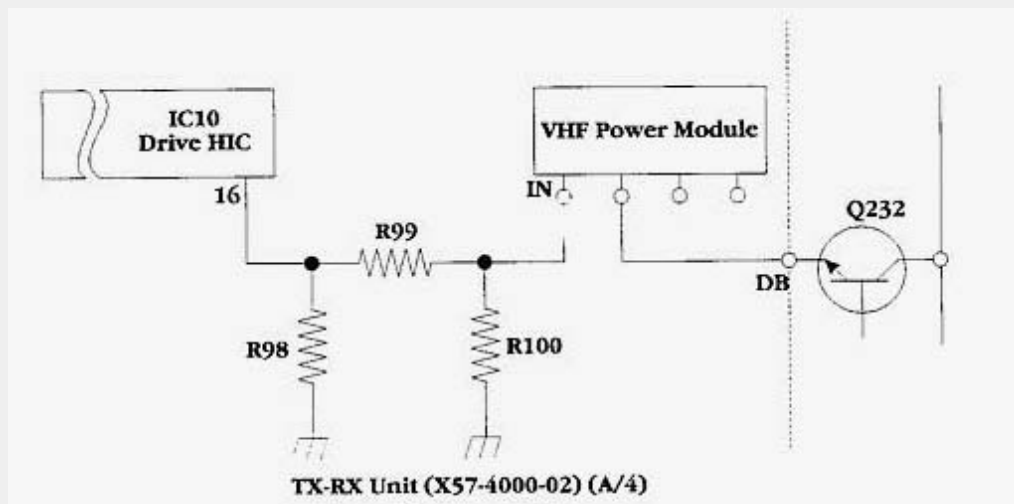

Time required for this modification is 60 minutes or less.

This modification is read 909 times.

[top of page](#)

23-12-2000

(TM-732) TM-732 partial display or no power up

Author: Pete Webster - GM7EEY - pete@broonbomb.com. MODIFICATION.NET

I have had 2 sets with similar faults.

On the back of the display board there is an electrolytic capacitor C8, this had leaked causing the through plated copper track to dissolve.

This track carries 5v from the regulator to the rest of the circuit, simply by soldering through a wire link cured the fault. My own set had a partial display with no RX but ok TX, it only showed the first 2 digits of the UHF band frequency. The other set would not power up at all until repaired.

This repair does mean removing the LCD display from the board so be very careful on assembly otherwise it will not function properly.

GM7EEY

This modification is read 940 times.

[top of page](#)

19-07-1998

(TM-733) TM733 with 2 antenna-sockets

Hello Kenwood-user,

As I started to use the TM733E on my 3 bander COMET 901 , I had to modify my transceiver. As I think some off you use a 3 way splitter to connect several transceivers at the same time there was a problem,I could not use the 23cm band and the splitter anymore sinds the TM733E came with only one antenna socket (mixed VHF and UHF).

After looking around in different shops, I was unable to find a splitter that had the UHF and VHF together on one socket and the 23cm band on another.

So I decided to have a look at the schematics off the TM733E and noticed the US version has 2 antenna sockets.

Modifying the rig is very simple:

Make a second antenna cable with PL259 socket or get it at your local Kenwood dealer (some 15\$) (same cable as on the other mobile dual banders ...TM701 etc.)Open both sides off the transceiver.

Take off the plastic cover off the spare hole at the back.

Insert and solder the new antenna cable.
Take away the connection (one big pin) from the VHF to the UHF pc-board with a good solderpump.
Your rig has now 2 antenna-inputs ,one for VHF ,one for UHF.

This mod. is also interesting for those who often use the CROSSBANDREPEATER, sinds you can now connect a vertical to the 70cm tx and a beam to the 2m part or the other way round.

Good luck with the modification and ...
have as much fun with the TM733E as i do !
73 de Jan ON1BJC @ ON4ABG

This modification is read 1435 times.

[top of page](#)

19-07-1998

(TM-733) TM733 and 9k6 Bps

As I first started to use the TM733E on 9600Bps ,it didn't work very well.
Rx 9600Bps was no problem but the TX-side was poor in transmission-speed.
After having a look at the SERVICE MANUAL i discovered that the audiosignal from the G3RUH should at least be 2 Volts PEP.
This information is not in the original manual delivered with the TM733E.
Txdelay starts at 200mS and combination nr 9 (strap settings G3RUH) seems to be the best to get minimum errors ...
Hoping to set some off you on the right track now...
73 de Jan ON1BJC @ ON4ABG

This modification is read 1218 times.

[top of page](#)

19-07-1998

(TM-733) TM733 & 9K6

Well John, i'm sorry i have to say this but the Kenwood TM733 is definitely NOT suited for 9600bd operation. It has several serious design bugs.

- PLL modulation, thereby giving very bad Bit Error Rate figures because of the bad lf response of the modulation circuits. At 64 Hz, there is a 4.5 dB rise.
- Slow tx<>rx switching. The TM733 needs 100-150 milliseconds to turn around. If your opponent (satellite or earth station) is faster with replying you keep on missing his first packet.

These problems are very common in the current generation "9600bd ready" transceivers. The Icom IC281/481, Yeasu 5100 and many others suffer from these problems.

The Kenwood TM733 has another design bug :

- If you try to make more than about 2.5 KHz deviation via the data port, the modulation gets very distorted. This is not easy noticable, since 9k6 modulation sounds like noise, and distorted 9k6 also sounds as noise.. This problem is seen at more than one TM733, throughout Europe.

I sure hope you can send this thing back and get your money back, John.

This modification is read 1158 times.

[top of page](#)

19-07-1998

(TM-733) TM-733E MOD 9k6 english

After I bought a Kenwood TM-733E transceiver for packet radio I was very disappointed about the bad modulation in the 9600 baud packet mode on the 430 mc band. For many digipeaters the transceiver produced insufficient fm deviation. If you increase the modulation voltage you will get a strong distortion of your signal. The german Kenwood office was unable or unwilling to fix this problem.

After some experiments I found the following solution for my transceiver:

Increase the internal packet radio modulation signal for the 70cm band by reducing the value of a SMD resistor. The resistor lives on the TX-RX Unit/Control board (X57-436X-XX)(C/4). The resistor is named R536 and it has a value of 56 kOhm. I reduced it's value by soldering an additional SMD resistor of 30 kOhm on it's top.

The two resistors form a new value of 19 kOhm. This will increase the modulation voltage for the PLL unit and you need less input signal on the data input at the socket J402. My transceiver makes now a deviation of 3.5 kHz with 1V/pp instead of 2.2 kHz with 2V/pp before.

There is less distortion than before. Concerning 9k6 packet radio the TM-733E has a bad frequency characteristic. It can be fixed with a suitable selection of the modem transmission filter. The following selection was the best for my TNC2H:

0 0 1 1 (switches 5 to 8, 1 = up, 0 = down).

Please note:

I am not responsible for your modifications.

You will do it at your own risk!

You need:

15 to 20 minutes time, a magnifying glass a screw driver (X), a needle type soldering iron and a SMD resistor of round about 30 kOhm

1. Remove the top cover (4 screws)
2. Remove the bottom cover (4 screws)
3. Remove the front panel (no screws!)
4. Remove the plastic front cover (6 plastic snappers)
5. Disconnect the two flat cables on the front board (shift the bolts)
6. Remove the front board (2 screws)
7. Find the SMD resistor named R536 (the print on the resistor reads 563, it is located on the back side of the front board between the two flat cable sockets, use a magnifying glass!)
8. Solder the 30 KOhm SMD resistor on top of the R536
9. Reassemble the other way round (good luck !)

When the modification is done you have to setup your modem (modulation voltage and filter selection) again.

Concerning Kenwoods bad support in germany my next packet radio tranceiver will be from a different manufacturer.

Please send me a message with your results. Good success!

vy 73 Norbert DC6BC @ DB0IZ.#NRW.DEU.EU

This modification is read 1181 times.

[top of page](#)

19-07-1998

(TM-733) MODS OF KENWOOD TM-733 for Japanese version

Maybe there are some difference for USA , EU and another vartion. So please use caution.

1. Remove the control panel. You can find CPU board.
2. Remove 2 screws on this board. Then turn insde out this board.
3. You can find a chip that printed [000] on this board.

```
-----  
I                xx                I      xx meams [ 000 ]  
I  O                O  I          O means hole of screw  
I                I  
-----
```

4. After remove this chip [000] , you can recieve as ffollows.

on 144MHz	on 430MHz
118-173MHz	118-173MHz
130-173MHz	300-469MHz
300-469MHz	800-900MHz

On 144MHz side , press [MHz] key more than 1 sec. , change mode for AM.

On 430MHz side , change band for 800Mhz.

This modification is read 1148 times.

[top of page](#)

19-07-1998

(TM-733) TM-733A Quick Reference Guide

Assembly Mode Test

In the TM-733 Service Manual, it describes a test mode that I haven't seen mentioned anywhere else. So, here's the scoop:

Entering Assembly Mode: [CALL] + [MUTE] + [Power On]

All LCD segments should come on. (To exit, power off.)

Press the [VFO] key. *This must always be done first*

The serial port is checked and "F" with "80" on the display indicates test passed. "1" or "2" means failure.

Different keys now show different displays, with [LOW], [SHIFT], [TONE], and [REV] also adjusting the backlight intensity.

Set the dials to minimum, then press the [MR] key. Each of the dials shows the digitized level.

This looks useful for checking all the keys and dials when you suspect a bad connection.

Kenwood TM-733A Quick Reference Guide by Brad Killebrew N5LJV

[#]	PRESS A NUMBER, NOT THE POUND SIGN.
[KEY]	PRESS AND RELEASE [KEY]
[KEY1]+[KEY2]	PRESS AND HOLD [KEY1] DOWN, THEN PRESS [KEY2]
[KEY1],[KEY2]	PRESS [KEY1] MOMENTARILY, THEN PRESS [KEY2]
[KEY]+[PWR]	WITH POWER OFF, PRESS AND HOLD [KEY] THEN HIT [PWR]
[KEY1]+[KEY2]+[PWR]	YOU GET THE IDEA.
[F] (1s)	PRESS AND HOLD [F] FOR ONE SECOND. "F" THEN BLINKS.
[KEY] (1s)	PRESS AND HOLD [KEY] FOR ONE SEOND.
[F],[KEY] (1s)	PRESS [F] MOMENTARILY, THEN PRESS [KEY] FOR ONE SEC.

The following entries are in alphabetical order.

1 MHZ/10 MHZ TUNING TOGGLE	[VFO],[F]+[MHZ]
ADVANCED INTERCEPT POINT (AIP)	[F]+[A.B.C.]
ALL LOCK	[F],[MHZ],[PWR],[F]+[PWR]
AM/FM MODE	[MHZ] (1s)
AUTO DIMMER CHANGE	[F]+[LOW]+[PWR]
AUTOMATIC BAND CHANGE (A.B.C.)	[F],[A.B.C.]
AUTOMATIC OFFET (CANCELLING)	[VFO]+[REV]+[PWR]
AUTOMATIC POWER OFF (APO)	[F] (1s),[MHZ]
AUTOMATIC SIMPLEX CHECKER	[REV] (1s)
AUTOMATIC SQUELCH	[MHZ] + [PWR]
AUTOMATIC TONE FREQUENCY ID	[TONE] (1s)
BAND SCAN	[VFO] (1s)
BEEP LOUDNESS	[F] (1s),[BEEP]
BLANKING A BAND DISPLAY	[F] (1s), [BAND SEL]
CALL CHANNEL CHANGING (ODD SPLIT)	(RX FR),[F],[C.IN] (1s),(TX FR)[CALL]
CALL CHANNEL CHANGING (SIMPLEX,DUPLEX)	[F],[C.IN]
CALL CHANNEL RECALLING	[CALL]
CALL/MEMORY SCAN	[MR],[CALL] (1s)
CALL/VFO SCAN	[VFO],[CALL] (1s)
CANCELLING AUTOMATIC OFFET	[VFO]+[REV]+[PWR]
CHANGING CALL CHANNEL (ODD SPLIT)	(RX FR),[F],[C.IN] (1s),(TX FR)[CALL]
CHANGING CALL CHANNEL (SIMPLEX,DUPLEX)	[F],[C.IN]
CHANNEL DISPLAY FUNCTION	[REV]+[PRW]
CONFIRMING PROGRAMMABLE LIMITS	[F]+[VFO],(L.SHOWN),[MR](U.SHOWN)
CTCSS	[TONE],TOGLE TILL "CT" APPEARS
CTCSS TONE FREQUENCY (SELECTING)	[F] (1s),[T.SEL],[UP]/[DOWN]
DIMMER (AUTO CHANGE)	[F]+[LOW]+[PWR]
DIMMER (DISPLAY)	[F],[DIM]
DISPLAY DIMMER	[F],[DIM]
DISPLAY DOMONSTRATION MODE	[CALL]+[PWR]
DTMF CONFIRMATION TONES	[PTT]+[DWN]+[PWR]
DTMF IN AUTOMATIC DIALER (STORING)	[F]+[CALL]+[PWR],[#'s],[PF],[#]
DTMF NUMBERS (RECALLING STORED)	[F]+[CALL]+[PWR],[MR],[#]
DTMF NUMBERS (TRANSMITTING STORED)	[PTT]+[PF],[#]
DUAL TONE SQUELCH SYSTEM (DTSS)	[F],[DTSS]
DUAL TONE SQUELCH SYSTEM (TONE SELECT)	[F] (1s),[C.SEL],[#],[SHIFT],ETC.
ERASING MEMORY CHANNELS	[MR],[F]+[MR]
ERASING PROGRAMMABLE MEMORY	[F]+[PM],[#],[MR]
FREQUENCY READOUT BY BEEPS	[F]+[TONE]+[PWR],[PF]
FREQUENCY STEP SIZE	[VFO],[F],[STEP]
FULL RESET (MINUS PM)	[MR]+[PWR],[F],[MR]
FULL RESET (PLUS PM)	[MR]+[PWR],[MR]
INITIALIZE FULL RESET (MINUS PM)	[MR]+[PWR],[F],[MR]
INITIALIZE FULL RESET (PLUS PM)	[MR]+[PWR],[MR]

INITIALIZE VFO BOTH BANDS	[VFO]+[PWR]
INITIALIZE VFO ONE BAND	[VFO]+[BAND SEL]+[PWR]
LOCK (ALL)	[F],[MHZ],[PWR],[F]+[PWR]
LOCK (TRANCEIVER)	[F],[MHZ]
LOCK (TRANSMIT BAND)	[F],[BAND SEL]
LOCKING OUT MEMORY CHANNELS	[MR],[F] (1s),[MR]
MEMORY CHANNELS (LOCKING OUT)	[MR],[F] (1s),[MR]
MEMORY ERASING CHANNELS	[MR],[F]+[MR]
MEMORY RECALLING CALL CHANNEL	[CALL]
MEMORY SCAN	[MR] (1s)
MEMORY TO VFO TRANSFER	[F],[VFO]
MEMORY WRITING (ODD SPLIT)	(RX FRQ),[F],[MR] (1s),(TX FRQ)[MR]
MEMORY WRITING (SIMPLEX, DUPLEX)	[F],[FREQ],[MR]
MUTE	[MUTE]
PACKET BAUD RATE TOGGLE	[F]+[STEP]
POWER OUTPUT	[LOW]
PROGRAMMABLE BAND SCAN	[F]+[VFO],[L.FRQ],[MR],[U.FRQ],[MR]
PROGRAMMABLE LIMITS (CONFIRMING)	[F]+[VFO],[L.SHOWN],[MR](U.SHOWN)
PROGRAMMABLE MEMORY (ERASING)	[F]+[PM],[#],[MR]
PROGRAMMABLE MEMORY (RECALLING)	[PM],[#]
PROGRAMMABLE MEMORY (STORING)	[F],[PM],[#]
PROGRAMMABLE MEMORY SCAN	[PM]+[PWR],[PM] (1s)
RD OUTPUT SQUELCH CONTROL	[TONE]+[PWR]
RECALLING MEMORY CALL CHANNEL	[CALL]
RECALLING PROGRAMMABLE MEMORY	[PM],[#]
RECALLING STORED DTMF NUMBERS	[F]+[CALL]+[PWR],[MR],[#]
RECEIVE AUDIO SWITCHING	[F] (1s) [CONT SEL]
REMOTE CONTROL MODE	[F]+[CONT SEL]
S-METER SQUELCH	[F] (1s), [S.QSL]
SCAN (BAND SCAN)	[VFO] (1s)
SCAN (CALL/MEMORY)	[MR],[CALL] (1s)
SCAN (CALL/VFO)	[VFO],[CALL] (1s)
SCAN (PROGRAMMABLE BAND SCAN)	[F]+[VFO],[L.FRQ],[MR],[U.FRQ],[MR]
SCAN (PROGRAMMABLE MEMORY)	[PM]+[PWR],[PM] (1s)
SCAN MEMORY	[MR] (1s)
SCAN RESUME TOGGLE (CO, TO)	[F] (1s),[VFO]
SELECTING A CTCSS TONE FREQUENCY	[F] (1s),[T.SEL],[UP]/[DOWN]
SQUELCH (AUTOMATIC)	[MHZ] + [PWR]
SQUELCH (RD OUTPUT CONTROL)	[TONE]+[PWR]
SQUELCH (S-METER)	[F] (1s), [S.QSL]
SQUELCH HANG TIME	[F]+[DIM]
STORING DTMF IN AUTOMATIC DIALER	[F]+[CALL]+[PWR],[#'s],[PF],[#]
STORING PROGRAMMABLE MEMORY	[F],[PM],[#]
TIME-OUT TIMER	[F] (1s),[TOT]
TOPE ALERT	[F],[T.ALT]
TOPE ALERT - CHANGE TONE	[F]+[SHIFT]+[PWR]
TRANCEIVER LOCK	[F],[MHZ]
TRANSMIT BAND LOCK	[F],[BAND SEL]
TRANSMITTING STORED DTMF NUMBERS	[PTT]+[PF],[#]
UHF+UHF OPERATION	[F],[CONT SEL]
VFO TUNING LIMITS	[F]+[C.IN],[L.FRQ][MR],[U.FRQ][MR]
VHF+VHF OPERATION	[F],[CONT SEL]
WRITING MEMORY (ODD SPLIT)	(RX FRQ),[F],[MR] (1s),(TX FRQ)[MR]
WRITING MEMORY (SIMPLEX, DUPLEX)	[F],[FREQ],[MR]

If you have additions or corrections to this file, please send it to Brad Killebrew N5LJV at n5lvj@uh.edu, or packet n5lvj@f6cnb.#setx.tx.usa.na.

Standard Disclaimer: The authors take absolutely no responsibility for the material presented in this document. The procedures contained herein work on the author's radios, but proceed at your own risk.

This modification is read 1338 times.

[top of page](#)

19-07-1998

(TM-733) Extended RF Modifications

Refer to diagram below.

Remove power source from the radio.

Remove the display panel.

Remove the top cover the radio.

Face the front of the radio away from you.

Remove the speaker.

Looking from the back of the radio, the control board is vertically mounted just behind the front panel wall (which can be removed easily if better access is needed.)

Just to the right of a chip labeled XRU4066BCF and just to the left of two green wires (B2 & B3 which are draped over the board to the rear) are two zero-ohm SMT resistors, B0 and B1, marked "000".

Remove B0. (the one on the left - furthest from the green wires)

Taking it out might be a bit tricky. It's glued down for surface-mount assembly. Be careful not to pull the trace from the board.

Perform a CPU reset by holding [MR] while turning on the radio.

It will then ask if it is "OK?" to reset, press [MR] again.

The ranges after modification are as follows:

Tx: 136-174 410-470

Rx: 118-174 300-470

The cellular band is indeed missing.

ONLY Removing Jumper 1 (B2) is the MARS/CAP modification.

** Diagram of specified area on Control Board **

EDGE OF BOARD, viewed from the rear, looking toward front panel

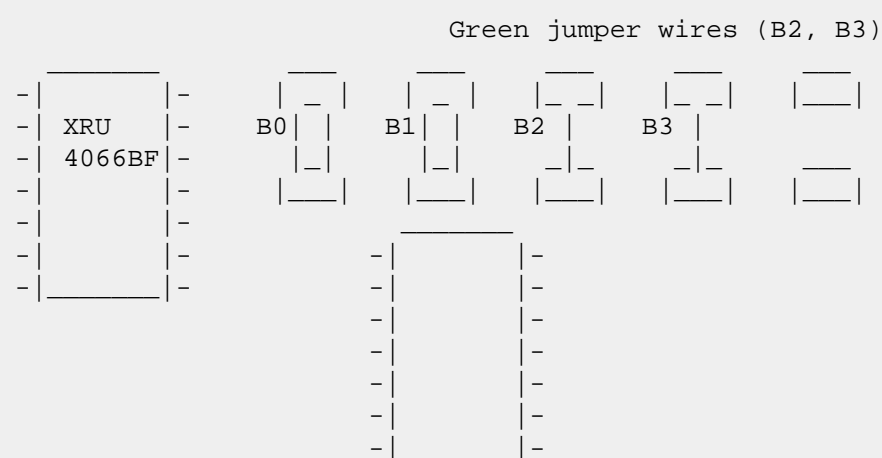

The jumpers are actually soldered on the other side of the board, but the loops come up over the top and hang over the B0/B1 side.

B0=R414

B1=R412

Here's something interesting! According the Kenwood rep I spoke to, performing this mod *does not* void your factory warranty. The same goes for any Kenwood published service bulletin or modification info. We are encouraged to perform the repairs ourselves to save them the trouble and expence.

This modification is read 1576 times.

[top of page](#)

19-07-1998

(TM-733) DTMF Remote via Microphone

The TM-733 is fully DTMF remotable via the microphone (documented). The radio can also be externally DTMF controllable with an HT, but that will be described later.

The DTMF control keys are exactly as shown on page 81 of the manual. Note that the microphone is active all the time, so any ambient DTMF tones near your mic will also change rig settings. This includes tones coming in on the other band and out the speaker.

Date: 30-01-2002

User comment

From: [KB7RBR / Bob Canestrini](#)

Subject: DTMF via Mike.

Kenwood describes a fix for this in their Application Note AAN-0003. The App note is for an MC-45DM but Kenwood states this same mod will work for the MC-53DM found on the TM-733.

I have not tried this mod yet as the part that Kenwood says to use (DTC1435) is an elusive one.

Date: 02-02-2002

User comment

From: [KB7RBR](#)

Subject: Live mike fix

Sorry everyone, I blew it in the above text. The AAN from Kenwood is [AAN-0021R1](#) and describes the "Correct" procedure for this fix.

The procedure takes about 15 minutes and requires a DTC143ES Transistor (Or Equivilent NTE2367) This is a digital transistor package that includes two biasing resistors.

1. Open the mike by removing the three rear screws.
2. Pull off the lock switch and clear plastic dust guard.
3. Locate the two Mike element solder joints on the back of the PCB.
4. Solder the Emitter and the Collector of the transistor across the mike element. (Note the Flat side of the transistor will face the PCB)
5. Solder a short length of wire to the Base lead from the transistor and run it to the solder pad junction of D2 and D3. (Lower Left corner of the PCB.)
6. I found it helpful to have a short length of shrink tube to insulate this lead.
7. Reassemble the mike and you're back on the air.

This mod has worked out fantastic for me...no more switching bands, power or frequency while monitoring a busy repeater.

73 de KB7RBR

This modification is read 1127 times.

[top of page](#)

19-07-1998

(TM-733) Cross Band Repeating

Cross band repeat isn't documented but comes ready from the factory.

To enable cross band repeat from the front panel, first select a band by pressing BAND SELECT. Then, change the control to the other band by hitting [CONT SEL]. Next, press [F] for one second, then the "X" button (far right side). Decimals will appear between the Kilohertz digits, and the "ON" indicator will light momentarily. The microphone sequence to enable cross band repeat while in remote control mode is "DC".

The transmitter hang time can be toggled between 500ms to 0ms by turning on the radio with [LOW] pressed. They also recommend enabling the Time-out Timer, for obvious reasons.

Note that the TM-733 can also be used as a "one-way" cross-band repeater.

For example, if you can receive a distant repeater with your HT, but have difficulty getting into it, you can use the TM-733 to boost your transmitted signal. To set this up, just omit the part where you "change the control to the other band by pressing [CONT SEL]." Doing this will setup the TM-733 to repeat your signal to the other band, but will not retransmit the distant station back to you. If this sounds ambiguous, play around with it a little and it will begin to make sense.

This modification is read 1365 times.

[top of page](#)

19-07-1998

(TM-733) DTMF Paging and Squelch

The DTMF Paging & DTMF Squelch protocol (AAA*BBB) is compatible with the Yaesu 530 and all Kenwood radios supporting this.

This modification is read 1072 times.

[top of page](#)

19-07-1998

(TM-733) Wireless Cloning

The advertised but undocumented Wireless Clone function is described in App Note AAN-0008 which they will mail out on request. (Maybe if enough people ask for it, they will include all the functions in future instruction manuals.) In summary:

- Prepare the two radios for simplex operation on the same frequency.
- Turn both radios off
- Press [CALL]+[SHIFT] + [Pwr On].
- This should place the radios in clone mode with "CLonE" on the display.
- Press PTT on the "Master" radio momentarily. This will start sending the programming DTMF tones.
- After all data has been transferred, the display of all radios will read "End", indicating success.
- If the signal is interrupted or corrupted, the "Slave" displays will read "Err". Turn them off and try again.

Notes:

- Both the Master and Slave radios must have the same number of memory channels available for each band. Example: You can not clone a stock Master to a Slave with ME-1 memory expansion.
- You can not clone between different Kenwood radio models, even if they seem identical.

Be careful when using the clone feature. It has been known to wipe out or scramble memories on the master radio during or right after clone.

This modification is read 1136 times.

[top of page](#)

19-07-1998

(TM-733) TM-733A PL Tone Distortion

Author: Kenwood Communication, inc.

Service Bulletin no. 1060 (30 August 1994)

Symptom:

Transmitted PL tones at the receiving station have a relatively high level of distortion. This is easily seen when the incoming signal is viewed on an oscilloscope.

Countermeasure

Change the value of the "Pull-up" resistors in the PL tone encoder circuit as shown in the accompanying chart and illustration. This reduces the distortion from around 9% to approximately 4%.

Part	OLD value	NEW value
R542	1.8k	2.7k
R543	1.8k	3.3k
R544	1.8k	4.7k
R545	1.8k	6.8k
R546	1.8k	10k
R547	1.8k	10k
R548	1.8k	10k

Procedure:

1. Disconnect the power cable, microphone and antenna's, etc.
2. Detach the front panel and set it aside.
3. Remove the top and bottom covers.
4. Remove the speaker and speaker mounting bracket.
5. Disengage the plastic front panel from the main chassis.
6. Carefully disconnect the two ribbon cables from the Tx/Rx unit C/4.
7. Remove the two Phillips head screws that secure the Tx/Rx unit to the chassis.
8. Turn the circuit board over and replace the resistors using the parts list and illustration as a guide.
9. Reverse steps 1-7 for reassembly.

TX-RX Unit (X57-4360-00) Foil Side View

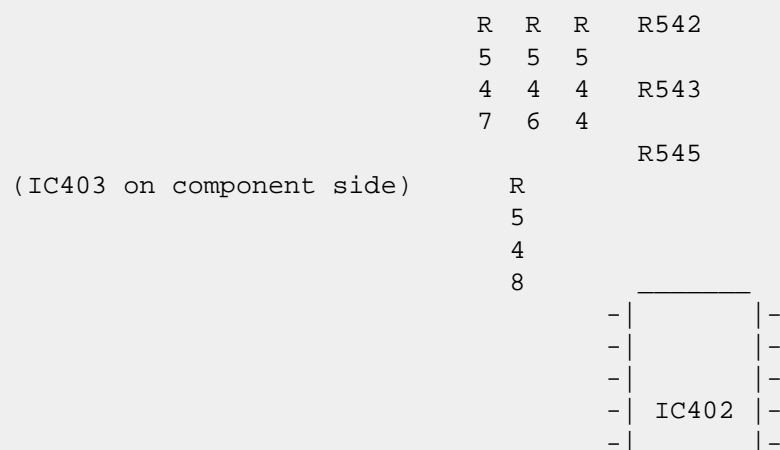

-| | -
-| | -

Caution: *This modification requires advanced surface mount soldering equipment that is rated for CMOS circuits. It also requires familiarity with advanced surface mount soldering techniques. If you do not have the proper equipment or knowledge do not attempt this modification yourself. Seek qualified assistance from your closest Kenwood Service Center (Long Beach, CA, or Virginia Beach, VA).*

Extra note, these notes is not from Kenwood.

The Service Manual specifies a test for the PL. The technician is simply required to verify that any one PL tone is between 500 and 1500 Hz deviation. This is quite a wide tolerance range! The "standard" PL tone deviation should be 750 Hz. Twice that strong might be too strong and become audible. There are no trim-pots on the PL deviation, so I'm guessing that the deviation is pretty constant from radio to radio.

The dirty PL is definitely found on early models, but we have had many reports that the PL problem has been fixed in newer versions of the radio. If you purchased your radio after September 15, 1994, (or your serial number is greater than 55000000) it's a good chance that you may not have the PL problem.

The other problem concerns the DTMF Confirmation Tones. This feature is off by default (I wonder why :), while it seems pretty useful. To turn it on, press [PTT] + [Down] on the microphone while powering the radio on. This will generate short DTMF confirmation tones whenever you send DTMF over the air from the keypad. Unfortunately, it mangles the beginning of the outgoing DTMF tone! This is serious enough that most local repeaters can't detect the tone, or count it as two tones.

Get a receiver and listen to what you are sending out when the Confirmation tones are enabled. It sounds to me like they may be mixing the confirmation tone in with the real tone and getting some destructive interference. Just a guess, though.

I called a Kenwood technician (Ricardo) and worked with him on the phone to reproduce the problem there. So, as of today, this is a Known Problem, and they are looking into a fix. :-)

I am really curious to know what they would say if other folks called up and complained about this problem. Would they deny hearing about it, or would it really be a Known Problem? Might give some insight into the PL-noise denial thing anyway. :-)

Personally, I'm much more concerned about the noisy PL than the DTMF confirmation tones, since I can just shut those off and pretend that feature doesn't exist. If enough people call about the PL problem, maybe they will come out with a real fix and offer it under warranty to all the radios out there (since they're all pretty new). My guess is that it will involve a free TSU-8 tone decode module, but don't hold your breath. :-)

This modification is read 1091 times.

[top of page](#)

19-07-1998

(TM-733) External DTMF Remote Control

The following procedure places the 733 in External DTMF Remote Control.

Note that this mode is different than DTMF Remote Mode. This mode concerns the control of the 733 with an HT, and not the microphone.

- Press Band Select and select the UHF band.
- Pick a UHF control frequency.
- Turn on the UHF DTSS function and select a tone sequence. (p. 89)
- Turn the UHF DTSS function back off.
- Press Band Select to move to the VHF band.
- Press [CONT SEL] to move control back to the UHF band.
- Turn OFF the radio, press and hold [CONT SEL] while turning the radio back on, then release [CONT SEL]. The S-meter scale and the DT indicators for the UHF band will begin flashing. The LOCK indicator will turn ON, and most front-panel keys (except PWR) will be disabled.
- To begin remote control, you should key the external radio and press the following key sequence: "Axxx#" where "xxx" is the preset DTSS code selected earlier.
- If the proper code is received by the 733, the beeper will sound and the DT indicator will stop flashing. The radio can now be remotely controlled using the function chart below.
- To return to standby mode, press "A#" on the remote radio.
- To return the radio to normal operation, turn the radio off, then press and hold [CONT SEL] while turning the radio back on.

Refer to this chart when using the TM-733 in "External DTMF Control".

1	2	3	A
T.ALT ON	TONE ON	CTCSS ON	ENTER
4	5	6	B

T.ALT OFF	TONE OFF	CTCSS OFF	TONE SEL
7	8	9	C
CALL	VFO	MEMORY	REPEATER ON
*	0	#	D
DOWN	POWER LEVEL	UP	REPEATER OFF

There are no "shifted" functions. Just one function per button.

After you hit "B" for TONE SELECT, press * or # to go up or down, and same is true when in VFO mode or in MEMORY mode. Tones 7, 8, and 9 mimic the three buttons at the top of the 733 mic.

Pressing "C" places the radio in cross band repeat mode. You will recognize this because of the dots between Kilohertz digits. After pressing "C", put the radio back into standby mode with "A#". The 733 will now cross band repeat. To disable cross band repeat, place the radio back into the External DTMF Remote Control with "Axxx#". If you can read through the lines, the 733 is capable of operating as a frequency agile remote base. Now Kenwood just needs a CW IDer!

This modification is read 1107 times.

[top of page](#)

24-01-1999

(TM-733) TM-733 data pinouts descriptions

- o o
- o o
- o o

On the booklet it says

1 = pkd packet data input transmit data frm tnc to transceiver.

2 = de ground for pkd.

3 = pks packet standbye tnc can use this pin to inhibit the the transceiver microphone input while transmitting packet signals.

4 = pr9 detects 9600 bps data (500 mvp-p/10 kohms).

5 = pri detects 1200 bps data (300mvp-p/10kohms).

6 = sqc squelch control output inhibits tnc data transmit while transceiver squelch is open.

Prevents interference to voice communications on the same frequency. also prevents retries. output level

open squelch: +5 v (high)

closed squelch: 0v (low)

I bought a baycom board,ive tried to put the baycom boad 5 pin din plug to this but faild so far on one attempt,if you are very good with the practical side of radio's could you please tell me the proper way to wire my kenwood tm 733e up the the baycom.

73 - MIKE, 2E1FCG @ GB7SYP

This modification is read 1170 times.

[top of page](#)

23-04-2000

(TM-733) TM-733A PL tone bleed through

Author: Kenwood Communication, inc.

Service Bulletin no. 1061 (16 September 1994)

Symptom:

When transmitting a PL tone a "humming noise" might be heard coming from the internal speaker of the TM-733A. This caused by a difference of potential between the tone generating circuit and the AF amplifier circuit.

Countermeasure:

This symptom is corrected by tying the ground connections in the AF amplifier and Tone generating circuit together.

Parts required:

Qty	Description	Old part No.	New Part No.
2	Screw	N87-2606-46	N87-2608-46
2	star washers		N16-0026-46
1*	Small gauge hookup wire		

Procedure:

1. Disconnect the power cable, microphone and antenna's etc.

2. Detach the front panel and set it aside.
3. Remove the top and bottom covers.
4. Remove the speaker and speaker mounting bracket.
5. Disengage the plastic front panel from the main chassis.
6. Remove the two Phillips head screws that secure the TX/RX unit to the chassis.
7. Install the new screws and star washers.
8. Solder a jumper wire from the ground side of C424 and pin number 8 of IC7 as shown in the accompanying illustration.
9. Reverse steps 1 - 5 for reassemble.

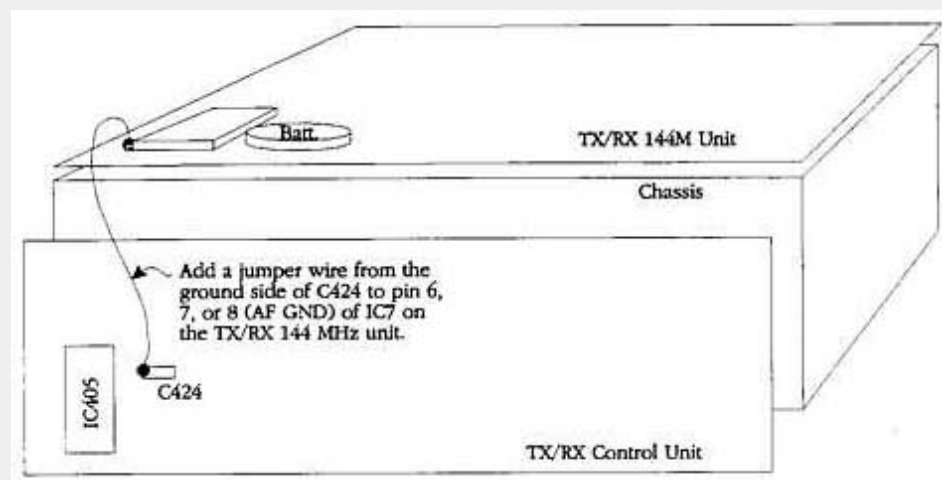

Caution: This modification requires soldering equipment rated for CMOS type circuits. It also requires familiarity with surface mount soldering techniques. If you do not have the proper equipment or knowledge do not attempt this modification yourself. Seek qualified assistance from your closest Kenwood Service Center (Long Beach, CA, or Virginia Beach, VA).

Time required for this modification is 30 minutes or less.

This modification is read 1101 times.

[top of page](#)

18-11-2001

(TM-733) TM-733 quick operation guide

Author: Frank, ZP5FGS - fgs@conexion.com.py. MODIFICATION.NET

Tired of carrying the operation manual in my car while operating my TS-733 A, I decided to make a "One Page Reference Manual" with almost all info needed.

Operating the 733 on a "not every day basis" without the manual is not easy because some settings do not follow a logic sequence, as you find it for example in Icom or others, and you may forget them.

The 733 is very rich in features and different settings, so it's a good advise to carry the Op. Manual with you, or at least have a short version like this.

The One Page version is an [Microsoft Excel file](#).

73 de Frank, ZP5FGS

This modification is read 1103 times.

[top of page](#)

19-07-1998

(TM-741) Umbau des TRX Kenwood TM-741 E fuer 9600bd

de DL1OBO @ DKOMAV.NDS.DEU.EU

Ich hatte ja schon mehrere FM-Geraete fuer 9k6 in Betrieb, aber mit dem TM-741 E ging es am besten !!!

Mir ist es gelungen den TM741 E für 9600bd zunutzen, und von Umbau kann eigentlich auch nicht die Rede sein, denn Umgebaut wird nichts.

Bei mir und mit DB0SHG klappt es ufb, auch mit DB0FD (was ich nur im Rauschen aus der City von Hameln höre geht es super.....

Beim Umbau bitte ich mit besonderer Vorsicht an den SMD-TRX heranzugehen. Für Schäden die aus diesem Beitrag entstehen übernehme ich keine Haftung !

Verwendetes Modem: TNC2C mit 9,8 Mhz und G3RUH-9k6 -Modem

Prinzipiell: Bei 9600bd wird die 9k6 NF-in/out im TRX abgegriffen.

ACHTUNG :

Der 741 sollte UNBEDINGT SPANNUNGSFREI sein !!!

1. Mann oeffne den TM741 vorsichtig !!!

Indem man beide Deckel entferne und das Bedienteil beiseite legt . Dann entfernt man die 70cm Unit (TX-RX UNIT/440M), und legt Sie vorsich auf den Tisch.

Dann das Abschirmblech entfernen.

NUN NUR KEIN ANGST HI, denn es ist nicht so wild wie es aussieht.
ABER VORSICHT IST GEBOTEN !!!

2. Abgriff der NF am DISKRIMINATOR

Das 9k6 RX-Signal wird unmittelbar am Pin 12 des IC 1 (KCDO4) abgegriffen. Mit der Abschirmung geht man auf Pin 16. Man loete am besten auf der Platinenseite !

3. Einspeisung des 9k6 TX-Signal....

So, die NF vom G3RUH wird zwischen VR2 & C 40 eingespeisst. Das war es nun fast schon....

Die beiden abgeschirmten Kabel habe ich nun aus der vorgesehenen Oeffnung (die mit einer Gummikappe abgedeckt war) nach draussen gefuehrt, und mit einer Diodenbuchse versehen.

Die PTT habe ich an der Mikebuchse abgenommen.

4. So, nun kommen wir zum Abgleich:

Ich setze vorraus, dass Tnc, Modem und TM 741 E richtig verdrahtet sind.

RX, TX und Masse aus der 5 Poligen Diodenbuchse, PTT wie gewohnt aus der Mikrofonbuchse.

a) Das Potis von G3RUH ganz zudrehen (höchsten Widerstand einstellen.) Also 0 Volt USS

Bei mir geht es am besten, wenn alle Jumper vom G3RUH (JMP 1-4) entfernt sind.

Wenn Ihr nun mitlesen können ist die halbe Miete gewonnen!

b) Nun der Sendeabgleich.

Ein Kontrollempfänger (Handy) leistet dazu wertvolle Dienste. Ich habe es auch ohne Oszilloskop hinbekommen.

Nun auf Monitor-Kanal schalten und TX-Dealay auf 120, damit der Sender schoen lange hochgetastet wird.

Drueckt man nun Return, ist in Kontrollempfaenger nur der Traeger zuhoeren. Nun das Poti von G3RUH Millimeterweise aufdrehen, bis das 9k6 Rauschen zuhoeren ist.

c) Nun in die nächste Mailbox. Aber erstmal TX-Dealy ZURUECKSTELLEN, bei mir geht es mit TX-Delay 15 noch gut. Aber da muss man etwas PROBIEREN !

Dort eine grosse Rubrik ablisten lassen. Dieses Listen muß EINWAND- FREI funktionieren !!!!

Wenn der Digi die Listingnummern 2..3 mal wiederholt, ist dies nicht OK ! Mit den JMP 1-4 etwas probieren bei mir geht es ohne Jumper am besten, evtl. kann es auch an den TNC-Parametern liegen.

Meine für DB0SHG & DB0FD : W 15 T 15 P 64

Evtl. mit den Parametern spielen....

d) SO, DASS WAR ES EIGENTLICH SCHON. Viel Spaß beim Umbau...

Ich arbeite nun schon ca. 14 Tage mit dem TM741 E in 9k6, und es geht ueber DB0SHG und DB0FD ohne FEHLER...

So liebe 9k6 Freunde, sollten noch spezielle Fragen auftreten, dann schreibt mir ruhig. Auch ueber Verbesserungsvorschlaege wuerde ich mich freuen..... Eine gute Hilfe bei der ganzen 9k6 Geschichte ist das Buch vom DG3RBU 9600-Bd FSK-Technik nach G3RUH-Standard..

Denn man lernt immer wieder etwas dazu

vy,73 aus Hameln an der Weser Andreas / DL1OBO @ DK0MAV DEU.EU

=====

From: DL6RDS @ DBORGB.BAY.DEU.EU

Hallo TM 741-E Freunde,

Seit ein paar Tagen bin ich in 70 und 23cm mit dem 741er in 9600BD QRV.

Ich habe mich bei dem Umbau, besser gesagt beim anzapfen, der RX und TX Leitungen in 70cm genau an den Vorschlag von DL1OBO gehalten.

(siehe unter den Board Kenwood in den Mailboxen) In 23cm ist das anzapfen aber genauso unproblematisch...

Eine kleine Sache noch voraus !

Für Schäden die aus diesen Beitrag entstehen }bernehme ich keine Haftung!!!

Die ganze Sache ist aber f}r einen Bastler kein Problem.

Bei mir funktioniert das ganze recht gut !

Umbau der 1200M TX-RX Unit

1. Abgriff der NF (RX) am DISKRIMINATOR

Das 9k6 RX-Signal wird unmittelbar am Pin 12 des IC 2 (KCDO4) abgegriffen. Mit der Abschirmung geht man auf den Pin 16 des IC 2. Diesen Punkt kann man am besten auf der Platinenseite erreichen!

2. Einspeisung des 9k6 TX-Signals an VCO PLL

Die NF vom G3RUH wird zwischen VR3 (MAX DEV) und R47 eingespeist. In 23cm ist der Einspeisepunkt bei mir vor dem Poti VR3, da sonst der Sender vom 741er nicht die Zeit die man durch ein langes TX-Delay zum probieren einstellt hochgetastet wurde!! Ich habe diesen Punkt direkt an einem Abgriff des Poti VR3 ange- l|tet. Das Poti VR 3 ist auf der Best}ckungsseite des 1200M RX-TX (lage siehe Skizze).

3. PTT Leitung

Die PTT-Leitung habe ich vorne an den 8-Poligen Modular Plug vom Mikrofon angezapft (L|tpunkt Platinenseite).

...so das wars dann schon f}r das Anzapfen am 23cm Modul!

Der Senderabgleich usw ist genauso wie bei dem 70cm Modul. Andreas DL1OBO hat in seiner Umbaubeschreibung dazu schon alles leicht und verst}ndlich beschrieben.

4. Skizze

23cm Modul (auf die Best}ckungsseite geschaut)
=====

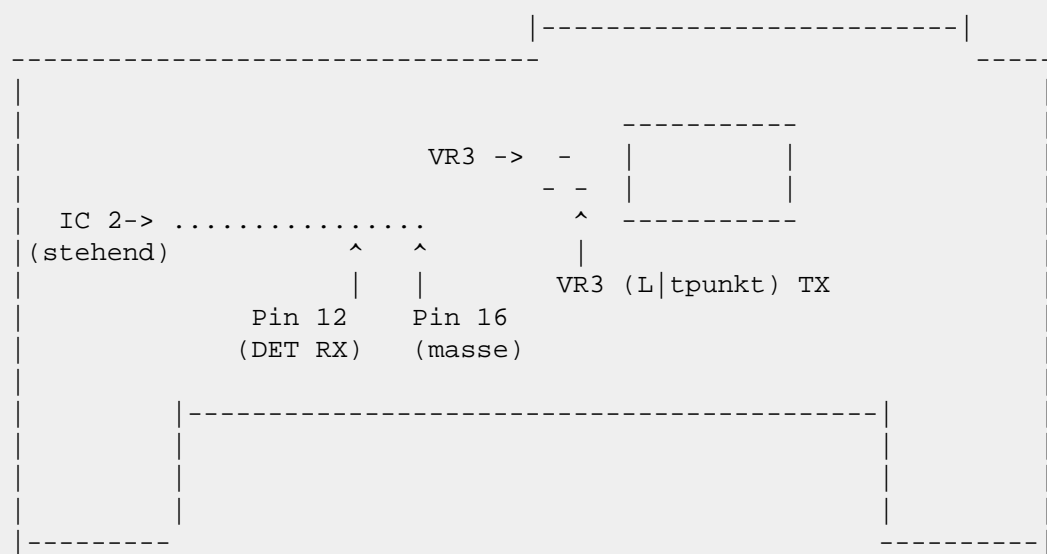

Bei den anbringen der RX-Leitung ist zu beachten das diese am besten an der Platinen-Seite angel|tet wird!! Im Bild oben sieht man die Best}ckungsseite !!

Ich hoffe die Skizze ist eine kleine Hilfe!! Ich }bernehme aber keine Garantie f}r die Richtigkeit!!

Anmerkung

Nach den "Umbau" ist zeitaufwendigste Arbeit das ausprobieren der Jumper F1-F4 am G3RUH Modem. Bei DL1OBO funktionierte es am besten wenn alle Jumper geöffnet waren.

Ich benutze den TNC 2H von Landolt Computer (1200/9600BD umschaltbar).

Bei mir funktionierte es bei folgenden Einstellungen am besten!!

TNC: G3RUH Modem Jumper 1,2 offen und Jumper 3,4 geschlossen

TNC-Parameter: TX-Delay ab 20 (741er schaltet etwas träge)

T=20 , P=255 , W=10

Mit den Parametern und den Jumpern müsst ihr die beste Stellung herausgefunden werden damit keine Pakete ständig wiederholt werden. Am besten probiert man das ganze mit einer geduldigen Gegenstation.

Besonderen Dank an dieser Stelle an Christian, DL5RL mit deren Hilfe (Gegenstation in 70+23cm) ich die ganzen Tests wunderbar durchführen konnte.

Also viel Spaß beim "Anzapfen" der 9k6 Leitungen.

73 de Michael aus Regensburg JN69BA via DB0RGB

This modification is read 760 times.

[top of page](#)

19-07-1998

(TM-741) TM-741ATE Frequency union

Phase 1

- Slide the release knob on the front panel to the right and remove the panel (be careful with the cable between the panel and the main unit.)
- Cut the green wire located in the left side (tape the bare ends of the wire to prevent shorts.)
- Switch the power on (a melody sounds to confirm the change.)

Phase 2

- Unplug the connectors of the cable between the panel and the main unit.
- Remove the two screws on the rear of the panel and open the rear of the case.
- On the left side of the lithium battery there are four jumpers marked R54, R51, R52 and R57 corresponding respectively to b0, b1, b2 and b3 bits described below. Set the four bits as required for your country:

- European Countries:

mode 5

b3 = 0

b2 = 1

b1 = 0

b0 = 1

- USA, Canada and Asia:

mode 0-3

b3 = 0

b2 = 0

b1 = 1

b0 = 1

WARNING: 0 => jumper , 1 > no jumper.

- Refit the rear of the case by reversing the order of disassembly.

Frequency range after modification (*)

unit	rx range		tx range		SHIFT			
	min	max	min	max	EUROPE	USA	CAN	ASIA
28	18	54	26	45	+/- 100 KHz			idem
50	40	90	46	76	+/- 1 MHz			idem
144	118	174	136	174	+/- 600 KHz			idem
220	215	260	215	235	+/- 1.6 MHz			idem

430	410	470	410	470	+/-1.6, -7.6	+/- 5 MHz
1200	1100	1400	1100	1400	+35, -6 MHz	+/-12, -20MHz

This modification is read 868 times.

[top of page](#)

19-07-1998

(TM-741) TM-741a/e AM recleppion with 28 and 50 mhz unit

- Press the F key, then press BELL; key within ten seconds. An A is displayed at the hundred-MHz position to indicate AM mode.
- To rr to FM mode press the F again, then press the BELL; within ten seconds

This modification is read 764 times.

[top of page](#)

19-07-1998

(TM-741) TM-741 A/E 900 MHz band receptton with 430 MHz unit

To change to the 900-MHZ band. select the 430-MHnd, then press and hold down the [MHz; key for at least a second. NOW 850.000 (initial setting) is displayed.

To return to the 430-MHZ band, press the [MHz] key again for at least a second.

Addling a secondary 900-MHz dedicated antenna at the 430-MHZ unit

- remove the power supply cable from the power supply or battery.
- remothe 430-MHz band unit with care.
For removal procedure see the instructionNAL - unit INSTALLATION, reversing the order of the procedure and... using the brain:
- Remove the shield plate (12 screws.)
- Solder a coaxial cable (0.8 d) to the input side of IC9 (center is aligned with the IC9, ground at right side.)
- Pass the cable through the notch and install the shield plate.
- Reassemble the main unlit.

This modification is read 827 times.

[top of page](#)

19-07-1998

(TM-741) TM-741A/E memory channel doubling

Each band can be switched to the normal memory C100 channels) and rear memory (100 channels). Each band can contain 200 channel and... yes, a total of 600 channels can De used for three bands

SORRY! This function can be enabled only by extending the receive frequency see bulletin #1 of this FREQUENCYEXTENSIoNSNEVERENDHISTORY.)

To switch the memory, hold down the F; key and press the rev; key:

Normal Memory 100 ch <--> Rear Memory (100 Ch)

The functions of the rear memory are the same as the normal memory, but memory channels are displayed as follows (rather than 01 to 00):

```

a1 -b0 ==01-10
b1-c0==11-20

c1- d0== 21-30
d1-eo==31-40

e1-f0==41-50
f1-g0==51-60

g1-h0==61-71
h1-i0==71-80

.l-j0==81-90

```

19-07-1998**(TM-741) TM-741A/E extended paging functions**

Preliminary

Cut the frequency extension jumper as described in Phase 1 of the bulletin #1.

Answer back function

Hidden function of the paging function.

If the answerback function is on, the code of the local transceiver is automatically transmitted to the other transceiver when the correct code is received to confirm the code has been received.

OPERATION

After the correct code is received, if there is no busy signal, the code of the local transceiver is automatically transmitted to the other transceiver.

ON/OFF To turn the answer-back on and off, hold down the
F; key and press then the Call key.

Automatic release function

Hidden function of the paging function.

OPERATION

If the automatic release function is on, paging is terminated automatically when transmission ends after a call is received.

ON/OFF To turn the function on and off, hold down the
[F; key and press then the jSHIFT; key.

19-07-1998**(TM-741) TM-741/E DTE DISPLAY Format**

The normal date format is YEAR-MONTH-DAY. It can be changed to YEAR-PAY-MONTH.

1. Remove the front panel and locate R60 and R61
(Where is Holmes?)
2. Move R61 (that is below R60) to the left.
3. Repack the front panel with care.

19-07-1998

(TM-741) TM-741A/E DC ERDISPLAY

Make the following change to display the sb line voltage on the? memory channel section when the tieis displayed.

1. Remove the front panel and loca R60 and R61
Where is Holmes?)
2. Move R60 That is above R61) to the left.
3. Repack the front panel with care.

Since the voltage of the Sb line to the panel is displayed, it changes due to the loss caused by the wie nd connctor

This modification is read 742 times.

[top of page](#)

19-07-1998

(TM-741) TM 741A/E headlight linkage dimmer

Make the following change to reduce the dimmer level by one step when the headlight is turned on (d4 remain unchanged).

1. Install DTC144EK on the panel printed circuit board (below R60 and R61
2. connect the load from the ILUMI pin of the panel printed circuit board to the 12 V side Where 12 V is output whene light is turned on) of the position light of the car.

This modification is read 753 times.

[top of page](#)

19-07-1998

(TM-741) TM 741A/E game mode

Simple me, such as a roulette game and a shooting game, and music can be played using the frequenay display.

To enter game mode, hold down the F] key and the MUTE key, and switch the power on.

1-2-3 is shown on the display, band SEL A; selects Roulette, BAND SEL B; selects Shooting, and jBAND SEL C; selects Music.

To return to game selection mode, press the VFO] key.

To exit game mode, press the microphone key or switch power off.

Roulette Game

* When the roulette game starts, the display shows [000], the transceiver enters the receive mode with the power on, and th three digis bein to rn raidly.

, Wen the MUTE key is pressed, [000 on the display can be changed: BAND SEL A; stop the leftmost digit, BAND SEL B; stops the middle digit, and BAND SEL C] stops the rightmost digit. Other keys are not accepted.

A if the three digits match, the LED and illumination lamp flash and sound effects are produced.

* if 1231 ;E displayed, a fanfare sounds. If the MUTE; key is pressed game mode is exited and the transceiver functions normally.

Shooting game

* When the shooting game starts, your score is shown in display: section A, and cannon balls, target and remaining cannons are shown in display section C, starting from the left.

A If the LOW; key is pressed, the game starts. The "number" attacks from the left of display 8. Take aim at the enemy "number" with the [TONE; key key, and shoot with the [mute key. You win if 16 enemies are shot per screen. Thirty cannon balls can he used per screen. Each time you clear a screen, the speed increases. If eight screens are cleared, the first screen returns. The process is repeated.

When the music feature is selected, ENJOY SOUND PLAY; is displayed and the following tones can be produced:

MR = A
KHz = A#
CALL - B
F = c
BELL = C#
TONE = D
REV = D#

BTSS = E
MUTE - F
CSCL A = F#
BSEL A - G
CSRL B = G#
BSEL B = A
CSEL C = A@
BSEL C = B

This modification is read 765 times.

[top of page](#)

19-07-1998

(TM-741) Kenwood TM-741a GAME Dox

Introduction:

There are actually three GAMES "hidden" on the Kenwood TM-741a Multiband Transceiver. These are UNDOCUMENTED and I'm not exactly sure who originally found these games??.. (I came across a brief description of these hidden games on rec.radio.amateur.misc on UseNet, but no one had the complete original Post!)

How to access "Game Mode":

- 1) Turn OFF the TM-741a.
- 2) Hold the [F] + [MUTE] and turn ON the TM-741a.

(You should see: -1- -2- -3- on your display, you're now in "Game Mode"!!)

- 3) Select the Game you wish to play by hitting the appropriate Band Select Button. (-1- = Band Sel 1 ; -2- = Band Sel 2 ; -3- = Band Sel 3)

-1- ==> SLOT MACHINE Game

-2- ==> SPACE INVADERS Game

-3- ==> MUSICAL KEYBOARD

NOTE!

The [VFO] will always exit you to the Main Game Menu (-1- -2- -3-).. The [MUTE] will normally Start the Game.

Game #1: SLOT MACHINE:

To play... Hit [MUTE] to start the numbers tumbling. Starting from the left and proceeding to the right, hit the Band Select Buttons to stop each number! If you don't get a 3-in-a-row match, the radio plays a sound and the game is over. ([MUTE] to play again). If you match 3-in-a-row, then...well I won't spoil it for you!.. (It's neat!!)

Remember; [VFO] to return to the Game Menu.

Game #2: SPACE INVADERS:

The Display... You will see the following display:

000000 ----- 0-0

(Score) (Invaders) (Selected Number - Number of Lives Left)

To play... Hit the [LOW] key to begin. The radio will then put a random number from 0 - 9 in the first position in the dashes.. (4-----) you must then use the [TONE] key to select the number the radio selected and then quickly hit the [MUTE] key to "fire" it. The number will then disappear and a new one will appear!.. If you don't act fast, the number will move to the second dash and another random number will appear, (84----).. If you're not keeping up, eventually the numbers will reach then last dash line and you will lose a life!!.. (Once all lives are lost, the game is over!) Also, you must "destroy" 30 numbers before moving onto the next round!.. Each round will start getting faster and faster!!.. So be prepared!! (It really gets TOUGH!!) All throughout the game it will keep score of how many "hits" you made.. (I believe it's 10 points a hit, I think!)..

Remember; Hit [VFO] to return to Game Menu.

Game #3: MUSICAL KEYBOARD:

I don't think this is actually a "Game"??.. What I've been able to figure out is that when you select this "game" the following message appears on the display: Enjoy Sound Play

At this point, the whole keypad on the face-plate of the TM-741a is a "Musical Keyboard"!!.. Try it, hit any of the keys, Band Select Buttons; Cont Sel Buttons; [MUTE]; [TONE]; [MHZ]; Etc...etc..etc... (Except for the [VFO] key, that returns you to the Game Menu!)

19-07-1998**(TM-741) Display test**

Hold down F and MHZ while turning on power. This activates the display test mode where all segments and indicators are lit. Note the "ACC" indicator at the lower right. ACC is not defined in the manual, however I saw it come on once one night after I started the car with the radio turned on. The display lit up ACC and the UHF frequency display showed some sort of HEX code (a ROM checksum maybe?).

19-07-1998**(TM-741) Hearing birdies in the 440 MHz position**

Nov 91

Are you hearing "birdies" in the 440 MHz position on your new Kenwood TM-741A?

I've had the problem with mine, and have been talking with other people who are having the same problem. Kenwood couldn't duplicate the problem and returned my 440 deck. The problem appears either as weak wandering carriers, or intermods with other input signals. Seldom is the signal strength greater than S2, but the squelch stays open most of the time. K6DYD has traced the problem to instability in the RF front-end (Q1, Q2), which is electronically switch out of the signal path by IC8 when out-of-band frequencies are selected. The solution appears to be placing a 220-ohm 1/4-watt resistor from pin-10 of IC8 to ground--this damping in what appears to be a signal leakage path prevents the instability or parasitic oscillations causing the problem. He further observed that, if the control head is modified for full-frequency operation by removing the jumpers labeled R54 and R55, the RF preamp is continuously removed from the signal path unless the GREEN WIRE on the processor motherboard has been cut. During proper operation, pin-9 of IC8 should change state when tuning in-band vs. out-of-band.

The 220 MHz deck seems to enjoy having its VCO modulated by AC coming in the power cord. Alternator whine is annoyingly present during both transmission and reception. No cure identified yet.

For those of you that want 220-440-1200, simply remove the 144 module, move the power cable into another module, restuff the frame, restart while resetting the VFO limits... Works fine.

I would appreciate hearing from any of you having similar problems; writing to customer relations is also a good idea. If you're considering one of these units but don't want the 2M deck, also write Kenwood. I've lost count of people who said they wanted this option. I'd like to be able to get all the decks separately from the bare frame.

All in all, it's a nice radio--it just has growing pains; the sooner Kenwood owns up to the problems and fixes them, the more they'll sell.

-Bob Buaas K6KGS (Internet: buaas@nosc.mil) (Phone: 714/968-0070)

19-07-1998**(TM-741) TM-741A/E repeater modification (transponder functions)****WARNING:**

Extended continuous transmission may cause a failure of the equipment. See "transmission time limit" below.

Preliminary hardware modification

- a. Loosen the four screws on the side of the set.
Remove the four screws on the bottom of the set.
Remove the bottom of the case.
- b. Locate the two jumpers on the Control Unit, on the opposite side of the panel (see in figure, below.)

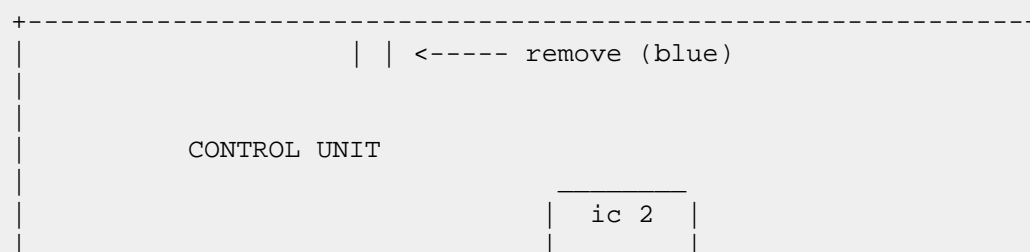

- c. Remove the blue chip jumper (0 OHM). Use a soldering iron with a thin tip in order not to damage other components or patterns.
- d. Refit the rear of the case by reversing the order of disassembly.

Fixed-band repeater operation

With the fixed-band repeater, the transmission band is fixed, and if a signal come in on the remaining band, and the BUSY turns on, the transmit mode is entered and modulation is done using the received signal.

- a. If the option band is present, turn off one of the three band.
- b. Set the frequencies of two bands (rx/tx split are also permitted.)
- c. Set a band as the transmission (PTT display) and operation (green indicator) band (press the band select key.)
- d. Hold down the [F] key for at least a second (the red led flashes), then press the [MUTE] key.

Cross-band repeater operation

When the cross-band repeater function is being used, a signal enters one of two bands. Busy turns on, the other band enters the transmit mode and modulation is done with the received signal.

- a. Set the frequencies of two bands (rx/tx repeater split are also allowed.)
- b. Set a band as the transmit band (PTT display) and the other as the operation band (green indicator). This arrangement can be reversed.
- c. Hold down the [F] key for at least a second (the red led flashes), then press the [MUTE] key. The dots on both frequency display flash, and the cross-band repeater works. Only reception is possible in the remaining band.

Dual-in repeater operation (when the option band is installed)

With the dual-in repeater, the transmit band is fixed, and if a signal comes in on one of the other bands, Busy turns on, transmit mode is entered and modulation is done using the received signal.

- a. Set the frequencies of all three bands.
- b. Set a band as the transmission (PTT display) and operation (green indicator) band (press the band select key.)
- c. Hold down the [F] key for at least a second (the red led flashes), then press the [MUTE] key. The dots on the frequency display light.

Turn-off repeater

To turn the repeater off, hold down the [F] key for at least a second (the red led flashes), then press the [MUTE] key. The state before setting returns.

Repeater transmission time limit setting

The repeater transmission time limit is set with the time-out timer (TOT). The time can be set to 3, 5, 10, 20, 30 minutes, or OFF. (See the item about the TOT of the main unit.)

Be happy and 73 de Antonello is0xse,
Cagliari, Sardegna, Italia, Europa... MONDO!!!!
ISOXSE @ IWOUHD.ITA.EU

22-08-1999

(TM-741) TM-741a All-Band mod for new Kenwood Tri-Bander

To enable FM transmit from 136-174, 410-470, do the following:

1. Remove the front panel.
2. Don't cut the green wire. If it is cut, splice it back.
3. Disconnect front panel unit cable.
4. Remove two screws in front panel back and remove rear cover.
5. Locate row of resistors next to Lithium Battery.
6. Remove R54 and R55 - clearly marked, the two nearest the battery.
7. Reassemble. No MPU reset necessary.

Note: Removing only R54 enables MARS/CAP only. Removing both enables all. -fred--

Fred Lloyd AA7BQ

Date: 09-12-1999

User comment

From: [Tony Bamberger](#)

Subject: Corrections

I have the following corrections to Fred's mods for the new kenwood TM-741a multi band radio...> Hot off the presses...>

```
> to enable FM transmit from 136-174, 410-470, do the following:>
> 1. Remove the front panel.
> 2. Don't cut the green wire. If it is cut, splice it back.
> 3. Disconnect front panel unit cable.
> 4. Remove two screws in front panel back and remove rear cover.
> 5. Locate row of resistors next to Lithium Battery.
> 6. Remove R54 and R55 - clearly marked, the two nearest the battery.
> 7. Reassemble. No MPU reset necessary.>
> Note: Removing only R54 enables MARS/CAP only. Removing both
> enables all.
```

This is not 100% correct. According to the mod sheets i have from kenwood, you have to cut the green wire and remove R54 for mars/cap mod.

For the DC-light mod, you resplice the green wire (if cut) and remove both R54 and R55.

One side note, no reset is needed as mentioned above, but it does wipe out the values stored in the vfo memories (at least on the radio's mod'ed around here). As long as we're talking mods...

For extended receive only other than the 144 & 440 (which are already extended) you only cut the green wire. This gives you 10 meter coverage from 18-54 mhz, 6 meter coverage from 40-90 mhz, 220 coverage from 215-260 mhz and 1.2 GHz coverage from 1100-1400 mhz.

Note that these only apply if the specific module is installed in the radio (i.e. 10 meter, 6 meter, 220 or 1.2 ghz)...

This modification is read 969 times.

[top of page](#)

19-07-1998

(TM-742) Microprocessor Change, TM642/742/942

Author: Kenwood Communication, inc.

Service Bulletin no. 1042 (28 March 1994)

This bulletin supercedes ASB-1033.

Symptom:

Reports of problems with microprocessor lock-up when using S-meter squelch, problems with storage/recall of PL tone frequencies of 203.5 Hz. and/or 114.8 Hz., or problems with a lack of transmit on the UHF band modules during Remote operation can be corrected using the changes noted in this bulletin.

Notes:

1. All TM-642A transceivers work fine and do not require any changes.
2. TM-742/942's that exhibit any of these symptoms with serial numbers between 412XXXX and 509XXXX need only change IC1 on X53-3460-21 B/2.
3. TM-742/942's that exhibit any of these symptoms with serial numbers of 412XXXX and below must also change IC1 on X54-3130-11.
4. TM-742's with serial numbers of 509XXXX and greater have had these changes incorporated in production.
5. Some TM-742's and TM-942's below serial number 509XXXX were returned to Japan for modification. If the unit that you have

has a black dot on the box near the serial number it has already been modified and requires no further action.

Parts Required:

Qty	Description	Old Part No.	New Part No.	Circuit Description
1	Microprocessor	HD6433388A07F	HD6433388A22F	IC-1
		or		
		HD6433388A14F		
1	Microprocessor	HD404719A26H	HD404719A32H	IC-1

Caution: This modification requires advanced surface mount soldering equipment that is rated for CMOS circuits. It also requires familiarity with advanced surface mount soldering techniques. If you do not have the proper equipment or knowledge do not attempt this modification yourself.
 Attempting to remove and replace either IC without the proper equipment and techniques can easily damage the circuit boards and void your warranty.
 Seek qualified assistance from your closest Kenwood Service Center (Long Beach, CA, or Virginia Beach, VA).

Time required for this modification is 90 minutes or less.

This modification is read 1092 times.

[top of page](#)

19-07-1998

(TM-742) Modification of TM-742 & 942

Open the lower panel of TM-742.

***** There are TWO version. Please check which version your rig is.*****

FRONT PANEL IS UPPER SIDE

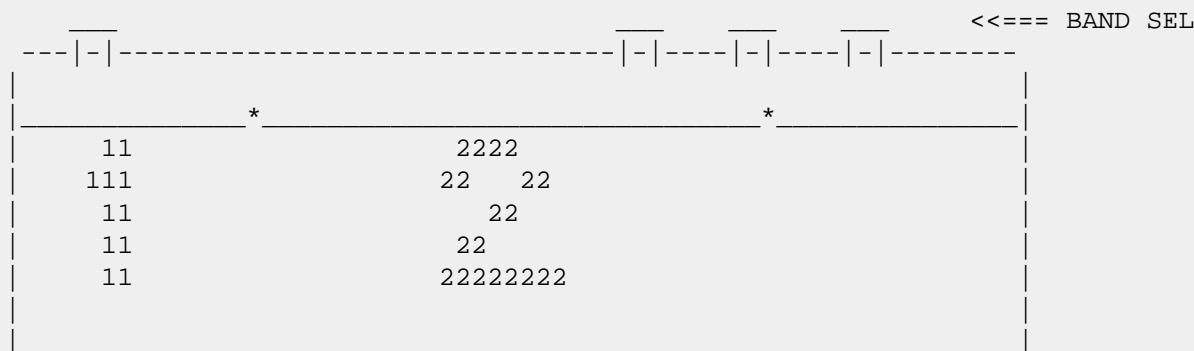

1. ***** FOR OLD VERSION *****
SEE THE POINT OF [2] .If you can find a small board masked with black sponge , your TM-742 is OLD VERSION.
2. On right side small board , there are three lines. Make short circuit with middle line and lower line.

1. ***** FOR NEW VERSION *****
SEE THE POINT OF [2] . If you can not find a small board , your rig is NEW VERSION.
2. SEE THE POINT OF [1] . There is a chip [2R7] . And below this chip [2R7] , there are small chip [473] .

[GRAPHIC IS FOR JA VERSION]

*_*_*_*_*_*_*_*_*_*_*

R R R X R = chip [473]

* * * * *

* * * * *

Make short circuit two X point.

X R

Maybe on your TM-742,there are chip [473]

*_*_*_*_*_*_*_*_*_*_*

with different patern. This graphic is for JA version. So please try until modification will succeed.

OPERATION

1. ON 144MHz press band sel more than 1sec . mode change AM <-> FM.
2. ON 430MHz ditto band change 430 <-> 870
3. ON 1200MHz ditto 1200 <-> 870
4. [F] + BELL -> repeater dual RCV.
5. 118-136MHz mode chang to am automaticaly.
6. X-band repeater operation. Select one band by [BAND SEL] select onother band by [CONT SEL]. Press [F] key more than 1sec. Press [MUTE] Key. X-band operation will work. Press [F] then [MUTE] key -> cancel X-band repeater operation.

19-07-1998

(TM-742) Extended frequency for TM-742E

Before open your TM-742E, be sure you have disconnect the power. Don't do this modifications if you hare not sure or if you have not the necessary knowledge in eletronics to do this !

Open the lower panel (see your User Manual for details)

You will have something who looks like that :

```

      I I          I I I I I I      <== Vol. & Squelch Boutton
-----
I   Here   I          I          I
I-----I   Control Unit          I
I          X53-346X-XX A/2          I
-----
```

You can find a range of CMS chip resistors who looks like that :

```

0      1
-----
# #    #-# Bit 0
#-#    # # Bit 1          # # mean no CMS Chip resistor
# #    #-# Bit 2          #-# mean CMS Chip resistor
#-#    # # Bit 3
#-#    # # Bit 4
# #    #-# Fan Delay Bit 0
# #    #-# Fan Delay Bit 1
# #    # # Repeater Bit
```

```

With bit 0 set to 1
bit 1 set to 0
bit 2 set to 1
bit 3 set to 0
bit 4 set to 0
```

You have the extended frequency on VHF from 118 to 174 MHz

You have the extended frequency on UHF from 410 to 470 MHz

You have the extended frequency on UHF from 800 to 1000MHz

On 144MHz, if you press MHZ Key more than 1 second, mode change AM<=>FM

On 430MHz, if you press MHZ Key more than 1 second, band change 430<=>870

Note that from 118 to 136MHz, the mode change automaticaly from FM to AM and you can see a "A" which replace the One hundred MHz (ex : A18.125MHz)

You have the repeater possibility (for more detail, see page 59 of your Kenwood Instruction Manual)

In fact, your TM-742E now as mostly the same functions that the TM-742A which is for the US market.

19-07-1998

(TM-742) Fan Delay time setting

The fan can be controlled by setting the chip resistor (R66 & R65, 47kHom) for fan delay bits 1 and 0 as follows :

FAN CONTROL	Fan Delay bit 1	Fan Delay bit 0
On when power is On	0	0
On during transmission	0	1
On during transmission and for 1 minute after trans. end	1	0
On during transmission and for 2 minutes after trans end	1	1

This modification is read 986 times.

[top of page](#)

19-07-1998

(TM-742) Wireless remote control with DTMF handheld transceiver

When you use the MC-45DME microphone, you can of course have the remote function which is explain in the Instruction Manual on page 61 "Remote Control by DTMF Microphone".
When you put the TM-742E in Remote Control mode by pressing more than 1 second the "F" key then the "RC" key, you can control some of the function with a Handheld DTMF like the TH-28E or TH-22...
It is not write in the Kenwood Instruction Manual how to use it. So I had some difficulty to find some of the possible remote functions.
If you find more of them, I will be happy if you told me about them.

This modification is read 965 times.

[top of page](#)

19-07-1998

(TM-742) CHANGE YOUR TM-742E TO A TM-942E (who don't exist on the market)

If you want to put the 1200MHz band unit, you simply refer to your Kenwood Instruction Manual and you have a display who looks like that :

```
-----  
| 1296.000 | 144.550 | 432.800 |  
-----  
|= 0 ##### . 0 0 0 |  
-----
```

This is not really convenient as the logique would be to have the 1200MHz display at the far right of the Transceiver.

So if you want to have something who looks like the TM-942A but with a TM-742E + 1200MHz band unit, just change the 144 and 430MHz band unit lower (refer to the Kenwood Instruction Manual page 94 and after, just like if you install an optional unit), then you will have this :

```
-----  
| 144.550 | 432.800 | 1296.000 |  
-----  
|= 0 ##### . 0 0 0 |  
-----
```

You can also change in anyway all of the band unit to have the 430MHz on the left, 144MHz on the right...etc... just imagine what you want to have.

This modification is read 1099 times.

[top of page](#)

28-03-1999

(TM-742) TM-742/942 Beyond Mars/CAP Mod. Guide

Procedure:

1. Detach the front panel from the main chassis.
2. Remove the bottom cover of the transceiver by removing the 4 screws on the bottom of the cover and loosening the 4 screws on the side of the unit.
3. Orient the radio so the bottom is up and the front panel area is near your chest. Near the front panel area you will find a large board, this is the control unit.
4. Remove the chip resistors "Y" noted in the diagram below, and reinstall them in position "Z" as shown.
5. Reinstall the bottom cover of the transceiver and reattach the front panel.
6. Reset the microprocessor. Press and hold the MR key while the power is switched on. Then release the MR key. This will erase all operator programmed data.
7. The frequency range after modification will be:

28 Mhz Band:	RX:	18.0 thru	54.0 Mhz
	TX:	26.0 thru	45.0 Mhz
50 Mhz Band:	RX:	40.0 thru	90.0 Mhz
	TX:	46.0 thru	76.0 Mhz
144 Mhz Band:	TX:	136.0 thru	174.0 Mhz
220 Mhz Band:	RX:	215.0 thru	260.0 Mhz
	TX:	215.0 thru	235.0 Mhz
440 Mhz Band:	TX:	410.0 thru	470.0 Mhz
1.2 Ghz Band	RX/TX:	1100.0 thru	1400.0 Mhz

Please note that these are theoretical ranges only. Not all radios will be capable of tuning the entire range.

Control Unit X53-346X-XX A/2

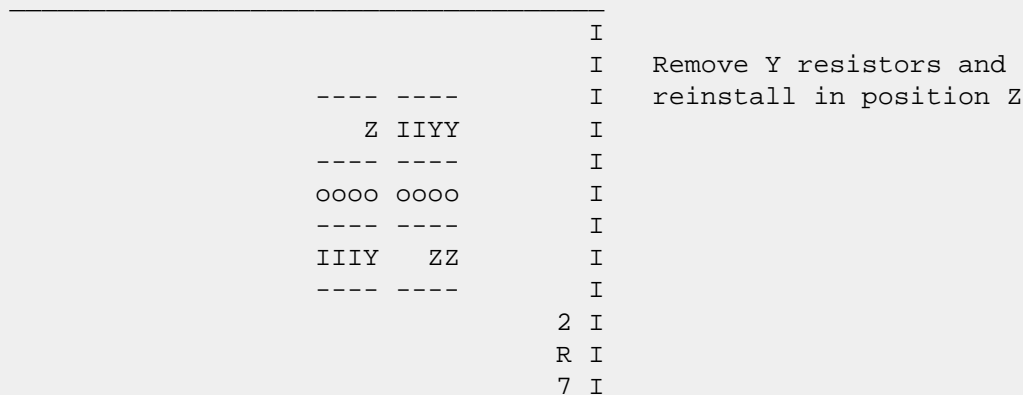

This modification is read 1104 times.

[top of page](#)

23-04-2000

(TM-742) TM-742/942 28 MHz/50 MHz RC TX failure

Author: Kenwood Communication, inc.

Service Bulletin no. 1029 (29 June 1993)

Symptom:
 During RC operation (remove Control) the 28 MHz and 50 MHz modules do not transmit after a frequency within the affected band is entered from the microphone keypad. Pressing the PTT key will cause a beep to be sounded but the radio will not transmit. This error is a result of a programming error in two of the microprocessors.

Corrective action:
 Replace IC1 on the Control unit X53-3460 B/2 and IC1 on the Display unit X54-3130 A/3 to correct this symptom:

Parts required:

Qty	Description	Kenwood Part No.	Circuit description
1	Control unit microprocessor	HD6433388A07F	IC1
1	Display unit microprocessor	HD404719A32H	IC1

Note:
 To activate the RC function after changing these two parts you need only press the RC key on the font panel of the radio. This method differs from the original method which required use of the "F" key and the "RC" key.

Caution: This modification requires soldering equipment rated for CMOS type circuits. It also requires familiarity with surface mount soldering techniques. If you do not have the proper equipment or knowledge do not attempt this modification yourself. Seek qualified assistance.

Time required for this modification is 1.5 hour or less.

This modification is read 977 times.

[top of page](#)

23-04-2000

(TM-742) TM-742/942A Microprocessor change

Author: Kenwood Communication, inc.

Service Bulletin no. 1033 (29 November 1993)

Symptom:

Reports of problems with microprocessor lock-up when using S-meter squelch, problems with storage/recall of PL tone frequencies of 203.5 Hz. and/or 114.8 Hz., or problems with a lack of transmit on the UHF band modules during Remote operation can be corrected using the changes noted in this bulletin. Units that exhibit any of these symptoms with serial numbers between 412xxxx and 507xxxx need only change IC 1 on X53-3460-21 B/2. Units that exhibit any of these symptoms with serial numbers of 412xxxx and below must also change IC1 on X54-3130-11. Units with serial numbers of 507xxxx and greater have had these changes incorporated in production.

Parts required:

Qty	Description	Old part No.	New Part No	Circuit desc.
1	Microprocessor	HD6433388A07F		
		or		
		HD6433388A14F	HD6433388A22F	IC1
1	Microprocessor	HD404719A26H	HD404719A32H	IC1

Caution: This modification requires advanced surface mount soldering equipment that is rated for CMOS circuits. It also requires familiarity with advanced surface mount soldering techniques. If you do not have the proper equipment or knowledge do not attempt this modification yourself. Attempting to remove and replace either IC without the proper equipment and techniques can easily damage the circuit boards and void your warranty. Seek qualified assistance from your closest Kenwood Service Center (Long Beach, CA, or Virginia Beach, VA).

Time required for this modification is 90 minutes or less.

This modification is read 976 times.

[top of page](#)

23-04-2000

(TM-742) TM-642/742/942A Microprocessor change

Author: Kenwood Communication, inc.

Service Bulletin no. 1040 (10 February 1994)

Symptom:

Due to a recent rule change by the FCC it is no longer possible to supply transceivers, or provide replacement microprocessor that would allow a transceiver to receive in the 800 MHz band.

Corrective action:

The microprocessor program of IC5 has been modified to prevent 800 MHz band reception. Production has been changed beginning with serial number lot 510xxxx. Units produced after this point will not be capable of 800 MHz reception.

Parts required:

Qty	Description	Old part No.	New Part No
1	Microprocessor	HD6433388A22F	HD6433388A25F

Procedure:

When ordering a replacement microprocessor you will be supplied with the new version. Please make sure your customer understands the limitations of this new

This modification is read 933 times.

[top of page](#)

25-11-2000

(TM-742) TM-742 Control Unit X53-346X-XX ** B/2 TX Mod**

Procedure:

1. Remove the bottom cover of the transceiver by removing the 4 screws on the bottom of the cover and loosening the 4 screws on the side of the unit.
2. Orient the radio so the bottom is up and the front display is near your chest. Near the front display area you will find a metal cover over the a section of the board, remove the two screws that hold it down in front It will now be necessary to bend the metal cover up to gain access.
3. Locate the grouping of 473 chip resistor pads on the right, above the chip labeled 2R7. This is what the [473] chip resistors grouping look like:

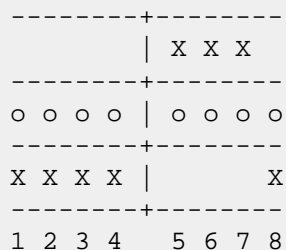

Here is what I have read pertaining to the TM-742 w/ Control Unit X53-346X-XX *A/2*

Old version mod, per JP1LRT & N8QXP:

Make a short circuit with middle line and lower line on all pads New version mod, per JP1LRT & N8QXP:

Short the upper part of pad 8, & the lower of pad 5.

Universal mod TM-742/942, per VE2PAL:

Move the [473] chip resistor on pad 4 up, & chips 7 & 8 down.

None of these worked for me with the B/2 contol head.

So I figured this out myself.

Short the lower part of pad 7. No need to reset the radio, it does that automatically. Note the automatic repater offset will be disabled.

After the mod:

28 Mhz Band:	RX:	18.0 thru	54.0 MHz
	TX:	26.0 thru	45.0 MHz
50 Mhz Band:	RX:	40.0 thru	90.0 MHz
	TX:	46.0 thru	76.0 MHz
144 Mhz Band:	RX/TX:	136.0 thru	174.0 MHz
220 Mhz Band:	RX:	215.0 thru	260.0 MHz
	TX:	215.0 thru	235.0 MHz
440 Mhz Band:	TX:	410.0 thru	470.0 MHz
1.2 Ghz Band	RX/TX:	1100.0 thru	1400.0 MHz

Please note that these are theoretical ranges only. Not all radios will be capable of tuning the entire range.

This modification is read 1048 times.

[top of page](#)

19-07-1998

(TM-941) Kenwood TM-941A undocumented feature

Documentation follows....

This modification is not really a modification, but an undocumented feature that Kenwood Corporation has no record of.

This modification has not been completely tested, so those who feel brave enough to try this out are welcome to it, but I am not responsible for any ill-effects as a result of utilizing this feature.

What this feature offers to the end-user is an extremely powerful feature: doubling your memory capacity. With the Kenwood TM-941A, the radio has ONE VFO, ONE CALL, and 100 memory positions that are labelled 00 thru 99. This feature offers the user another 100 memory positions PER BAND!!!

How to perform this undocumented feature:

1. Have the radio turned on.
2. Press F and REV simultaneously.
3. Memory position A1 will show; this memory position cannot be eliminated thru the MR/F function.

4. Work the VFO in a similar manner that you would with the radio in normal mode.
5. When you save the memory position, take a look around at the layout of these memory positions -- the memories are labelled hexidecimally; that is, they are labelled AA thru A9, B0 thru B9 until you have reached J9. J9 is the 100th position in this alter memory area.
6. When you are finished, just press the F and the REV buttons simultaneously, and you are back in the normal memory area.

As stated before, this feature has been found to be static in nature; that is, when the power is turned off, the memory positions are still retained and do not interfere with the original memory area. Mind you, this memory feature has not been completely tested, SO BE EXTREMELY CAREFUL! I ASSUME NO LIABILITY FOR FINDING THIS FEATURE SINCE I AM DOING THIS AS A BENEFIT TO AMATEUR RADIO!

BTW, Kenwood does not have any records and/or any comments regarding this feature. I suspect that this feature is for diagnostic purposes and should be treated as such. Forewarned is forearmed!

This modification is read 337 times.

[top of page](#)

19-07-1998

(TM-942) Microprocessor Change, TM642/742/942

Author: Kenwood Communication, inc.

Service Bulletin no. 1042 (28 March 1994)

This bulletin supercedes ASB-1033.

Symptom:

Reports of problems with microprocessor lock-up when using S-meter squelch, problems with storage/recall of PL tone frequencies of 203.5 Hz. and/or 114.8 Hz., or problems with a lack of transmit on the UHF band modules during Remote operation can be corrected using the changes noted in this bulletin.

Notes:

1. All TM-642A transceivers work fine and do not require any changes.
2. TM-742/942's that exhibit any of these symptoms with serial numbers between 412XXXX and 509XXXX need only change IC1 on X53-3460-21 B/2.
3. TM-742/942's that exhibit any of these symptoms with serial numbers of 412XXXX and below must also change IC1 on X54-3130-11.
4. TM-742's with serial numbers of 509XXXX and greater have had these changes incorporated in production.
5. Some TM-742's and TM-942's below serial number 509XXXX were returned to Japan for modification. If the unit that you have has a black dot on the box near the serial number it has already been modified and requires no further action.

Parts Required:

Qty	Description	Old Part No.	New Part No.	Circuit Description
1	Microprocessor	HD6433388A07F	HD6433388A22F	IC-1
		or		
		HD6433388A14F		
1	Microprocessor	HD404719A26H	HD404719A32H	IC-1

Caution: This modification requires advanced surface mount soldering equipment that is rated for CMOS circuits. It also requires familiarity with advanced surface mount soldering techniques. If you do not have the proper equipment or knowledge do not attempt this modification yourself.

Attempting to remove and replace either IC without the proper equipment and techniques can easily damage the circuit boards and void your warranty.

Seek qualified assistance from your closest Kenwood Service Center (Long Beach, CA, or Virginia Beach, VA).

Time required for this modification is 90 minutes or less.

This modification is read 477 times.

[top of page](#)

19-07-1998

(TM-942) Modification of TM-742 & 942

pen the lower panel of TM-742.

***** There are TWO version. Please check which version your rig is.*****

FRONT PANEL IS UPER SIDE

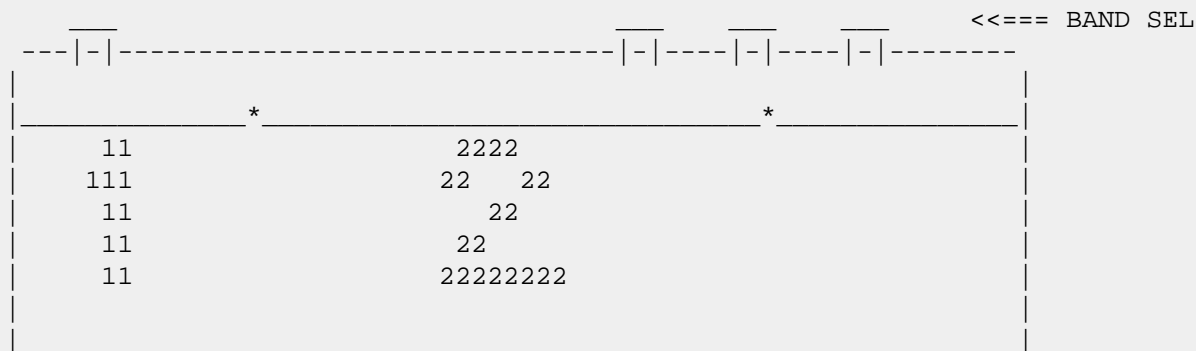

1. ***** FOR OLD VERSION *****

SEE THE POINT OF [2] .If you can find a small board masked with black sponge , your TM-742 is OLD VERSION.

2. On right side small board , there are three lines. Make short circuit with middle line and lower line.

1. ***** FOR NEW VERSION *****

SEE THE POINT OF [2] . If you can not find a small board , your rig is NEW VERSION.

2. SEE THE POINT OF [1] . There is a chip [2R7] . And below this chip [2R7] , there are small chip [473] .

[GRAPHIC IS FOR JA VERSION]

*_*_*_*_*_*_*_*_*_*_*_*

R R R X

R = chip [473]

* * * * * * * * * * * *

* * * * * * * * * * * *

Make short circuit two X point.

X R

Maybe on your TM-742,there are chip [473]

*_*_*_*_*_*_*_*_*_*_*_*

with different patern. This graphic is for JA version. So please try until modification will succeed.

OPERATION

1. ON 144MHz press band sel more than 1sec . mode change AM <-> FM.
2. ON 430MHz ditto band change 430 <-> 870
3. ON 1200MHz ditto 1200 <-> 870
4. [F] + BELL -> repeater dual RCV.
5. 118-136MHz mode chang to am automaticaly.
6. X-band repeater operation. Select one band by [BAND SEL] select onother band by [CONT SEL]. Press [F] key more than 1sec. Press [MUTE] Key. X-band operation will work. Press [F] then [MUTE] key -> cancel X-band repeater operation.

73s DE JP1LRT @ JL1YVX.10.JNET1.JPN.AS
YOSHIHARU "KEI" TSUKUURA

This modification is read 500 times.

[top of page](#)

28-03-1999

(TM-942) TM-742/942 Beyond Mars/CAP Mod. Guide

Procedure:

1. Detach the front panel from the main chassis.
2. Remove the bottom cover of the transceiver by removing the 4 screws on the bottom of the cover and loosening the 4 screws on the side of the unit.
3. Orient the radio so the bottom is up and the front panel area is near your chest. Near the front panel area you will find a large board, this is the control unit.
4. Remove the chip resistors "Y" noted in the diagram below, and reinstall them in position "Z" as shown.
5. Reinstall the bottom cover of the transceiver and reattach the front panel.
6. Reset the microprocessor. Press and hold the MR key while the power is switched on. Then release the MR key. This will erase all operator programmed data.
7. The frequency range after modification will be:

28 Mhz Band: RX: 18.0 thru 54.0 Mhz
TX: 26.0 thru 45.0 Mhz
50 Mhz Band: RX: 40.0 thru 90.0 Mhz
TX: 46.0 thru 76.0 Mhz
144 Mhz Band: TX: 136.0 thru 174.0 Mhz
220 Mhz Band: RX: 215.0 thru 260.0 Mhz
TX: 215.0 thru 235.0 Mhz
440 Mhz Band: TX: 410.0 thru 470.0 Mhz
1.2 Ghz Band RX/TX: 1100.0 thru 1400.0 Mhz

Please note that these are theoretical ranges only. Not all radios will be capable of tuning the entire range.

Control Unit X53-346X-XX A/2

```

I
I Remove Y resistors and
---- ---- I reinstall in position Z
      Z IIYY I
---- ---- I
0000 0000 I
---- ---- I
IIYY  ZZ I
---- ---- I
2 I
R I
7 I

```

This modification is read 492 times.

[top of page](#)

23-04-2000

(TM-942) TM-742/942 28 MHz/50 MHz RC TX failure

Author: Kenwood Communication, inc.

Service Bulletin no. 1029 (29 June 1993)

Symptom:

During RC operation (remove Control) the 28 MHz and 50 MHz modules do not transmit after a frequency within the affected band is entered from the microphone keypad. Pressing the PTT key will cause a beep to be sounded but the radio will not transmit. This error is a result of a programming error in two of the microprocessors.

Corrective action:

Replace IC1 on the Control unit X53-3460 B/2 and IC1 on the Display unit X54-3130 A/3 to correct this symptom:

Parts required:

Qty	Description	Kenwood Part No.	Circuit description
1	Control unit microprocessor	HD6433388A07F	IC1
1	Display unit microprocessor	HD404719A32H	IC1

Note:

To activate the RC function after changing these two parts you need only press the RC key on the front panel of the radio. This method differs from the original method which required use of the "F" key and the "RC" key.

Caution: This modification requires soldering equipment rated for CMOS type circuits. It also requires familiarity with surface mount soldering techniques. If you do not have the proper equipment or knowledge do not attempt this modification yourself. Seek qualified assistance.

Time required for this modification is 1.5 hour or less.

This modification is read 470 times.

[top of page](#)

23-04-2000

(TM-942) TM-742/942A Microprocessor change

Author: Kenwood Communication, inc.

Service Bulletin no. 1033 (29 November 1993)

Symptom:

Reports of problems with microprocessor lock-up when using S-meter squelch, problems with storage/recall of PL tone frequencies of 203.5 Hz. and/or 114.8 Hz., or problems with a lack of transmit on the UHF band modules during Remote operation can be corrected using the changes noted in this bulletin. Units that exhibit any of these symptoms with serial numbers between 412xxxx and 507xxxx need only change IC 1 on X53-3460-21 B/2. Units that exhibit any of these symptoms with serial numbers of 412xxxx and below must also change IC1 on X54-3130-11. Units with serial numbers of 507xxxx and greater have had these changes incorporated in production.

Parts required:

Qty	Description	Old part No.	New Part No	Circuit desc.
1	Microprocessor	HD6433388A07F		
		or		
		HD6433388A14F	HD6433388A22F	IC1
1	Microprocessor	HD404719A26H	HD404719A32H	IC1

Caution: *This modification requires advanced surface mount soldering equipment that is rated for CMOS circuits. It also requires familiarity with advanced surface mount soldering techniques. If you do not have the proper equipment or knowledge do not attempt this modification yourself. Attempting to remove and replace either IC without the proper equipment and techniques can easily damage the circuit boards and void your warranty. Seek qualified assistance from your closest Kenwood Service Center (Long Beach, CA, or Virginia Beach, VA).*

Time required for this modification is 90 minutes or less.

This modification is read 463 times.

[top of page](#)

23-04-2000

(TM-942) TM-642/742/942A Microprocessor change

Author: Kenwood Communication, inc.

Service Bulletin no. 1040 (10 February 1994)

Symptom:

Due to a recent rule change by the FCC it is no longer possible to supply transceivers, or provide replacement microprocessor that would allow a transceiver to receive in the 800 MHz band.

Corrective action:

The microprocessor program of IC5 has been modified to prevent 800 MHz band reception. Production has been changed beginning with serial number lot 510xxxx. Units produced after this point will not be capable of 800 MHz reception.

Parts required:

Qty	Description	Old part No.	New Part No
1	Microprocessor	HD6433388A22F	HD6433388A25F

Procedure:

When ordering a replacement microprocessor you will be supplied with the new version. Please make sure your customer understands the limitations of this new

This modification is read 472 times.

[top of page](#)

05-01-2000

(TM-D700) KENWOOD TM-D700A Extended TX MOD (easy 3 steps)

Just received my new rig, neither the supplier nor Kenwood had the mods available to date.

1. Remove the bottom cover, 5 screws (not the speaker side).
2. Locate and remove "W601" (chip resistor) and "W602" (green wire). They are located within 2 inches of the optional VS-3 voice synthesizer board.
3. Reassemble radio and after power-up, press the reset switch on the front of radio.

Here is your new TRANSMIT range

136.000 - 174.995
400.000 - 469.995

This is the RECEIVE range (mode selected).

118.000 - 135.995
136.000 - 199.995
200.000 - 299.995
300.000 - 399.995
400.000 - 523.995
800.000 - 823.990
849.000 - 869.990
894.000 - 913.990
934.000 - 1299.990

If anyone finds other mods please drop me a line. kd4cwb@aol.com. MODIFICATION.NET

This modification is read 4692 times.

[top of page](#)

20-01-2000

(TM-D700) TM-D700 CAP/MARS

Thanks to KD4CWB for the basis for this modification

To modify the transmitter to cover 142 - 151.995 Mhz and 420-449.995 Mhz, perform the following steps:

1. **MOST IMPORTANT** - this mod will do a reset on your radio and erase ALL of your settings (memory, APRS, menus, etc.). Use the computer program to pull all of the settings out BEFORE you go any further. Or if no computer, a very large tablet. This radio has many many programable features.
2. Turn off the radio and disconnect the power
3. Remove the five screws from bottom cover (not the side with the speaker).
4. Remove the bottom cover. It may take a little prying with a small screwdriver.
REMEMBER if you haven't saved your settings, all will be lost if you proceed beyond this point.
5. Cut ONLY the famous Kenwood green wire, located near the voice synthesizer board connector. The green wire ties two PC board lands together and is about 1/2" long. Make sure the ends can't short against anything.
6. Reinstall the bottom cover.
7. Reapply power and turn the radio on (it will automatically reset).
8. Use the computer program to reinstall all of your operating parameters. I found that the load ALL function did not seem to do everything. Try the load MEMORY and MENU selections too. Or prepare to spend a whole bunch of time re-entering all of your parameters that you wrote down in step 1.

This modification is read 3542 times.

[top of page](#)

08-04-2000

(TM-D700) Kenwood TM-D700A service mode

Author: Steven Seeger - sseeger@stellartec.com.MODIFICATION.NET

The TM-D700 A/E has a service mode that lets you adjust many parameters of the radio for both bands. The setup is easy, and the following things can be adjusted:

Squelch open sensitivity

S meter calibration

Transmission output power (adjust at lower limit frequency, center frequency, upper frequency of both bands)

Transmission deviation

DCS modulation balance

Tone deviation

DCS deviation

To get into the mode, short pins 3 and 6 of the 6 pin data radio terminal.

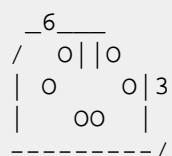

Sorry for the bad drawing, but consider each O a pin on the jack. The center slot for the plastic tab in the connector is on top of this. Pin 6 is on the upper left, pin 3 is on the right middle. With the radio powered off, short these two pins together.

Now, hold down the F and the TONE key and turn the power ON. The radio will come up with 144.000 and some data on the right side. The menus will look like they do when you're in the MNU. Use the left and right buttons to change things.

Using the <- and -> selections on the menu, you can scroll through the options. According to this spec sheet here, the radio can be set to 60W on 2 meters and 42W on 440. ALL ADJUSTMENTS ARE MADE FOR EACH BAND SEPARATELY.

Be sure to do power adjustment into a 50 ohm dummy load!

Do not worry if you don't recognize these menu names. Many of them are graphical on the bottom that change with the mode you're in.

VFO, MR, ENCODER (the left wheel), MHZ, and BAND SEL (the buttons you push to change bands) all function in this mode.

To adjust squelch sensitivity, put the desired signal on the antenna connector and press SET. (menu item on the bottom.)

To adjust the S meter, put a signal you want for S1 on the connector and press the S1 button on the bottom. Same goes for S7.

Output power is adjusted by selecting **FREQ1,2**, or **3** which sets different frequencies. Key down the mic and transmit into the dummy load. Turn the encoder left or right to adjust output power. Press **LOW** to adjust for low, medium, and high power. (make high power 5W and low power 50W, impress your friends!)

Transmission deviation is adjusted with the <- and -> buttons. There's a **MAX DEV** setting if you want to bleed over to adjacent frequencies. (piss off your friends!) Press the **SET** key to set it.

DCS modulation balance is set with <- and -> and by pressing the **SET** key.

Same goes for **TONE** deviation and **DCS** deviation.

Enjoy!

-Steve KF6WJH

04-06-2000

(TM-D700) TM-D700A/E Cross band repeat

Author: Kenwood Communication, inc.

Modification procedures for models to other Type (Transmitter band expansion, ext)

Set a desired destination by adding or deleting three chip jumpers (R659, R661, R662) and a lead jumper (W602) on the foil side of the TX-RX unit (X57-586X-XX). (Refer to the attached tables 2 to 19 for details.) [Didn't get a copy of those].

1. Remove R659 and W062 to extend the transmitting band.
2. Remove R675 to modify the channel display mode. [Shows channel instead of frequency?]
3. Remove R674 to modify the repeater.

(Repeater in TM-D700A to U.S.A./Canada has already been modified before factory)

Another note not from Kenwood.

I have looked at the board and cannot find R674, however there are two chip resistors (0 ohm?) labelled REPTER and CH. As a guess these are R674 and R675 respectively. I may try to remove REPTER later and watch the results.

Usual caveats in place, if it breaks because of these mods, you are on your own.

This modification is read 3445 times.

[top of page](#)

06-08-2000

(TM-D700) Repeater functions. U.S.A. / Canada only

Author: Marcel Chabot - mchabot@kabelfoon.nl. MODIFICATION.NET

This transceiver is capable of receiving signals on one band and retransmitting signals on the other band. This function repeats signals originating from one band, using the other band. For example, a signal received on band A (VHF) is retransmitted on band B (UHF). Similarly, a signal received on band B (UHF) is retransmitted on band A (VHF).

Access Menu 1-7-6 (REPEATER) and select "Locked" band Repeater or Cross-band Repeater. The default is "OFF".



Locked-band Repeater

The transceiver always uses the same band to receive or transmit a signal as a repeater. Before accessing Menu 1-7-6, select one band as the TX band and the other band as the control band.

Cross-band Repeater

If receiving a signal on the TX band, the transceiver switches the current RX only band to the TX band. Before accessing Menu 1-7-6, select the same band as the TX and control bands.

82

If necessary, you can cause this transceiver to remain in the transmit mode for 500 ms after signals drop. Access Menu 1-7-5 (REPEATER HOLD) and select "ON".



Note:

- You cannot activate the Repeater function after recalling the same frequency band (VHF or UHF) on band A and B, or while blanking a band display.
- Activating the Repeater function switches OFF Automatic Band Change (A.B.C.) or automatic Simplex Check (ASC).

- The Time-Out Timer is locked at 3 minutes.
- After activating the Repeater function, you cannot access Menu Nos. other than 1-7-5 and 1-7-6.

This modification is read 3034 times.

[top of page](#)

06-08-2000

(TM-D700) Enable Crossband Repeater Function TM-D700E Version

Author: Robert PD0PVL - pd0pvl@amsat.org.MODIFICATION.NET

To enable crossband repeater function in the TM-D700E Remove 0 ohm resistor above the word repter written on the pcb. it works fine here.

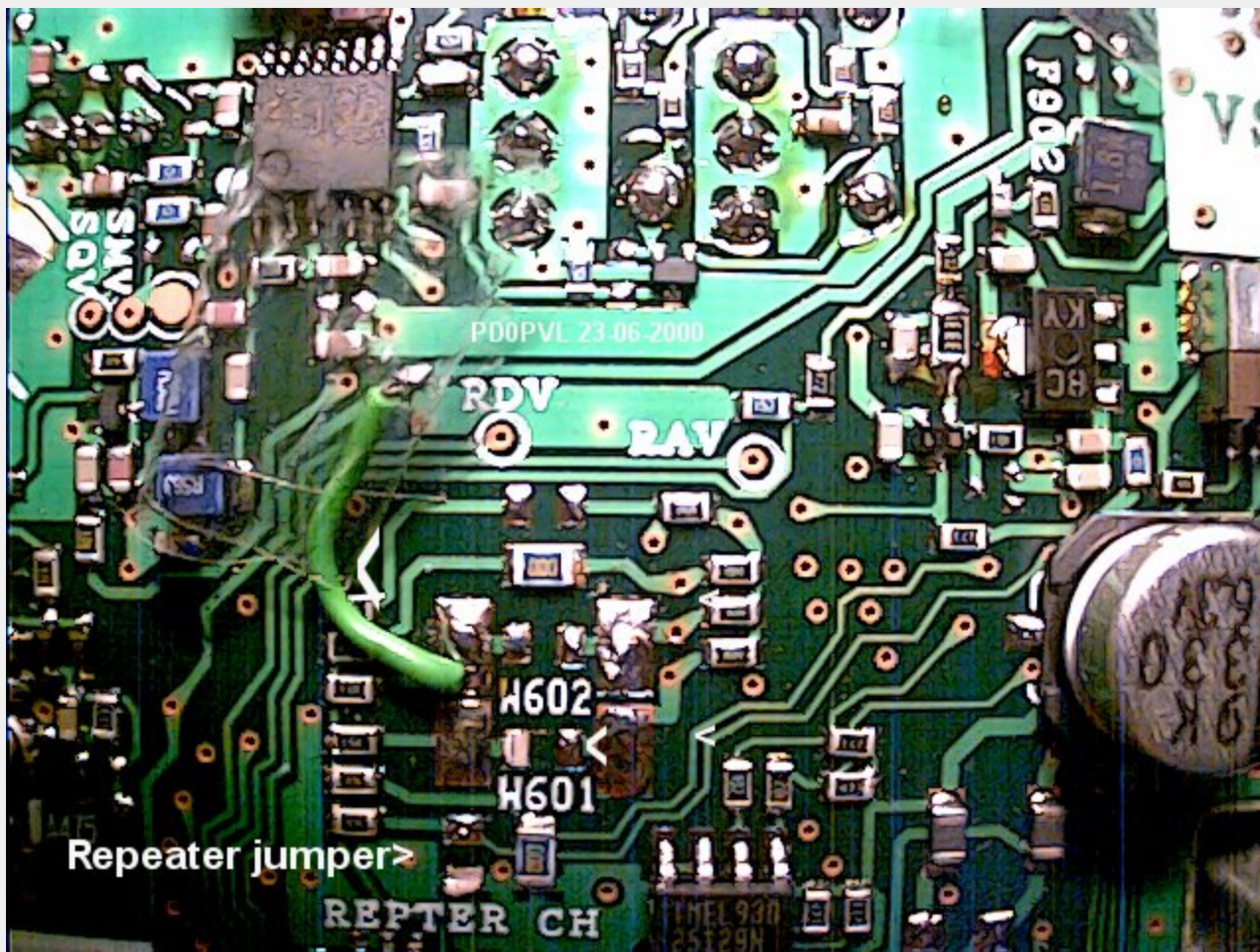

This modification is read 3108 times.

[top of page](#)

24-09-2000

(TM-D700) Update for the Kenwood TM-D700A/E Deviation level

Author: Kiely Petersen ZL1WPK - zl1wpk@ihug.co.nz.MODIFICATION.NET

To adjust the Transmission deviation level you need to get into the service mode.

Then scroll through the options to the deviation section.

Then press and hold the Mic (PTT) in then turn the tuning control to select the deviation you want. Then Press the SET key to set it.

Both VHF/UHF need to be adjust separately.

Kiely Petersen ZL1WPK

This modification is read 3143 times.

[top of page](#)

05-11-2000

(TM-D700) Demonstration mode for TM-D700

Author: Kiely Petersen - ZL1WPK - zl1wpk@ihug.co.nz.[MODIFICATION.NET](http://www.MODIFICATION.NET)

To see a demonstration mode press and hold the (F) Key and Turn the radio on

Stop the demonstration Turn radio off then press (F) Key and Turn the radio on

This modification is read 3085 times.

[top of page](#)

21-11-2000

(TM-D700) TM-D700A MC53-DM MIC PTT Spring tension MOD

Author: Scott, KF4NDQ

This reduces the pressure required to key the mic to about half or less. (Sorry I do not have any measuring instruments). Perform at your own risk.

1. Turn off radio. Leave Mic connected to radio and radio connected to power. This will reduce the chances of static discharge blowing the IC behind the cover. Ground yourself.
2. Remove the 3 screws from the back of the mic and gently remove cover. Inside the large PTT housing you will notice a spring with BLACK foam in it as well as a piece of RED foam that comes in contact with the actual PTT micro switch.
3. From the bottom of the PTT pull upwards until the PTT housing comes out of the MIC housing. Take care not to damage the RED foam.
4. Pull the spring with the BLACK foam out of the PTT housing. Store in a safe place as you may not like the difference it makes.
5. Carefully reinsert the PTT housing, again taking care not to damage the RED foam.
6. Replace the rear cover. DO NOT OVERTIGHTEN SCREWS. Test PTT. Test APRS messaging from Keypad. This will verify the IC has not been damaged.

Hope it works for you!

Scott
KF4NDQ

This modification is read 2884 times.

[top of page](#)

26-03-2002

(TM-D700) TM-D700E Sky command/Remote enable

Author: David Bray - davidbray@xtra.co.nz.[MODIFICATION.NET](http://www.MODIFICATION.NET)

1. Cross band repeater : Remove R674.
(I cant guess the reason of muffled and poor sound)
2. Sky Command : A chip jumper (0ohm) must be soldered onto the place for "R662".

To activate sky command function, it is not necessary to change the firmware.
But this modification may expands TX/RX frequency range.

Note: This basically changes the model from TM-D700E to TM-D700A(USA Model).Back-up your data with a PC as the mod will reset your radio. When you re-load the data, change the model to TM-D700A.

[Download picture.](#)

This modification is read 63 times.

[top of page](#)

19-07-1998

(TM-G707) Extended RX and TX for Kenwood TM-G707

1. Remove the dettacheble front from the tranceiver.
2. Remove the bottom case. (4 screws in each corner).
3. Put the tranceiver in front of you, upside down, with the antenna connecter pointed at you.
4. Locate in the upper right corner on the small vertical placed print (witch is located behind the display adaptor) a group of 4 small 0 Ohm resistors in smd format, numbered 0-1-2-3.
5. Remove or lift resistor 0 for extended RX

RX band 1 = 118-136 Mhz AM
RX band 2 = 136-174 Mhz FM
RX band 3 = 300-400 Mhz FM
RX band 4 = 400-520 Mhz FM
RX band 5 = 800-999 Mhz FM

6. Remove or lift resistor 3 for extended TX

TX band 2 = 136-174 Mhz FM
TX band 4 = 400-520 Mhz FM

Note:

When these two resistors are removed or lifted, in the MENU there will be een extra menu-choise (number 0) to switch between AM and FM on all 5 bands (AM only receive).

Date: 16-04-2001

User comment

From: unknown

Subject: Correct mod!

The mod listed for super-expanded frequency coverage (RX and TX) of the Kenwood TM-G707 is incorrect!

I have read multiple reports (also on QRZ) that for the expanded frequency coverage, it is necessary to remove the SMT resistor marked "1", NOT the one marked "0".

This is INCORRECT, at least in my radio, which was purchased NEW on 4-3-01. Removal of resistor "1" changed my radio from the "American" version to the "European" version (described in more detail in the instruction manual), which actually DECREASED the frequency coverage to LESS than it was before modification (again, both RX and TX were severely limited)!

Also, the ability to program the microphone buttons yourself was totally disabled. I called Kenwood and they couldn't help me, since the mod I'd performed was not endorsed by Kenwood.

I put resistor "1" back in place, and removed resistor "0". All the disabled functions were restored, and the frequency modification (both RX and TX) was completed. This correction may not be the case with all of the TM-G707's out there, so my advice is to remove only one side of the resistor you choose to try. Using your soldering iron, heat it up and just bend it up far enough to break the connection, without removing it completely from the PCB.

If you notice undesireable changes in your radio, reconnect it and try the other one. There are only 2 of these resistors in my radio, so it should be a simple process of elimination. Good Luck!

Date: 28-01-2002

User comment

From: [Lion Templin KB9ENE](#)

Subject: Another variant to the TM-G707 resistor removal mod

The "resistor removal" mods listed here are almost right for my TM-G707, which has a serial number series 301xxxxx. Only two of the SMT resistors were present, 0 and 1. Removing 0 opened up the extended RX capability, however, it resulted in leaving the radio in limited TX on 440 (probably the European band limits). Removing resistor 1 opened up extended TX, and removed the limitation previously imposed on 440.

At the end of the mod I had NO resistors on any of the 4 available pads.

Date: 30-01-2002

User comment

From: [Nathan](#)

Subject: Incorrect Information

The person that has typed up this modification has made a nice mistake which cost me quite abit of money.

The radio no amtter what country version it is USA or European will not do about 470mhz Transmit but will on the recieve.

The US version comes with only resisters 0 and 1 if you remove both your get extended RX & TX.

In regards to the Euro version you remove the resisters as per the instructions in the above mod.

Date: 15-02-2002

User comment

From: [Chris VE3NGW/W4 FLORIDA](#)

Subject: WARNING! DO NOT REMOVE THE DIODES

Subject: WARNING! From CK Radio Florida

Please DO NOT remove the diodes on this radio.

Certain versions of this radio are different and by removing the diodes you will cause the radio to become innoperative.

All you need to cover Tx-Rx Expansion is to

Turn the radio upside down.

Take off the bottom cover 4 screws.

Remove the cover.

Look towards the front of the radio and locate the vertical display board.

Look for two thin green wires behind the two diodes mentioned

in the previous articles.

CUT the green wire furthest away from the side of the radio

that the mic connector is on.

THAT'S ALL YOU NEED TO DO.

This mod works on the TM-733 and the TM-G707.

Good Luck, 73 Chris

This modification is read 2846 times.

[top of page](#)

12-01-2001

(TM-G707) Extended RX MOD for Kenwood TM-G707A

Author: Kenwood

This from the Kenwood Factory Website...

1. Disconnect power cord and antenna from transceiver
2. Detach the head
3. Remove Top and Bottom screws (9 total)
4. Lift the locking tabs on top and bottom side of the front panel, pull the front panel forward to expose the control board. DO NOT BREAK THE TWO RIBBON CABLES!!!! They connect the control board to the TX-RX board.
5. Remove the single screw from the control board to access the bottom of the board (component side). There is NO need to disconnect the ribbon cables!!
6. Locate the TWO GREEN JUMPER WIRES on the component side of the control board.
7. Cut the one labeled W501 (SEE ILLUSTRATION) AND IF NEED BE INSULATE THE END TO PREVENT CONTACT.
8. Re-assemble and power up unit. It will automatically reset.

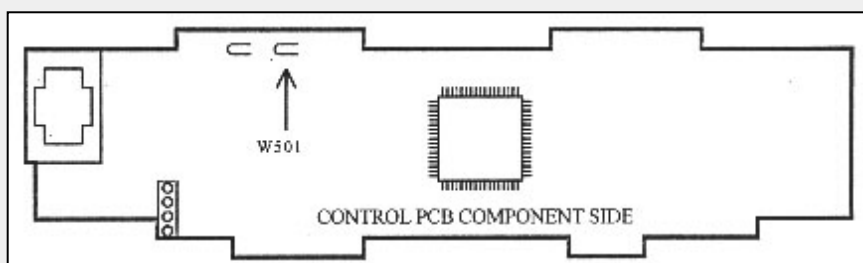

New receive capability-

118.00-173.995

320.00-399.995

400.00-523.995

800.00-823.9875

849.00-865.9875

894.00-949.9875

Date: 15-02-2002

User comment

From: [Chris VE3NGW/W4 FLORIDA](#)

Subject: WARNING! From CK Radio Florida

Please DO NOT remove the diodes on this radio.
Certain versions of this radio are different and by removing the diodes you will cause the radio to become innoperative.
All you need to cover Tx-Rx Expansion is to
Turn the radio upside down.
Take off the bottom cover 4 screws.
Remove the cover.
Look towards the front of the radio and locate the vertical display board.
Look for two thin green wires behind the two diodes mentioned
in the previous articles.
CUT the green wire furthest away from the side of the radio
that the mic connector is on.
THAT'S ALL YOU NEED TO DO.
This mod works on the TM-733 and the TM-G707.
Good Luck, 73 Chris

Date: 20-02-2002

User comment

From: [Gary AB7NI](#)

Subject: Update mod

On mine the first green wire cut opened up the RX, but I also needed to cut the second green wire for expanded transmit of 142-151Mhz. It would not TX beyond those points. Anyone else have a differencnt result?

This modification is read 2266 times.

[top of page](#)

08-03-2002

(TM-G707) Low Audio Fix for Kenwood TM-G707

Author: Jim WDOJIM - wd0jim@arrl.net. MODIFICATION.NET

I have two of these rigs and both had low audio. I searched the Internet for a solution and could not find one so I spent \$23.00 and purchased the service manual. So for everyone that has low audio here is my gift to you!

****Perform at your own risk****

1. Place the radio into Service Adjustment Mode by shorting pins 3 (PKS) and 6 (SQC) on the data jack on the front left side of the radio under the protective cap.
2. Power up the radio while holding "F" key and "TONE" key
3. Put radio into VFO mode and select a 2 meter frequency and monitor it with another rig. (I used headphones to prevent feedback)
4. Press MNU to activate adjustment mode
5. Press the keys to get to the DEVI menu
6. Key mic and speak and listen through other radio.
7. Turn the encoder knob until you hear the audio level you want. Mine sounded good when the value was "BB"
8. Press "OK" button to save new deviation value.
9. Press MNU to return to VFO mode.
10. Select a 440 frequency and repeat steps 3-9 for the 440 band. Deviation is set independently for each band.
11. When complete, power off radio and remove shorting plug. Your radio no longer has low audio!

**** Tip for shorting plug****

I purchased a PS/2 keyboard extension cable as the connector is the same and inserted a wire between pins 3 + 6 to put into adjustment mode.

Pin 3 is at the 3 o'clock position and pin 6 is at the 10 o'clock position when looking at the front of the rig and the connector is on your left hand.

Good luck and 73.

28-03-1999**(TM-V7A) Expanding the Kenwood TM-V7: A & E versions***Original TM-V7A Mod from NFXQ96A@prodigy.com.MODIFICATION.NET (MR CORY B MCDONALD)**Additional TM-V7E notes from bowyermj@state.gov.MODIFICATION.NET (Mike Bowyer)*Original TM-V7A Mod:

Remove the top and bottom covers.

Look at the vertical p.c. board behind the front of the radio. There will be 2 small chip resistors on the left side of the board.

Carefully remove the one with the number 0. It will be the one closest to the left near the grounding spring. You will probably have to scrape it off with a pair of needle nose pliers.

After you remove it the VFO ranges should be:

VHF TX 136.995 - 173.995. RX should be 118-174.

UHF TX should be 410-469.995 RX should be 300-470.

Additional TM-V7E notes:

There is a row of five numbered links on the edge of the front panel board.

In my E version radio, 0, 2 & 3 were made as standard. I now have only one link fitted in the number 4 position which enables the repeater function not defaulted in European versions. I have removed all other links.

I can now also receive the AM Aircraft band (118-137MHz). It is possible to change from AM to FM by pressing the MHz button for 1 second. Plus I have discovered doing the same key press (MHz for 1s) in the UHF band gives a 800-999Mhz RX band.

The European version has a 1750Hz tone-burst function, a modified band plan for the auto-repeater shift function, adds a -7.6Mhz repeater shift and sets the band limits to 144-146 & 430-440 - the AM Air band & 800Mhz bands are disabled. All these European 'features' are lost when the radio is expanded.

(The repeater offsets are still programmable, but you must learn how to whistle at 1750Hz). I think the only other difference between the A and E versions is that the E version has an N type antenna connector fitted.

Making link number 5 causes the radio to power up in a Memory recall mode (i.e., with channel numbers) and so is not overly useful!

I'm not sure exactly what links 0, 1, 2, & 3 all do individually! Maybe other configurations are possible: any information would be gratefully received.

As for RF performance, the front-end (and PA) must be tweaked to use frequencies other than the factory aligned defaults, with a little tweaking out of band performance should come good (at the expense of regular 2m/70cm performance).

The chip resistors are SMD zero ohm things - a wire link (or solder blob) will do the same job. They can be carefully removed (for re-use) by using a fine tipped iron, de-solder braid, and a pair of long nose pliers or tweezers. The front board can be carefully detached from the rest of the radio to make removing the links easier.

Mike Bowyer.

Date: 13-10-2001**User comment****From:** [Bg36c](#)**Subject:** DTSS

The DTSS will be disabled and no longer function after performing this mod. At least it doesn't on my radio anymore.

02-12-1999**(TM-V7A) PG-4S programmer cable for the TM-V7x**

Author: Wulf, DB8KY

NOTE: This is not a copy of the existing PG-4S cable but a replacement designed by DB8KY.

One of the most handy things about this transceiver is: you can program this transceiver by computer. You can download the software from the Kenwood site but there no datasheet of the PG-4S cable which you require. I found a datasheet which replace the PG-4S cable and is designed by DB8KY. I made this cable and it works fine on my transceiver.

The manual is written in German by DB8KY. He said he never tried this cable on a TM-V7, but it works very good on my transceiver. So here below you will see the instructions.

Have fun! PE1PTS

Der Kenwood TM-G707E ist ja ein schoenes Geraet und die Vergabe von Speichernamen ein nettes Feature, wenn man das alles nur vom Rechner aus programmieren koennte...

Kann man, die Software dazu steht bei Kenwood auf der Web-Seite, dann fehlt nur das Kabel zum Anschluss an den Rechner. Ich habe zwar keine Ahnung was sich in dem original PG-4S Kabel von Kenwood abspielt, wenn man den TM-G707E aber in den Clone-Mode versetzt und sich mal die Signale auf der Mini-DIN Buchse ansieht wird klar, dass es sich bei der Elektronik im Kabel um einen TTL/RS232-Wandler handeln muss. Die unten dargestellte Schaltung erfuellt diese Aufgabe bei mir jedenfalls klaglos. Ich denke das ganze funktioniert auch am TM-V7E.

Wie funktioniert es:

Die Verbindung zwischen Pin 4 und 5 benoetigt der Kenwood wohl um von FSK auf seriellen Betrieb umzuschalten. Das Signal vom PC zieht ueber R5 mit T2 den RxD-Eingang am Kenwood low, hier ist intern offensichtlich bereits ein Pull-up

Widerstand vorhanden. Schwieriger ist der Weg vom Kenwood zum PC, der Kenwood gibt nur ein TTL-Signal aus, der serielle Eingang am PC will aber +/- ca. 10V sehen. Also muessen zwei Hilfsspannungen gewonnen werden. Aus dem RTS-Signal des PC wird ueber R1 eine positive Spannung gewonnen und mit D1 und C1 stabilisiert. Aus dem TxD-Signal des PC wird ueber D3 und R6 dann noch eine negative Spannung gewonnen und mit C2 gepuffert. Dann kann der Kenwood mit den Sendedaten ueber T1 jetzt zwischen der positiven und negativen Spannung umschalten.

Ich habe das ganze in den Sub-D Stecker reingefummelt.

Viel Spass damit wuenscht Wulf, DB8KY

DB8KY @DB0RWI.#NRW.DEU.EU

(Wer das nachbaut tut es auf seine eigene Verantwortung)

PC D-Sub 9pin TM-G707E 6pol. Mini-DIN

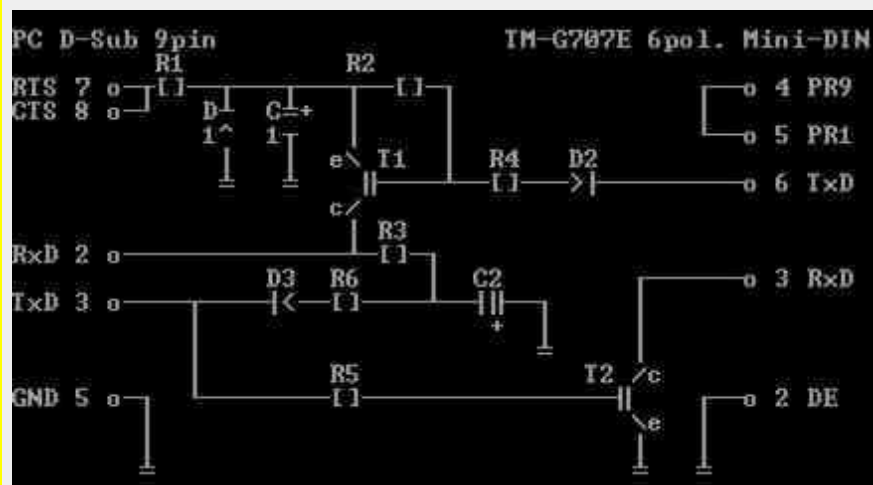

R1/R6 = 150 Ohm

R2 22 kOhm

R3 10 kOhm

R4 33 kOhm

R5 15 kOhm

C1/C2 = 1uF/16V Elko

D1 = Z-Diode 5,1 Volt

D2/D3 = 1N4148 oder aehnlich

T1 = BC558A oder aehnlich

T2 = BC337 oder aehnlich

For an English Interpretation, visit [KC7ZRU's pages](#). Includes RS part numbers, re-drawn schematic and user comments.

This modification is read 2163 times.

[top of page](#)

Author: Kenwood

AAN-0020 (12-12-1996)

External remote control of the TM-V7A transceiver using DTMF tones that are transmitted by another transceiver is possible using the following procedure:

1. Ensure the UHF control frequency of the TM-V7A and the remote transceiver are the same.
2. Turn on the DTSS function for the TM-V7A UHF-band and select DTSS tone sequence.
3. Turn the DTSS function for the UHF band on the TM-V7A OFF.
4. Press the "Band selector" button for the VHF band on the TM-V7A.
5. Turn OFF the TM-V7A, press and hold the CONT SEL. Key, turn ON the TM-V7A and the release the CONT SEL. Key.
6. This will place the transceiver in the EXT standby mode. The words "EXT REMOTE" are displayed, the "DT" indication for the UHF band will begin flashing, the LOCK indication will turn ON and all front panel keys on the TM-V7A will be disabled except the "PWR" key, and the microphone keys.
7. To begin remote control you should key the transceiver and press the following key sequence:
[A] [*] [*][*][#], where "****" is the preset DTSS code selected in step 2.
8. If the proper code is received by the TM-V7A the beeper will sound, and the "DT" indicator will stop flashing. This indicates the transceiver can now be remotely controlled from the external transceiver. See the Ext. Remote Function" chart below of the bulletin for those functions that can be controlled.
9. When you have finished and wish to return to the EXT standby mode, you should press:
[A][*]
10. The "DT" indicator on the TM-V7A will begin flashing to confirm the radio again in the standby mode.
11. To return to normal operation, turn the transceiver OFF, press and hold the CONT SEL. Key, and then turn the radio back on.
Repeat one more time.

Ext. Remote Function Chart

REV ON 1	TOPE ON 2	CTCSS ON 3	ENT A
REV OFF 4	TOPE OFF 5	CTCSS OFF 6	TOPE SEL B
CALL 7	VFO 8	MR 9	REPEATER ON C
DWN *	LOW U	UP #	REPEATER OFF D

1. Conversion function items and conversion types

1. Reception wide band [Conversion A] K destinations outside 800-MHz band support
2. Cross band repeater ... [Conversions A and B] Complete with K destination measures
3. Page answer back ... [Conversions A and B] ... Complete with K destination measures
4. DTMF remote [*]

* Operates even without conversion, but some items function when Conversions A and B are made.

2. Conversion Methode

1. Conversion location

Remove the power cord from the main unit, remove the upper/lower case, flip down the panel as in the figure below, than operate.

Factory setting destination jumper table.

Destination jumper		Destination		
Bit	Ref. no. (K destination)	K	M	E
3	R542 (W501)	O	X	O
2	R543 (W502)	O	X	O
1	R544	O	O	X
0	R546	O	X	O

O: = Jumper

X: = No jumper

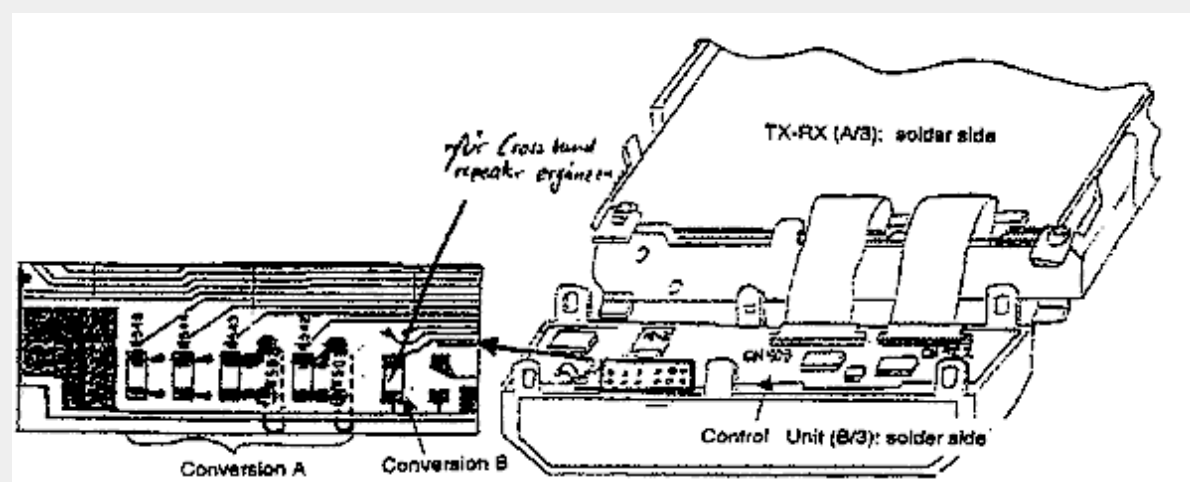

Conversion A Reception wide band (Already dealt with for M destinations)

E destination Eliminates mounted chip jumper resistor R542 (0 ohm).

K destination Cuts the mounted jumper wire (W501).

Conversion B Repeater/answer back (Already dealt with for K destinations)

Chip jumper resistor 0 ohm added (R92-0670-05)

* The chip removed in Conversion A can be used in Conversion B.

* When adding or eliminating the chip jumper resistor, be careful not to peel off any printed circuit pattern and not to harm any other parts.

2. Contents of settings by destination

For the list of contents of settings for each destination, see (Appendix tables 1 - 5).

Author: Jann DG8NGN - jann@gmx.de. MODIFICATION.NET

To program your memories of the Kenwood TM-V7 you need this interface. The software is downloadable at Kenwoods Webpage www.kenwood.net, or [here](#). Download the MV7101.EXE file. The software can only communicate with serial port 1 or 2!
 mods.dk/manuals/kenwood/TM-V7_MCP-V7_Version_1.01_Memory_Control_Program.zip

Parts list. R1/R6 = 150 Ohm

R2 = 22 Kohm

R3 = 10 Kohm

R4 = 33 Kohm

R5 = 15 Kohm

C1/C2 = 1uF/16V

D1 = 5,1 V Zenerdiode

D2/D3 = 1N4148 or equal

T1 = BC558A or equal

T2 = BC337 or equal

Schaltplan PG-4S Kabel für Kenwood TM-V7 und TM-G707

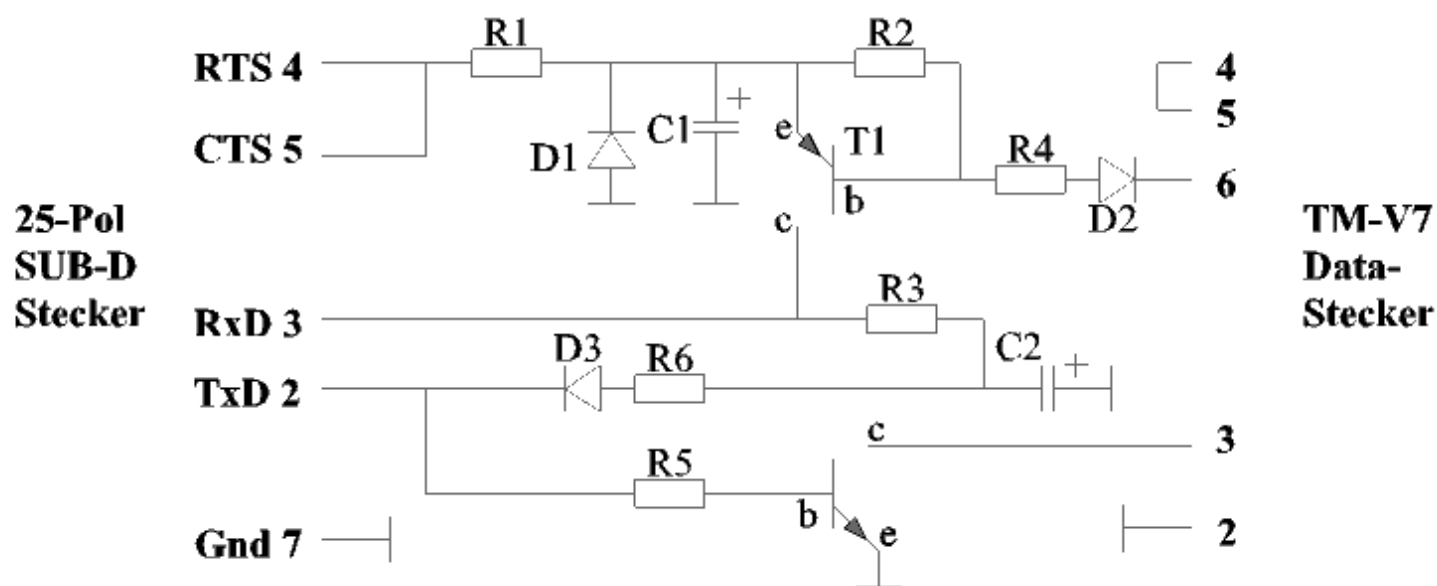

Platinenlayout für PG-4S-Adapter im SUB-D 25-Pol-Gehäuse:

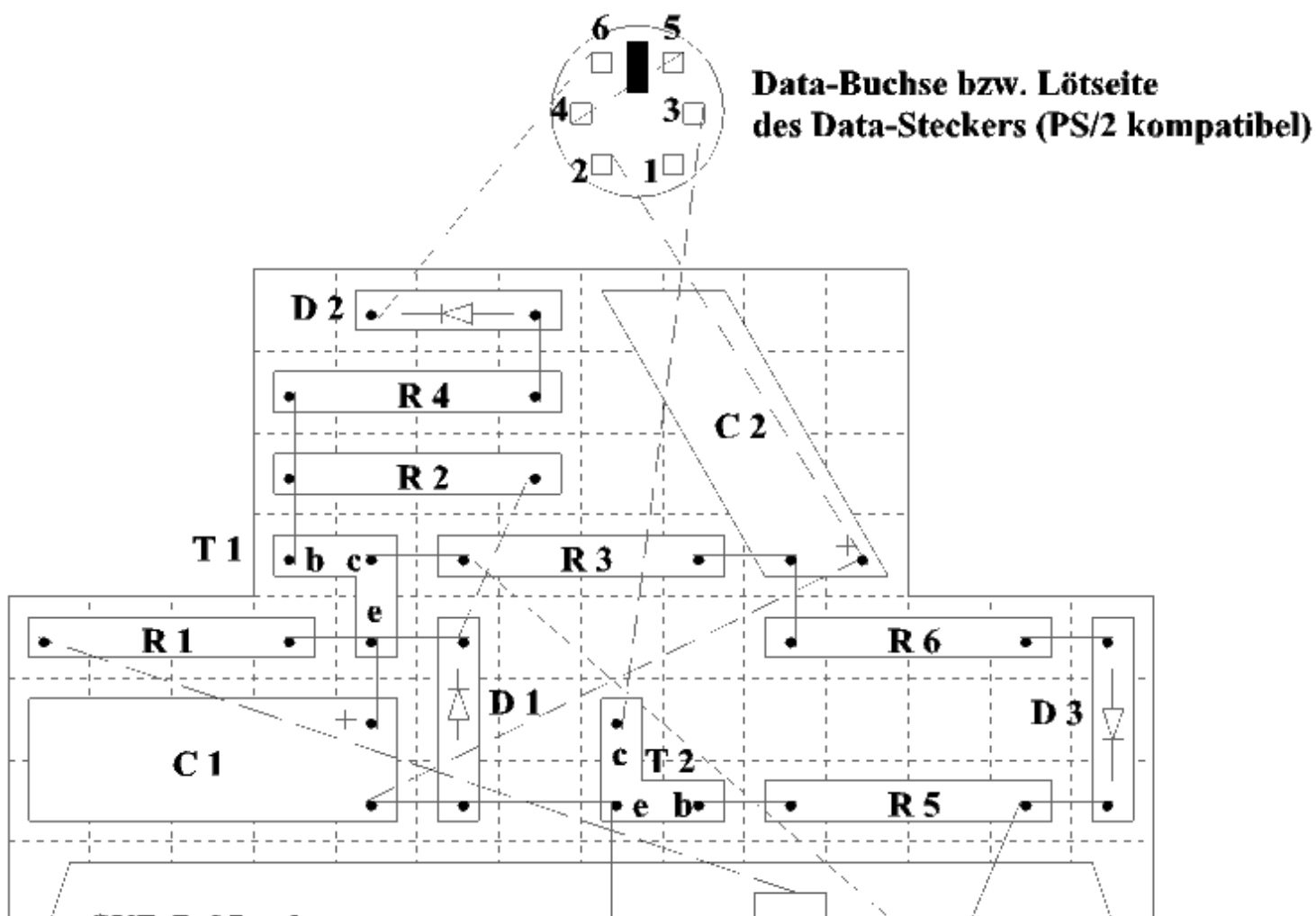

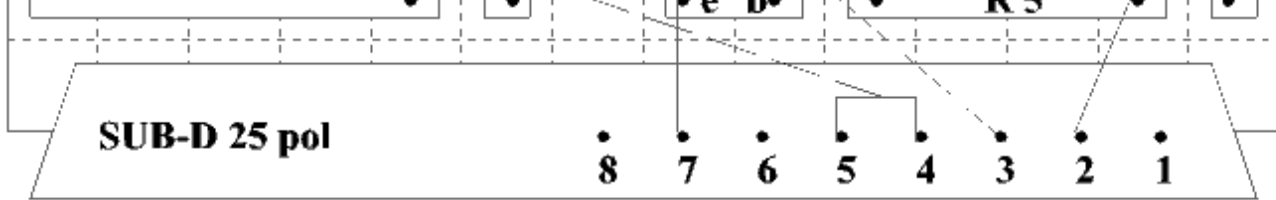

by DG8NGN Jann (jann@gmx.de) and DO1NK Karin. Special thanks to DB8KY.

Symbolerklärung:

Linien:

verlötet —————

verkabelt - - - - -

Transistoren Draufsicht (Beinchen unten):



This modification is read 1885 times.

[top of page](#)

19-07-1998

(TM-V7E) TM-V7E mike & PF1 <> PF4 (1750hz)

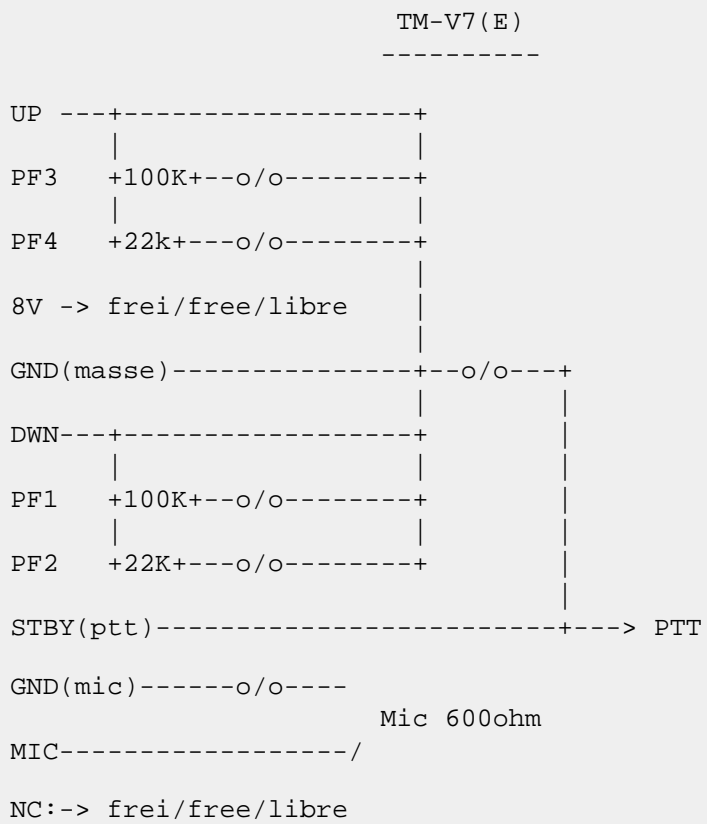

Legende:

o/o = Schalter oder Taster / switch / bouton ou interrupteur

This modification is read 1951 times.

[top of page](#)

28-03-1999

(TM-V7E) Expanding the Kenwood TM-V7: A & E versions

Original TM-V7A Mod from NFXQ96A@prodigy.com.MODIFICATION.NET (MR CORY B MCDONALD)

Additional TM-V7E notes from bowyermj@state.gov.MODIFICATION.NET (Mike Bowyer)

Original TM-V7A Mod:

Remove the top and bottom covers.

Look at the vertical p.c. board behind the front of the radio. There will be 2 small chip resistors on the left side of the board.

Carefully remove the one with the number 0. It will be the one closest to the left near the grounding spring. You will probably have to scrape it off with a pair of needle nose pliers.

After you remove it the VFO ranges should be:

VHF TX 136.995 - 173.995. RX should be 118-174.

UHF TX should be 410-469.995 RX should be 300-470.

Additional TM-V7E notes:

There is a row of five numbered links on the edge of the front panel board.

In my E version radio, 0, 2 & 3 were made as standard. I now have only one link fitted in the number 4 position which enables the repeater function not defaulted in European versions. I have removed all other links.

I can now also receive the AM Aircraft band (118-137MHz). It is possible to change from AM to FM by pressing the MHz button for 1 second. Plus I have discovered doing the same key press (MHz for 1s) in the UHF band gives a 800-999Mhz RX band.

The European version has a 1750Hz tone-burst function, a modified band plan for the auto-repeater shift function, adds a -7.6Mhz repeater shift and sets the band limits to 144-146 & 430-440 - the AM Air band & 800Mhz bands are disabled. All these European 'features' are lost when the radio is expanded.

(The repeater offsets are still programmable, but you must learn how to whistle at 1750Hz). I think the only other difference between the A and E versions is that the E version has an N type antenna connector fitted.

Making link number 5 causes the radio to power up in a Memory recall mode (i.e., with channel numbers) and so is not overly useful!

I'm not sure exactly what links 0, 1, 2, & 3 all do individually! Maybe other configurations are possible: any information would be gratefully received.

As for RF performance, the front-end (and PA) must be tweaked to use frequencies other than the factory aligned defaults, with a little tweaking out of band performance should come good (at the expense of regular 2m/70cm performance).

The chip resistors are SMD zero ohm things - a wire link (or solder blob) will do the same job. They can be carefully removed (for re-use) by using a fine tipped iron, de-solder braid, and a pair of long nose pliers or tweezers. The front board can be carefully detached from the rest of the radio to make removing the links easier.

Mike Bowyer.

Date: 13-10-2001

User comment

From: [Bg36c](#)

Subject: DTSS

The DTSS will be disabled and no longer function after performing this mod. At least it doesn't on my radio anymore.

Date: 02-02-2002

User comment

From: [philip](#)

Subject: kenwood tmv7 extended tx

with reference to the above mod ,yes all works fine but no extended tx

i have no jumpers conected from 0 to 4 no 4 has a wire jumper,this enables extended rx, but to extend the tx you must add a wire jumper to no 2 .

regards phil

02-12-1999

(TM-V7E) PG-4S programmer cable for the TM-V7x

Author: Wulf, DB8KY

NOTE: This is not a copy of the existing PG-4S cable but a replacement designed by DB8KY.

One of the most handy things about this transceiver is: you can program this transceiver by computer. You can download the software from the Kenwood site but there no datasheet of the PG-4S cable which you require. I found a datasheet which replace the PG-4S cable and is designed by DB8KY. I made this cable and it works fine on my transceiver.

The manual is written in German by DB8KY. He said he never tried this cable on a TM-V7, but it works very good on my transceiver. So here below you will see the instructions.

Have fun! PE1PTS

Der Kenwood TM-G707E ist ja ein schoenes Geraet und die Vergabe von Speichernamen ein nettes Feature, wenn man das alles nur vom Rechner aus programmieren koennte...

Kann man, die Software dazu steht bei Kenwood auf der Web-Seite, dann fehlt nur das Kabel zum Anschluss an den Rechner. Ich habe zwar keine Ahnung was sich in dem original PG-4S Kabel von Kenwood abspielt, wenn man den TM-G707E aber in den Clone-Mode versetzt und sich mal die Signale auf der Mini-DIN Buchse ansieht wird klar, dass es sich bei der Elektronik im Kabel um einen TTL/RS232-Wandler handeln muss. Die unten dargestellte Schaltung erfuellt diese Aufgabe bei mir jedenfalls klaglos. Ich denke das ganze funktioniert auch am TM-V7E.

Wie funktioniert es:

Die Verbindung zwischen Pin 4 und 5 benoetigt der Kenwood wohl um von FSK auf seriellen Betrieb umzuschalten. Das Signal vom PC zieht ueber R5 mit T2 den RxD-Eingang am Kenwood low, hier ist intern offensichtlich bereits ein Pull-up

Widerstand vorhanden. Schwieriger ist der Weg vom Kenwood zum PC, der Kenwood gibt nur ein TTL-Signal aus, der serielle Eingang am PC will aber +/- ca. 10V sehen. Also muessen zwei Hilfsspannungen gewonnen werden. Aus dem RTS-Signal des PC wird ueber R1 eine positive Spannung gewonnen und mit D1 und C1 stabilisiert. Aus dem TxD-Signal des PC wird ueber D3 und R6 dann noch eine negative Spannung gewonnen und mit C2 gepuffert. Dann kann der Kenwood mit den Sendedaten ueber T1 jetzt zwischen der positiven und negativen Spannung umschalten.

Ich habe das ganze in den Sub-D Stecker reingefummelt.

Viel Spass damit wuenscht Wulf, DB8KY

DB8KY @DB0RWI.#NRW.DEU.EU

(Wer das nachbaut tut es auf seine eigene Verantwortung)

PC D-Sub 9pin TM-G707E 6pol. Mini-DIN

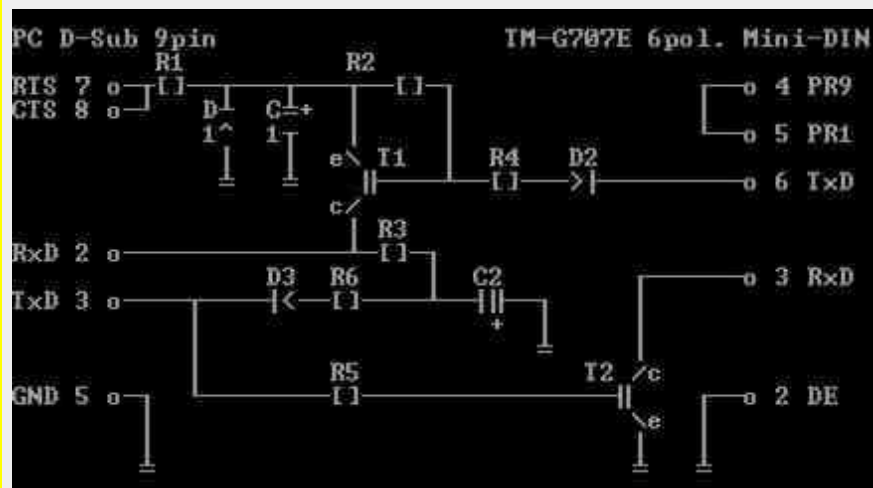

R1/R6 = 150 Ohm

R2 22 kOhm

R3 10 kOhm

R4 33 kOhm

R5 15 kOhm

C1/C2 = 1uF/16V Elko

D1 = Z-Diode 5,1 Volt

D2/D3 = 1N4148 oder aehnlich

T1 = BC558A oder aehnlich

T2 = BC337 oder aehnlich

For an English Interpretation, visit [KC7ZRU's pages](#). Includes RS part numbers, re-drawn schematic and user comments.

This modification is read 2056 times.

[top of page](#)

02-07-2000

(TM-V7E) Expanded RX/TX and crossband repeater

If you want just mod the RX QRG remove the resistor R546.

For the TX-RX mod remove R542 & R546

	TX	RX	TX	RX
3210				
OOXO	144/146	144/146	430/440	430/440
XOXO	144/146	144/146	432/438	432/438
OXXO	144/146	118/174	430/440	300/470
XOXX	136/174	118/174	410/470	300/470

REM: With one of this 4 mods you can have the 1750 of the mike.

But if you want have the biggest mod (but no 1750) you can try:

XXXX	136/174	118/174	410/470	300/524
XXXO	136/174	118/174	410/470	300/524

For the cross band repeater jump the strap 4

0 1 2 3 4 5 6

- 3= R542 (W501)
- 2= R543 (W502)
- 1= R544
- 0= R546

- O = JUMPER
- X = NO JUMPER

This modification is read 2355 times.

[top of page](#)

28-10-2001

(TM-V7E) Conversion document

1. Conversion function items and conversion types

1. Reception wide band [Conversion A] K destinations outside 800-MHz band support
2. Cross band repeater ... [Conversions A and B] Complete with K destination measures
3. Page answer back ... [Conversions A and B] ... Complete with K destination measures
4. DTMF remote [*]

* Operates even without conversion, but some items function when Conversions A and B are made.

2. Conversion Methode

1. Conversion location

Remove the power cord from the main unit, remove the upper/lower case, flip down the panel as in the figure below, than operate.

Factory setting destination jumper table.

Destination jumper		Destination		
Bit	Ref. no. (K destination)	K	M	E
3	R542 (W501)	O	X	O
2	R543 (W502)	O	X	O
1	R544	O	O	X
0	R546	O	X	O

- O: = Jumper
- X: = No jumper

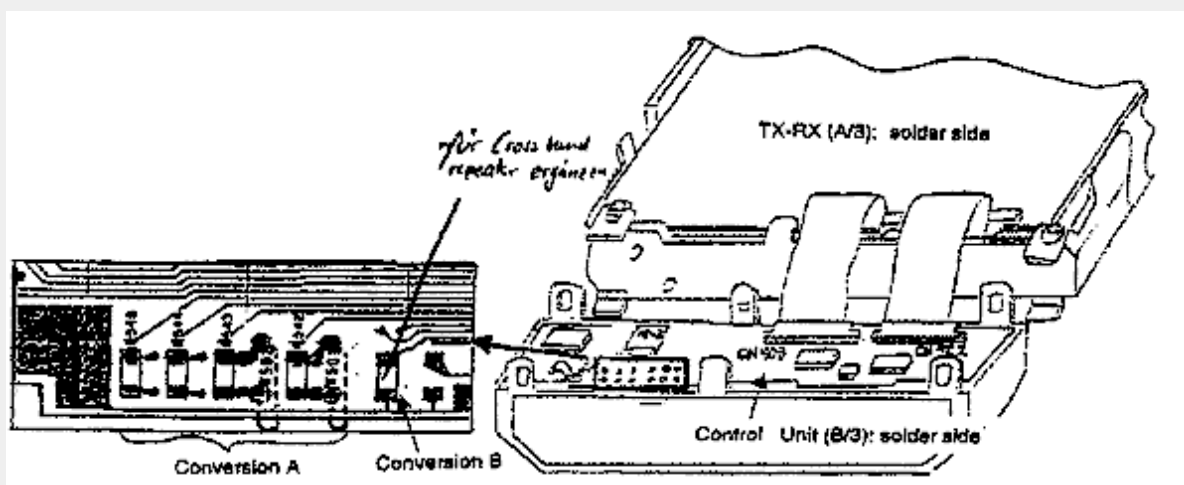

Conversion A Reception wide band (Already dealt with for M destinations)
 E destination Eliminates mounted chip jumper resistor R542 (0 ohm).
 K destination Cuts the mounted jumper wire (W501).
 Conversion B Repeater/answer back (Already dealt with for K destinations)
 Chip jumper resistor 0 ohm added (R92-0670-05)
 * The chip removed in Conversion A can be used in Conversion B.
 * When adding or eliminating the chip jumper resistor, be careful not to peel off any printed circuit pattern and not to harm any other parts.

2. Contents of settings by destination

For the list of contents of settings for each destination, see (Appendix tables 1 - 5).

This modification is read 1671 times.

[top of page](#)

28-10-2001

(TM-V7E) Computer interface for TM-V7A&E

Author: Jann DG8NGN - jann@gmx.de. MODIFICATION.NET

To program your memories of the Kenwood TM-V7 you need this interface. The software is downloadable at Kenwoods Webpage www.kenwood.net, or [here](#). Download the MV7101.EXE file. The software can only communicate with serial port 1 or 2!
mods.dk/manuals/kenwood/TM-V7_MCP-V7_Version_1.01_Memory_Control_Program.zip

Parts list. R1/R6 = 150 Ohm
 R2 = 22 Kohm
 R3 = 10 Kohm
 R4 = 33 Kohm
 R5 = 15 Kohm
 C1/C2 = 1uF/16V
 D1 = 5,1 V Zenerdiode
 D2/D3 = 1N4148 or equal
 T1 = BC558A or equal
 T2 = BC337 or equal

Schaltplan PG-4S Kabel für Kenwood TM-V7 und TM-G707

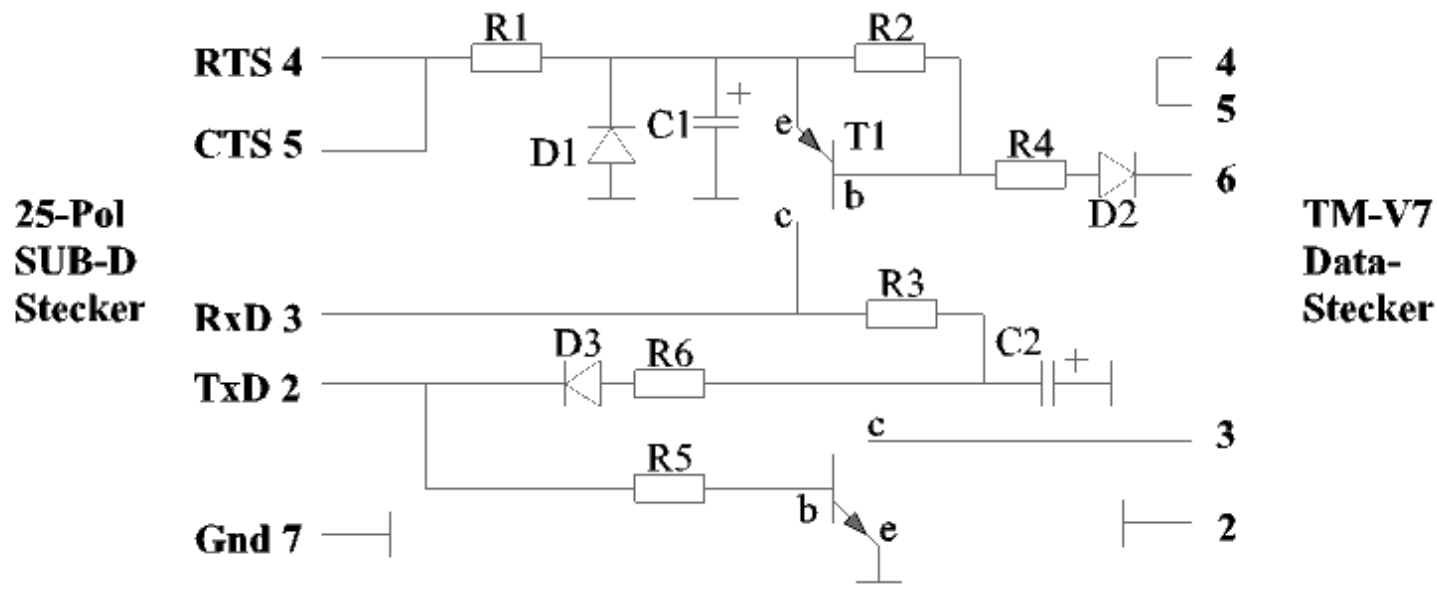

Platinenlayout für PG-4S-Adapter im SUB-D 25-Pol-Gehäuse:

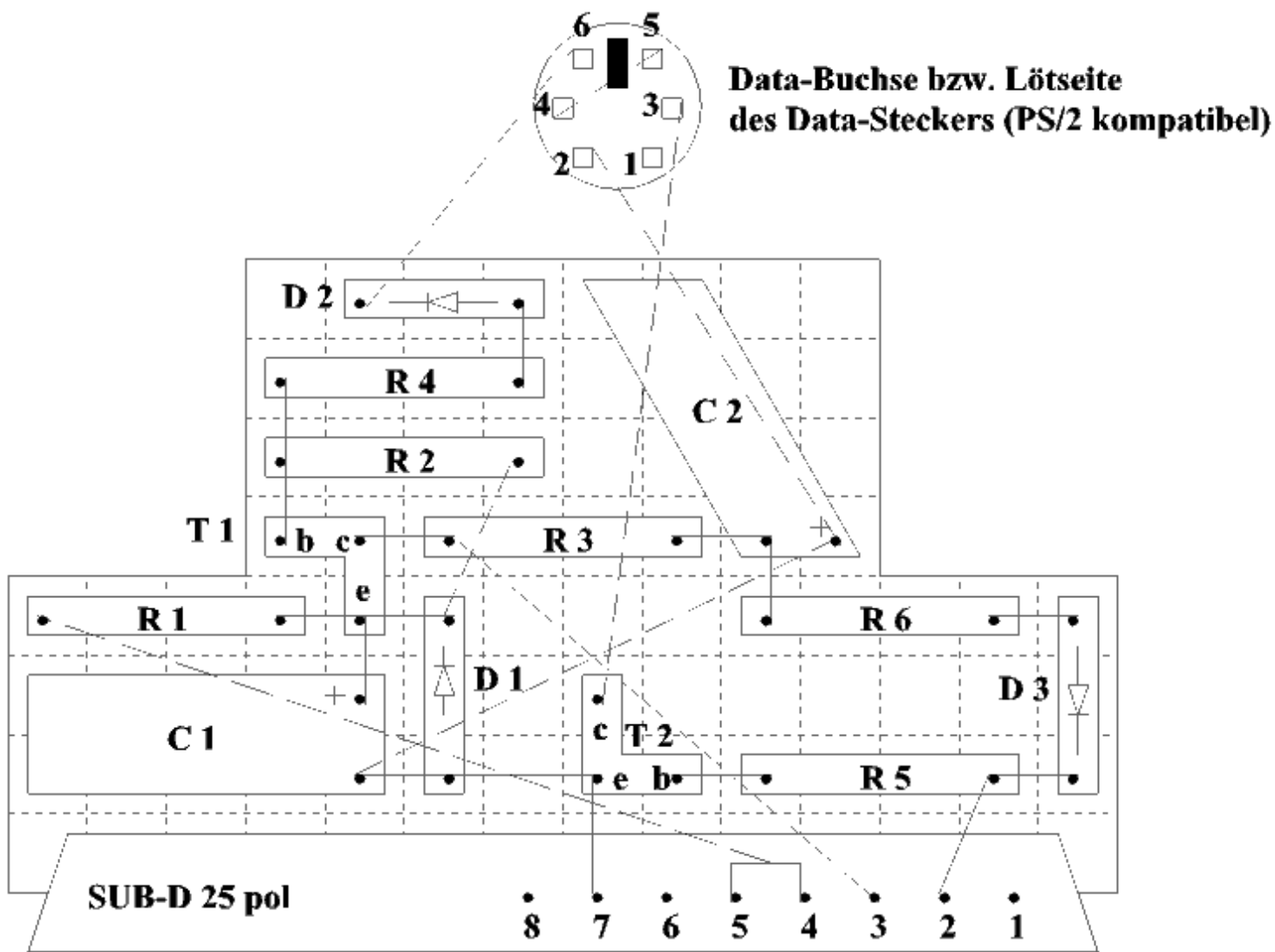

by DG8NGN Jann (jann@gmx.de) and DO1NK Karin. Special thanks to DB8KY.

Symbolerklärung:

Linien:

verlötet _____
verkabelt - - - - -

Transistoren Draufsicht (Beinchen unten):



This modification is read 1755 times.

[top of page](#)

19-07-1998

(TR-2200) Service notes on TR-2200A

Author: Trio-Kenwood Communication, inc.

Service bulletin no. 22 (31-10-1977)

TRANSMITTER

1. No TX RF output: Bad 2SC1169 Q9 on X56-1210-11.
2. No TX: Shield plate touching to circuit board under Q8 driver 2SC741.
3. No TX: Open D2 MI301 on X5501130-01.
4. No TX: Repair broken RCT line from crystal deck to TX oscillator.
5. No TX: Bad Q13 2SA562Y. No T13 voltage on TX X56-1210-00.
6. No modulation: Bad D4 1s1658 on X56-1210-11.
7. No TX: Capacitor C21 lead touching to ground at Q4 on X56-1210-11.
8. No TX: No collector voltage to Q7 Q8. Bad Q15 2SC735 Hi/Low control for Q14 on X56-1210-11.
9. TX distortion: Check D3 Zener 9 volt supply regulator for TX low level stages on X56-1210-11.

GENERAL Note On TR-2200A

1. Battery plate overheats: If the red and yellow leads of the external DC cord are connected together, the battery plate will overheat.

RECEIVER

1. Receive Sensitivity poor: Bad 10.245 MHz xtal on X55-1130-11.
2. Receive Sensitivity poor: Bad MI301 D4 on X56-1080-00.
3. Receive Sensitivity poor: Bad Q1 3SK41L on X55-1130-11.
4. No battery operation: Miscontact of internal switch in power jack.
5. No C9 B+ to receiver: Bad Q12 2SC496 on X56-1210-11.
6. Batteries will not charge: Check for a shorted battery plate.
7. Low Rx sensitivity: Bad D3 1S2588.
8. No squelch: Check Q15 2SC458 on X55-1130-11.
9. Poor squelch when cold: Replace D14-16 1N60.
10. No audio: Bad audio IC NPC575 Q16 on X56-1210-11.

This modification is read 547 times.

[top of page](#)

Author: Trio-Kenwood Communication, inc.

Service bulletin no. 11 (13-1-1977)

We have had several inquiries about adapting the TR-2200A whip antenna to the Drake TR-22C and Trio TR-2200. We now have a kit of parts to do this. Following is a copy of the instruction sheet supplied with each kit.

TR-2200 Antenna Kit Instructions

No.	Part Name	Part Number	Qty
1	Whip Antenna	T90-0082-05	1
2	Antenna Connector	J32-0230-04	1
3	Washer	N19-0282-04	2
4	Insulating Ring	N19-0283-04	2
5	Antenna Lug	E23-0097-04	1
6	Nut	N14-0116-04	1
7	Pipe	F29-0018-14	1
8	Ground Lug	E23-0015-04	3
9	Screw	3x6 mm	1
10	Cable with Lapacitor		1

1. Remove original antenna.
2. Enlarge antenna hole to 9.5 mm.

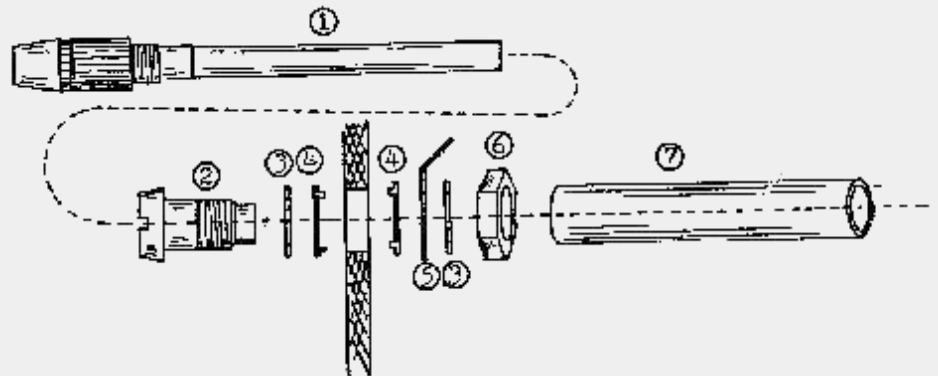

3. Install parts 1 thru 8 as shown in the exploded view below.
4. Remove coaxial cable that runs from the original whip antenna th the SO-239.
5. Connect original coaial cable from terminals ANT and E to the external antenna connector (SO-239). (This cable originally went from terminals ANT and E to the whip antenna.)
6. Locate the 2 "L" brackets mounting the TX unit to the side and install 2 ground luge between the bracket and the side out the unit.
7. Install the coaxial cable so that the end with the capacitor is aat the SO-239.
8. Solder the free end of the capacitor to the center pin of the SO-239 and solder the coax braid to the ground terminal.
9. Mount the last ground lug with 3x6 mm screw at the hole next to the whip antenna.
10. Solder the braid of the supplied coax to the ground lug instalkled in Step 9 and the center conductor of the coax to the antenna lug 2.
11. Carefully solder the coax braid to the 2 lugs installed in Step 6. (See diagram below.)

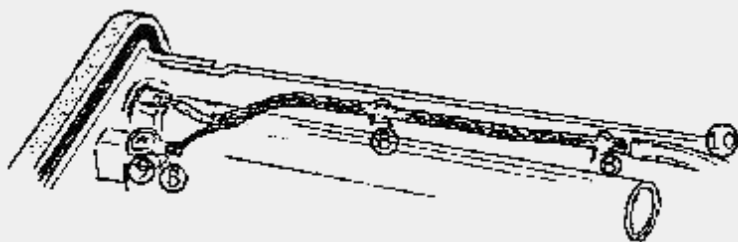

19-07-1998

(TR-2400) TR-2400 Volume Control Replacement

Author: Trio-Kenwood Communication, inc.

Service Bulletin no. 819 (20-3-1980)

When replacing the volume control in a TR-2400, certain precautions should be observed to insure against inducing new problems to either the control or the radio.

When installing a replacement volume control R05-2409-05, solder the leads to the potentiometer sparingly, to prevent flux or solder from running down the tabs and into the joint between the tab and the deposited resistance material. If this precaution is not observed, future failure of the new control is possible.

Secondly, when reassembling the radio, tape insulate the PCB ground paths directly adjacent to the power switch tabs on the volume control. This will prevent accidental shorting of the battery to ground, and loss of the B+ RF choke, L101.

Note:

Reference page 2, Service Bulletin #808, issued 2/12/80 for a picture of the PCB/Vol control insulation.

This modification is read 463 times.

[top of page](#)

19-07-1998

(TR-2400) TR-2400 Battery Charger Failure

Author: Trio-Kenwood Communication, inc.

Service Bulletin no. 822 (22-4-1980)

The stock charger (W09-0307-05) supplied with the TR-2400 may be repaired and/or tested as necessary.

Open circuit, the charger should deliver 18-20V. Current when charging should be 45mA.

Contained in the charger, in series with the output is a 120 ohm 1/2 watt current limiting resistor. Under normal use (including momentary short circuit test) this part should not fail.

If you receive a charger with no output, the unit may be opened by fracturing the glued seam by a sharp moderate hammer blow. Place the charger on its side on a hard, flat surface. A layer of cloth at top and bottom will protect the case from marring. Strike the seam first on one side, and then the other. The case should open in two pieces.

Replace the 120 ohm 1/2 W resistor with a 1 W resistor. After replacing and before closing the unit, perform voltage and current checks. A spot of glue or cement at each corner will reseal the charger.

This modification is read 473 times.

[top of page](#)

19-07-1998

(TR-2400) Speaker Mic for TR-2400

Author: Trio-Kenwood Communication, inc.

Service Bulletin no. 864 (20-3-1983)

The SMC-25 Speaker Microphone may be adapted for use with the TR-2400 by performing the following:

Parts Required:

Qty	Part No.	Description
1	E30-1628-08	SMC-24 Cable Assembly
1	J42-0429-08	SMC-25 Bushing

Procedure:

1. Remove the three chrome and one black Phillips head screws from the microphone case.
2. Separate the case halves and remove the PTT switch, the microphone and the speaker assembly.
3. Carefully pry the brass clamp from the SMC-24 cable assembly, and remove the hard rubber bushing.
4. Slide the SMC-25 bushing (J42-0429-08) onto the cable and replace the brass clamp.
5. Remove the SMC-25 cable assembly from the speaker, PTT switch and the microphone. Leave the small resistor (Parallel cap on some models) connected to the mic element for now. Also save the small black and the small brown wire from the SM-25 Cable.

6. Solder the white wire from the SMC-24 cable to one side of the resistor on the mic element and the small brown wire to the mic element at the other side of the resistor. The resistor and capacitor may now be removed.
7. Assemble the remaining components: Short black wire to center pin of PTT switch, red wire to switch common, Blue wire to one side of the speaker, and the remaining wires to the other side of the speaker (1 short brown, one long brown, and one short black).
8. Replace the back cover, and lapel clip, to complete the procedure.

Note: This change may be performed at the owners option and may not be performed in warranty.

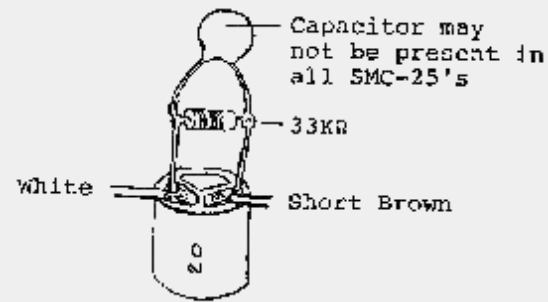

Figure 1

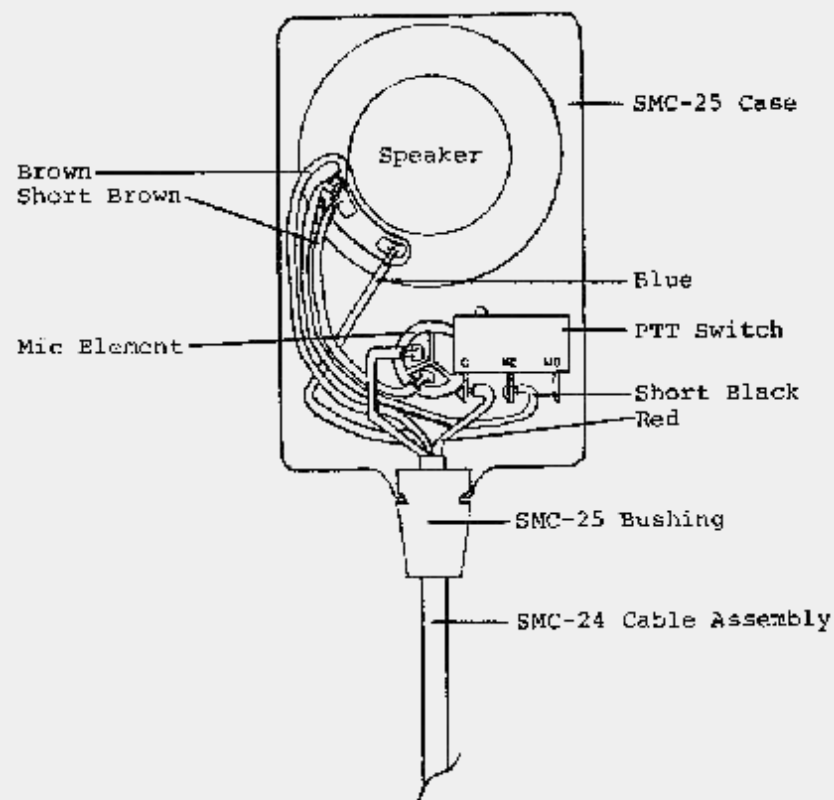

Figure 2

This modification is read 476 times.

[top of page](#)

19-07-1998

(TR-2400) TR-2400 Tone Encoder RFI

Author: Trio-Kenwood Communication, inc.

Service Bulletin no. 58 (14-12-1979)

In some cases, users may report RF interference, or motor-boating, when using a tone encoder in their TR-2400. A secondary complaint of excessive tone level may also be encountered.

1. For RFI, bypass the B+ terminal to ground with a 100 uf cap.
2. For excessive tone input to the TR-2400, install a 100 K ohm resistor between the encoder and the TR-2400 Tone input terminal.

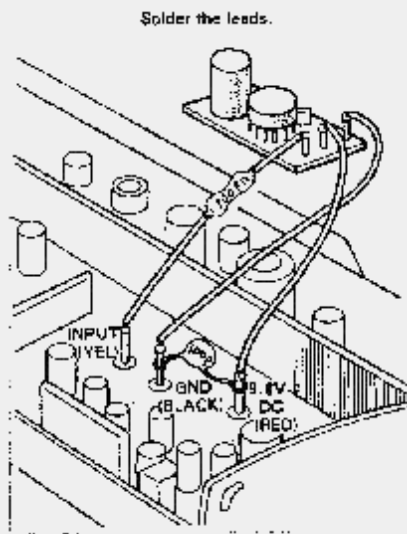

This modification is read 459 times.

[top of page](#)

19-07-1998

(TR-2400) TR-2400 Unwanted Noise: Tone or burst at TX

Author: Trio-Kenwood Communication, inc.

Service Bulletin no. 809 (13-2-1980)

For complaints of a tone burst type noise, or simply a noise, at initial key down, suspect either a broken loose component, or incorrect valued component on the RX TX unit.

On the RX TX unit, Q16 emitter, check C82, a 33 uf tantalum cap for broken connection.

If you find a 22 uf cap at C82 replace it with a 33 uf cap.

This modification is read 448 times.

[top of page](#)

19-07-1998

(TR-2400) TR-2400 Display or Keyboard trouble

Author: Trio-Kenwood Communication, inc.

Service Bulletin no. 810 (20-2-1980)

Display

An intermittent or blank digit may be caused by either a broken lead, or intermittently shorting lead on the PLL unit.

On the PLL unit, look in the area of Q12, the touchtone generator. Between Q12 and the board edge locate the D1-D4 lines. Inspect this area for either an open (Broken) lead, or shorted (pinched) lead. Repair as necessary, and check lead dress before reassembly.

Keyboard

An intermittent or inoperative keyboard row or column may be caused by a torn or pinched lead, or a cracked diode.

Again, in the area of Q12, inspect the "T" and "Y" lines for shorts or open connections, and inspect diodes D19-D26 for physical breakage.

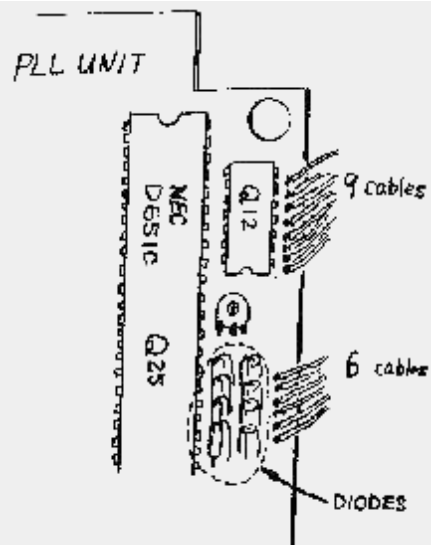

This modification is read 478 times.

[top of page](#)

19-07-1998

(TR-2400) TR-2400 RX low, Intermittent, or distorted

Author: Trio-Kenwood Communication, inc.

Service Bulletin no. 811 (20-2-1980)

For any of the above complaints, suspect a broken loose component in the RX IF or audio output circuit on the RX TX unit. Simply pull up on the leads and resolder.

Adjacent to Q9, the audio output IC, find C49, a 1uf cap. If broken loose from the board, audio output may be down, while current consumption may be up from the normal 30mA to about 100mA due to the audio output amp oscillating.

Adjacent to L10, the discriminator, locate C33, a .033uf cap. If this component is broken loose, audio output may be up approximately 6 dB with excessive high frequency audio response.

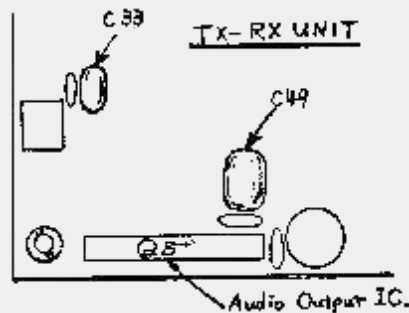

This modification is read 456 times.

[top of page](#)

19-07-1998

(TR-2400) TR-2400 Scratchy TX

Author: Trio-Kenwood Communication, inc.

Service Bulletin no. 818 (20-3-1980)

Complaints of scratch audio, noise when flexing the antenna, or noisy audio when handling the unit during transmit may be remedied by tightening the Printed Circuit Board screws.

To disassemble the unit remove the back cover and battery compartment screws. INSPEC T the VCO shield solder points along the edge and bottom of the PLL board. Resolder if you find a broken solder bond.

Flex the metal frame several times to reseal the board, and retighten the board mounting screws. Be certain the flat metal spring has good tension when installed between the RX TX unit a fram (below the PTT switch).

This modification is read 448 times.

[top of page](#)

18-03-2000

(TR-2400) TR-2400 Optional charge input protection

Author: Trio-Kenwood Communication, inc.

Service Bulletin no. 807 (8-2-1980)

Some users may request addition of a series diode to the Charge Jack to prevent inadvertent shorting of the battery pack if a voltmeter probe, headphone jack, or other conductor accidentally shorts across the external Charge Jack.

This can be used only for the standard wall changer. The optional fast chargers require battery voltage be available at the charge jack as feedback to the charger regulator.

Add a S1 diode in series with the battery charger line, at the Charger Jack. Observe battery polarity, as shown. Charging current will drop approximately 2 mA.

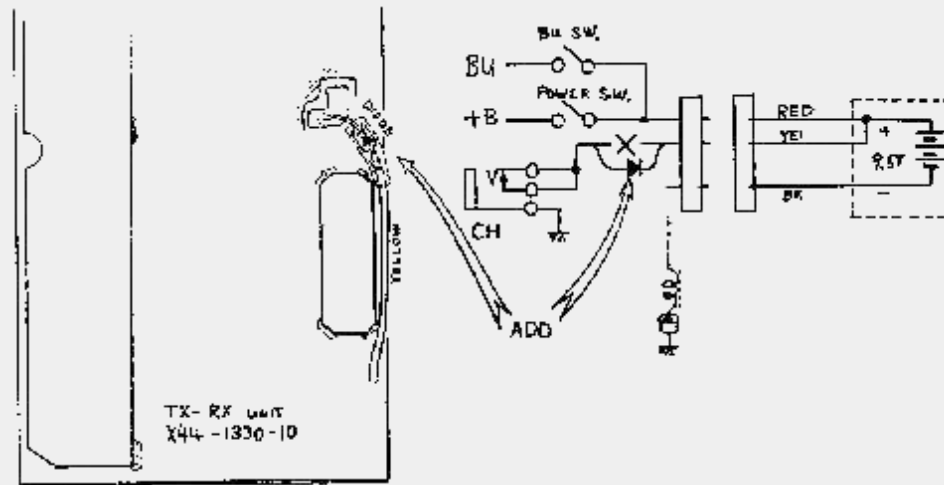

Note:

1. Si diode must be rated at least 200 mA.
2. Install carefully-don't short the YELLOW B+ lead when reassembling.

This modification is read 454 times.

[top of page](#)

18-03-2000

(TR-2400) TR-2400 Offset failure

Author: Trio-Kenwood Communication, inc.

Service Bulletin no. 808 (12-2-1980)

For intermittent or no offset, suspect as intermittent abort between the metal body of the REV NOR SW and an adjustment jumper on the PCB, or intermittent contact between the volume control metal body and the PLL PCB.

1. Disassemble the radio and inspect the board to the right of the REV/NOR SW. Using a small flat blade screwdriver or similar tool, gently pry the short metal jumper and the metal body switch tab apart. This should clear the offset trouble. (Fig.1)

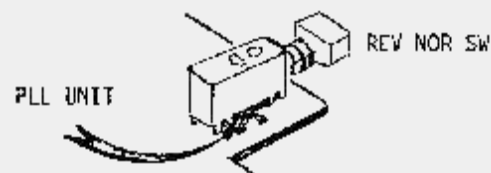

2. Run a strip of cloth tape (nul vinyl tape) approximately 1/2 inch wide, across the top edge of the Display unit directly under the volume control. This will prevent the control using from intermittently touching the PCB and causing loss of offset functions. In similar manner, add insulation as shown at "B" and "C". (Fig.2)

DISPLAY UNIT
X54-1480-10

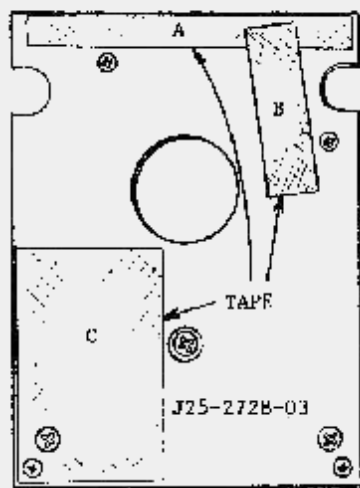

3. When reassembling, make certain the PLL unit does not inadvertently ground the power switch tab. (Fig.3)

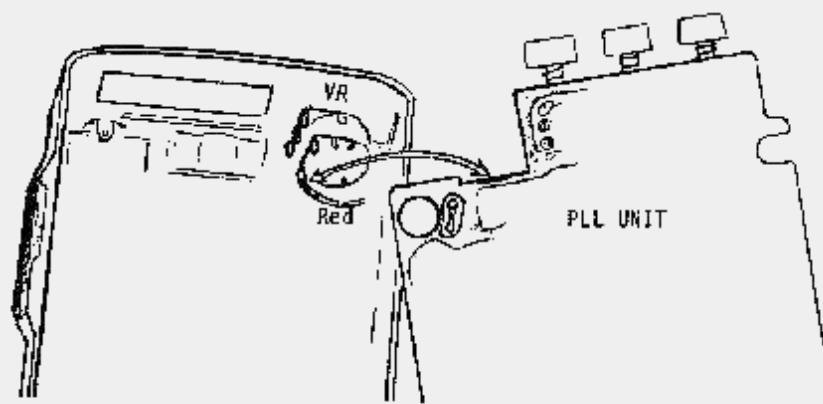

This modification is read 457 times.

[top of page](#)

19-03-2000

(TR-2400) TR-2400 unlock

Author: Trio-Kenwood Communication, inc.

Service Bulletin no. 814 (19-2-1980)

For apparent unlock, or either RX or TX failure, suspect not PLL unlock, but low RX or TX XTAL activity. Adding or replacing circuit components and returning the oscillator will cure the problem.

For NO RX

Suspect low XTAL activity for X3 on the RX unit. At Q1, add 7-12pF Base to Emitter. At Q5 replace L5, 22uH with a 15uH with choke, L40-1501-05. Adjust TC1 for 42.6 MHz in RX.

For NO TX

Suspect low XTAL activity for X2. At Q4, add 7-12pF Base to Emitter. Replace L15, 22uH with a 15uH choke. L40-1501-05. Adjust TC2 for exact 146MHz transmit frequency. At the base Q4, also check L2 for intermittent shorting against the Display unit mounting screw.

This modification is read 483 times.

[top of page](#)

19-03-2000

(TR-2400) TR-2400 pulse noise

For elimination of pulse type noise, either in receiver, include by the LCD oscillator, or in transmit, inducted by stray RF in the H.T., install additional chokes and a capacitor as detailed.

Disassembly:

1. Disconnect the battery pack and remove from the unit.
2. Remove the 4 case screws, plus two battery pack compartment screws.
3. Separate the front and rear halves of the radio. **Do not tear wires!**
4. Unscrew two screws and two threaded retainers holding the PLL unit X50-1640-10. Slide the unit down to clear the three push switches from the top panel.
5. Separate the PLL and RX/TX unit. Remove the fish paper insulation from between the two boards.

TX RF noise:

1. On the RX/TX unit, locate the battery ground (BLACK) lead soldered to the right edge of the PCB. Desolder this line and install a choke with ferrite bead L33-0632-05. Resolder along the bottom edge of the board, as shown.
2. Also on the RX/TX unit, locate the YELLOW lead attached to the foil side of the charge jack J1. Install a .001uF capacitor across J1 to ground as shown.

TX or RX LCD pulse noise:

1. On the display unit X54-1480-10 locate the YELLOW lead marked B+. Resolder this lead and install a 1uH choke L40-1032-03 in series. Lead dress MUST be as shown for physical clearance.
2. Also on the Display unit, adjacent to the B+ lead, desolder the GREEN E (earth) lead and the BLACK E lead, and wire as shown to another 1uH choke, L40-1021-03. Again, observe physical parts placement for clearance.
3. For reassemble, reverse step 5 through 1. If components were installed as specified, there will be no clearance problems.

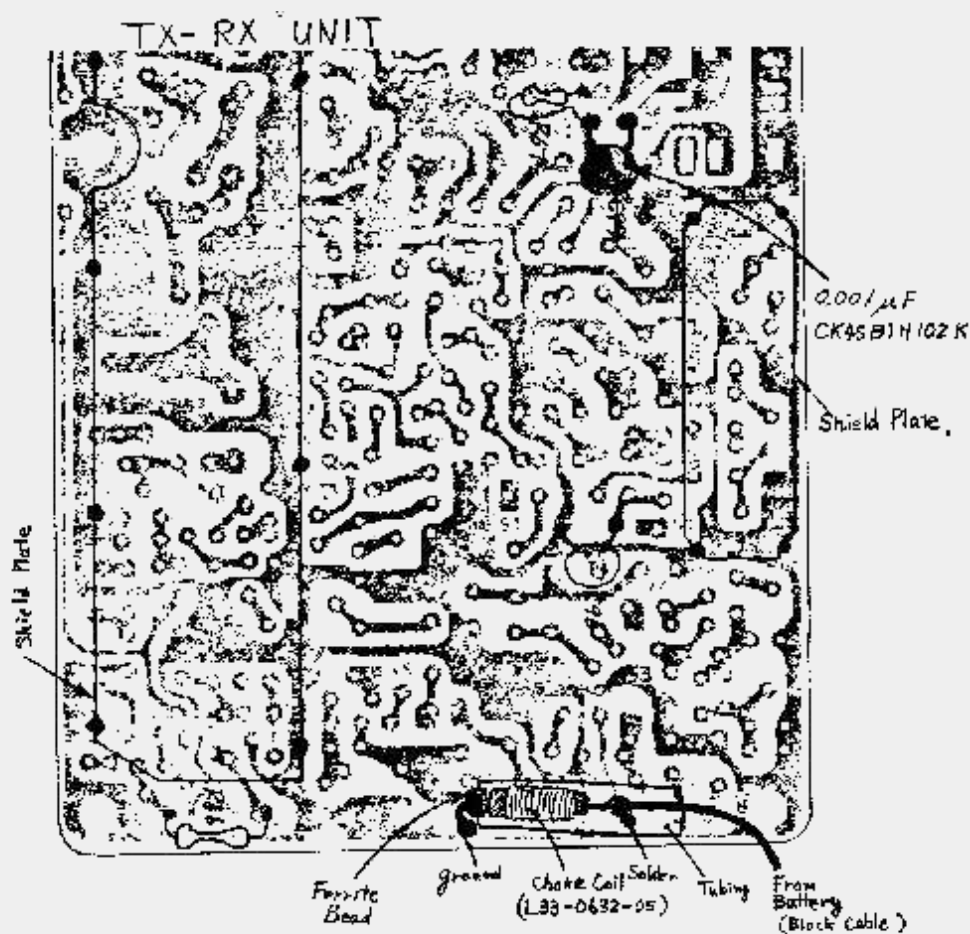

LCD NOISE

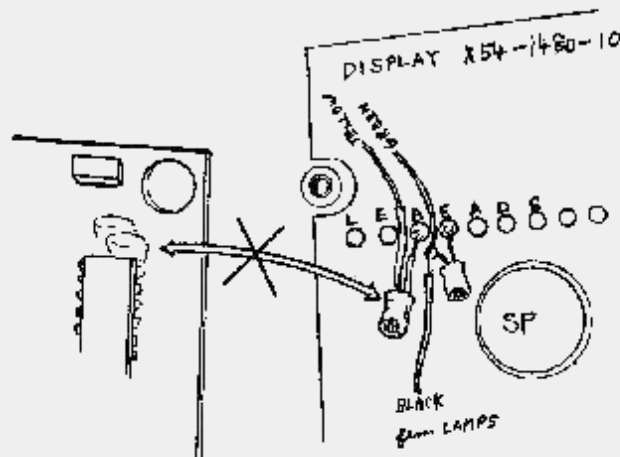

**19-03-2000
(TR-2400) TR-2400 TX noise**

Author: Trio-Kenwood Communication, inc.

Service Bulletin no. 830 (31-7-1980)

Some units may exhibit excessive background noise (up to several hundred Hertz deviation). This may be reduced or eliminated by installing an additional shield between the Display and PLL units.

This changes applies only to units between serial numbers 011xxxx and 101xxxx. Radios before this group (with a momentary REV switch) will not show improvement by addition of this shield. Refer to Service Bulletin #815 for this early group.

Units appearing with serial numbers after 101xxxx will have this shield factory installed.

Parts supplied:

- N09-0627-05 Pan head screw 3 pcs.
- F10-1627-05 Shield w/lead 1 pcs.

1. Remove 4 rear case screws, and 2 screws from inside the battery compartment.
2. Sperate front case body. DON'T tear leads.
3. Remove 2 small and three large screws from the bottom edge of the Display unit. Save the two small screws.
4. Installing the three pan head screws in place of the round head screws.
5. Install the shield foam towards the Display. Lift the protective plastic only enough to secure the shield with the two small screws. Cover the screw heads with the plastic film.
6. Secure the shield ground under the small Philips screw located between the BUSY/OPEN and S TONE switches.
7. When reassembling, the wiring harness must be positioned to the right of crystal X2 (44.1666MHz) or the case will not close correctly, and wires will be pinched.
8. Close the case and reinstall 6 screws.

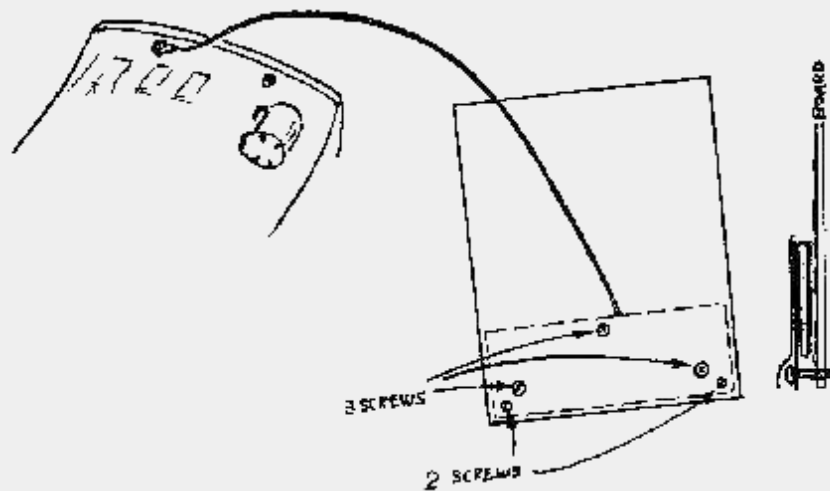

Installation time for this shield is approximately ½ hour.

**19-07-1998
(TR-2500) TR-2500/3500 dip switch setting**

The following is a list of the Dip Switch settings for the Kenwood TR-2500/3500. It is mainly intended for those who have the radio but lack the info.

1=ON
0=OFF

FREQUENCY	SWITCHES					
-----	1	2	3	4	5	6
67.0	1	1	1	1	1	1
71.9	1	1	1	1	0	1
74.4	1	1	1	0	1	1
77.0	1	1	1	1	0	0

79.7	1 1 0 1 1 1
82.5	1 1 1 0 0 1
85.4	1 1 0 0 1 1
88.5	1 1 1 0 0 0
91.5	1 0 1 1 1 1
94.8	1 1 0 1 0 1
100.0	1 1 0 1 0 0
103.5	1 1 0 0 0 1
107.2	1 1 0 0 0 0
110.9	1 0 1 1 0 1
114.8	1 0 1 1 0 0
118.8	1 0 1 0 0 1
123.0	1 0 1 0 0 0
127.3	1 0 0 1 0 1
131.8	1 0 0 1 0 0
136.5	1 0 0 0 0 1
141.3	1 0 0 0 0 0
146.2	0 1 1 1 0 1
151.4	0 0 1 1 0 0
156.7	0 1 1 0 0 1
162.2	0 1 1 0 0 0
167.9	0 1 0 1 0 1
173.8	0 1 0 1 0 0
179.9	0 1 0 0 0 1
186.2	0 1 0 0 0 0
192.8	0 0 1 1 0 1
203.5	0 0 1 1 0 0
210.7	0 0 1 0 0 1
218.1	0 0 1 0 0 0
225.7	0 0 0 1 0 1
233.6	0 0 0 1 0 0
241.8	0 0 0 0 0 1
250.3	0 0 0 0 0 0

73s from Alan
N6QOG @ K6RAU.#NOCAL.CA.USA.NA.

This modification is read 640 times.

[top of page](#)

08-04-2000

(TR-2500) TR-2500 RX IMD Improvement

Author: Trio-Kenwood Communication, inc.

Service Bulletin no. 858 (24-5-1982)

RX intermodulation distortion may be improved by reducing second conversion oscillator harmonic content and level. No adjustments are required. This may be applied to a unit specifically exhibiting out-of-band intermodulation distortion. It is, however, not a general improvement.

On the TX RX unit X44-1460-xx, perform the following changes:

R55	from	47 Kohm		delete
C73		47pF	to	33pF (CC4SSL1H330J)
C74		100pF		150pF (CC4SSL1H151J)

Add a shield between Q1, (R3, C5) and C73 (from L1 to near X1).

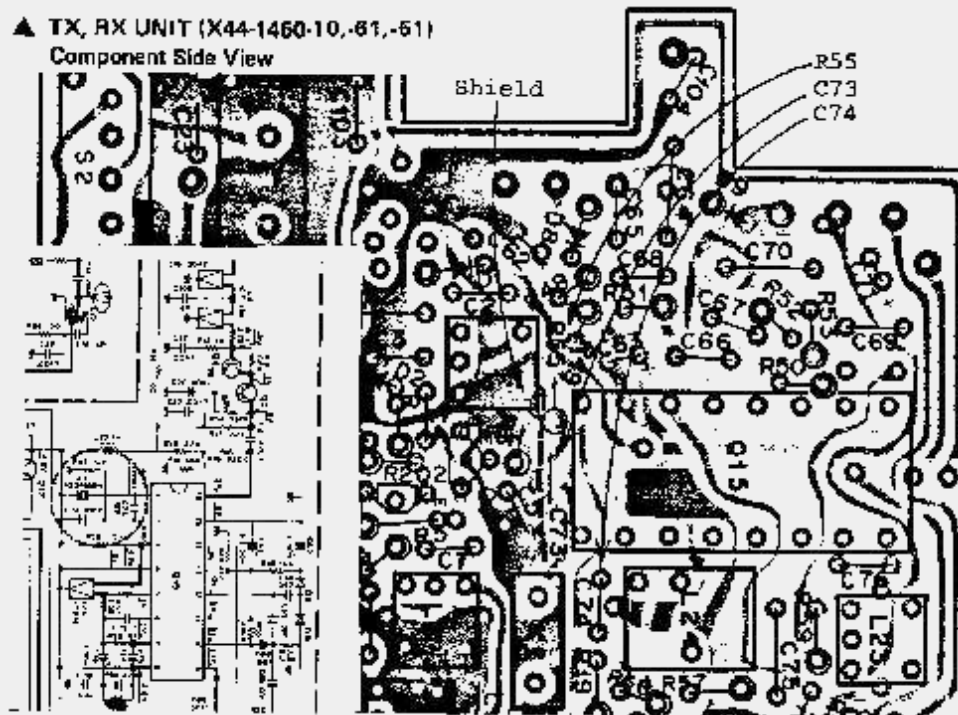

These changes are at the owner's option, and may not be installed in-warranty.

Note: The information presented is complete and accurate to the best of our knowledge. However, Trio-Kenwood Communications assumes no liability either for your work, or for consequential damage resulting from your work.

This modification is read 636 times.

[top of page](#)

19-07-1998

(TR-2600) Extended frequency TR-2600A

Here is some info on the kenwood model tr-2600a handie - talkie....

If you want to be able to transmit on the extended freq area then do the following mod....

1. Remove the front cover of the radio
2. Locate the ic chip in the lower right hand corner.
3. Find the 2 diodes number d32 and d33 (they should be the top two on the right side of the ic chip, also they have ben cut beforehand (re-soldered)
4. Un-solder the two diodes (breaking their connection).
5. Replace the front ctver.
6. Re-install the battery and turn the unit on, then push the reset button on the back.

The tr-2600a should now be reprogramed and it should also transmit anywhere it will recieve...

I forgot to add that d32 and d33 on the recieve board (but that is what is under the front cover).

Jim - KDOPJ

This modification is read 545 times.

[top of page](#)

19-07-1998

(TR-2600) TR-2600A PLL Unlock Troubleshooting

Author: Trio-Kenwood Communication, inc.

Service Bulletin no. 901 (18-10-1985)

The owners manual for the TR-2600A lists the lithium battery as a possible cause of the display showing UL. You may wish to check the battery, but realistically on a new radio this is probably not the reason for the unlock condition.

If the radio showl UL when first turned on you should perform the following test. This will help you to isolate the symptom:

1. With the radio turned OFF, press and hold the 5 key, and then turn on the radio. Release the 5 key. If the display shows a frequency indication you may have a pad X2 on the TX unit.
2. If there is no frequency display other than UL then proceed with step II.

3. You may also wish to check crystal X1 the Reference oscillator (10.240 MHz at pin 16 or 17 of IC1.)

There are several other points to check.

1. Check trimmer capacitors TC , TC5 and TC6. If you press on the trimmer and the UL dissappears replace the trimmer.
2. Check pin number 18 of IC1, it should be 5.4 - 6 vdc.
 - a. If the voltage is over 6.5vdc replace Q17, Q18, and IC1.
 - b. If the voltage is less than 5vdc replace Q17 and Q18.
3. Check the CLK signal at the flex pc board connector, and pin 10 of IC1.
 - a. The CLK signal should be aprox 4 - 4.4 vdc.
Pin 10 should be aprx. 0 - .2 vdc.
 - b. If pin 10 is high check Q16, and for cold soldering on the flexible pc board between the keyboard and the RX unit.
4. Check the alignment of the PLL section, as given in the Service manual.
5. Press the RESET pushbutton on the back of the radio.

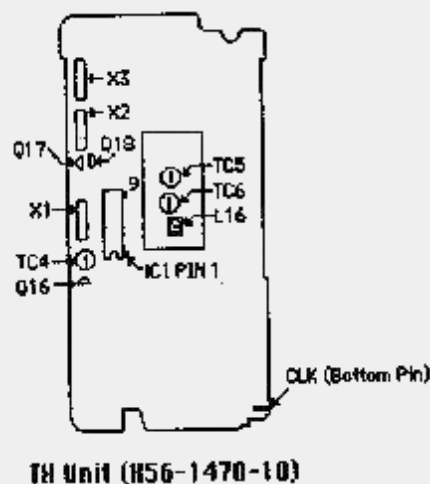

Time required for this modification is 1/2 hour or less.

This modification is read 486 times.

[top of page](#)

19-07-1998

(TR-2600) How to fix TR-2600 keypad

I have a TR-2600, and a few years ago the keypad failed. The symptom was that buttons in one column of the pad did not work. I opened the radio up hoping to find a loose wire that I could re-attach--no such luck.

The "keypad" is a PC board mounted directly behind the buttons. There are several diodes (and little else) on the board. I checked the diode closest to the affected buttons, and it had failed. Once it was replaced with a garden-variety switching diode, the radio worked fine. So, a new keypad may not be necessary. I hope this helps.

This modification is read 472 times.

[top of page](#)

15-04-2000

(TR-2600) TR-2600A PLL unlock

Author: Trio-Kenwood Communication, inc.

Service Bulletin no. 903 (14-1-1986)

Some cases of PLL on the TR-2600A may be caused a failure of the crystal oscillator circuit X2, X3, and Q13. This may be corrected by performing the following changes.

On the TX unit (X56-1470-10)

Replace Diodes D13, and D14 (MA856) with a series pair of BA282's as shown in the diagram below. Also change resistor R54 to 47 ohm as shown.

Parts required:

BA-282 diode, 4 each.

47 ohm chip resistor (RD73FB2A470J), 1 each.

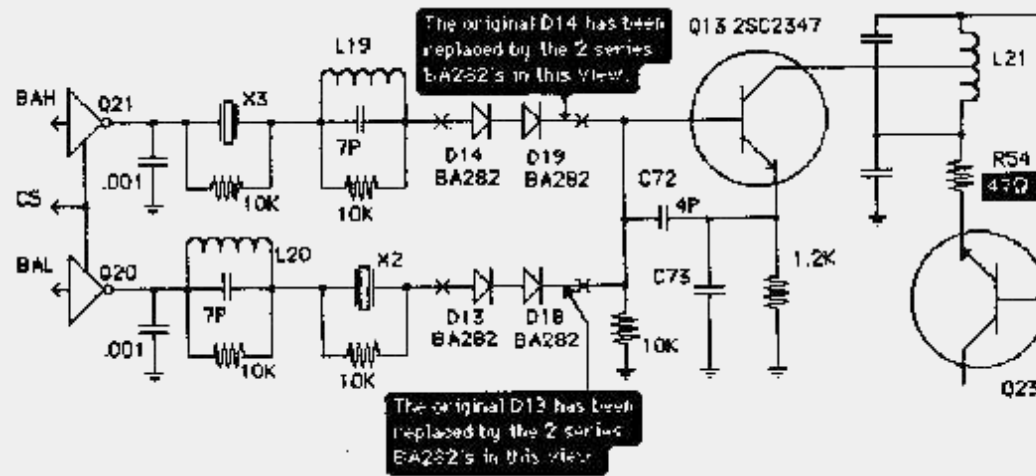

This change is applicable to serial numbers before SN 702xxxx.

Time required for this modification is 1 hour or less.

This modification is read 488 times.

[top of page](#)

19-07-1998

(TR-3500) TR-2500/3500 dip switch setting

The following is a list of the Dip Switch settings for the Kenwood TR-2500/3500.

It is mainly intended for those who have the radio but lack the info.

1=ON
0=OFF

FREQUENCY	SWITCHES					
	1	2	3	4	5	6
67.0	1	1	1	1	1	1
71.9	1	1	1	1	0	1
74.4	1	1	1	0	1	1
77.0	1	1	1	1	0	0
79.7	1	1	0	1	1	1
82.5	1	1	1	0	0	1
85.4	1	1	0	0	1	1
88.5	1	1	1	0	0	0
91.5	1	0	1	1	1	1
94.8	1	1	0	1	0	1
100.0	1	1	0	1	0	0
103.5	1	1	0	0	0	1
107.2	1	1	0	0	0	0
110.9	1	0	1	1	0	1
114.8	1	0	1	1	0	0
118.8	1	0	1	0	0	1
123.0	1	0	1	0	0	0
127.3	1	0	0	1	0	1
131.8	1	0	0	1	0	0
136.5	1	0	0	0	0	1
141.3	1	0	0	0	0	0
146.2	0	1	1	1	0	1
151.4	0	0	1	1	0	0
156.7	0	1	1	0	0	1
162.2	0	1	1	0	0	0
167.9	0	1	0	1	0	1
173.8	0	1	0	1	0	0
179.9	0	1	0	0	0	1
186.2	0	1	0	0	0	0
192.8	0	0	1	1	0	1
203.5	0	0	1	1	0	0
210.7	0	0	1	0	0	1
218.1	0	0	1	0	0	0
225.7	0	0	0	1	0	1
233.6	0	0	0	1	0	0
241.8	0	0	0	0	0	1
250.3	0	0	0	0	0	0

73s from Alan

N6QOG @ K6RAU.#NOCAL.CA.USA.NA.

19-07-1998**(TR-3500) Extended frequency TR-2600A**

Here is some info on the kenwood model tr-2600a handie - talkie...

If you want to be able to transmit on the extended freq area then do the following mod....

1. Remove the front cover of the radio
2. Locate the ic chip in the lower right hand corner.
3. Find the 2 diodes number d32 and d33 (they should be the top two on the right side of the ic chip, also they have ben cut beforehand (re-soldered)
4. Un-solder the two diodes (breaking their connection).
5. Replace the front ctver.
6. Re-install the battery and turn the unit on, then push the reset button on the back.

The tr-2600a should now be reprogramed and it should also transmit anywhere it will recieve...

I forgot to add that d32 and d33 on the recieve board (but that is what is under the front cover).

Jim - KDOPJ

19-07-1998**(TR-7200) Service notes on TR-7200A**

Author: Trio-Kenwood Communication, inc.

Service bulletin no. 23 (31-10-1977)

Receiver

1. No squelch: Check C84 47uf on X55-1110-11.
2. Intermittant receive: Check for D14 touching to ground on X55-1110-11.
3. Both Q17, Q18 audio transistors burned up: Send for bulletin before replacing.
4. Poor receiver sensitivity: Check for proper output of Q10 10.245 MHz stage. If it is defective replace xtal.
5. No receiver audio noise: Check L23 discriminator coil.
6. No receiver: No C9 voltage at X55-1110-11.
7. Receiver sensitivity poor: Check D2 MI301.

Transmitter

1. Distortion on audio TX: Bad Q8 TA7061 IC.
2. No TX HI: Check for shorting terminals at HI/Low switch.
3. No TX: Check for proper T9 voltage at X56-1190-11.
4. No TX: Collector voltage SB at X45-1080-00. Check Q9 2SA496Y.
5. No TX: Check D1 MI301.

Date: 20-04-2001

From: Jan Steen PA3FTD@Amsat.org.MODIFICATION.NET

The problem, as described for the TR-7200G (distorted mic.signal) can also be applied for the TS-700, which uses the same mic. preamp TA7061.

The signal sounds ugly noisy. The replacement of the preamp was efficient. I discovered it myself and used the preamp from an old 7200.

19-07-1998**(TR-7400) Service Notes on TR-7400A****Author:** Trio-Kenwood Communication, inc.

Service bulletin no. 18 (6-10-1977)

PLL and LED Display

1. No transmit or PLL unlock light on: R-27 shorted to shield at D-1 on VCO Unit (X50-1370-10).
2. LED display changes when pushing on LED boards: Remove LED display boards on display mother board. Trim all wires as close to the circuit board as possible. Insulate the foil side of the board with thin plastic and reinstall.
3. PLL unlock light on: Check for 9 volts at 9V terminal on VCO Unit (X50-1370-10). Check Q10 (2SC496) and zener D5 (WZ-061) on this board.
4. PLL unlock light on and no signal at PI terminal on PD Unit (X50-1380-10): Check for open ferri-inductor L1 in emitter lead of Q1 on VCO Unit (X50-1370-10).
5. PLL unlock light on and no signal at pin 3 of IC4 on PD Unit (X50-1380-10): Check for proper divide down signals on IC10, 5, 6, 7, 8.
6. Digits in display are intermittent or some segments are not properly lit: Reseat the connectors on the Display Unit (X54-1210-10). (Push them with a small screw driver.)
7. PLL unlock light stays on when unit is first turned on or cold: Change R4 on the PD Unit (X50-1380-10) from 470 ohms to 47 ohms.
8. PLL unlock light is on for about 2 minutes when the unit is first turned on and the inputs to IC4 on the PD Unit are ok, but there is no output: Defective IC-4.
9. LED display changes when slightly turning or pressing down on channel select knobs: Check for loose solder connections on the circuit board under the BCD switches. (ON bottom of unit.)
10. One segment of one LED is dim: LED may be defective or the resistor network may not be properly soldered.
11. Speaker howl at high volume levels: Reseal the VCO coil (inside small shield box) on the VCO unit (X50-1370-10). use Q dope or a small amount of Epoxy glue. The VCO must be retuned after the glue dries.
12. -600 KHz offset does not work: Check for open ferri-inductor L1 on PD unit (X50-1380-10)
13. LR frequency cannot be adjusted to meet specifications: Check for proper frequency at TP1 on the PD unit. It should be 2.56000MHz. (Must use a 33 pf capacitor when counting this frequency)

Receiver

1. Receiver sensitivity down 30db: Check voltage at the drain of Q1 (3SK41L) on the RX Unit (X55-1150-10). It should be 7 volts. If it is "0vdc", check for shorted feet-thru capacitor in the helical resonator. It may be necessary to replace the helical resonator.
2. No receive: Check C9 voltage. Q27 (CSC496) on RX unit may be defective.
3. No receive and no C9 voltage: Check Q28 (CSC496) and zener D16 (WZ090) on the RX unit.
4. Intermittent receiver audio: Check for shorted terminals on the volume and squelch controls.
5. Receiver sensitivity down: Check for proper level of LR signal. If down, check diode D-6 (1S2588) on the VCO Unit (X50-1370-10).
6. Receiver audio jumping up and down: Check C59 and C62 on RX unit.
7. No receive or low sensitivity: Check for proper output of 10.245MHz oscillator. The 10.245 MHz crystal may be defective.
8. Intermittent receive: Check discriminator coil L14 on RX Unit. It may be open.
9. Meter lamp out: Replace small lamp (B30-9996-05) as follows:

1. Remove meter
2. Remove wires
3. Remove small circuit board
4. Replace lamp
5. Reassemble

Transmitter

1. No meter indication but output power OK: Check for broken wire at terminal SM1 on the RX Unit.
2. Transmitter intermittent when keyed rapidly: Defective D3 (MI402) on PA unit (X45-1090-10).
3. Position of L2 in PA unit: The proper position of this coil is directly on the collector tabs of Q2 (2N6083). This applies to 45XXXX serial numbers only.
4. Background noise on transmit: Reverse coil L1 on the TX unit (X56-1230-10).
5. RF meter works when first key transmitter and then fails: Check for pinched RF sens wire at coil L7 in PA unit. Widen this coil if necessary.
6. Transmitter off frequency and receiver on frequency: Adjust coil L3 on TX Unit for correct frequency.
7. No RF output: Diode D3 (MI402) in PA unit shorted or improperly soldered. If this diode is replaced, keep the leads as short as possible and build up solder on the foil side of the board.
8. Low output power: Loose connection at TC3 in PA Unit.
9. No RF output and receiver sensitivity down 30db: Diode D2 (MI301) on the PA Unit may be defective. Also check D3 (MI402) on this board. Q1 (3SK41L) on the RX unit may also be defective.
10. Intermittent or no transmit: Check for loose connection at Q15 (2SC908) on the TX Unit. Also check the heat sink for this transistor.

11. No RF output but drive to PA Unit is OK: Check for proper SB voltage. It should be 11 to 12 vdc when transmitting into a 50 ohm load. If it is 0vdc check Q10 (2SC496) on the TX Unit.
12. No Modulation: Capacitor C4 (0.1 ufd tantalum) on TX unit may be open.
13. No modulation: Check for pinched pins at microphone jack.
14. No RF output on one band: Check for proper alignment of potentiometers VR61, 62, and 63.
15. No RF output: L4 not soldered to base of Q4 (2SC458B) in PA Unit.

This modification is read 589 times.

[top of page](#)

13-02-2000

(TR-7400) Arcing in TR-7400A final section

Author: Trio-Kenwood Communication, inc.

Service bulletin no. 10 (13-1-1977)

There may be some cases of arcing to ground beneath coil L-6 at the collector of Q-2 (2N6083) inside the final unit X45-10-90-10. This is due to minute differences in the circuit board trace dimensions and a residue of flux on the board.

If this should occur, remove L-6 and clean all traces of carbon and flux from the circuit board. Resolder the edges of the tracer and remove any flux left from soldering. Modify L-6 as shown:

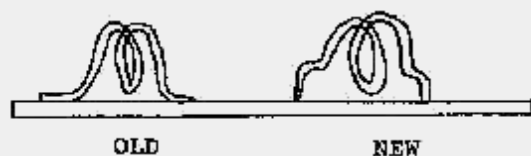

reinstall L-6 and check for rated output. A slight retuning of TC-4 may be required.

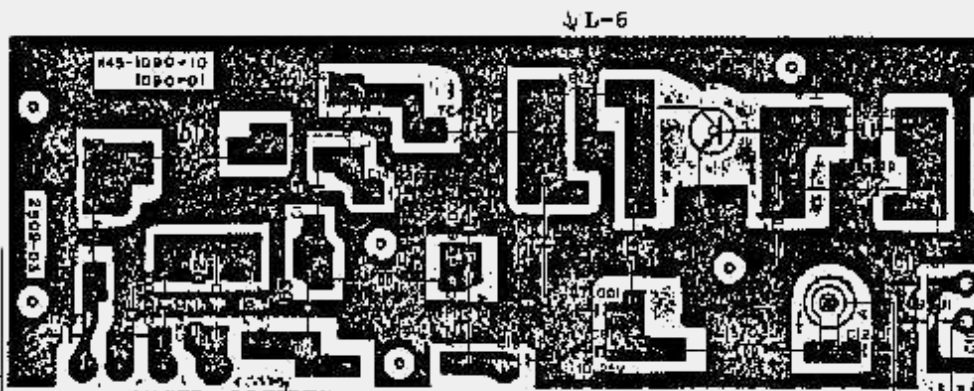

This modification is read 502 times.

[top of page](#)

20-02-2000

(TR-7400) Changes in PO Unit of the TR-7400A

Author: Trio-Kenwood Communication, inc.

Service bulletin no. 32 (19-1-1979)

There was a temporary production change in the PO Unit of the TR-7400A. This change effected the 73XXXX and 74XXXX series units only. The change was made because of the Motorola MC-4016P IC was not available. The Texas Instruments SN74LS192 IC was used as a replacement. It is not a direct replacement, though. It was also necessary to change IC-8 from a TD-3400AP to a TD3404. This series of PO Units is easily recongnized because of the three SN74LS192 IS's are mounted in socket instead of being soldered in place. The PC board was changed to J25-2512-03T instead of J25-2512-03 for this change. The schematic is shown below.

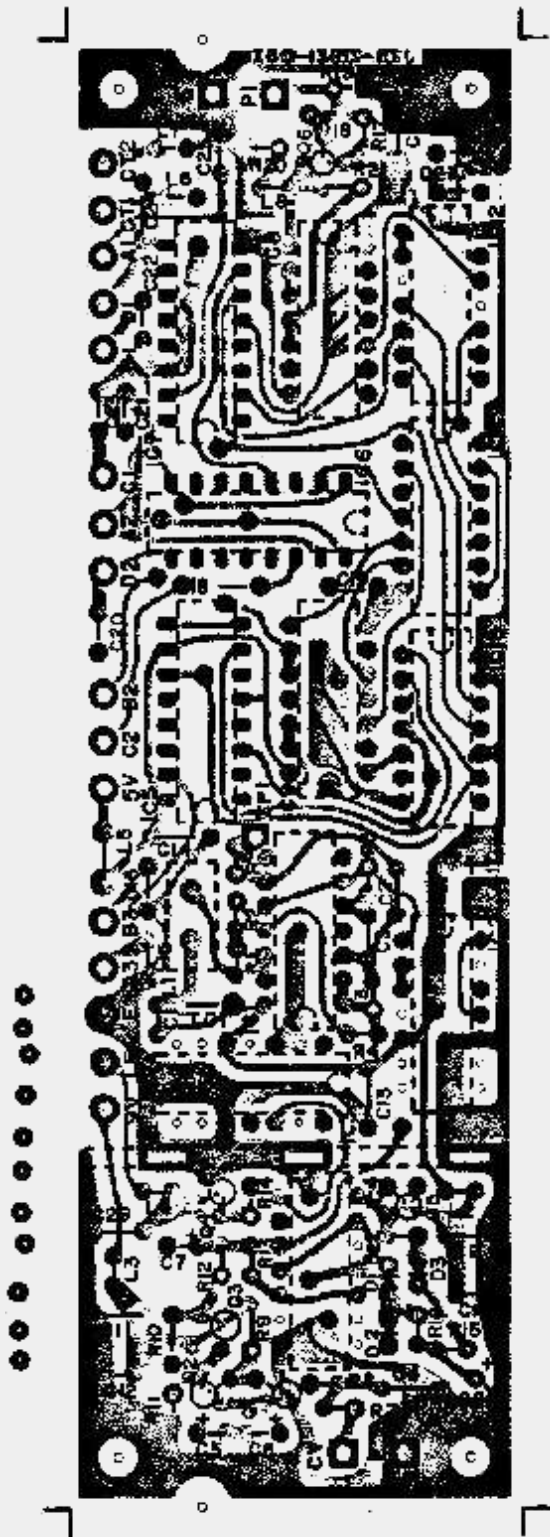
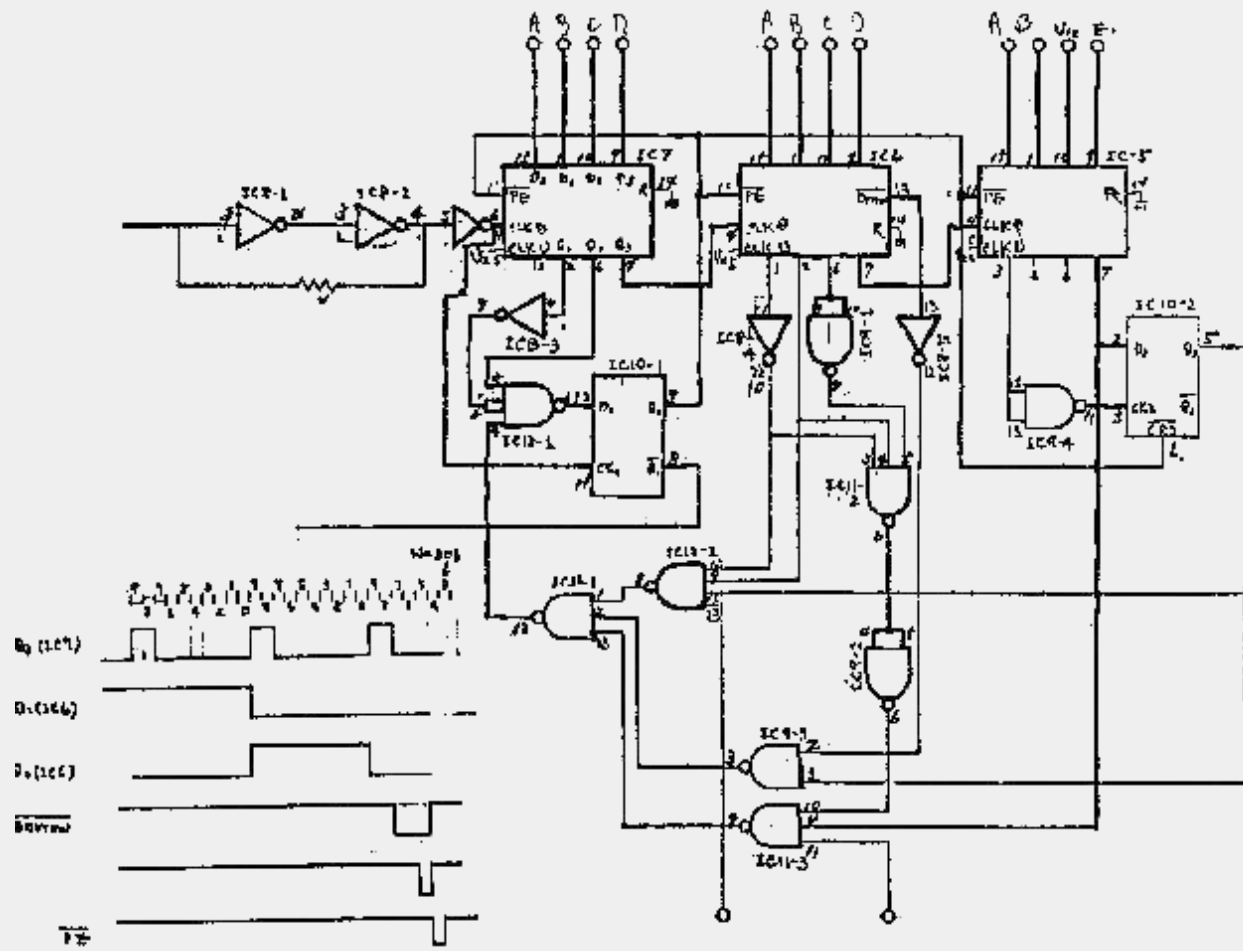

20-02-2000
(TR-7400) Making meter lamp in TR-7400A last longer

Author: Trio-Kenwood Communication, inc.

Service bulletin no. 34 (15-5-1979)

The life of the meter Lamp in the TR-7400A may be extended by inserting a 22ohm 1/4W resistor in series it. This resistor may be conveniently mounted on the circuit board that holds the lamp by cutting foil path on one side of the lamp and soldering the resistor across the break in the foil path. A drawing of the circuit board with the resistor added is shown below.

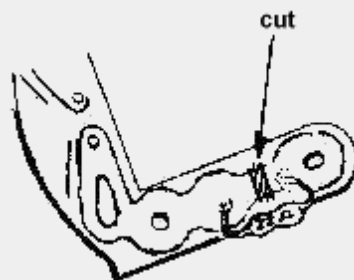

19-07-1998
(TR-751) TR851E & TR751E with 9600

Hello, Carl!

I have read one of your messages - you have asked for modifications of TR851.

I am also using TR851E (European Version) and TR751E with my 9600 BD- Modem (G3RUH) with the following modifications:

When you remove the bottom panel, you can see immediately all you need to do the modifications:

- Varicap Diode D21
- IF-Filter CF1
- Discriminator IC2

View from bottom side:

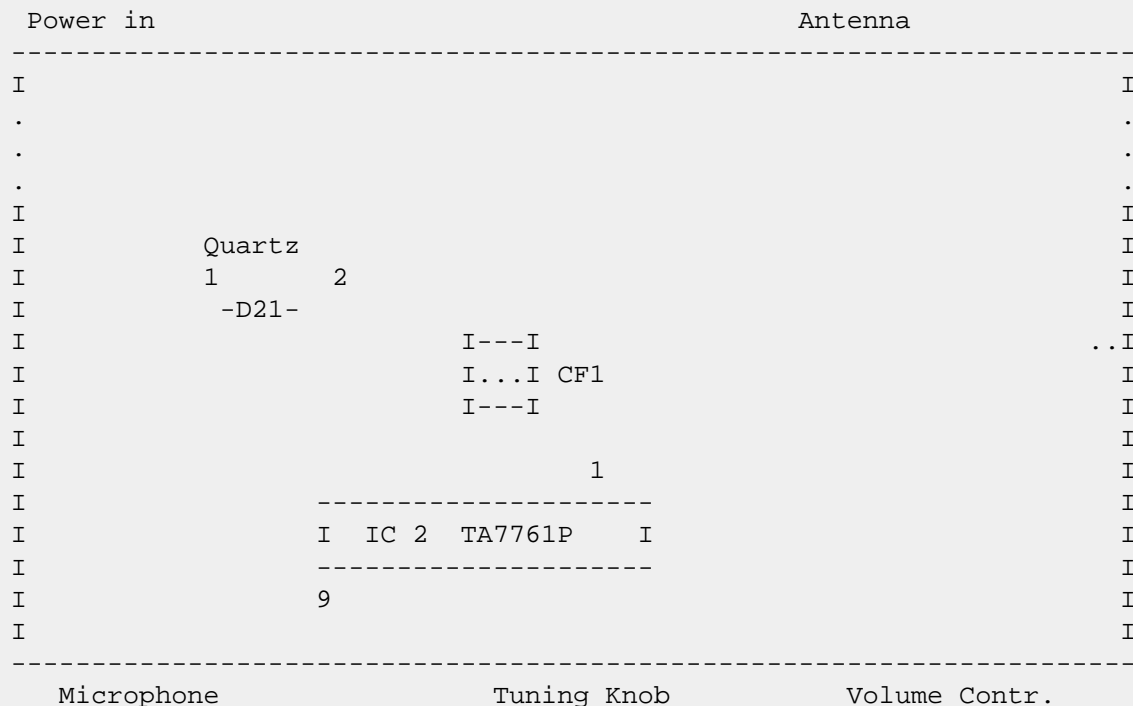

IC 2 Discriminator

PIN 9 of IC 2 -----> - Capacitor (100nF) -----> -RX-Audio G3RUH-Modem

D21 Varicap-Diode

Pin 2 (has no ring!!) -----> TX-Audio G3RUH-Modem

IF-Filter (G3RUH recommends changing)

Replace CF1 (55 F) with CFM 455 D

I thought that the replacement of CF1 was too difficult for me. So I have asked a good friend to remove the PCB and to replace the filter...no problem, he said, and for him it was really not a problem.

The other modifications I have done by myself .

I have done the same modification to TR751 without changing the IF-Filter, because I only need TR 751 for uplink.

The components on the PC Board are close one to another, but I think that other TX/RX are more problematicly to modify.

This modification is read 1258 times.

[top of page](#)

02-07-2000

(TR-751) TR-751A out of band mod

1. Disconnect the power and ant.
2. Remove case.
3. Locate the control unit.
4. Cut diode D1. located to left of 1C3.
5. Reassemble the radio.
6. Reset cpu.

This modification is read 1511 times.

[top of page](#)

02-07-2000

(TR-751) Kenwood TR-751 mod sheet

Author: PE-1MXV - Peter de Blecourt - pe1mxv@ardfnl.demon.nl MODIFICATION.NET

Look in schematic plan for location of diodes D3, D4, D5, D6, D7.
They are located at printed circuit in rightcorner behind frontpanel.

D3	D4	D5	D6	D7	Omschrijving
0	1	1	1	1	European version
x	x	x	x	0	Step 5kHz / 10 kHz (FM)
x	x	x	x	1	Step 12.5kHz / 5 kHz (FM)
x	x	0	0	x	Tone button : Call Channel. Funcnt and Voice buttons : select CTCSS
x	x	0	1	x	Toon button : When PTT pressed 1,5s 1750 Hz tone (UK version). Funcnt and Voice buttons : no funktion.
x	x	1	0	x	Tone button : Call Channel. Funcnt and Voice buttons : select CTCSS
x	x	1	1	x	Toon button : When pressed 1750 Hz tone. TX transmitting !!! Funcnt and Voice buttons : no funktion.
0	0	x	x	x	Rx / Tx 144 - 146 MHz

0	1	x	x	x	Rx / Tx 144 - 146 MHz
1	0	x	x	x	Rx / Tx 144 - 148 MHz
1	1	x	x	x	Rx / Tx 142 - 149 MHz
0	0	0	0	1	TR-751 met CTCSS Step 12.5kHz / 5 kHz (FM) Tone button : call channel. Funct and Voice buttons : select CTCSS Rx / Tx 144 - 146 MHz
				0	No diode present
				1	Diode present

This modification is read 1546 times.

[top of page](#)

19-07-1998

(TR-7600) Alternator Whine, TR-7600/7625

Author: Trio-Kenwood Communication, inc.

Service bulletin no. 39 (9-7-1979)

In some mobile installations, alternator whine may be heard during transmit. External B+ filtering does not have sufficient effect.

In some instances, using the cigarette lighter will cause this problem. Running off the fuse block, and even directly from the battery may still not eliminate the noise.

First, check power line routing in the engine compartment. It should be kept clear of all secondary HV harness wiring, and clear of the alternator, regulator, and ignition primary circuits. Careful routing should reduce or eliminate noise coming in through the power line.

Check for clean ground connections at the antenna and radio.
Check for clean and tight battery connections.

If all of these measures fail, replace L22 on the VCO unit X50-1580-10 from the original green coil, to either an orange or black coil. No adjustments should be necessary.

Old part number L40-1021-03 1mH
New part number L40-1021-43 1mH

Please notate your Service Manual.

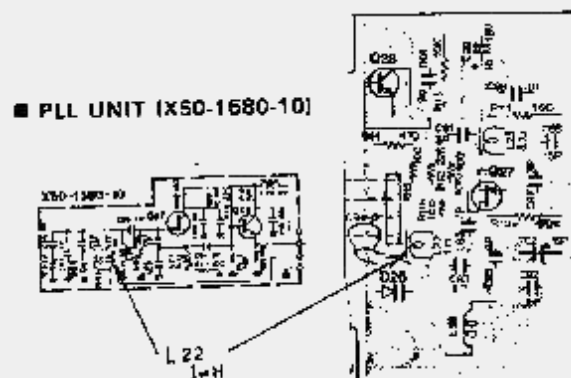

This modification is read 439 times.

[top of page](#)

20-02-2000

(TR-7600) Correcting Frequency Difference Between RM-76 and TR-7600/TR-7625

Author: Trio-Kenwood Communication, inc.

Service bulletin no. 33 (19-3-1979)

The RM-76 will be about 500Hz higher in frequency than the TR-7600/TR-7625. This will not present any problem most of the time. Out specified tolerance is $\pm 750\text{Hz}$.

The operating frequency may be out of the receiver input of a repeater if the transceiver is turned slightly high however.

The frequency difference may be corrected by adding additional diodes in series with both the 02 and 52 lines in the RM-76. This is shown in the figure below.

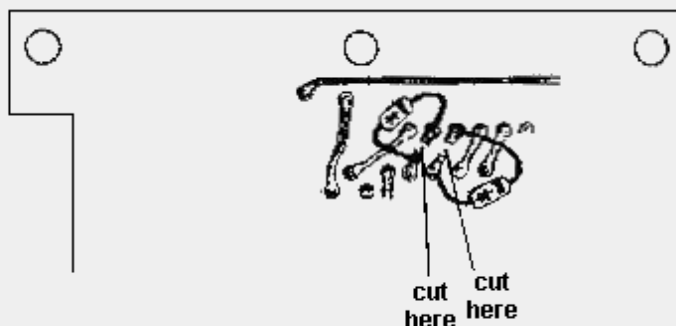

The foil paths from the connector to diodes D18 and D19 are cut and the new diodes soldered on the foil side of the board. The cathode and of the diodes is soldered to the connector side. We recommend using either 1S2076 or 1S1555 diodes.

This modification is read 440 times.

[top of page](#)

20-02-2000

(TR-7600) TR-7600/7625 Audio tone on TX

Author: Trio-Kenwood Communication, inc.

Service bulletin no. 45 (10-8-1979)

Some TR-7600/7625 users report a 0w-background tone during TX, especially noticeable at full quieting by the receiving station.

On the PLL unit X50-1580-00, changes:

- L18 from 22uH to 33uH
- C61 from 22pF to 33pF
- C60 from 22pF to 10pF
- C42 from 22pF to 39pF, or bridge 18pF across foil side & leave original C42 in place. No adjustment necessary.

New Part L18 33uH L40-3301-03

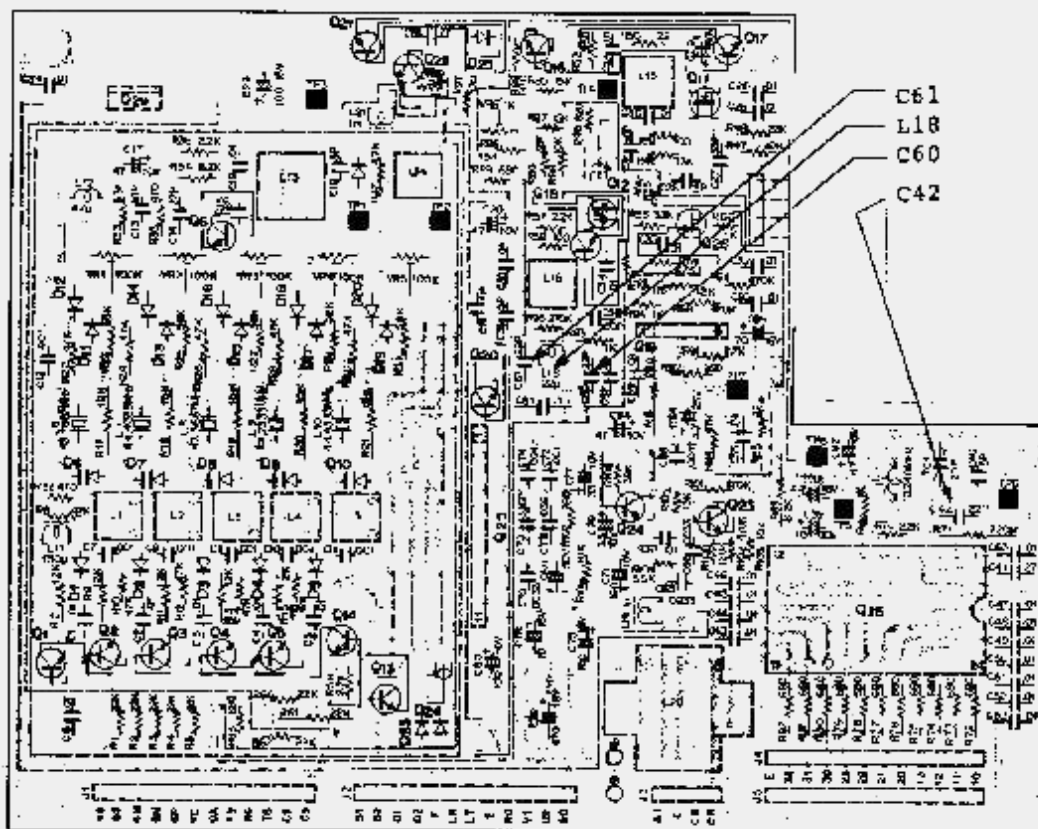

This modification is read 437 times.

[top of page](#)

20-02-2000

(TR-7600) TR-7600/7625 Optional ceramic filter

Author: Trio-Kenwood Communication, inc.

Service Bulletin no. 50 (9-8-1979)

Adjacent channel rejection may be improved by changing one capacitor & installing an optional narrow ceramic filter. On the TX RX unit X44-1320-10, change;

- L41, CFT-455 F2 to CFL-455 F
- C101, from 470pF to .001uF

Old Part L41 L72-0309-05 CFT-455 F2

New Part L41 L72-0306-05 CFL-455 F

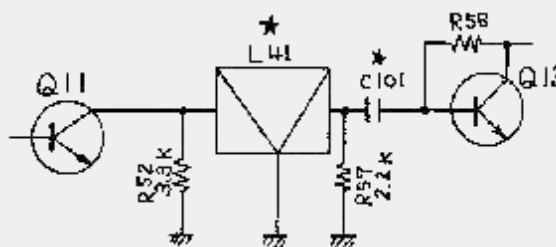

This modification is read 427 times.

[top of page](#)

18-03-2000

(TR-7600) TR-7600, TR-7625 Battery Memory Backup

Author: Trio-Kenwood Communication, inc.

Service Bulletin no. 806 (7-2-1980)

Memory in either radio may be retained by installing a battery inside the unit. This feature would be useful when transporting the radio base to mobile, or when operating base. The AC supply can be shut off while retaining the single memory.

Obtain and install a small 6V DC battery, appropriately secured and insulated, inside the radio. Wire as illustrated through a diode. Current drain will be approximately 0.5 mA with the mail supply OFF.

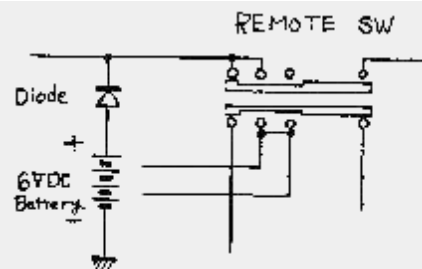

This modification is read 442 times.

[top of page](#)

19-07-1998

(TR-7625) Alternator Whine, TR-7600/7625

Author: Trio-Kenwood Communication, inc.

Service bulletin no. 39 (9-7-1979)

In some mobile installations, alternator whine may be heard during transmit. External B+ filtering does not have sufficient effect.

In some instances, using the cigarette lighter will cause this problem. Running off the fuse block, and even directly from the battery may still not eliminate the noise.

First, check power line routing in the engine compartment. It should be kept clear of all secondary HV harness wiring, and clear of the alternator, regulator, and ignition primary circuits. Careful routing should reduce or eliminate noise coming in through the power line.

Check for clean ground connections at the antenna and radio.
Check for clean and tight battery connections.

If all of these measures fail, replace L22 on the VCO unit X50-1580-10 from the original green coil, to either an orange or black coil. No adjustments should be necessary.

Old part number L40-1021-03 1mH
New part number L40-1021-43 1mH

Please notate your Service Manual.

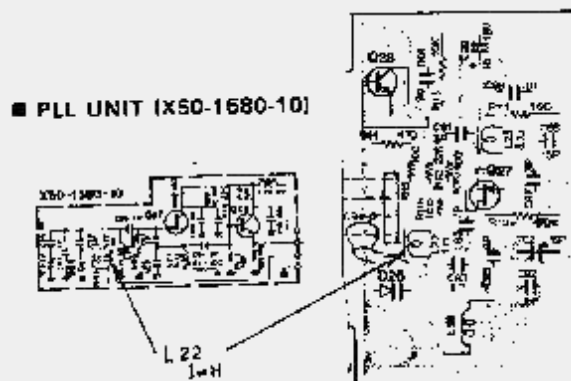

This modification is read 491 times.

[top of page](#)

19-07-1998

(TR-7625) TR-7625 Intermittent TX

Author: Trio-Kenwood Communication, inc.

Service Bulletin no. 804 (7-2-1980)

When servicing a TR-7625 for mechanically intermittent TX, check the heavy WHITE DRB lead at the push-on connector directly in front of relay RL1 on the RX TX unit.

This post may either become separated from the land, or the land may crack from vibration. Resolder the post, plus reinforce the connection with a small piece of solid wire soldered on the foil side of the board.

This modification is read 485 times.

[top of page](#)

20-02-2000

(TR-7625) Correcting Frequency Difference Between RM-76 and TR-7600/TR-7625

Author: Trio-Kenwood Communication, inc.

Service bulletin no. 33 (19-3-1979)

The RM-76 will be about 500Hz higher in frequency than the TR-7600/TR-7625. This will not present any problem most of the time. Out specified tolerance is $\pm 750\text{Hz}$.

The operating frequency may be out of the receiver input of a repeater if the transceiver is turned slightly high however.

The frequency difference may be corrected by adding additional diodes in series with both the 02 and 52 lines in the RM-76. This is shown in the figure below.

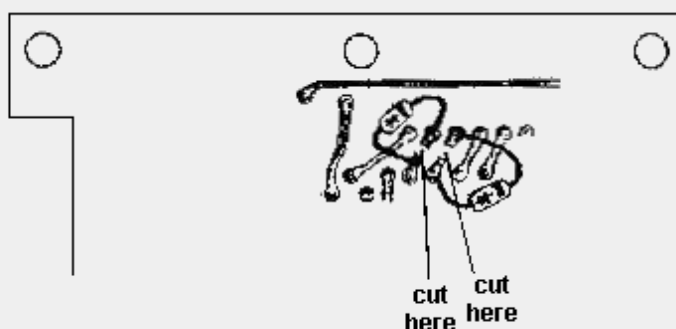

The foil paths from the connector to diodes D18 and D19 are cut and the new diodes soldered on the foil side of the board. The cathode and of the diodes is soldered to the connector side. We recommend using either 1S2076 or 1S1555 diodes.

This modification is read 476 times.

[top of page](#)

20-02-2000

(TR-7625) TR-7600/7625 Audio tone on TX

Author: Trio-Kenwood Communication, inc.

Service bulletin no. 45 (10-8-1979)

Some TR-7600/7625 users report a 0w-background tone during TX, especially noticeable at full quieting by the receiving station.

On the PLL unit X50-1580-00, changes:

- L18 from 22uH to 33uH
- C61 from 22pF to 33pF
- C60 from 22pF to 10pF
- C42 from 22pF to 39pF, or bridge 18pF across foil side & leave original C42 in place. No adjustment necessary.

New Part L18 33uH L40-3301-03

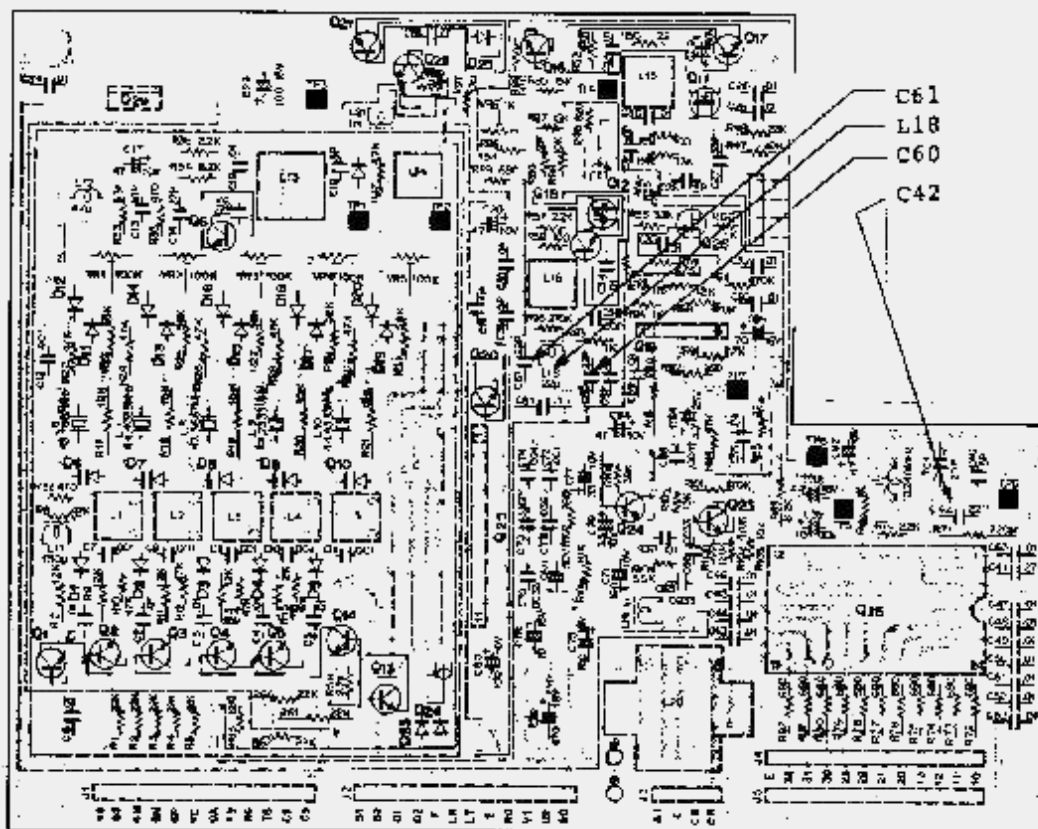

This modification is read 480 times.

[top of page](#)

20-02-2000

(TR-7625) TR-7600/7625 Optional ceramic filter

Author: Trio-Kenwood Communication, inc.

Service Bulletin no. 50 (9-8-1979)

Adjacent channel rejection may be improved by changing one capacitor & installing an optional narrow ceramic filter. On the TX RX unit X44-1320-10, change;

- L41, CFT-455 F2 to CFL-455 F
- C101, from 470pF to .001uF

Old Part L41 L72-0309-05 CFT-455 F2

New Part L41 L72-0306-05 CFL-455 F

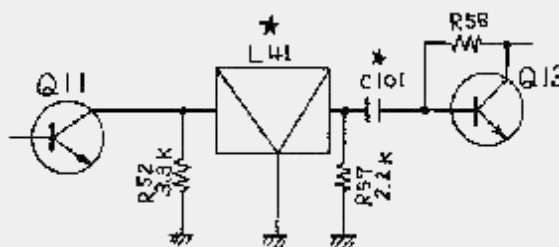

This modification is read 468 times.

[top of page](#)

18-03-2000

(TR-7625) TR-7600, TR-7625 Battery Memory Backup

Author: Trio-Kenwood Communication, inc.

Service Bulletin no. 806 (7-2-1980)

Memory in either radio may be retained by installing a battery inside the unit. This feature would be useful when transporting the radio base to mobile, or when operating base. The AC supply can be shut off while retaining the single memory.

Obtain and install a small 6V DC battery, appropriately secured and insulated, inside the radio. Wire as illustrated through a diode. Current drain will be approximately 0.5 mA with the mail supply OFF.

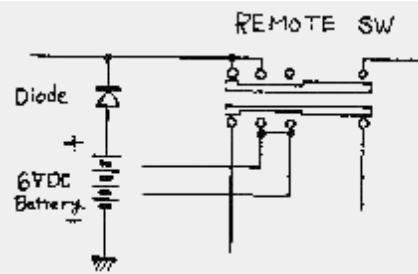

This modification is read 473 times.

[top of page](#)

19-03-2000

(TR-7625) TR-7625 Final module replacement

Author: Trio-Kenwood Communication, inc.

Service Bulletin no. 820

When replacing the output hybrid with a "red dot" unit, an additional 47pF cap must be installed between the M57712H output terminal and the RFO warp post.

Install the M57712H with white silicone heat sink compound. Install a 47pF as shown between the hybrid output and the RFO terminal. Spread L21 as necessary for at least 30W output at approximately 5.5A total current consumption.

Note: Hybrids not having a red Mitsubishi logo do not require the additional cap or adjustment.

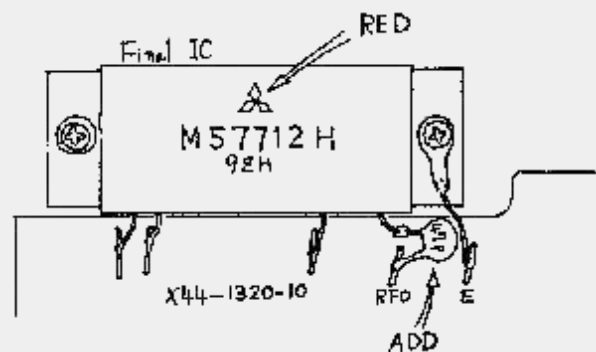

This modification is read 482 times.

[top of page](#)

19-03-2000

(TR-7625) TR-7625 Hybrid amplifier module substitution

Author: Trio-Kenwood Communication, inc.

Service Bulletin no. 826 (30-5-1980)

(Supercedes #820)

Final modules obtained from Trio-Kenwood Communication's Parts Department after 1/5-1980 MUST be installed as outlined. Two versions of the hybrid may be supplied, either marked as an M57712H, or as an M57733. This information applies in either case.

Installations:

1. Remove and delete C49, 22pF
2. Add a ground lug adjacent to the RFI terminal.
3. Add 10pF across the RFI terminal and ground.

Adjustment:

1. Adjust TC2 for maximum output at 146MHz-
2. Adjust VR4 for 5W output at 146MHZ, low power.

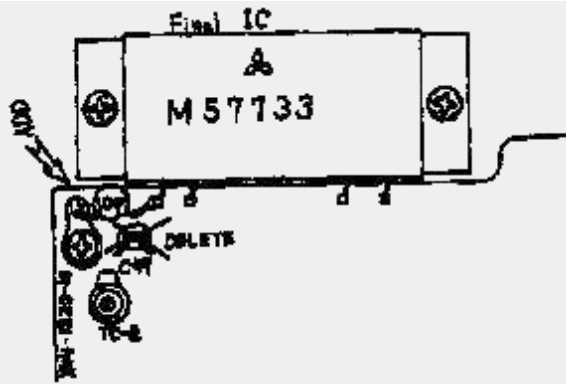

New part: 10pF C45CH1000

This modification is read 483 times.

[top of page](#)

19-07-1998

(TR-7730) TR-7730 Transmitter Freq Response, Voice or DTMF

Author: Trio-Kenwood Communication, inc.

Service Bulletin no. 854 (25-1-1982)

Operator complaints of insufficient lows in transmit, or faulty Autopatch operation traceable to incorrect twist (high to low tone group balance) may be remedied by changing two capacitors at the mic amplifier input.

On the RX/TX unit X44-1450-61, change C78 and C81 from 0.1uf to 1.0uf, 35v tantalum (CS15E1V010M) to increase low frequency transmitter frequency response. Adjust Deviation (VR3) or mic gain (VR2) as necessary.

Installation time for this procedure is 1/2 or less.

This modification is read 304 times.

[top of page](#)

19-07-1998

(TR-7800) TR-7800 Loss of Memory

Author: Trio-Kenwood Communication, inc.

Service Bulletin no. 829 (31-7-1980)

Intermittent loss of memory may be corrected by adding one resistor at the microprocessor on the control unit.

Procedure:

1. Remove bottom cover, 4 screws.
2. From the Control unit X53-1180-xx unplug the rear mounted connectors 8-11.
3. Remove 6 screws from the board.
4. Swing the unit forward.
5. Install a 470K ohm 1/8 watt or larger resistor from connector 11, "UP" pin, to ground. (microprocessor pin 35, PA2 port). Space is limited: Be certain not to create a solder bridge when installing the resistor.
6. Reverse steps 4-1 for reassembly.

This modification is read 611 times.

[top of page](#)

19-07-1998

(TR-7800) TR-7800/TR-9000 Optional Ceramic Filters

FM Adjacent channel rejection in either unit may be improved by installing an optional narrow ceramic filter.

Filter	Part No.	-6db Bandwidth	-70db Bandwidth	Retail
CFK-455F	L72-0304-05	+/- 6 kHz	+/- 12 kHz	\$ 33.50
CFK-455G	(CFK-455G)*	+/- 4 kHz	+/- 10 kHz	\$ 33.50

* Not original part. No computer part number.

Location:

TR-7800, RX unit X55-1270-10 part, L10

TR-9000, RX unit X55-1260-11 part, CF1

To install, desolder the original filter and clear the second set of holes for the optional filter. Solder the new filter in place. Be sure all pins are actually soldered, and that there are no solder bridges between pins or across the printed circuit board. Clip the pins flush to the board, and reinstall the circuit board.

Note: Squelch operation will vary from unit to unit with an optional narrow filter. Tighter coupling from the detector to the squelch circuit may be tried to restore "original feel".

This modification is read 578 times.

[top of page](#)

19-03-2000

(TR-7800) TR-7800 Tone pad conversion for 4th column function

Author: Trio-Kenwood Communication, inc.

Service Bulletin no. 828 (3-6-1980)

Users who desire ABCD control functions may be accommodate by an alteration to the Control unit and to the REV switch. This switch will then perform dual functions.

1. Remove top and bottom covers, 4 screws each.
2. To free the front panel remove 4 screws securing the front panel bracket to the side frame.
3. Unplug 5 multiconnectors from the Control unit along the front and left edges of the board.
4. Remove 6 screws from the Control unit and swing the board over.
5. Remove and save R51 22 Kohm located between IC's Q19 and Q28. (Q28 pin 5).
6. Resolder this 22 Kohm resistor to Q28 pin 5, and solder another 22 Kohm resistor to Q28 pin 9. Using a short piece of hookup wire, extend these connections t the REV switch as shown.
7. Connect a line from the center switch contact to the original feed point of R51, which is the B3 line.
8. To reassemble, reverse steps 4 through 1.

To operate the ABCD column, hold the REV switch IN and key the 3, 6, 9, or # keys. Normal 3rd column tones are supplied when the REV switch is not depressed. The receive REV function is not altered by this change.

Note: This switch is a DPDT and many have both sets of contacts bridged. Free one set of contacts for this new function.

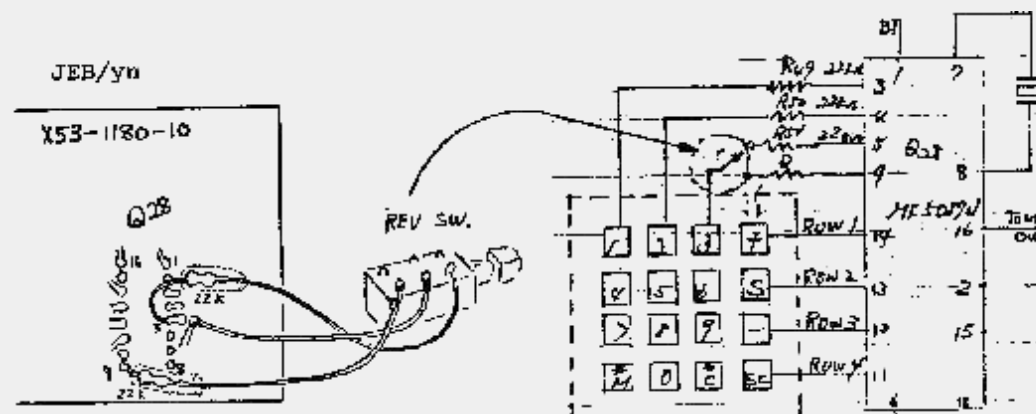

This modification is read 580 times.

[top of page](#)

02-04-2000

(TR-7800) TR-7800 Pulse noise

Author: Trio-Kenwood Communication, inc.

Service Bulletin no. 834 (6-1-1981)

Low level Pulse Noise reported in high power TX, or as a buzz from the speaker during TX, may be reduced or eliminated by the following steps.

1. If not already present, install a shield (F11-0781-04) and two 1000pF capacitors (C52-1710-26) at the final amplifier module M57733 as shown.

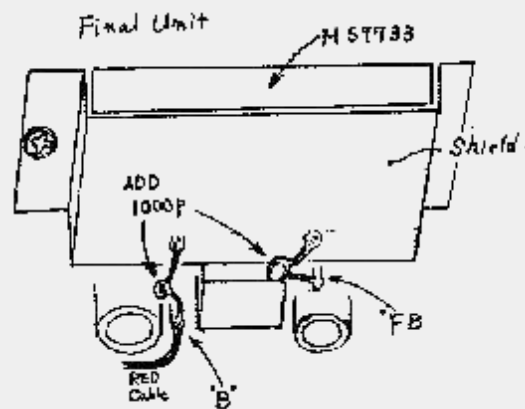

2. On the RX unit X55-1270-10 add three additional 1000pF caps (c52-1710-26) and one additional 470pF cap (C52-1747-16) as shown.

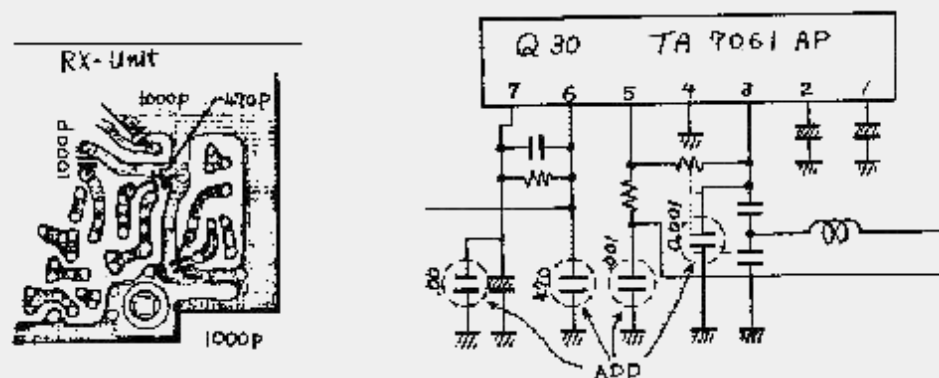

Installattion time for this precedure is approximately ½ hour.

This modification is read 571 times.

[top of page](#)

02-04-2000

(TR-7800) TR-7800 Optional continuous charge for internal batteries

Author: Trio-Kenwood Communication, inc.

Service Bulletin no. 836 (19-11-1980)

The internal batteries for memory back-up charge only when the radio is on. If the radio is used less than 2 hours a day, the internal batteries may not charge sufficiently to retain memory if the main power is diconnected. This optional chanhe may be made to continuously charge the internal batteris from the main power source, whether the radio is on or off.

1. On the RX unit X55-1270-10, change R94 from 56 ohm to 120 ohm, ½W.
2. Cut the foil at the input to Q27 and connect via a 3/4" lead to the BB terminal on connector 1.
3. Battery charge current will be 15mA nominal.

Notes:

1. The radio should be connected directly to the vehicle battery and not through the ignition switch.
2. Turn the radio off before connecting or disconnecting the power cable.

For early units:

3. Before closing the case, check alearance from the back of the battery case to the shassis. If very close, add suitable insulation

between the battery case and chassis.

4. Check for the presence of a 470 kohm 1/8W resistor which should be located on the bottom of the Control unit X53-1180-xx, Connector 11, UP pin. Add if not already installed (and see Service Bulletin #829).

This modification is read 591 times.

[top of page](#)

08-04-2000

(TR-7800) Memory Channel 7 Indicator Erratic

Author: Trio-Kenwood Communication, inc.

Service Bulletin no. 860 (14-4-1982)

When Memory Channel 7 is selected, the LED may fail to indicate the number 7, although frequency is correctly recalled and all other operations are normal. Cause is incorrect voltage level at Q16 & Q17, and is related to individual differences between these IC's. Correction is by changing one resistor value on the control unit.

On the control unit X53-1130-xx, replace R38 from 3.9 Kohm to a 1.8 Kohm resistor (RD14CB2E182J). No adjustments are required.

This change should be perform only as necessary, and applies to units before serial number 205xxxx.

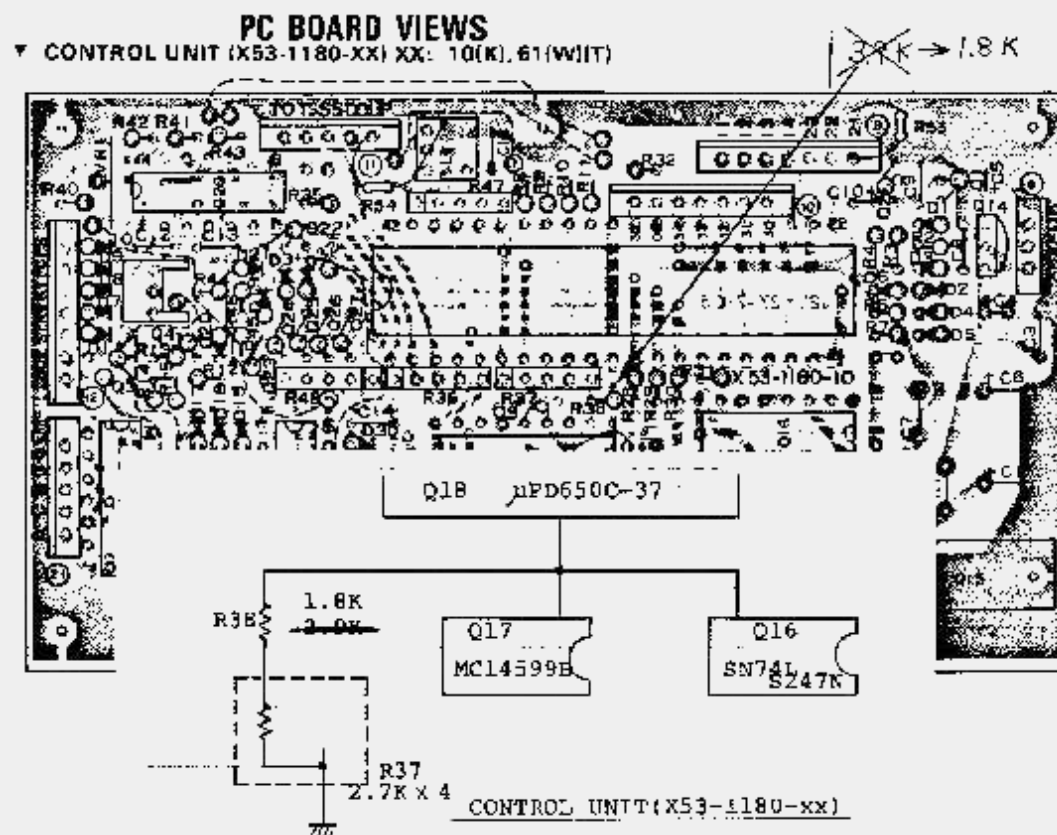

Installation time for this procedure is ½ hour or less.

This modification is read 572 times.

[top of page](#)

08-04-2000

(TR-7800) TR-7800, TR-7850 Memory Improvements

Author: Trio-Kenwood Communication, inc.

Service Bulletin no. 861 (5-4-1982)

TR-7800 & TR-7850 memory retention may be improved by the following changes on the control and RX units.

Control unit X53-1180-xx

1. If not already present, add a 470 Kohm ½W resistor (RD14BB2B474J) (R54) on the foil side of the board from connector 11 UP line to ground. (Unite before serial number 1119391).
2. If not already present, add a 470 Kohm ½W resistor (RD14BB2B474J) (R55) on the foil side of the board connector 11 DOWN line to ground. (Unite before serial number 1119391).
3. Hard-wire the two via holes (through hole without components leads installed) along the foil trace between Q18 pin 1 and L1.

4. Change D1 from an ZX-060 (6V, 5%) to a WZ-040 (VII-4102-40) (4V, 10%) Zener.
5. Check D3 for leakage, which would load the MB line voltage below its normal 5.2 V DC setting.

RX unit X55-1270-xx

1. TR-7800: Change R94 from 56 ohm to 150 ohm ½W (RD14CB2E151J).
2. TR-7850: Change R94 from 100 ohm to 150 ohm ½W (RD14CB2E151J).
3. Cut the foil at the input to Q27, and connect Q27 input to the BB terminal. Connector 1 for constant battery charge at Power switch Off, and floating battery charge when using a TK-1 or BC-1 charger unit for memory back-up in base station operation.
4. Check D18 for leakage, loading the MB line.

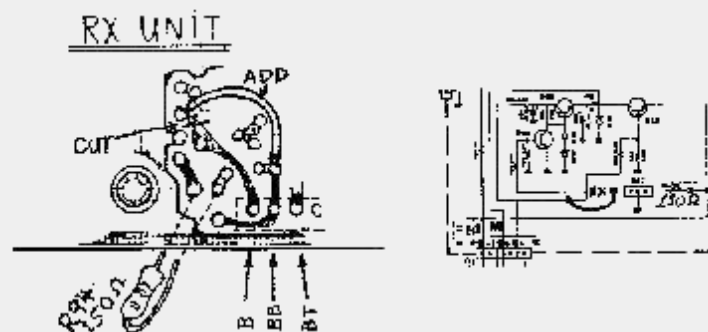

Note:

1. With 13.8V DC applied to the radio, and the power switch OFF, adjust VR2 on the RX unit for 5.2V DC at connector 1, MB terminal.
2. We recommend using either Sanyo or GE NiCad Batteries. We suggest not using Radio Shack or Eveready batteries in these radios.
3. If memory loss persists after all changes and checks suspect control unit Q18 is defective.

This modification is read 606 times.

[top of page](#)

19-07-1998

(TR-7850) TR-7850 RF LED Meter

Author: Trio-Kenwood Communication, inc.

Service Bulletin no. 846 (29-7-1981)

The RF LED meter may show reduced output after continuous transmission, while output actually remains constant. Changing components on the final unit will correct this problem. This change applies to units before serial number 201XXXX.

Procedure:

1. Remove the top cover (four screws), and unplug the speaker.
2. Remove the bottom cover (four screws).
3. Remove four screws holding the heatsink and swing the sink down.
4. Without changing coil spacing, desolder L6 which connects from the ANT pad on the final unit to the PL-259, at the final unit.
5. Remove five screws holding the final unit pcb X45-1180-10, one screw holding Q6 2SD880, and two screws holding the final hybrid module Q1, M57726.
6. Change the following parts:
 - C15 1pf to 2pf (CC45CH1H020C)
 - D3 1N60 to 1S1587 (V11-0370-05)
 - R8 820 ohm to 1.2K (RD14CD2E122J)
7. Insure adequate thermal compound on Q1 and Q6, and that the mica washer is correctly positioned under Q6. Reverse steps 5 and 4 to partially assemble.
8. Cable-up power and a dummy load. Readjust VR1 on the final unit at 147.000 MHz, high power setting for 5 LED's ON. Switch to low power and verify 3 LEDs ON.
9. Remove power from the unit and complete reassembly by reversing steps 3, 2, and 1.

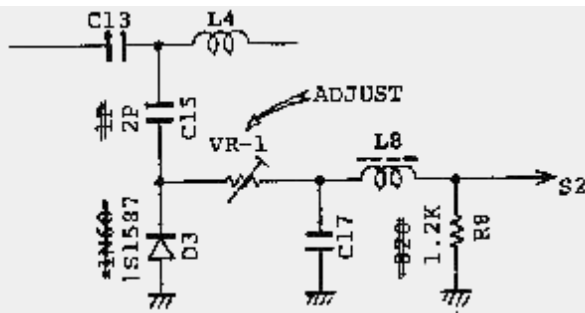

Note: installation time for this procedure is 1/2 hour or less.

This modification is read 544 times.

[top of page](#)

08-04-2000

(TR-7850) Memory Channel 7 Indicator Erratic

Author: Trio-Kenwood Communication, inc.

Service Bulletin no. 860 (14-4-1982)

When Memory Channel 7 is selected, the LED may fail to indicate the number 7, although frequency is correctly recalled and all other operations are normal. Cause is incorrect voltage level at Q16 & Q17, and is related to individual differences between these IC's. Correction is by changing one resistor value on the control unit.

On the control unit X53-1130-xx, replace R38 from 3.9 Kohm to a 1.8 Kohm resistor (RD14CB2E182J). No adjustments are required.

This change should be perform only as necessary, and applies to units before serial number 205xxxx.

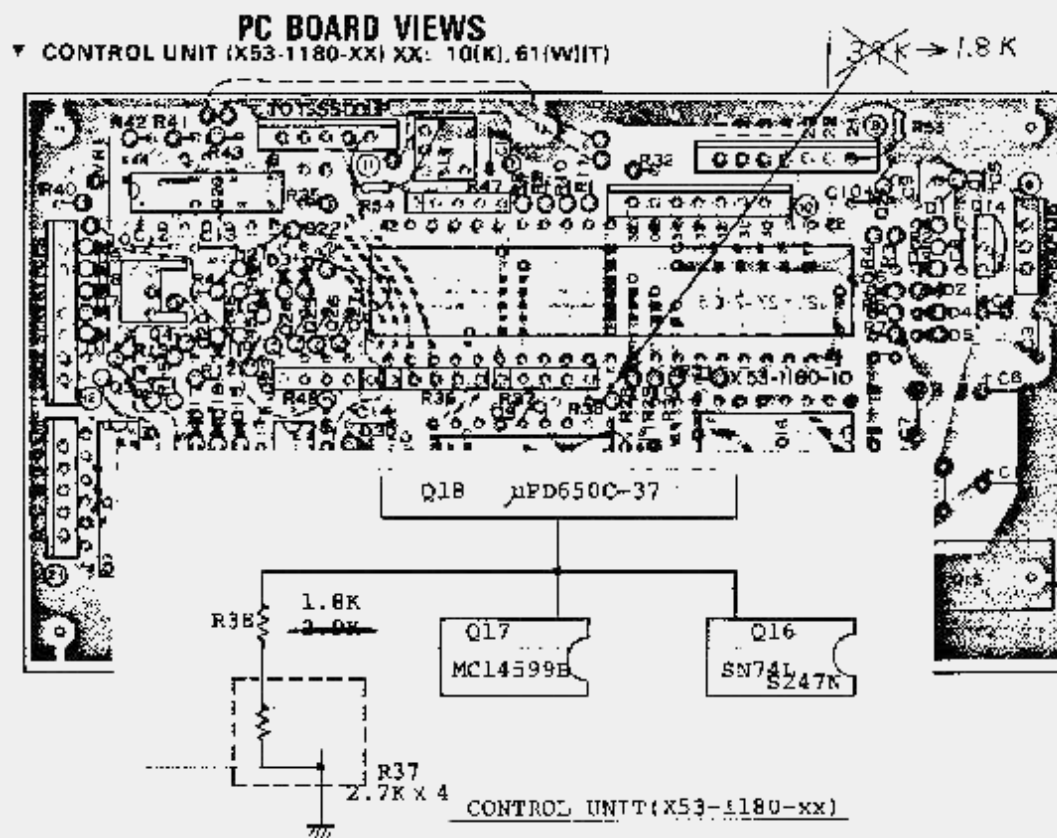

Installation time for this procedure is ½ hour or less.

This modification is read 498 times.

[top of page](#)

08-04-2000

(TR-7850) TR-7800, TR-7850 Memory Improvements

TR-7800 & TR-7850 memory retention may be improved by the following changes on the control and RX units.

Control unit X53-1180-xx

1. If not already present, add a 470 Kohm ½W resistor (RD14BB2B474J) (R54) on the foil side of the board from connector 11 UP line to ground. (Unite before serial number 1119391).
2. If not already present, add a 470 Kohm ½W resistor (RD14BB2B474J) (R55) on the foil side of the board connector 11 DOWN line to ground. (Unite before serial number 1119391).
3. Hard-wire the two via holes (through hole without components leads installed) along the foil trace between Q18 pin 1 and L1.
4. Change D1 from an ZX-060 (6V, 5%) to a WZ-040 (VII-4102-40) (4V, 10%) Zener.
5. Check D3 for leakage, which would load the MB line voltage below it normal 5.2 V DC setting.

RX unit X55-1270-xx

1. TR-7800: Change R94 from 56 ohm to 150 ohm ½W (RD14CB2E151J).
2. TR-7850: Change R94 from 100 ohm to 150 ohm ½W (RD14CB2E151J).
3. Cut the foil at the input to Q27, and connect Q27 input to the BB terminal. Connector 1 for constant battery charge at Power switch Off, and floating battery charge when using a TK-1 or BC-1 charger unit for memory back-up in base station operation.
4. Check D18 for leakage, loading the MB line.

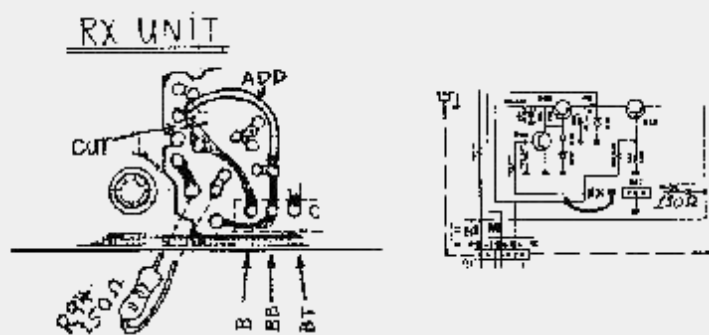

Note:

1. With 13.8V DC applied to the radio, and the power switch OFF, adjust VR2 on the RX unit for 5.2V DC at connector 1, MB terminal.
2. We recommend using either Sanyo or GE NiCad Batteries. We suggest not using Radio Shack or Eveready batteries in these radios.
3. If memory loss persists after all changes and checks suspect control unit Q18 is defective.

This modification is read 532 times.

[top of page](#)

19-07-1998

(TR-7900) TR-7800/TR-9000 Optional Ceramic Filters

10-10-80

FM Adjacent channel rejection in either unit may be improved by installing an optional narrow ceramic filter.

Filter	Part No.	-6db Bandwidth	-70db Bandwidth	Retail
CFK-455F	L72-0304-05	+/- 6 kHz	+/- 12 kHz	\$ 33.50
CFK-455G	(CFK-455G)*	+/- 4 kHz	+/- 10 kHz	\$ 33.50

* Not original part. No computer part number.

Location:

TR-7800, RX unit X55-1270-10 part, L10

TR-9000, RX unit X55-1260-11 part, CF1

To install, desolder the original filter and clear the second set of holes for the optional filter. Solder the new filter in place. Be sure all pins are actually soldered, and that there are no solder bridges between pins or across the printed circuit board. Clip the pins flush to the board, and reinstall the circuit board.

Note: Squelch operation will vary from unit to unit with an optional narrow filter. Tighter coupling from the detector to the squelch circuit may be tried to restore "original feel".

19-07-1998**(TR-7930) TR-7930 info**

Insert the spread terminal "8-m" into the top of plug "j-18" so it fits around the top of terminal "ap". This is a fairly tight fit, so use care not to bend the terminals by using too much pressure.

About half of terminal "8-m" will stick up above the top of terminal "ap". The lower part will be firmly sleeved around terminal "ap" inside the plug.

Dress the wire around the left side of the board.

Replace speaker plug and install top cover.

Plug tnc cable with ptt/audio in/audio out/ground connectons into mic connector and it's ready to go on packet/rtty.

No soldering is required and unit can be returned to original state at any time if necessary.

19-07-1998**(TR-7930) TR-7930/7950 transceiver for packet/rtty operation**

Circuit modification for Kenwood TR7930/7950 transceiver
for packet/rtty operation
by: WA4IXN

This modification provides controlable audio output to pin 5 of the mic connector for single plug packet/ rtty operation.

Remove top cover of transceiver and carefully disconnect speaker lead plug from "rx unit" board.

Locate plugs "j-13" on the right front of the "rx unit" board and "j-18" on the left rear side of the board.

Notice which wire goes to pin "8-m" on "j-13" and to pin #5 on the mic connector.

Remove plug "j-13" from the board and locate the spring tab on the side of the plug that holds the "8-m" connector in place.

Using a small awl or pointed tool, press the tab down and carefully pull the "8-m" connector from the plug.

Work the wire from the harness so it will reach back along the left side of the board to plug "j-18".

Using the awl or small pointed tool, carefully spread the "8-m" connector a slight amount so it can be fitted Like a sleeve over another connector of the same size.

locate terminal "ap" on plug "j-18".

Insert the spread terminal "8-m" into the top of plug "j-18" so it fits around the top of terminal "ap". This is a fairly tight fit, so use care not to bend the terminals by using too much pressure.

About half of terminal "8-m" will stick up above the top of terminal "ap". The lower part will be firmly sleeved around terminal "ap" inside the plug.

Dress the wire around the left side of the board.

Replace speaker plug and install top cover.

plug tnc cable with ptt/audio in/audio out/ground connectons into mic connector and it's ready to go on packet/rtty.

No soldering is required and unit can be returned to original state at any time if necessary.

19-07-1998**(TR-7930) TR-7950/30 RX Interference**

4-8-83

Some users have reported FM Broadcast or TV video carrier interference to the receiver. Normally the TR-7950/30 has excellent two signal intermodulation characteristics. For a reported case of Broadcast or TV IMD the following modification may reduce or eliminate the interference.

Parts Required**Qty Description**

1 MI-308 Diode

Procedure

1. REmove the top and bottom covers.
2. Remove the 4 screws that secure the heat sink assembly to the rear of the set. Gently pull the heat sink assembly to the rear, to allow access to the final unit X54-1270-1-,11.

3. Remove the 5 screws securing the PC board to the heat sink. Remove the 2 screws securing the final module (M57733/M57726) and remove the screw that secures Q2 to the heat sink. Carefully desolder L9 from the antenna connector. (Dont change the spacing of the coils!!!)
4. Gently fold the assembly over to allow access to the foils side of the final assembly and remove D2, and replace it with the MI-308 diode.
5. Reverse steps 1-3 to reassemble. Reconnect L9 but don't change the spacing of the coils. Use heat sink compound when replacing the final module.

This is an optional change and may not be performed in warranty.

This modification is read 455 times.

[top of page](#)

09-04-2000

(TR-7930) TR-7850/30 RX interference

Author: Trio-Kenwood Communication, inc.

Service Bulletin no. 870 (8-4-1983)

Some users have reported FM broadcast or TV video carrier interference to the receiver. Normally the TR-7850/30 has excellent two signal intermodulation characteristics. For a reported case of broadcast or TV IMD the following modification may reduce or eliminate the interference.

Parts required

Qty	Description
1	M1-308 Diode

Procedure

1. Remove the top and bottom covers.
2. Remove the 4 screws that secure the heat sink assembly to the rear of the set. Gently pull the heat sink assembly to the rear, to allow access to the final unit (X54-1270-10,11).
3. Remove the 5 screws securing the PC board to the heat sink. Remove the 2 screws securing the final module (M5733/M57726) and remove the screw that secures Q2 to the heat sink. Carefully desolder L9 from the antenna connector.
4. Gently fold the assembly over to allow access to the foil side of the final assembly and remove D2, (figure 1), and replace it with the MT-308.
5. Reverse step 1 - 3 to reassemble. See figure 2 for proper connection of L9. Use heat sink compound when replacing the final module.

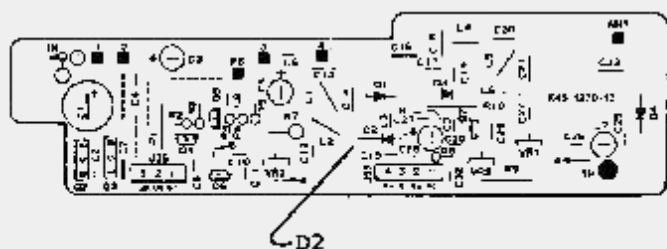

Fig. 1



Fig. 2

Note: This is an optional change and may not be performed in-warranty.

This modification is read 464 times.

[top of page](#)

17-02-2001

(TR-7930) Kenwood TR-7930 Udvidet TX/RX

Author: OZ3AEV Jesper - rc-home@worldonline.dk MODIFICATION.NET

1. Pil bunden af radioen tag fronten mod dig selv.
2. Find den store ic der hedder d7508c 017, den sider i midten af radioen.
3. I venstre side side af den store IC sider 2 dioder klip D16.
4. Samel radioen og reset den.

Nu er der TX - RX fra 142MHz til 149MHz.

Hvis man samtidig klipper diode D17 køre den det amerikanske repeater step.

73
OZ3AEV Jesper.

This modification is read 464 times.

[top of page](#)

19-07-1998

(TR-7950) TR-7950 PA module mod

Just found a Kenwood screwup on the tr-7950. On the power-output board where the PA module is connected is a 470 uf Cap designated C 1. The silkscreen on the board shows the + terminal going to gnd.

The original cap that was factory installed was installed with the positive lead going to the + on the board. This is obviously wrong as the Gnd Foil is the minus lead not the + lead. The cap had swollen up and burst due to incorrect installation. Almost blew another cap till I verified that the MINUS goes to the foil, not the way its marked on the PC board.

If you have a 7950 or 7930 you would do well to pull off the back and inspect the Cap installed at C1. Its the only large filter cap on this board so its easy to locate. If the case looks bulged, better get another cap and install it correctly. 73, N5WX @ N5WX.OK

This modification is read 629 times.

[top of page](#)

19-07-1998

(TR-7950) TR-7930/7950 transceiver for packet/rtty operation

Circuit modification for Kenwood TR7930/7950 transceiver
for packet/rtty operation
by: WA4IXN

This modification provides controlable audio output to pin 5 of the mic connector for single plug packet/ rtty operation.

Remove top cover of transceiver and carefully disconnect speaker lead plug from "rx unit" board.

Locate plugs "j-13" on the right front of the "rx unit" board and "j-18" on the left rear side of the board.

Notice which wire goes to pin "8-m" on "j-13" and to pin #5 on the mic connector.

Remove plug "j-13" from the board and locate the spring tab on the side of the plug that holds the "8-m" connector in place.

Using a small awl or pointed tool, press the tab down and carefully pull the "8-m" connector from the plug.

Work the wire from the harness so it will reach back along the left side of the board to plug "j-18".

Using the awl or small pointed tool, carefully spread the "8-m" connector a slight amount so it can be fitted Like a sleeve over another connector of the same size.

locate terminal "ap" on plug "j-18".

Insert the spread terminal "8-m" into the top of plug "j-18" so it fits around the top of terminal "ap". This is a fairly tight fit, so use care not to bend the terminals by using too much pressure.

About half of terminal "8-m" will stick up above the top of terminal "ap". The lower part will be firmly sleeved around terminal "ap" inside the plug.

Dress the wire around the left side of the board.

Replace speaker plug and install top cover.

plug tnc cable with ptt/audio in/audio out/ground connectons into mic connector and it's ready to go on packet/rtty.

No soldering is required and unit can be returned to original state at any time if necessary.

This modification is read 585 times.

[top of page](#)

19-07-1998

(TR-7950) TR-7950 screwup on the power-output

Just found a Kenwood screwup on the tr-7950. On the power-output board where the PA module is connected is a 470 uf Cap designated C 1. The silkscreen on the board shows the + terminal going to gnd.

The original cap that was factory installed was installed with the positive lead going to the + on the board. This is obviously wrong as the Gnd Foil is the minus lead not the + lead. The cap had swollen up and burst due to incorrect installation. Almost blew another cap till I verified that the MINUS goes to the foil, not the way its marked on the PC board.

If you have a 7950 or 7930 you would do well to pull off the back and inspect the Cap installed at C1. Its the only large filter cap on this board so its easy to locate. If the case looks bulged, better get another cap and install it correctly. 73, N5WX @ N5WX.OK

This modification is read 609 times.

[top of page](#)

19-07-1998

(TR-7950) TR-7950/30 RX Interference

4-8-83

Some users have reported FM Broadcast or TV video carrier interference to the receiver. Normally the TR-7950/30 has excellent two signal intermodulation characteristics. For a reported case of Broadcast or TV IMD the following modification may reduce or eliminate the interference.

Parts Required

Qty Description

1 MI-308 Diode

Procedure

1. Remove the top and bottom covers.
2. Remove the 4 screws that secure the heat sink assembly to the rear of the set. Gently pull the heat sink assembly to the rear, to allow access to the final unit X54-1270-1,11.
3. Remove the 5 screws securing the PC board to the heat sink. Remove the 2 screws securing the final module (M57733/M57726) and remove the screw that secures Q2 to the heat sink. Carefully desolder L9 from the antenna connector. (Don't change the spacing of the coils!!!)
4. Gently fold the assembly over to allow access to the foils side of the final assembly and remove D2, and replace it with the MI-308 diode.
5. Reverse steps 1-3 to reassemble. Reconnect L9 but don't change the spacing of the coils. Use heat sink compound when replacing the final module.

This is an optional change and may not be performed in warranty.

This modification is read 584 times.

[top of page](#)

09-04-2000

(TR-7950) TR-7850/30 RX interference

Author: Trio-Kenwood Communication, inc.

Service Bulletin no. 870 (8-4-1983)

Some users have reported FM broadcast or TV video carrier interference to the receiver. Normally the TR-7850/30 has excellent two signal intermodulation characteristics. For a reported case of broadcast or TV IMD the following modification may reduce or eliminate the interference.

Parts required

Qty	Description
1	M1-308 Diode

Procedure

1. Remove the top and bottom covers.
2. Remove the 4 screws that secure the heat sink assembly to the rear of the set. Gently pull the heat sink assembly to the rear, to allow access to the final unit (X54-1270-10,11).
3. Remove the 5 screws securing the PC board to the heat sink. Remove the 2 screws securing the final module (M5733/M57726) and remove the screw that secures Q2 to the heat sink. Carefully desolder L9 from the antenna connector.
4. Gently fold the assembly over to allow access to the foil side of the final assembly and remove D2, (figure 1), and replace it with the MT-308.
5. Reverse step 1 - 3 to reassemble. See figure 2 for proper connection of L9. Use heat sink compound when replacing the final module.

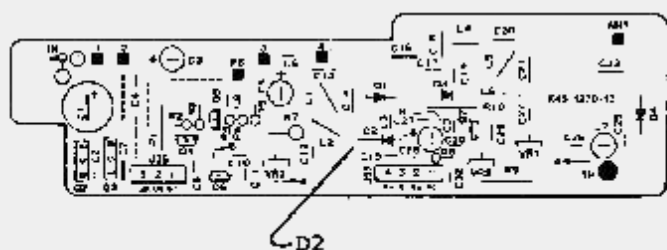

Fig. 1



Fig. 2

Note: This is an optional change and may not be performed in-warranty.

19-07-1998**(TR-8300) TR-8300 Alignment****Author:** Trio-Kenwood Communication, inc.

Service bulletin no. 16 (02-06-1977)

The TR08300 is a 440 MHz FM transceiver that is factory tuned to transmit from 445.0 MHz to 450 MHz and receive from 442.0 MHz to 447.0 MHz.

However, in some areas the operating ranges are different. The TR-8300 may be retuned for these other operating ranges. All adjustments should be made in the center of the 5 MHz range desired.

RX ALIGNMENT:

Adjust the oscillator coil L14 1/2 to 1/4 turn counterclockwise until the LED in the channel indicator window turns on. This indicates that the oscillator is now working. Connect a signal generator to the TR-8300 and adjust L15, L16, TC-6 and TC-7 for maximum "S" meter indication. (These should be very small adjustments.) Adjust TC-5 in the helical resonator for maximum "S" meter indication. This is the only adjustment made to the helical resonator.

TX ALIGNMENT:

Connect a wattmeter and dummy load to the TR-8300. Adjust the oscillator coil L3 for maximum RF output. No other transmitter alignment should be necessary.

19-07-1998**(TR-8400) TR-8400 auf 9k6***de DG6DBF @ DBOEND. #NRW.DEU.EU*

Hallo !

Ich habe hier noch die Anleitung wie man den Kenwood TR-8400 (altes PLL-Rastermonster) auf 9k6 Umbaut. Dabei ist noch eine Modifikation wie man die Umschaltung auf senden verbessern (verschnellern) kann.

Hier nun die Modifikationen:

Das tuning des TXDelays hab ich ausprobiert, leider hatte ich keinen 390 Ohm Widerstand zur Hand, mit 470 Ohm kommt man auf 160mS Umschaltzeit.

Obs noch schneller geht probier ich nochmal aus wenn ich die notwendige Modifikation für 9k6 vorgenommen habe, mangels Modem hab ich das noch nicht in angriff genommen. Dann kann ich auch was über Tauglichkeit usw. berichten.

73s Holger dg6dbf @ dk0mwx

*de DL1YDD @ DB0IZ***TR-8400 Transmit Delay Time**

PLL lockup time when switching from receive to transmit may be shortened for faster transmitter response. This change applies to units before serial number 1060455.

On the PLL unit X50-1670-xx, check the values of R31 (390 ohm) and C47, C48 (6.8uf) near Q7 and Q8. If these component values differ, change as required. This will give approximately a 0.12 second delay, which should be satisfactory for practical use. However, if shorter delay is required, replace R31 with an 820 ohm resistor. This will yield an approximate 0.096 second turn-on delay.

No adjustment is required after this part change.

Note: When R31 is 820 ohms, CTCSS (Subtone) will be slightly distorted.

Installation time for this procedure is 1/2 or less.

de DL1ZAX @ DB0EAM

Hallo 9600 Baud User

Da ich auf meine Anfrage "Umbau Kenwood TR-8400 auf 9600 Baud" keine Antwort bekommen habe, blieb mir nichts anderes uebrig es selber zu versuchen. Dank der Hilfe von DB8AS und DG9FU war das dann auch gar nicht so schwer.

Das RX-Signal kann man auf der Platine "RX.TX UNIT(X44-1340-61)" an der Diode D7, nach der Spule L10 abgreifen. Diese Platine ist auf der Unterseite von dem Geraet, also da wo der Lautsprecher ist. Die Diode ist links neben der Stelle wo der Lautsprecher bei geschlossenem Deckel sitzt (Bedienelemente zeigen zu Ihnen). An D8 kann man die Abschirmung des Verbindungskabels zum G3RUH Modem anschliessen, sie liegt auf Masse.

Das TX-Signal wird ueber ein Relais der Diode D1 zu gefuehrt. Diese Diode befindet sich auf der Platine "PLL UNIT(X50-1670-61)" unter dem Blech, hinten links auf der Oberseite des Geraetes. Das TX-Signal vom G3RUH-Modem muss ueber ein Relais angeschlossen werden welches von der PTT des TNC2 geschaltet wird. Bei Empfang darf das TX-Signal nicht an der Diode anliegen. Dazu habe ich das PTT Signal ueber den freien Pin von der Mikrofonbuchse zum Relais im innern des Geraetes gefuehrt. Das Relais hat zwei Kontakte, ueber den einen wird das PR-Signal geschaltet und ueber den anderen Kontakt wird die PTT vom TR-8400 geschaltet. Dadurch kann man das Geraet auch nach dem Umbau mit einem Mikrofon betreiben ohne das es zu problemem kommt.

Dieser Umbau arbeitet ohne Probleme.
Fals noch fragen sind, nur mut...

vy 73 de DL1ZAX Dietmar @ DBOEAM

This modification is read 462 times.

[top of page](#)

19-07-1998

(TR-8400) TR-8400 Transmit Delay Time

Author: Trio-Kenwood Communication, inc.

Service Bulletin no. 855 (25-1-1982)

PLL lockup time when switching from receive to transmit may be shortened for faster transmitter response. This change applies to units before serial number 1060455.

On the PLL unit X50-1670-xx, check the values of R31 (390 ohm) and C47, C48 (6.8uf) near Q7 and Q8. If these component values differ, change as required. This will give approximately a 0.12 second delay, which should be satisfactory for practical use. However, if shorter delay is required, replace R31 with an 820 ohm resistor. This will yield an approximate 0.096 second turn-on delay.

No adjustment is required after this part change.

Note: When R31 is 820 ohms, CTCSS (Subtone) will be slightly distorted.

Installation time for this procedure is 1/2 or less.

This modification is read 443 times.

[top of page](#)

19-07-1998

(TR-8400) TR-8400 Transmitter Freq Response, Voice or DTMF

Author: Trio-Kenwood Communication, inc.

Service Bulletin no. 853 (25-1-1982)

Operator complaints of insufficient lows in transmit, or faulty Autopatch operation traceable to incorrect twist (high to low tone group balance) may be remedied by changing two capacitors at the mic amplifier input.

On the RX/TX unit X44-1340-11, change C62 and C65 from 0.1uf to 1.0uf, 35v tantalum (CS15E1V010M) to increase low frequency transmitter frequency response. Adjust Deviation (VR3) or mic gain (VR2) as necessary.

Installation time for this procedure is 1/2 or less.

This modification is read 435 times.

[top of page](#)

Author: Trio-Kenwood Communication, inc.

Service Bulletin no. 843 (18-2-1981)

When installing a sub-audible encode in a first-lot radio, change the Tone switch power source from the 8C (common) to the 9T (transmit) line. This will prevent the encoder from distorting the receiver when the Tone switch is ON.

Precedure.

1. Remove the bottom cover (2 long screws, rear, 3 short screws, front) and unplug the speaker.
2. Cut the GRAY lead to the Tone switch wiper one inch from the switch. Tape-insulate the long lead to the harness.
3. Connect the switch wiper to the Mic connector, pin 5.
(See Fig. 1)
4. Install the encoder, connect the speaker, and replace the bottom cover.

For complaints of distorted sub-audible tone in a first-lot unit, replacing components and readjusting the PLL will reduce or eliminate distortion.

Procedure.

1. Remove the top cover (4 screws).
2. Remove the rubber conductive shield.
3. remove the aluminum cover from the PLL unit X50-1670-xx (17 screws).
4. Unplug connectors J2-J6.
5. Remove 11 screws and 2 threaded studs securing the PLL printed circuit board. Shift the board to the rear, then swing up and to the right.
6. Use Wicket or a desoldering tool to remove and replace:

Component	was	replace with (vicinity of Q7)
R30	12 Kohm	18Kohm 1/4W
R31	820 ohm	390 ohm 1/4W
C47	6.8uF	15uF Tantalum (observe polarity)
c48	6.8uF	15uF Tantalum (observe polarity)

Note: Don't create solder-bridges or lift the foil.

7. Reverse steps 5, 4, 3 to partially reassemble.
8. Perform the PLL adjustment listed in the Service Manual, page 24, item 2.
9. Reverse steps 2 & 1 for final assembly.

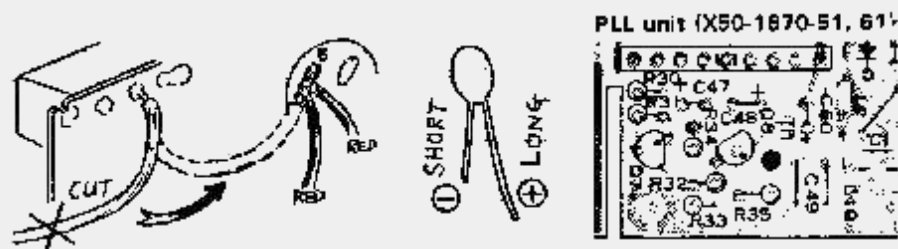

Receiver internal spurious signals occurring at xx1.7 MHz and xx6.7 MHz may be reduced or eliminated by adding an additional ground and bypass capacitor in the PLL. These are third overtone (21.6 MHz) products of the PLL IF (7.2 MHz). This applied to all units before S/N 111xxxx.

Procedure.

1. Remove the top cover (4 screws).
2. Remove the rubber conductive shield.
3. Remove the aluminum cover from the PLL unit X50-1670-xx (17 screws).
4. As illustrated, solder a jumper between the DBM and VCO compartments.
5. Solder a .01uF 50V disc ceramic capacitor (CK45F1A103Z) from the DBM shield to the case of Q4 (3SK76 or 3SK92).
6. Reverse steps 3-1 to reassemble.

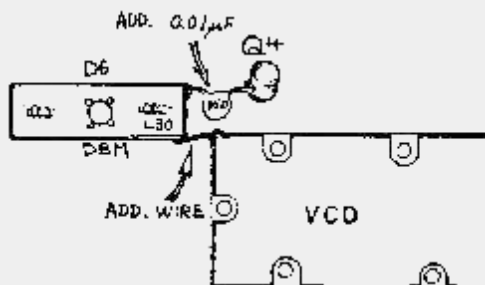

Note: Installation time for this procedure is ½ hour or less.

This modification is read 434 times.

[top of page](#)

19-07-1998
(TR-851) TR851E & TR751E with 9600

Hello, Carl!

I have read one of your messages - you have asked for modifications of TR851.

I am also using TR851E (European Version) and TR751E with my 9600 BD- Modem (G3RUH) with the following modifications:

When you remove the bottom panel, you can see immediately all you need to do the modifications:

- Varicap Diode D21
- IF-Filter CF1
- Discriminator IC2

View from bottom side:

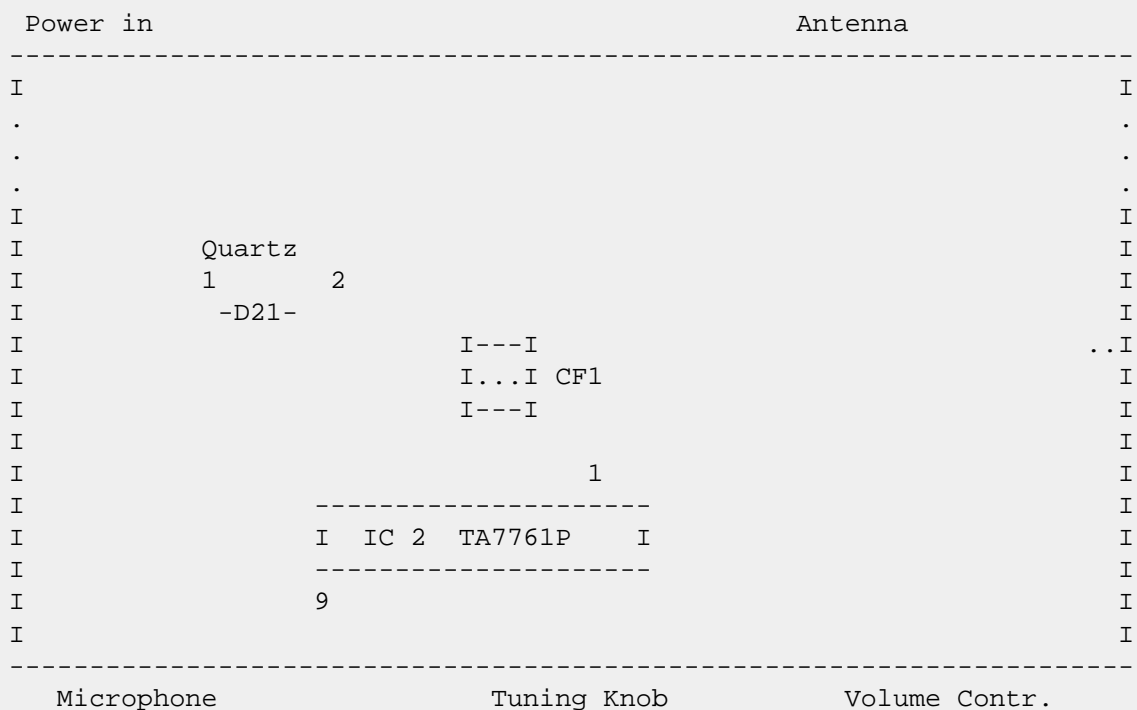

IC 2 Discriminator
PIN 9 of IC 2 -----> - Capacitor (100nF) -----> -RX-Audio G3RUH-Modem

D21 Varicap-Diode
Pin 2 (has no ring!!) -----> TX-Audio G3RUH-Modem

IF-Filter (G3RUH recommends changing)
Replace CF1 (55 F) with CFM 455 D

I thought that the replacement of CF1 was too difficult for me. So I have asked a good friend to remove the PCB and to replace the filter...no problem, he said, and for him it was really not a problem.

The other modifications I have done by myself .
I have done the same modification to TR751 without changing the IF-Filter, because I only need TR 751 for uplink.

The components on the PC Board are close one to another, but I think that other TX/RX are more problematicly to modify.

This modification is read 532 times.

[top of page](#)

19-07-1998

(TR-851) TR851 & 9600 Bps

TR-851: Salida de audio del discriminador.

Para obtener el audio desde el discriminador en este equipo, la operaci3n es muy sencilla, pues ya la tenemos en un conector, que soportar el m3dulo opcional DCL.

1. Localizar el conector 2 en la placa Composite Unit (RX). Esta se encuentra en la parte inferior del equipo. El conector est pr3ximo al frontal.
2. Soldar un hilo (deber ser apantallado), al pin 1 del conector 2; la malla al pin 2 del conector 2.
3. Llevar el cable apantallado a un conector, o bien aprovechar uno de los agujeros a ambos lados del equipo, que servir3an para el soporte de m3vil.
4. Si accidentalmente se produjera un cortocircuito en este cable, no supondr3a da3o alguno, pues en serie tenemos R139 de 33K, lo que nos evitar3a el deterioro de IC2.
5. Si ya se encuentra conectado el m3dulo DCL, no se ver afectado su funcionamiento.

Eso es todo. No he realizado medidas de respuesta en el receptor, aunque puedo afirmar que se obtendr3 un ancho de banda suficiente para los requerimientos del modem de 9600 de G3RUH.

En mi caso, yo uso habitualmente el TR-851 para recibir al UO-14, sin ning3n tipo de problemas.

This modification is read 491 times.

[top of page](#)

19-07-1998

(TR-851) Umbau TR-851E > 9600Bd

Es ist Vollbracht, ich habe mein TR-851 E für 9600 Baud, naja umgebaut ist wahrscheinlich der falsche Ausdruck! Man könnte eher sagen "angezapft".

Im Grunde genommen war es einfach, wenn da nicht immer diese Felsen rumliegen würden, die man sich selber in den Weg gelegt hat, um dann im richtigen Moment drüber zustolpern. Aber das ist eine andere Story.

Also nun endlich die Anzapfgeschichte: als erstes Schaltplan raus und mit dem Finger den feinen schwarzen Linien, die von der Mikrofonbuchse über ein paar Ecken gehend, hinterher (hab inzwischen schon einen Bleistift genommen). Irgendwann kam ich dann bei der COMPOSITE UNIT (RX) (X60-1320-0) raus. Dort habe ich mir für die Modulation die Diode D21 ausgesucht. Die ist im Plan gleich rechts unterhalb des MIC AMP. Die NF wollte ich an einem Stecker abgreifen der mit der DCL-Auswertung verdrahtet ist und bei mir nicht benötigt wird, da in meinem Gerät sowas nicht drin ist. Der Stecker befindet sich im Schaltplan auf auch auf der Composite Unit und da wiederum auf der unteren Seite im ersten drittel von links und trägt die Bezeichnung: "2". Am Pin 1 steht mir, über den R134 (33k) ausgekoppelt, die NF zur Verfügung. Von Pin 2, dieses Steckers, habe ich gleich die Masse abgegriffen.

Nun zu den Örtlichkeiten im Funkgerät. Man öffne den Deckel unterhalb der Funke, ich sag das bloß deshalb weil man meistens den falschen aufmacht (so gehts mir jedenfalls), und schon sitzt man vor der Composite Unit!

Vorsicht Lautsprecherkabel!!

Zum leichteren auffinden der Diode und des Steckers gebe ich Lage der Bauteile Quasi im Koordinatensystem an. Das Gerät liegt also sozusagen Kiel-oben und mit dem Bedienteil zum Bauch (sofern vorhanden) gewandt da, dann habe ich die linke, zum Körper zeigende Ecke, zum Nullpunkt erklärt.

Die Diode befindet sich ca. 73mm nach rechts und 88mm nach oben, der Stecker 61mm nach rechts und 55mm nach oben und ist auf der Platine mit J2 markiert.

Ich kopple die Modulationsspannung, an die D21 über einen zusätzlichen Widerstand (bei mir 22k) ein, den ich von oben an die

Kathode gelötet habe.

Die PTT habe ich an den Stecker J204, der sich auf der Control Unit befindet, angelötet. Dazu muß man das Bedienteil wegklappen. Der J204 ist nicht weit weg von der Mic Buchse.

Ich benütze das 851er in Verbindung mit dem DF9IC Modem, auf der USSC-Karte von Baycom Team. Feine Sache! Wenn ich meine Lötstellen (am Modem) alle durchgezählt hätte, dann wärs auf Anhieb gegangen. Also wenns nicht gehen sollte, obwohl der Digi wie ein Hammer ankommt --- Lötstellen nachschaun.

So nun hoffe ich, daß ich nix vergessen habe.

Meine Rechtschreibung und meine Interpunktion, bitte ich zu verzeihen. Ist halt nicht meine starke Seite.

Viel Spaß, 73 + "96" edi dg1mfx @ db0aab

=====

de DL1SDX @ DBOULM.#BAY.DEU.EU

Zusammen mit etlichen Umbauanleitungen zum TR851 auf 9600Bd haben mich auch einige ebenso interessierte OMs gebeten, ihnen evt. etwa erhaltenen Infos zum Thema zukommen zu lassen. Da das Interesse an dieser Modifikation bzw.

"Anzapfung" also verbreitet ist, im Folgenden ein Auszug aus verschiedenen msgs, die ich bekommen habe, und für die auch entsprechende Erfolgsmeldungen vorliegen.

Für die Richtigkeit der Angaben kann ich nicht garantieren,

Selbst probiert habe ich die Anpassung noch nicht, da momentan noch kein entsprechendes Modem. Urheberrechte habe ich natürlich auch keine berücksichtigt jedoch nochmals herzlichen Dank an alle fleißigen Schreiber!

9600 Baud mit dem Kenwood TR-851E

Sinnge.maess:

* Die TX-Ltg. vom TNC/Modem wird an die Kathode von
* D 21 ueber einen 22k Widerstand angeschlossen.

* Die RX-Ltg. kann man am Stecker J2 anschließen,
* diese liegt dann ueber R 139 (33k) an
* Pin 9 des IC 2 **Achtung, siehe unten!!!**

Genau so bin ich auch bei dem "Umbau" des Gerätes vorgegangen. Leider stellte sich im Betrieb heraus, dass einige Pakete von mir nicht aufgenommen werden konnten.

Daraufhin entschloss ich mich, mir ein Service-Manual zu kaufen um der Sache mal auf den Grund zu gehen.

Wie ich nun herausfand, hat sich im Schaltbild ein kleiner Fehler eingeschlichen. Und zwar endet die andere Seite des R 139 nicht Schaltbild eingezeichnet am Pin 9 des IC 2, sondern zwischen C 67 und C 66. Somit ergibt sich, wenn ich mich nicht irre an dieser Stelle ein wunderschönes RC-Glied (Tiefpass) Und der "nuppelt" dann anscheinend, dass EIN oder ANDERE weg. (Herausgefunden durch Vergleichen des Schaltbildes mit dem Layout)

*****Schliesst man nun die Ltg. anstelle an J 2 direkt an Pin
*****IC 2 an, so funktioniert das sofort korrekt.*****

Mit dem so "angezapften" Gerät und einem TNC 2 H konnte ich in TCP/IP auf einer ruhigen Frequenz in FTP einen mittleren Datendurchsatz von 755/sec. erreichen.

Ich hoffe dem EIN oder ANDEREN damit geholfen zu haben und wünsche allen weiterhin ein froehliches Basteln und viel Spass in 9k6.

UNTERSEITE VOM TR 851

*

*

*

* hier R22 KOhm TX an 180° DIN PIN 1 zum TN

*

* |
* + _____D21

*

* IC 2

* IC-TA 7761 @-----~

* +-----+

* RX PIN 9 + +PIN 15 Masse an DIN

*

* an DIN 180° PIN 4

*

*

PTT an Stecker hinter Display löten an weißen Stecker, mit Ohmm prüfen, dann an PIN 3 180° DIN St. zum TNC.
alles klar?

Und noch eine Variante, etwas verfeinert, im Prinzip aber wie oben:

Ich betreibe seit ca. 1 Jahr die in 9K6 und das ding rennt "wie Sau"...hi also...

TX:

als erstes die Kap. Diode D21 suchen, nebenan sitzt ein Xtal mit 10,695MHz an die Kathode lötest du VORSICHTIG und ZÜGIG einen Widerstand mit 27K damit gehst Du direkt über ein abgeschirmtes Kabel zum TX-OUT des Tnc.

RX:

Den Stecker 2 suchen und am Pin RD vorsichtig die Isolierung etwas entfernen. Dort wird auch ein Kabel angelötet, die Abschirmung direkt daneben an Pin E. Den Stecker findest Du auf der Unterseite, Front zum Bauch an der Kante zur Front ca. 2cm von Links.... Die beiden Kabel habe ich auf die MIC-Buchse gelegt und dort dafür einfach 2 Pins zweckentfremdet, zb MR und M-UP. Dadurch hat man keine losen Kabel rumhängen.

Wenn Du gleichzeitig in 1K2 umschaltbar Betrieb machen willst, dann musst Du am 3105 den Vorwiderstand entfernen, damit Du auf ca. 1VSS kommst.

Der RX-Pegel reicht voll und ganz aus, und bei schwachen Signalen unter S4 macht das 9K6 Modem bei mir nurnoch Rejects.....was solls

Wichtig ist, das Du die Sende-Nf beim Empfang nicht abzuschalten brauchst!!!!

Mit dem TX-Delay konnte ich in einem Link mit einer anderen 851 auf 5 herunter, alle andern Parameter auf Kampf. Damit schafft man ca. 850/s, schneller geht nicht...hi

So, viel spaß beim Umbau und schreib mal, wie es klappt

Ich hoffe, damit einigen von Euch geholfen zu haben, wie gesagt, ich gebe diese Infos nur an die allg. Kenwood-Rubrik weiter, der Inhalt stammt aus Infos, die mir auf eine entsprechende Anfrage freundlicherweise zugingen.

73's und awdh,

Robert, DL1SDX @ DBOULM

This modification is read 516 times.

[top of page](#)

19-07-1998

(TR-9000) TR-9200/TR-9000 Optional Ceramic Filters

FM Adjacent channel rejection in either unit may be improved by installing an optional narrow ceramic filter.

Filter	Part No.	-6db Bandwidth	-70db Bandwidth	Retail
CFK-455F	L72-0304-05	+/- 6 kHz	+/- 12 kHz	33.50
CFK-455G	(CFK-455G)*	+/- 4 kHz	+/- 10 kHz	33.50

* Not original part. No computer part number.

Location: TR-9200, RX unit X55-1270-10 part, L10
TR-9000, RX unit X55-1260-11 part, CF1

To install, desolder the original filter and clear the second set of holes for the optional filter. Solder the new filter in place. Be sure all pins are actually soldered, and that there are no solder bridges between pins or across the printed circuit board. Clip the pins flush to the board, and reinstall the circuit board.

Note: Squelch operation will vary from unit to unit with an optional narrow filter. Tighter coupling from the detector to the squelch circuit may be tried to restore "original feel".

This modification is read 713 times.

[top of page](#)

19-03-2000

(TR-9000) TR-9000 CW, SSB TX instability

Author: Trio-Kenwood Communication, inc.

Service Bulletin no. 824 (29-5-1980)

Complainte of FMing in SSB, or CW chirp may be eliminated by minor changes to the TX mixer circuit.

On the TX unit X56-1370-10, perform the following changes:

1. Cut the LT foil path.
2. Install a 47 ohm resistor on the foil side of the PCB.

3. Remove R27, 3.3 Kohm and delete.
4. Jumper the cut foil.
5. Install a 2.2 Kohm resistor from Q12 Collector to the modified LT foil on the foil side of the PCB.

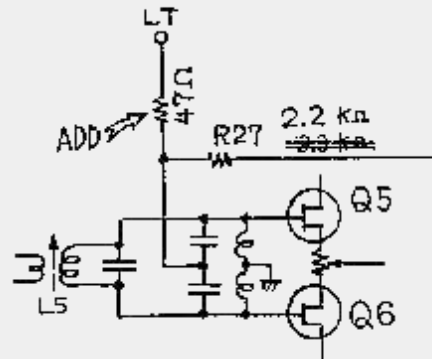
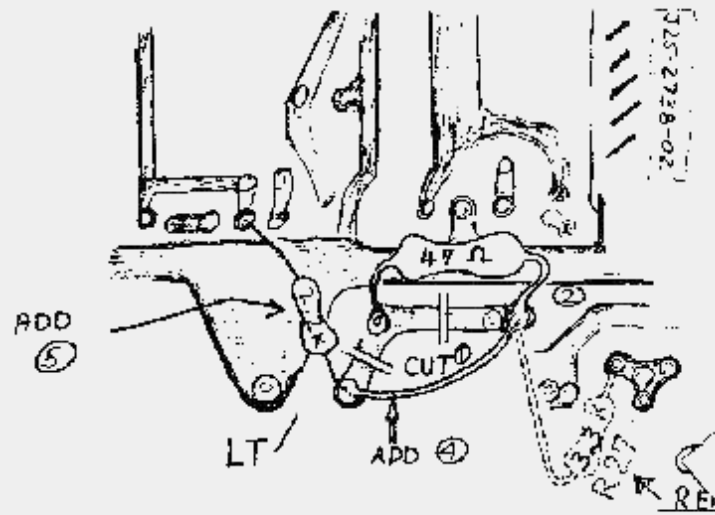

This modification is read 744 times.

[top of page](#)

19-03-2000 (TR-9000) TR-9000 TX pulse noise in SSB mode

Author: Trio-Kenwood Communication, inc.

Service Bulletin no. 825 (2-6-1980)

Pulse noise heard during SSB transmission may be reduced or eliminated by adding one capacitor to the TX unit.

On the TX unit X56-1307-10 add a 22uF 16V radial lead cap to the PMB line, as illustrated, on the foil side of the PCB. No adjustment are necessary.

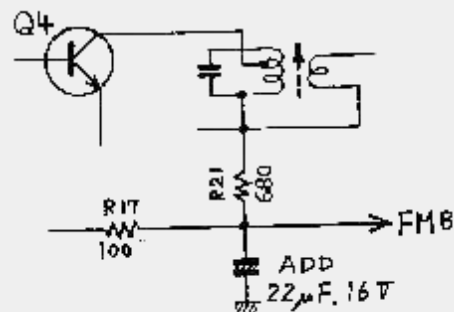
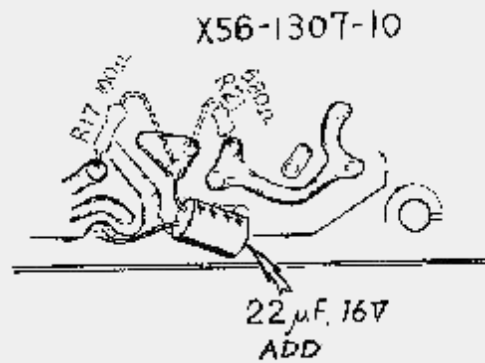

This modification is read 698 times.

[top of page](#)

Author: Trio-Kenwood Communication, inc.

Service Bulletin no. 849 (30-7-1981)

Distorted sideband transmission may have one of two causes. If normal alignment docs cure the problem, distortion or poor carrier suppression may be improved by rerouting two leads in the wire harness.

Perform these initial checks first:

1. On early units, ascertain that R74, 47 ohm is on the TX unit X55-1370-10 between connector 33, the LT line, and R27, 2,2 Kohm (vicinity of Q5, Q6), and that R27 is 2.2 Kohm. (Service Bulletin #824).
2. Verify TR-900 Service Manual alignments, General section steps 4 (PLL), and 5 (HET frequency alignment).
3. TX section, steps #4 (power adjustment), 9 (SSB mic gain), 10 (carrier point) & 11 (carrier suppression).

Procedure:

1. Remove the bottom cover and unplug the speaker.
2. With the radio upside down and facing forward, locate connectors 8 and 10 at the front of the RX unit X55-1260-00. Connector #8, pin 3 (violet) is the -6V DC line from the TX unit, connector # 31, pin 1. Connector # 10, pins 7 (signal) and 8 (ground) (green coaxial cable) is the MS pins 5 (sig) and 4 (gnd).
3. Carefully cut the cable ties (without cutting any leads) securing these two lines in the wire harness which runs to the left, around the upright Control unit, and then right behind the front panel ad far as the Mode switch.
4. Carefully unplug each of these connectors by gripping the connector housing with a long-nosed plier.
5. Extract the terminal from the housing by depressing the locking tab and simultaneously withdrawing the lead with terminal. (See illustration below).
6. Reroute these two lines from the behind the Mode switch, between the chassis and control unit, then left to their original connectors. Reinstall the terminals in their original positions in the connector housing.
7. Coil the excess of each lead and secure with cable ties. Retie the harness behind the front panel, along the left of the chassis, and back behind the control unit.
8. Readjust carrier suppression. Mod SW:USB, Mic terminal terminated with 470 ohm. On the RX unit, alternately adjust TC1 & VR6 for minimum output at 145 MHz. Carrier should be at least -40dB down.
9. Work is complete. Replace the bottom cover.

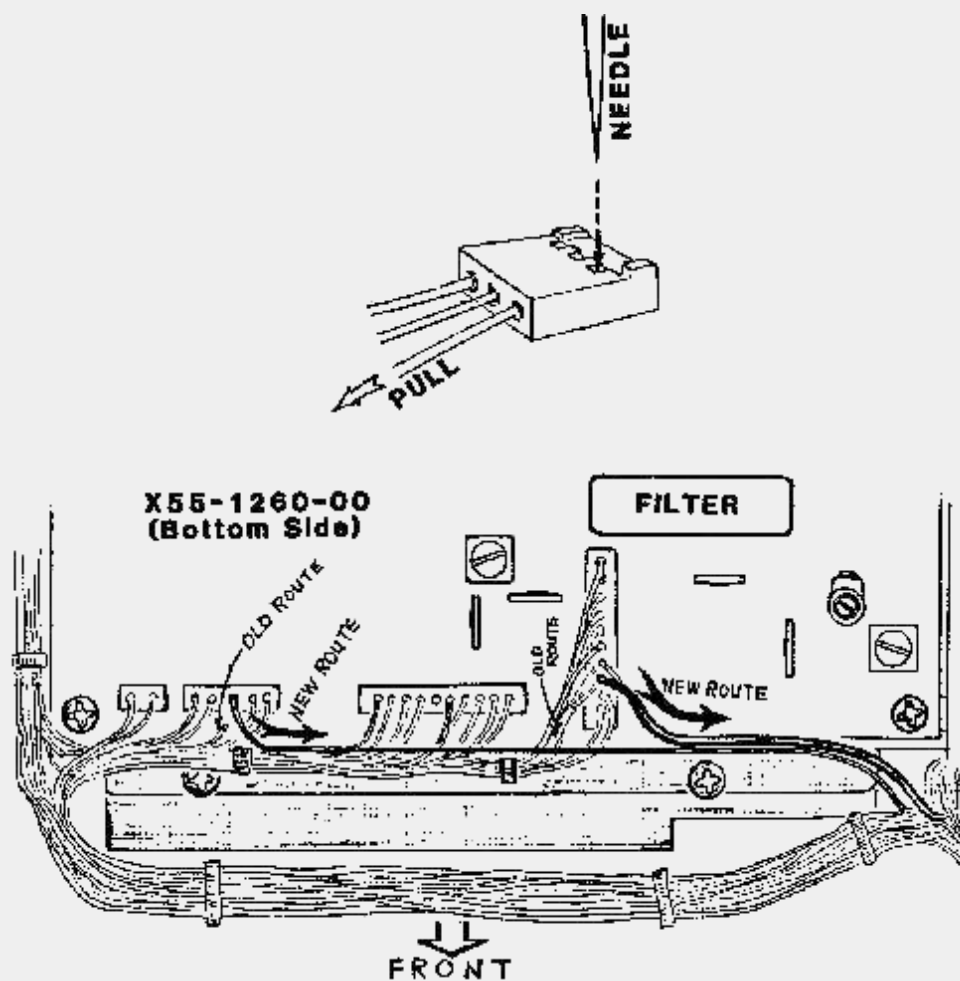

08-04-2000

(TR-9000) TR-9000 Temperature Stability Improvement

Author: Trio-Kenwood Communication, inc.

Service Bulletin no. 859 (14-4-1982)

PLL noise or unlock at high temperature may be cured by changing a mixer feed point in the PLL.

Measure TP3 on the PLL unit. If greater than 0.5V RMS signal is available, this change will not be required. If less than this level is present proceed.

On the PLL unit X50-1620-00 at Q13:

1. Remove and delete C23.
2. Connect Q13 emitter to L5 "hot" (original C23 take-off.)
3. Realign L5, 6, 7 for at least 0.5V RMS at TP3.

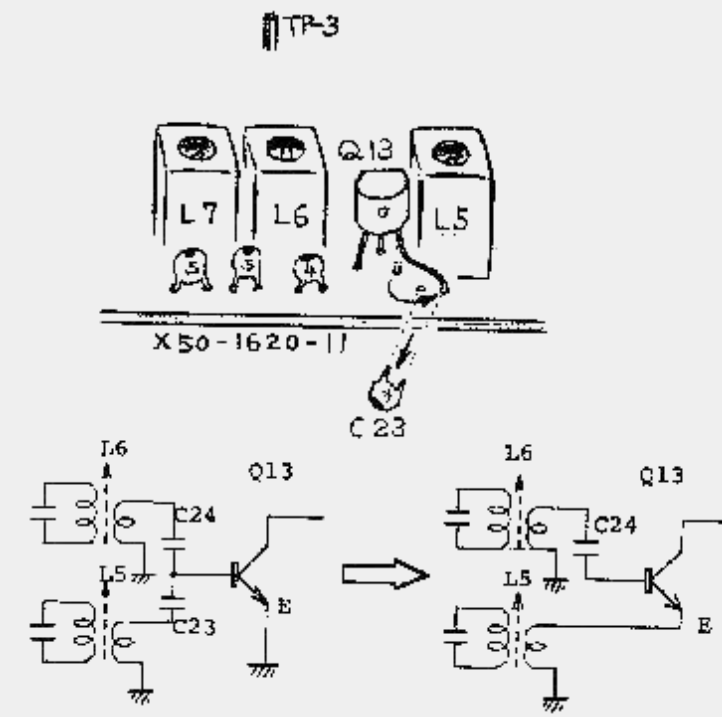

Note: Installation time for this procedure is ½ hour or less.

Alignment note: To align L6 & 7, first position the slugs flush with the tops of the coils, then alternately adjust these two coils for maximum output at the first peak into the coil (fundamental frequency). Then align L5 for maximum.

This modification is read 726 times.

[top of page](#)

19-07-1998

(TR-9130) TR-9130 Low Drive Level

Author: Trio-Kenwood Communication, inc.

Service Bulletin no. 871 (5-7-1983)

For reported cases of low transmit power output check the level of the TX driver transistor Q7 of the Drive unit (XS7-1090-00). If the TX drive level is low make the following changes.

	Old Part	New Part
Q7	3SK97	3SK122(L)
R36	100 ohms	68 ohms

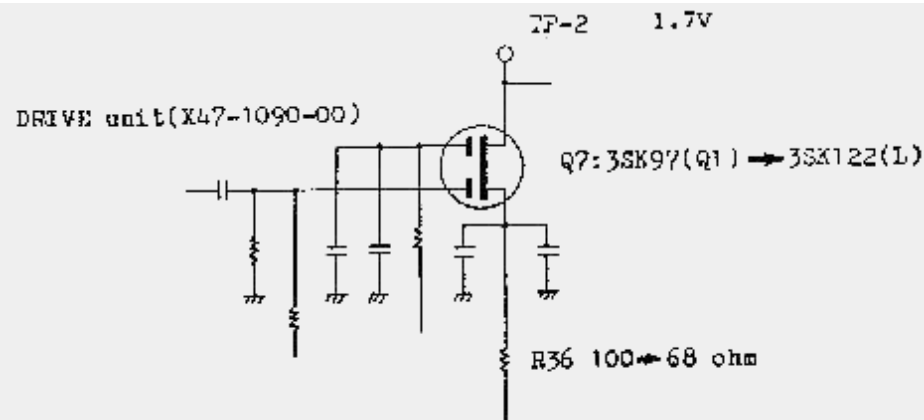

Time required for this change is 1/2 hour.

This modification is read 612 times.

[top of page](#)

19-07-1998

(TR-9200) TR-9200/TR-9000 Optional Ceramic Filters

FM Adjacent channel rejection in either unit may be improved by installing an optional narrow ceramic filter.

Filter	Part No.	-6db Bandwidth	-70db Bandwidth	Retail
CFK-455F	L72-0304-05	+/- 6 kHz	+/- 12 kHz	33.50
CFK-455G	(CFK-455G)*	+/- 4 kHz	+/- 10 kHz	33.50

* Not original part. No computer part number.

Location: TR-9200, RX unit X55-1270-10 part, L10
 TR-9000, RX unit X55-1260-11 part, CF1

To install, desolder the original filter and clear the second set of holes for the optional filter. Solder the new filter in place. Be sure all pins are actually soldered, and that there are no solder bridges between pins or across the printed circuit board. Clip the pins flush to the board, and reinstall the circuit board.

Note: Squelch operation will vary from unit to unit with an optional narrow filter. Tighter coupling from the detector to the squelch circuit may be tried to restore "original feel".

This modification is read 206 times.

[top of page](#)

19-07-1998

(TR-9250) TR-9250 RF LED Meter

The RF LED meter may show reduced output after continuous transmission, while output actually remains constant. Changing components on the final unit will correct this problem. This change applies to units before serial number 201XXXX.

Procedure:

1. Remove the top cover (four screws), and unplug the speaker.
2. Remove the bottom cover (four screws).
3. Remove four screws holding the heatsink and swing the sink down.
4. Without changing coil spacing, desolder L6 which connects from the ANT pad on the final unit to the PL-259, at the final unit.
5. Remove five screws holding the final unit pcb X45-1180-10, one screw holding Q6 2SD880, and two screws holding the final hybrid module Q1, M57726.
6. Change the following parts:

C15 1pf to 2pf (CC45CH1H020C)
 D3 1N60 to 1S1587 (V11-0370-05)
 R8 820 ohm to 1.2K (RD14CD2E122J)

7. Insure adequate thermal compound on Q1 and Q6, and that the mica washer is correctly positioned under Q6. Reverse steps 5 and 4 to partially assemble.
8. Cable-up power and a dummy load. Readjust VR1 on the final unit at 147.000 MHz, high power setting for 5 LED's ON. Switch to low power and verify 3 LEDs ON.
9. Remove power from the unit and complete reassembly by reversing steps 3, 2, and 1.

Note installation time for this procedure is 1/2 hour or less.

This modification is read 206 times.

[top of page](#)

19-07-1998

(TR-9350) TR-9350/30 RX Interference

Some users have reported FM Broadcast or TV video carrier interference to the receiver. Normally the TR-9350/30 has excellent two signal intermodulation characteristics. For a reported case of Broadcast or TV IMD the following modification may reduce or eliminate the interference.

Parts Required

Qty Description

1 MI-308 Diode

Procedure

1. Remove the top and bottom covers.
2. Remove the 4 screws that secure the heat sink assembly to the rear of the set. Gently pull the heat sink assembly to the rear, to allow access to the final unit X54-1270-1-,11.
3. Remove the 5 screws securing the PC board to the heat sink. Remove the 2 screws securing the final module (M57733/M57726) and remove the screw that secures Q2 to the heat sink. Carefully desolder L9 from the antenna connector. (Dont change the spacing of the coils!!!)
4. Gently fold the assembly over to allow access to the foils side of the final assembly and remove D2, and replace it with the MI-308 diode.
5. Reverse steps 1-3 to reassemble. Reconnect L9 but don't change the spacing of the coils. Use heat sink compound when replacing the final module.

This modification is read 224 times.

[top of page](#)

19-07-1998

(TR-9500) TR-9500 fuer 9600bd

Hallo 9600 Baud Fans,

hier ein kurzer Hinweis, wie ich mein 9600 Baud Modem von G3RUH an meinem Kenwood TR9500 angeschlossen habe. Verbesserungen sind sicherlich moeglich. Die Empfangs-NF nehme ich ab an der Verbindung R42/R43 auf der IF-Unit. Das Sendesignal speise ich ein an der Verbindung C18/C19 auf der CAR-Unit. Die PTT-Leitung verdrahte ich wie gewohnt. Nun viel Spass beim "High-Speed-PR" auf 70cm.

Ciao es vy 73 de Werner, DL5DAA @ DB0IZ

This modification is read 276 times.

[top of page](#)

19-07-1998

(TS-120) Hum in SSB TX, TS-120S and others

Author: Trio-Kenwood Communication, inc.

Service bulletin no. 48 (9-8-1979)

Some TS-120S users may complain of a hum during SSB operation, which may be caused by RF feedback. There may be various reasons for this complaint.

1. Bad feedline and antenna system ground.
2. Poor Mic hookup or shielding.
3. Vertical antenna with poor or no radial system.
4. For base operation with other than a PS-30 Power supply:
Poor regulation and insufficient filtering in the supply.
5. Linear amplifier creating hi RF field near the operating position.
6. RF induced back into the power supply causing false protection (other than PS-30).
7. RF pickup by any cables to or from ancillary equipment.

Prevention is the best cure. For those cases where all normal measures have been tried, try installing a .01uF bypass cap across the mic input jack between pins 1 and 4.

Some AFSK operators may have similar RF feedback problems with TS-820S or TS-520S. Bypass the mic ground pin to the chassis, pin 3 to 4 and in extreme cases, install a ferrite bead on the Mic coax center conductor at the microphone connector.

Please annotate your service manual.

19-07-1998**(TS-120) TS-120S VFO Stability****Author:** Trio-Kenwood Communication, inc.

Service Bulletin no. 827 (6-6-1980)

(Supercedes 7/9/79 bulletin)

VFO drift characteristics may be improved by changing component values and location in the VFO.

This change applies to serial numbers before 00100001.

Note: DO NOT disturb lead dress or component placement while working inside the VFO.

1. Remove the VFO unit by four 3mm hex head bolts.
2. Withdraw out the front panel and unplug the leads.
3. Remove the VFO cover by 5 phillips head screws.
4. Remove C17, and C18 from the PCB. These may be cut flush to the board.
5. Reposition the Ground terminal for the Variabel Capacitor by heating the post and pushing it through to the opposite side of the PCB.
6. Install paralleled 10pF green and 18pF yellow caps from the bottom tank coil terminal (LH) to the modified Ground post. Position the caps near the coil, not the PCB. Make certain the ground lead doesn't touch the coil or coil mounting.
7. To reassemble, perform steps 3,2,1. Snug all VFO case screws. A later complaint of frequency jump would indicate a loose VFO shell.

New Parts: 10pf CC45SG1H100J
18pf CC45RG1H180J

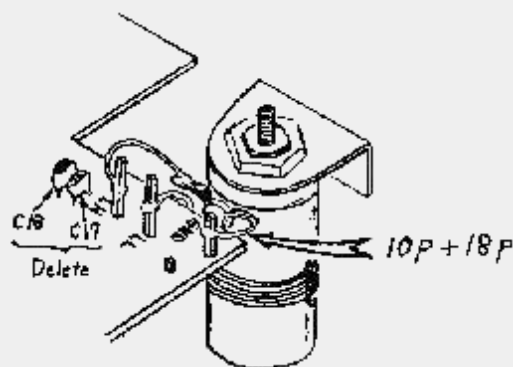
**Analog Dial Calibration:**

1. Turn the main dial fully CCW. The red cursor should line up with the VFO mark on the sub-dial. If it does not, remove the main knob, loosen set screws and align the scale start point with the red cursor.
2. Turn the main knob to 50 kHz analog. Adjust the aluminum slip sub-dial to line up with any one of the larger black dial marks.
3. Note the digital error. If it is MORE than 2 kHz adjust the VFO trimmer cap TC1 (center under the seal tape) to exactly 50.0 on the digital readout.
4. Turn the main knob to 450 analog. If the digital error is less than 2 kHz it is in spec. If the digital error is greate, proceed:

For instance if the digital error is 14.454.0 (plus 4 kHz), multiply the error times 4 (16 kHz) and adjust the VFO trimmer cap to the desired frequency (14.450.0) less the error, or 14.434.0. Next adjust the VFO inductor L10 (front under the seal tape) back up to the desired frequency of 14.450.0.

5. If the error in step 4 was in the minus direction, reverse the direction of correction adjustment in step 4.
6. VFO linearity final check: The digital readout and analog dial should agree to within +/- kHz at every 100 kHz dial point.

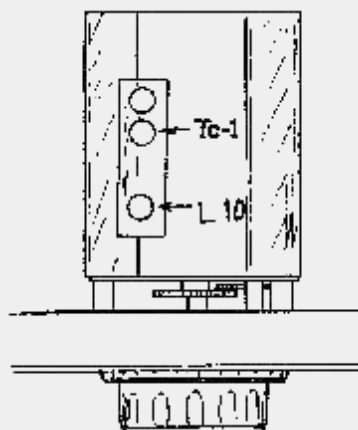

19-07-1998

(TS-120) TS-120S VOX operation pick-up time

Author: Trio-Kenwood Communication, inc.

Service bulletin no. 37 (10-7-1979)

High speed CW ops may inquire about partial loss of the first character when operating VOX-CW. The transceiver will operate up to about 20WPM before this is apparent.

Improvement may be had by changing three components on the RF Unit X44-1260-01.

Production later than serial # 940701 has this change.

Please notate your Service Manual.

R33 100K ohm, change to 150K ohm
R52 33K ohm, change to 4.7K ohm
C62 .022 uF, Change to 1 uF @ 50v

▼ RF UNIT (X44-1260-01)

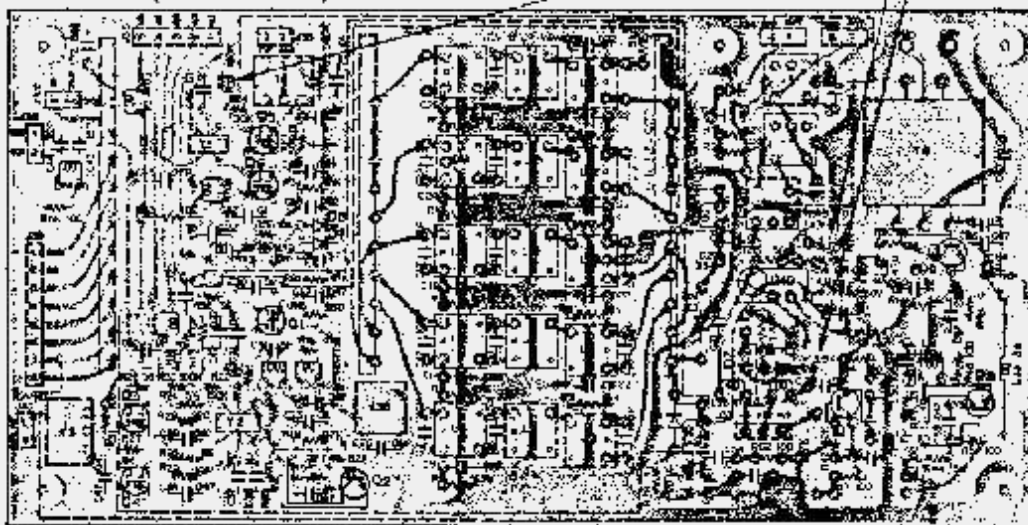

This modification is read 1024 times.

[top of page](#)

19-07-1998

(TS-120) TS-120S Final Transistor Replacement

Author: Trio-Kenwood Communication, inc.

Service bulletin no. 38 (10-7-1979)

When ordering single replacement 2SC2290 Final transistors for the TS-120S, please specify the hfe rank, by color. When replacing pairs of finals, always select the same hfe rank for both transistors.

Rank designation will be found printed on the transistor, directly under the transistor number.

Rank :	R	30-65
	O	55-95
	Y	85-150

Please return all defective 2SC2290 finals to the attention of the TRIO- KENWOOD service department, along with the warranty claim form.

This modification is read 1182 times.

[top of page](#)

19-07-1998

(TS-120) TS-120S Ant Input Transformer Replacement

Author: Trio-Kenwood Communication, inc.

Service bulletin no. 40 (12-7-1979)

Ts-120S transceivers subject to strong static fields or similar high current atmospheric discharges may suddenly exhibit low RX sensitivity on all bands. TX will be OK. You may suspect T1 on the RF unit X44-1260-01.

When replacing or ordering T1, L43-0696-35, also check the value of C20.

If it is 33pF, just replace and repeak the transformer.

First production transceivers will have a 15pF cap for C20. When changing T1, also replace C20 with a 33pF capacitor, and repeak the circuit.

Old part number: L34-0696-05 Antenna Coil

New part number: L34-0696-35

Old Capacitor was 15pF, replace with

New part number: CC45RH1H330J 33pf

This modification is read 1046 times.

[top of page](#)

19-07-1998

(TS-120) TS-120 Repair Notes

Author: Trio-Kenwood Communication, inc.

Service Bulletin no. 60 (18-12-1979)

Symptom	Repair
No CW, No Audio	Sidetone oscillator Q25 on AF GEN unit 2SC1815
Receiver Sens Down	T1, L34--696-35 on RF unit Shorted
Analog Dial Cal OFF	Mechanical Adjustment
Carrier in SSB	RF unit D2 and D3 shorted see TKC Service Bulletin
Loss of Digital	Check P5/J5 on Carrier Unit
Smoke at Final Unit	Check for long eds of wire shorted to case inside final unit also burned L10 and L11, L40-1011-04 (100uH)
SSB Audio bad	IF shift control turned max CW
Power on Meter Max	The RF gain control was turned max CCW
VFO freq drift	Replace the TEMP comp CAP C17
TX Audio BAD	Check the Carrier Point adjust and make sure final bias is set to 150 Ma
PLL digital NG	Check D15 PLL unit
High IC in RX	Check the Final transistors
15 Meters only	The BCD rotary band switch has a broken wafer.
RX TX only 10M	The BCD divider Q16, 74LS163 on PLL unit bad.
	Check the BCD inputs against the pin 2 frequency.
28.5 HF Osc	Check ground screws and tighten at Relay Unit X41-1250
No CW Filter	Solder short across pins 1-2 J29 IF Unit
No RX	After the CW filter was installed the pins were not cut off shorting the signal to ground.
Analog dial off	Perform VFO tracking adjustment at 50 and 450
TX out 40M only	40M 50W and 10M 10W bad finals
No 15M	Core on the VCO transformer for 15M broken
3.5 and 7 Band same	Shorted trace at Band switch under IF unit
Low RF out	All bands, Q12 SN16913 on AF gen unit, 2SK19GR bad
No TX all bands	L25 open on the RF unit Small gree inductor
No digital no TX	Q12 mixer on the PLL unit bad
No RX no digital	Q26 mixer on PLL unit bad
INtermitt SSB AUdio	Pin 5 of J5 on AF GEN unit loose
No key or TX	D26 and Q24 2SA562 on AF gen unit bad
No TX	R8 220 ohm at key jack burned open. Make sure customer uses shielded line on CW KEY.
15M osc.	On 15M band only with antenna HF oscillation when first speaking. Install Ferrite bead on base of first mic amp Q18 AF GEN UNIT.
No TX	Loss of AVB Voltage at RF unit. Check Q9 2SA473 on the filter unit, also check 6 volt Zener diode.

19-07-1998**(TS-120) TS-120S Band Pass Filter Change****Author:** Trio-Kenwood Communication, inc.

Service Bulletin no. 816 (7-2-1980)

For complaints of out of band interference, especially BCI, the BPF (Bandpass filter) terminating resistors may be changed for an improvement of approximately 10dB.

On the RF unit X44-1260-01 change R3,5,7,9,11 from 1.5K ohm to 470 ohm. No adjustments are required.

19-07-1998**(TS-120) TS-120S TX oscillation****Author:** Trio-Kenwood Communication, inc.

Service Bulletin no. 844 (21-5-1981)

The TS-120S may exhibit intermittent oscillation on the 15M, 10M and/or 20M bands. Symptoms may be no control of Carrier level, full current or ALC in either CW or SSB after initial keying or modulation, or "full output both forward and reflected".

1. Physically disconnect power from the radio.
2. Make certain the Antenna fitting is tight to the rear panel.
3. Remove covers. Unplug speaker lead.
4. Check for loose screws securing the RF unit X44-1260-01 and the relay unit X41-1250-00 (located over the RF unit).
5. On the RF unit, check diodes D2, 3 and 8 for high reverse leakage. If in doubt, replace.
6. If not already present on the RF unit, make the following changes:

R47 (33 ohm) change to 10 ohm Radial (RD12CY2E100J)

R50 (560 ohm) change to 680 ohm Radial (RD12CY2E681J)

C61 (220 pF) Remove

Add 2 1S1587 (V11-0370-05) diodes in series, anode to ground from the junction of C4 and D8.

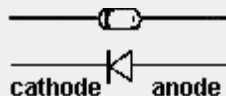

Note: Diode I.D. 1S1587 = 1S1585. Added diodes may induce RX IMD. If se, delete.

7. As illustrated, carefully cut the cable ties on the wire harness (without cutting the wires) as it rounds the corner behind the PLL unit X50-1490-00.
8. Separate the AVB line, a white/brown line from the filter unit X51-1200-00 to the RF unit X44-1250-01.
9. Adjacent to the rear of the PLL and to the left you will see a five pin terminal strip. The two right-hand most terminals are bridged. Without breaking the terminal or strip, remove the heavy yellow, and light red and green lines and transfer them to the adjacent terminal. There will now be seven lines, plus the positive end of the C1 on the second terminal. Be sure to cut the wire jumper between these two terminals.
10. The free terminal will be a tie point for the AVB line bypass capacitor. Solder a .01uF 50V disc ceramic (C52-1710-36) between ground and the first free terminal. Use spaghetti to insulate the leads. Then solder the AVB line to the .010uF cap.
11. Re-secure the cable harness with nylon cable ties (J61-0401-05).
12. Replace the covers and speaker lead. Power-up and verify correct operation.

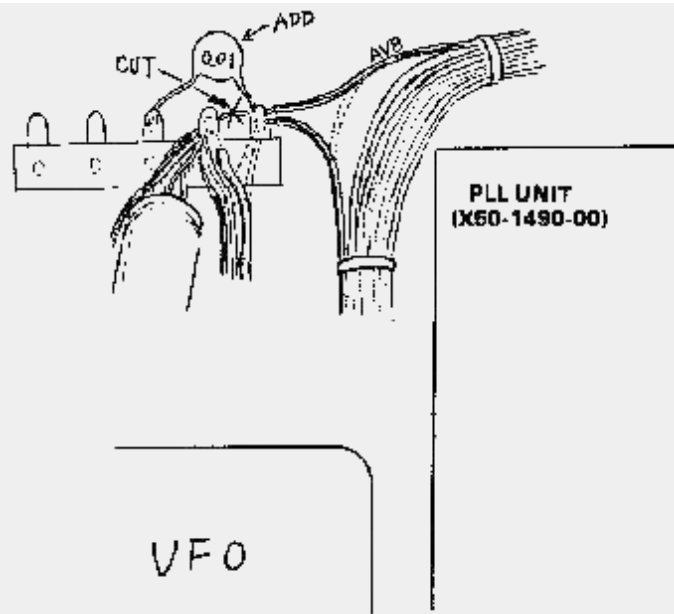

Note: Installation time for this procedure is approximately ½ hour.

This modification is read 1152 times.

[top of page](#)

19-07-1998

(TS-120) TS-120S Full CW output in ssb mode

High reverse leakage, or shorting of D2 and sometime D3 on the RF UNIT X44-1260-01, will provide an unwanted DC voltage path which gives full CW output while in the SSB mode. Carrier control has no effect, and RX is not affected.

Replace D2, 1S2588, check D3, 1s1587, and install an additional diode, D8, a 1S1585 on the foil side of the RF unit.

To install, swing the rf unit up. Remove the shield from under the IF unit, exposing the foil side of the RF unit. Using a razor or X-ACTO Knife, carefully cut the land between C4 and C20. Solder the additional 1S1585 across the the cut and observe polarity. Replace D2, the 1S2588. Some RF units have a 12 PF cap soldered on the foil side of the board, across T1; C20 will be missing.

Remove the 12 PF cap, and install C20, 33 PF in the board.

Production later than 080001 has this change.

This modification is read 1106 times.

[top of page](#)

14-01-2000

(TS-120) TS-120V: Reduced RX current consumption

Author: Joachim Seibert - dl1gsj@qsl.net. MODIFICATION.NET

The TS-120V is equipped with a two bulb lightshow. Remember that the chassis really warms up above the VFO-scale and the S-meter...

I replaced the two bulbs with green ultra-bright LEDs and matching resistors in series. The resistors give you a chance to adjust a pleasant illumination level (I always felt the lightbulbs beeing to bright). As standart LEDs are a little thicker than the original Kenwood bulbs one need to cut off a part of the VFO-scale lighting rubber mounting sleeve's rear portion. Cut of the bulb's wires close to the glas body, they will perfectly serve the new LED-R combinations.

Experience:

- RX current went down by 300mA
- scales do not dazzle anymore in a darker shack
- chassis does not heat up as fast as before (still some heat above the frequency counter)
- => less VFO drift than before

I will not sign responsible for any damage produced with this modification!

This modification is read 1101 times.

[top of page](#)

20-02-2000

(TS-120) TS-120S, TS-180S phone patch terminal addition

Author: Trio-Kenwood Communication, inc.

Service bulletin no. 44 (6-9-1979)

Kenwood recommends the PC-1 Phone Patch for all of our radios. Most other phone patches will work satisfactorily without any modification to the radio, requiring only an external speaker connection, and that the Mic line be run through the patch.

For those operators who desire a Patch input similar to the TS-520S or TS-820S, an input connection and terminal must be added at the Mic input preamp circuit.

Fixed Divider

Use a 100Kohm in series, with a 10Kohm to ground on the input side of the 100Kohm resistor. Use shielded line, and connect as follows:



TS-120S

On the IF Gen unit X49-1110-01 install the fixed divider at the junction of R43 10K, C42 100pF, & C43 1uF (input of Q18). Add an RCA jack, or use remote pins 7 and ground for input.

TS-180S

On the IF Gen unit X48-1240-00 install the fixed divider at the junction of R167 10K, C128 .001uF, & C129 1uF (input of Q32). Add an RCA jack, or use remote pins 7 and ground for input.

This modification is read 1008 times.

[top of page](#)

20-02-2000

(TS-120) TS-120S Final protection

Author: Trio-Kenwood Communication, inc.

Service Bulletin no. 51 (27-7-1979)

If for any reason work is performed in the Final unit, install two additional parts to the Filter unit X51-1200-00. This will improve protection action.

Procedure:

1. Remove top and bottom covers.
2. Remove Final unit (6screws).
3. Filter unit X51-1200-00 will be exposed. Install between Q3 Base, and TP1, series wired diode and resistor D14 and R34.

No adjustment are necessary

New part number D14 1S1555 V11-0076-05
R34 4.7Kohm

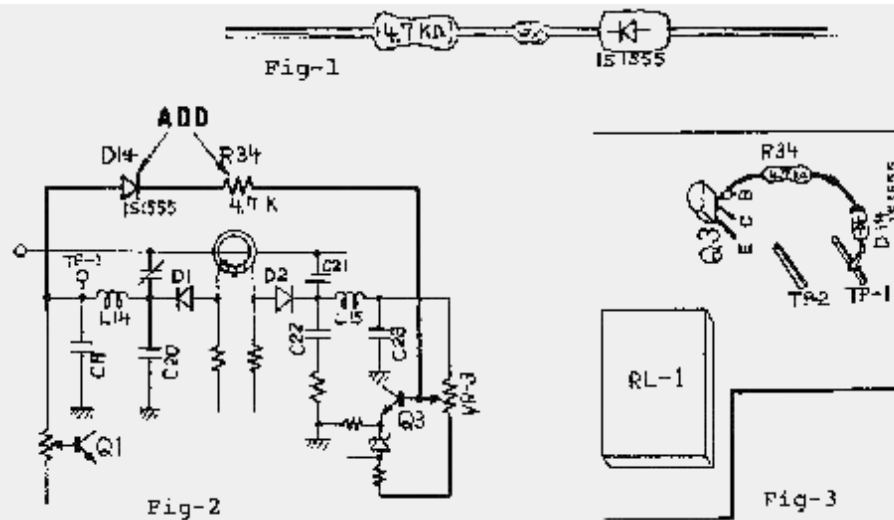

Please notate your Service Manual

This modification is read 1144 times.

[top of page](#)

19-03-2000

(TS-120) TS-120S Ant input transformer replacement (2)

Author: Trio-Kenwood Communication, inc.

Service Bulletin no. 831 (12-8-1980)

TS-120s Ant Transformer Replacement: New Part.

Supercedes bulletin #40 7/12/79

Transceivers subject to strong static fields, high RF, or similar high current atmospheric discharges may suddenly exhibit low sensitivity on all bands. TX will not be effected. Suspect T1 on the RF unit, X44-1260-01.

When replacing T1, L43, 0696-35, check that the value of C20 is 33pF. Early units may have a 15pF for C20, and may have T1 as L43-0696-05. In either case, replace the transformer with an L43-0929-15. If C20 is 15pF, replace it with a 33pF capacitor. Since T1 is a broadband transformer, no adjustment is necessary.

In addition, add two 1S1587 diodes after the transformer as shown to further protect the receiver.

Installation time for this procedure is approximately ½ hour.

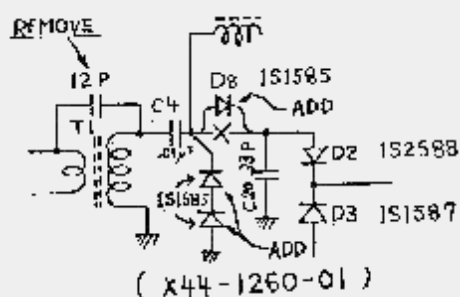

This modification is read 1061 times.

[top of page](#)

14-11-2001

(TS-130) TS-130S TX oscillation

Author: F6HQP Marc - Marc.Dumonal@ac-grenoble.fr. MODIFICATION.NET

The problem is full output both forward and reflected on 20 and 17

The modification is made after read "TS-120S TX oscillation" of 19/07/98

- remove up cover (8 screws)
- remove the "relay unit X41-1300-00" (2 screws)

- remove the screw under the "relay unit" on the "RF unit X44-1380-00" just near the coil L48. Put a terminal and replace the screw. The terminal is now to the ground.
- solder a 10nF ceramic between the terminal and the coil L48.
- replace the "relay unit" and the cover.

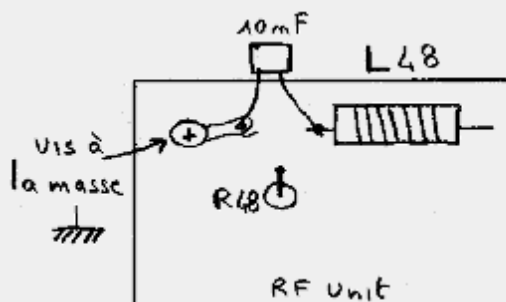

F6HQP Marc

This modification is read 938 times.

[top of page](#)

19-07-1998

(TS-140) TS-140S Sidetone Mod

I recently purchased a Kenwood TS-140S after using it on CW for about a week, I decided to try it on SSB and AM. When I pushed the AM and SSB mode switches, I heard a constant audio tone emanating from the rig. As I disconnected the rig, preparing to return it to the factory, the tone stopped.

Investigating the circuit diagram, I noted that the CW key has to be unplugged to kill the sidetone. There is no mention of this in the Instruction Manual.

Perhaps my experience may save others the frustration I encountered.

Also, amateurs should pay attention to the proper use of receiver noise blankers. I know of instances where operators were handing out reports of distorted signals to others, only to discover that it was their improper use of the receiver noise blanker that was producing the distortion...

Ed, W6XM

This modification is read 1453 times.

[top of page](#)

19-07-1998

(TS-140) TS-140S Intermittent loss of TX power

Author: Trio-Kenwood Communication, inc.

Service Bulletin no. 928 (11-4-1988)

In some TS-140S transceivers, the drive transistor, Q2, is not firmly mounted to the heatsink. This can cause a loss of transmit power after the unit warms up. The following modification will correct this condition.

1. Disconnect the TS-140S from the antenna and power supply.
2. Remove the top and bottom covers. Open the sub-chassis. Refer to the instruction manual for step by step instructions.
3. Remove the shield plate from the sub-chassis (12 screws) to expose the filter and final units. Do not loose the 2 springs that are secured by the right side screws.
4. Resolder Q2 so that the transistor makes firm contact with the heat sink on the Final unit. Tighten the transistor's mounting screw. (See the diagram below).
5. Assemble the transceiver by reversing steps 1 through 3.

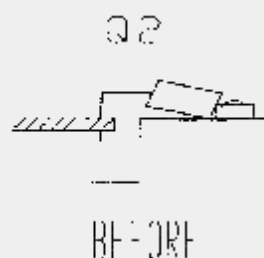

This modification may be performed under warranty.
Time required for this change is 1/2 hour or less.

This modification is read 1485 times.

[top of page](#)

19-07-1998

(TS-140) Broadcast Sensitivity Modification for the TS680S / 140S

Between .500 and 1.6 MHz attenuation is added to reduce? front-end overload on the Broadcast band. Some of us BCB DXers find this a HIGHLY undesirable feature. If I want attenuation I will use the front panel switch. The following mod will restore the sensitivity -
Cut the land between IC1 pin 11 and R7 (SIGNAL UNIT, M54581P)

Cut the trace between IC1 pin 12 and R10

Add a small signal diode (1N914, 1N4148) between IC1 pin 11 and R7 (Cathode towards R7)

Add a small signal diode between IC1 pin 12 and R7 (Cathode towards R7)

Trace the lands from pin 11 and 12 of IC1 and you will find a good place (to the left of connector CN5) to cut these traces as well as pad to solder the diodes to.

This modification is read 1461 times.

[top of page](#)

19-07-1998

(TS-140) TS-140S TX All Freq Mod

To enable the TS-140S for transmitting on all bands:

1. Disconnect radio from power supply and antenna
2. Remove top and Bottom covers
3. Locate the control board (I believe it is on the bottom --NOT BEHIND TH THE KNOBS LIKE THE 440!!)
4. Cut D31 on the control board
5. Reassemble the radio
6. Reset the radio by holding the A=B switch while powering up the rig.

Disclaimer: This Modification is for those who need it to operate MARS only.

This modification is read 1945 times.

[top of page](#)

16-04-2000

(TS-140) TS-140S Momentary transmission when VOX is turned on

Author: Trio-Kenwood Communication, inc.

Service Bulletin no. 929 (11-4-1988)

When the VOX switch is turned on immediately after the power switch is depressed, the TS-140S may trip into the transmit mode. This condition can be corrected by changing the value of chip capacitor C504 on the Signal unit. The following procedure will detail how to access the capacitor.

Required parts:

C504 0.001 μ F, 50V chip capacitor (CK73FB1H102K)

1. Disconnect the TS-140S from the antenna and power supply.
2. Remove the top and bottom covers (12 screws). Remove the 4 sub-chassis mounting screws. Swing the sub-chassis to the left to expose the Signal unit. If required, refer to the instruction manual for illustrations.

Note: Refer to figure 1 for the next steps.

3. Unplug the wires at connector CN4, CN12, CN18, CN19, and CN20.
4. Remove the nine screws from the signal unit.
5. Slide the Signal unit forward until the external speaker jack clear the back panel cutout.
6. Carefully lift the Signal unit up from the back side and rotate it toward the front panel to expose the bottom of the board.

7. Locate chic capacitor C504 on the bottom of the board (see figure 2). If required, refer to the service manual board diagrams for details.
8. Unsolder and remove the C504.
9. Install and solder the .001 μ F capacitor in place of C504.
10. Assemble the transceiver by reversing the above steps.

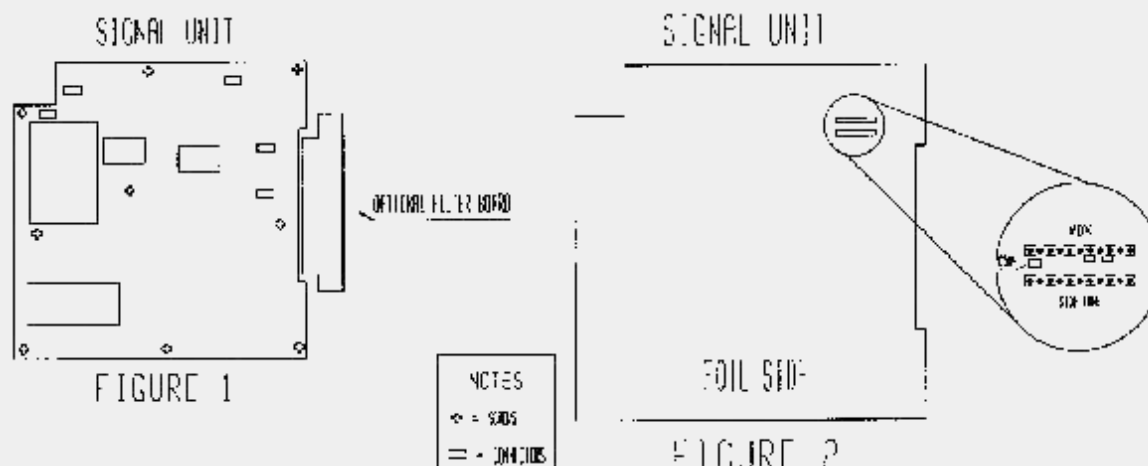

This modification may be covered under warranty.
Time required for this modification is 1 hour or less.

This modification is read 1286 times.

[top of page](#)

15-11-2001

(TS-140) Kenwood TS-140S tip

Author: Bernd DH4MBM - ufp@neusob.de. MODIFICATION.NET

I had much problems with my Kenwood TS140-S and no Circuit Diagram..

The digits of the display began flickering after about 10 minutes and the display showed nonsens. The relais of the PA made much noise... After switching the trx off it worked again .. for ten minutes.

The kenwood homepages were no help either...

I opened it carefully, disconnected all HF connectors and cleaned them with a rubber gum (I don't know the exact term, but I mean that thing I drove my teacher mad in drawing !) and it was a little better. After a tip from packet radio, I removed the EProm on the Upper platine (circuit board) and cleaned its legs V E R R Y carefully on the same way. Now the TS140S works properly since 8 weeks.

73 de Bernd DH4MBM

This modification is read 1464 times.

[top of page](#)

19-07-1998

(TS-180) TS-180S Trouble Sheet

Author: Trio-Kenwood Communication, inc.

Service Bulletin no. 61 (18-12-1979)

ALC deflection low Replace D21 on IF unit from 7.1 to 9.0V zener.
Readjust all ALC pots.

IF #2 Output low Bridge R77 position, replace R78 with R77 470 ohms. See TKC service Bulletin.

RX Noise (OSC CAR leakage) Shorten L31, L33 leads as much as possible.

Increase NB effectiveness Replace L31, L33 for 33 uh to 27uh, with SHORT leads.

RX noise from strong signals Replace L30 10uh on the IF with self shielding type (new part L40-1035-21).

TX audio distortion Adjust T15 on the IF approx 1/2 turn back, readjust all ALC pots up.

10 M PLL unlock change: R77 from 6.8 K to 4.7 K ohm, R94 from 8.2 K to 6.8 K ohm on the PLL unit.

TX audio distortion Adjust 10 W bias for 150mA, 100 W bias for 100mA.

Unlocked all bands Check L2, (Q2 B+) in the PLL unit.

FM'ing with DFC See service bulletin of 9/10 for L12, L13 change and add resistor and shield.

40 Mlow alc, See bulletin 9/14 change C14, 17.

This modification is read 725 times.

[top of page](#)

19-07-1998

(TS-180) TS-180S Use with a Linear Amplifier

Author: Trio-Kenwood Communication, inc.

Service Bulletin no. 817 (20-3-1980)

1. Fast Protection with a Linear:

For complaints of fast protection, such as when operating CW semibreak-in with a linear, check C73 at the base of Q1 on the LPF unit X51-1180-00. If it is a 1uf, change to 3.3 uf, 25v or greater. This will compensate for slow linear relay closure.

2. Premature Protection

The radio should protect at 3:1 SWR, or at 24W open (no) load. To test the protection circuit, load the radio at 24W into a know 500 ohm dummy load through a Bird 43 wattmeter. Disconnect the load from the wattmeter. The protection light should just lite. Adjust the protection pot VR1 on the LPF unit for protectio at 24W with no load.

3. For complaints of VOX CYCLING, MEMORY JUMP, READOUT JUMP, or TONE "BEEP" at key up or down with a linear amp, suspect linear induced relay transients entering the radio via the ASSY relay wiring.

For example, DRAKE L4B linears before Serial Number 5500 do not have a quench diode across the DC operated relay. Install a 1N4005 or equivalent across the relay in the linear to eliminate the back EMF induced by the linear into the TS-180S. Similarly, Henry linears also don't have a diode across the relay and may give these symptoms when operated with a TS-180S.

This modification is read 659 times.

[top of page](#)

19-07-1998

(TS-180) TS-180S Low Pass Filter Optional Changes

Author: Trio-Kenwood Communication, inc.

Service bulletin no. 41 (4-9-1979)

1. Transmitter ALC levels may be increased by these optional component changes. Check for correct component values when installing the CK-18 kit.

On the LPF Unit X51-1180-00 change:

7 MHz

C14 from 470pf to 390pf (CM93D2H391J)

C17 from 470pf to 390pf (CM93D2H391J)

18 and 21 MHz

C25 from 27pf to 39pf (CC45CH2H390J)

C26 from 82pf to 68pf (CC45CH2H680J)

C28 from 82pf to 120pf (CC45CH2H121J)

C29 from 27pf to 39pf (CC45CH2H390J)

24.5 and 28 MHz

C30 from 18pf to 39pf (CC45CH2H390J)

C34 from 18pf to 39pf (CC45CH2H390J)

All capacitors should be 500V silver mica or disc ceramic, 5%.

ALC Adjustment. After these component changes, perform ALC alignments 4-4, 4-5, and 4-6 as listed in the Service Manual. Be sure to adjust to spec.; incorrect meter zero (4-4), output exceeding 95W (4-5), or failure to peak T1 (RF unit) and L15 (IF unit) (4-6) will result in low or no ALC and possible future damage to the power amplifier.

2. Fast protection with a linear amplifier. While working in the LPF unit, check the value of C73 (base of Q1). If it is 1uf, change to a 3.3 uf @ 25v dc tantalum (CS15E1E3R3M). This will compensate for slow linear amplifier relay closure.

Note:
These changes are at the owners option and may not be performed in warranty.

This modification is read 593 times.

[top of page](#)

19-07-1998

(TS-180) BS-8 Alignment with the TS-180S Transceiver

The SM-220/BS-8 scope combination are fully compatible with the TS-180S transceiver. However, as the TS-180S does not have a 25kHz calibrator, BS-8 alignment will not be in accordance with the SM-220 Operating Manual.

Procedure:

Install the BS-8 in accordance with the SM-220 Manual, however, leave the scope covers off until step 1 is completed (If input alignment.) See note 1.2.

Perform steps 8.4.1, 8.4.2. steps 8.4.3, 8.4.4 do not apply to the TS-180S. After step 8.4.2. continue:

1. With the Marker ON, turn the transceiver ON, and in the USB mode, any band, you should hear the scope Marker directly injected into the IF.
Peak T201, the BS-8 input IF transformer, for maximum signal into the TS-180S. This transformer is not shown in Fig. 8-2, but is the only other adjustment on the BS-8, and is located below the three identified access openings. If you cannot hear the Scope Marker in the TS-180S, turn the marker off and tune a local station on the 1.5 MHz band. Peak the drive control, and then peak T1 in the BS-8 for maximum amplitude at scope center and equal roll-off at the display edges. See note 1 Page 2.
2. Turn on TS-180S, 1.5 MHz band, and tune to the local AM broadcast station nearest 1.6 MHz.
3. Enter this frequency in the M1 Memory. Depress the DSP/Diff pushbutton for a differential display.
4. Tune up and down approximately 100KHz, observing the scope display. Note the vertical displacement of the original frequency to the left and right. If equal, or linear displacement is observed, stop.
5. If the display does not shift equally when tuned up or down frequency, adjust VR202 for linearity of scan width. Then reset to the center frequency (by the scope Marker or retuning the transceiver). Reset TC201 if necessary. Repeat two or three times for correct scope center frequency, and linear display.
6. Turn the TS-180S off, and the scope marker on. Switching between 100kHz and 20kHz scan widths, the marker should appear at scope center, and should not shift. Repeat step 5 if there is a shift.

Notes:

1. A BS-8 previously aligned to a TS-820 or TS-820S need only have step 1., input alignment, performed.
2. Preset TC201, VR201, VR202 at their center. When alignment is complete, these adjustments should not be at their extreme limits. This will result in unstable Pan display operation. Rather, they should be somewhat within their center range.

Please make these changes in your service manual.

This modification is read 619 times.

[top of page](#)

19-07-1998

(TS-180) TS-180S CW Delay During VOX Memory Operation

Author: Trio-Kenwood Communication, inc.

Service Bulletin no. 803 (7-2-1980)

Some operators may report missing the first dit during CW VOX operation on the memories. This will occur only in early units, and may be improved by changing one capacitor in the DFC.

On the DFC VCO unit X50-1550-00, check C3 at the base of Q3. If C3 is a 22uF electrolytic, change to a .01uf disc.

No adjustments are necessary.

This modification is read 573 times.

[top of page](#)

19-07-1998

(TS-180) TS-180S Low 40M ALC

9-14-79

Please annotate your service manual.

Some operators may experience intermittent reduction or loss of ALC, especially after several minutes transmit time.

On the LPF unit X51-1180-00, change C14, C17 from 470 pf to 390 pF. Check ALC level and adjust if necessary, per section 406 ALC meter adjustmet, TS-180S service Manual.

New part: CM93D2H390J 390pF +/- 5% 500v mica or ceramic

Please annotate your Service Manual.

This modification is read 587 times.

[top of page](#)

19-07-1998

(TS-180) TS-180S VFO Stability

Author: Trio-Kenwood Communication, inc.

Service Bulletin no. 839 (29-12-1980)

VFO drift characteristics may be improved by changing a capacitor value and location in the VFO.

1. Begin by calibrating the analog dial to the Digital Display at 14.000.0 MHz. DO NOT disturb this calibration while working on the VFO.
2. Turn off the main power and remove the VFO unit by two 3mm hex head bolts.
3. Withdraw out the front panel and unplug the leads.
4. Remove the VFO cover by five Phillips head screws.
5. Remove C17 from the PCB. This may be cut flush to the board.
6. Install the 18 pF yellow cap across the tank coil terminals. Position the cap near the coil.
7. To reassemble, performs steps 3, 2. Snug all VFO case screws. A later complaint of frequency jump would indicate a loose VFO shell.
8. Turn on the radio and check analog dial calibration against the Digital Display. Adjust VC1 (center of the Seal Tape) only if the zero-point has moved.
9. VFO linearity final check: The Digital readout and analog dial should agree to within +/- 2 kHz at every 100 kHz dial point.

New Part: 18 pF CC45RC1H180J

Old Part: 18 pF CC45PG1H180J

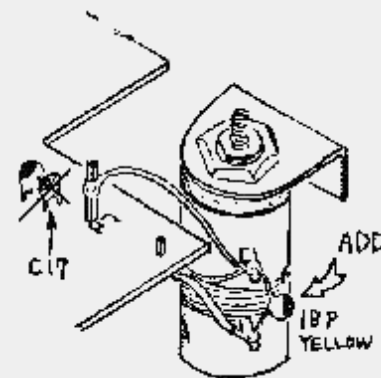

Analog Dial Calibration

1. Calibrate the main knob to 50 kHz analog against the digital display.
2. Note the digital error. If it is more than 2 kHz adjust the VFO trimmer cap VC1 (center under the sealing tape) to exactly 50.0 on the digital readout.
3. Turn the main knob to 450 analog. If the digital error is less than 2 kHz it is in spec. If the digital error greater, proceed:

For instance, if the digital error is 14.454.0 (plus 4 kHz), multiply the error times 4 (16 kHz) and adjust the VFO trimmer cap to the desired frequency (14.450.0) LESS the error, or 14.434.0. Next, adjust the VFO inductor L1 (front under the sealing tape) back up to the desired frequency of 14.450.0.

4. If the error in step 3 was in the minus direction, reverse the direction of correction adjustment.
5. VFO linearity final check: The digital readout and analog dial should agree to within +/- 2 kHz at every 100 kHz dial point.

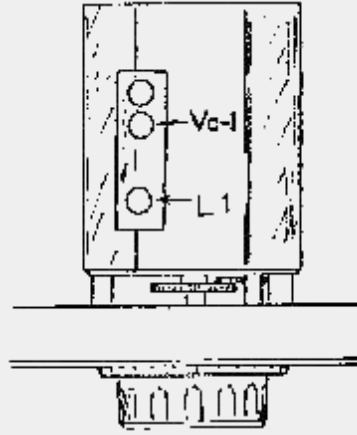

This modification is read 627 times.

[top of page](#)

19-07-1998

(TS-180) TS-180S Increase of RX Audio Output

Author: Trio-Kenwood Communication, inc.

Service Bulletin no. 47 (30-7-1979)

RX audio output from the TS-180S may be increased a total of 4.7 dB. This is an optional change which you can make at the owners request.

On the IF unit X48-1240-00 change components:

R206 2.2K change to 1 K ohm
R207 2.2K change to 4.7 K ohm

On the AF Gain Control, between pin 1 and 3;

C4 .047uF change to .027uF mylar

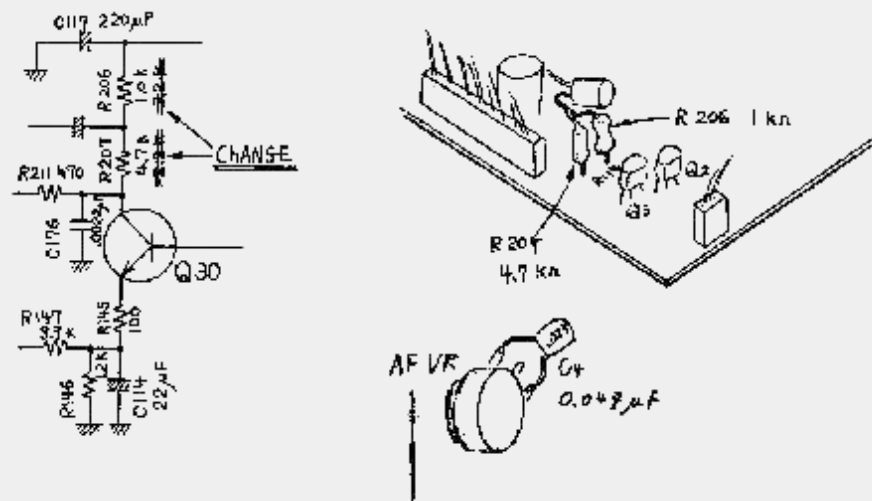

Please notate your service manual.

This modification is read 595 times.

[top of page](#)

19-07-1998

(TS-180) TS-180S IF output #2 Level Change for SM-220

Author: Trio-Kenwood Communication, inc.

Service bulletin no. 42 (4-9-1979)

TS-180S owners who desire to operate an SM-220 for IF output display will require a wiring change to the IF unit X48-1240-00. No additional parts and no adjustments are required.

Remove R77, 470 ohm, and replace with wire jumper. Remove R78, 56 ohm, and replace with old R77. The 56 ohm resistor is not used.

With AGC on, gain should be adequate for about a 3/4 screen display.

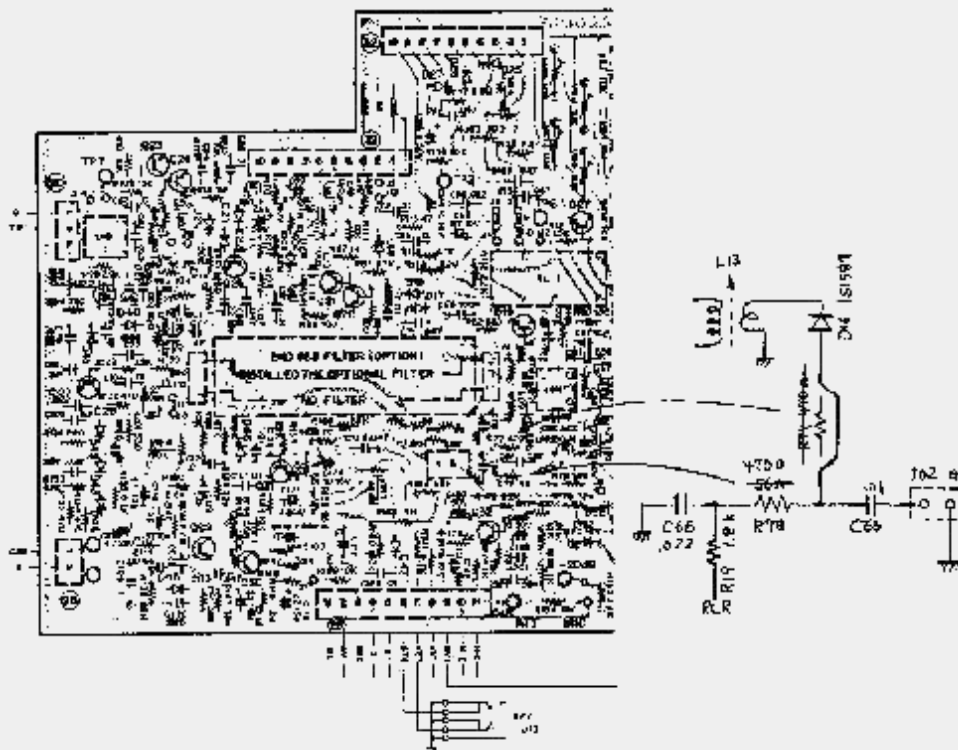

This modification is read 586 times.

[top of page](#)

20-02-2000

(TS-180) TS-180S DFC hum with PS-30

Author: Trio-Kenwood Communication, inc.

Service bulletin no. 36 (10-7-1979)

Some TS-180S users may report erratic DFC, and audio hum. You will find they have placed the PS-30 to the left of the transceiver. Hum is induced from the PS-30 into the DFC.

We are awaiting modification and production changes. Mean while, please be aware of this problem. Temporarily moving the PS-30 to the right hand side of the transceiver will cure the problem. Spacing the two units with the SP-180, or just separating at least two inches will also cure the hum. When full information is available, we will follow up.

Please advise your Service and Sales personal.

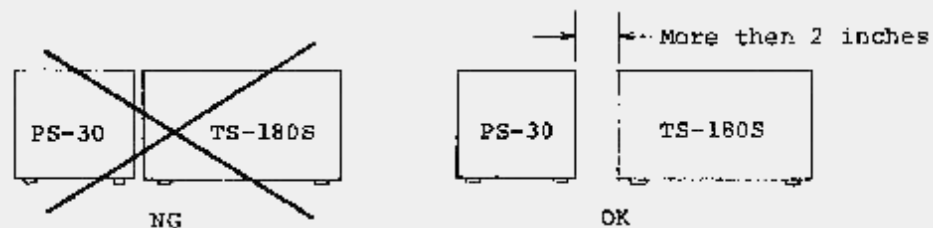

This modification is read 574 times.

[top of page](#)

20-02-2000

(TS-180) TS-120S, TS-180S phone patch terminal addition

Author: Trio-Kenwood Communication, inc.

Service bulletin no. 44 (6-9-1979)

Kenwood recommends the PC-1 Phone Patch for all of our radios. Most other phone patches will work satisfactorily without any modification to the radio, requiring only an external speaker connection, and that the Mic line be run through the patch.

For those operators who desire a Patch input similar to the TS-520S or TS-820S, an input connection and terminal must be added at the Mic input preamp circuit.

Fixed Divider

Use a 100Kohm in series, with a 10Kohm to ground on the input side of the 100Kohm resistor. Use shielded line, and connect as follows:

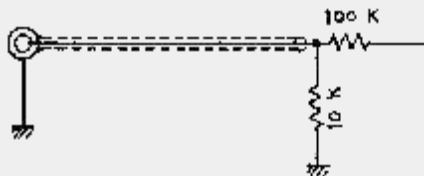

TS-120S

On the IF Gen unit X49-1110-01 install the fixed divider at the junction of R43 10K, C42 100pF, & C43 1uF (input of Q18). Add an RCA jack, or use remote pins 7 and ground for input.

TS-180S

On the IF Gen unit X48-1240-00 install the fixed divider at the junction of R167 10K, C128 .001uF, & C129 1uF (input of Q32). Add an RCA jack, or use remote pins 7 and ground for input.

This modification is read 579 times.

[top of page](#)

18-03-2000

(TS-180) TS-180S DFC

Author: Trio-Kenwood Communication, inc.

Service Bulletin no. 56 (10-09-1979)

For complaints of either induced power supply hum, or intermittent frequency stability while using the DFC, perform the following changes to the VCO unit X50-1550-00:

1. Install a 330 Kohm resistor between Q11 G1 & the 8V line.
Connect from L7 at C12 to Q11 G1, at R35.
2. Replace L12 68uH with new part L40-6831-21.
3. Replace L13 150 μ H with new part L40-1541-27.
4. Install magnetic shield as illustrated. Use the two existing screws, plus double faced tape to prevent vibration.

No adjustments are necessary.

Note: On page 37 of the Service Manual, the VCO Board view shows reversed callouts for Q11 & Q15. D & S, and G1 & G2 are transposed.

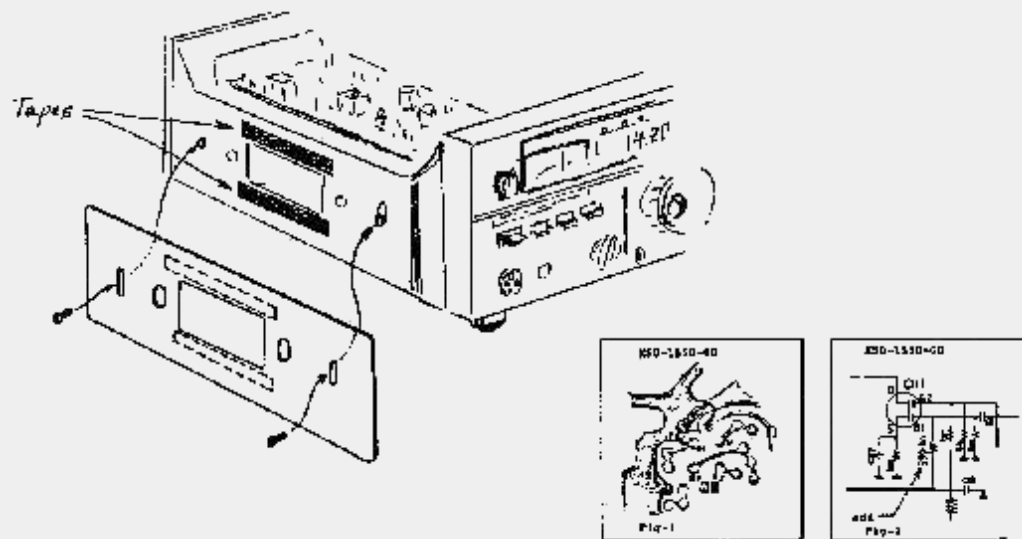

This bulletin supercedes previous DFC bulletins of 7/10/79 and 7/13/79.

This modification is read 611 times.

[top of page](#)

18-03-2000

(TS-180) TS-180S DFC Instability

Author: Trio-Kenwood Communication, inc.

Service Bulletin no. 67 (13-7-1979)

TS-180S operators may report intermittent DFC instability, especially at 10 KHz even points. This may be characterized in some cases as PM'ing.

On the VCO unit X50-1550-00, install a 330 Kohm resistor between Q11 G1, and the 8V line. Connect from L7 at C12 to Q11 G1. at R35.

No adjustments are necessary.

Note: On page 37 of the Service Manual, the Board view of the VCO unit contains reversed callouts for Q11 & Q15 FET's, D & S, and G1 & G2 are transposed.

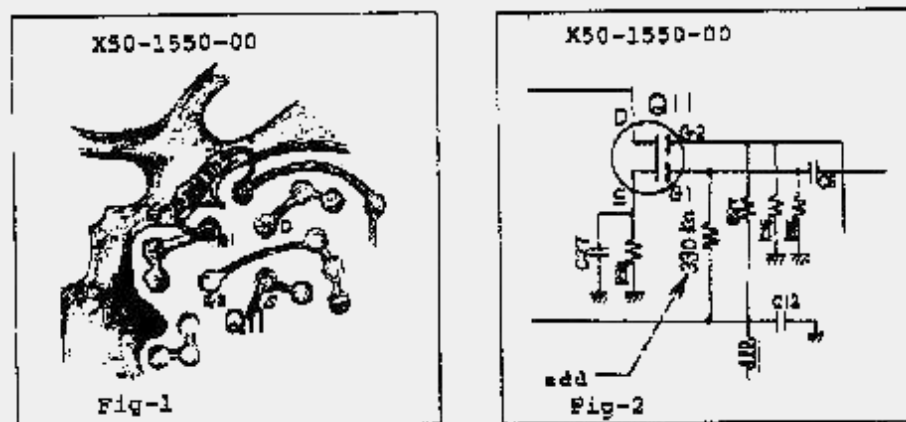

This modification is read 592 times.

[top of page](#)

03-03-2001

(TS-2000) TS-2000 Mars/Cap Mod

Author: MODZO & G4KQU - g4kqu@btinternet.com. MODIFICATION.NET

- Disconnect power cord and antenna from the transceiver.
- Remove the top and bottom covers.
- Remove the top screw from each side of the front panel assembly.
- Loosen the bottom screw from each side of the front panel assembly.
- Carefully rotate the front panel forward to gain access to the control board(X53-3910-11). This board is mounted vertically

against the body of the transceiver. It is not the board that is mounted in the front panel assembly.

- Locate and remove resistor R53 from the control board.
- Assemble the transceiver then perform the CPU reset procedure by holding the A=B button in while turning on the power.

Transmit Range: 1.705-30MHz, 49-54MHz, 142-152MHz, 420-450MHz, 1240-1300MHz.

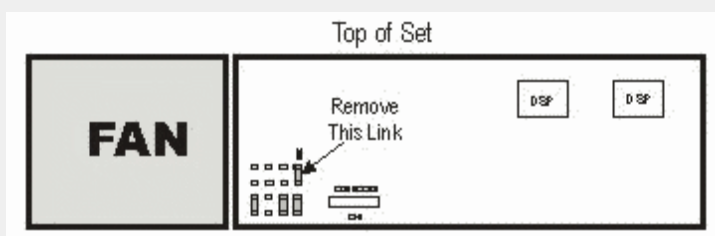

This modification is read 4222 times.

[top of page](#)

04-03-2001

(TS-2000) TS-2000 modification information (TX and RX)

Author: - modifying@hotmail.com.MODIFICATION.NET

I got the modification information on the TS-2000 from reliable sources recently. The info. seems to be correct. My TS-2000 (K-type) worked.

1. Remove the top and bottom cover.
2. Loosen the 4 screws that tighten the front panel.
3. Pull the front panel forward, holding the upper part.
4. You will see a fan on the left.
5. At the bottom right of the fan, there are jumpers.



- Remove R52 to expand the RX frequency.
- Remove R53 to expand the TX frequency.
- Remove R54 to expand the features.
(Cross-band Repeat, SkyCommand, External Remote and etc.)

R52 and R54 have been already removed on my transceiver.

After the modification, it transmits:

1.705 - 30MHz, 49-54MHz, 142-152MHz, 420-450MHz.

* It does not expand too much, though :-)

Oh, I forgot one important thing.

You must perform ALL RESET by pressing and hold [A=B] key when you turn on the transceiver. (You will lose all the memory data).

This modification is read 4871 times.

[top of page](#)

30-05-2001

(TS-2000) Sensitivity Kenwood TS-2000

Author: Hans - PA3HGT

Sensitivity Kenwood TS2000 measured with Rohde & Schwartz CMS52

10dB/sinad SSB			12 dB/sinad FM	
freq.	uV	dBm	Uv	dBm
1 Mc	1,127	-106		
1,8 Mc	0,35	-115,9		
3,7 Mc	0,4	-115		
7 Mc	0,39	-115,1		
10 Mc	< 0,045	< -133,9		
14 Mc	0,21	-120,4		
18 Mc	0,113	-125,9		
21 Mc	0,194	-121		
24 Mc	0,126	-120		
28 Mc	0,091	-127,9	0,163	-122,8
50,1 Mc	0,106	-126,5	0,184	-121,5
145 Mc	0,093	-127,6	0,19	-121,4
430 Mc	0,07	-130	0,14	-123,6
440 Mc	0,082	-128,7	0,146	-123,7

The valeus are measured with the pre-amp on .

73 , Hans , PA3HGT

This modification is read 4057 times.

[top of page](#)

12-07-2001

(TS-2000) Firmware upgrade for TS-2000

Firmware upgrade for [TS-2000](#).

This modification is read 4304 times.

[top of page](#)

01-01-2002

(TS-2000) ARCP-2000 windows CAT software for Kenwoods TS-2000

Author: Kenwood

Notice

Support for customers using ARCP-2000 Radio Control Program.

December 5, 2001

We've updated ARCP-2000 Radio Control Program Ver 1.01 to Ver 1.02. We are offering Ver 1.02 as a download to owners of Ver 1.00 and Ver 1.01. This update can be downloaded from below.

ARCP-2000 Radio Control Program Ver 1.01 update to Ver 1.02 details: (December 05, 2001)

1. Resolves the issue where received data is not updated in the terminal window while continually monitoring packet data.
2. Readability of characters within the terminal window has been improved.

ARCP-2000 Radio Control Program Ver 1.00 update to Ver 1.01 details: (March 30, 2001)

1. SUB frequency display direct entry not possible in satellite mode issue resolved.
2. Resolves frequency number adjustment issue in MAIN display and SUB display while in satellite mode.
3. Resolves the issue where in bands that CTRL is not displayed, MODE is not displayed correctly when calling up satellite memory.
4. Resolves the issue where only 7 characters could be entered in the satellite memory channel name. Now up to 8 characters may be entered.

Download

Note: Download is only available to purchasers of the ARCP-2000 Radio Control Program Ver 1.00 and Ver 1.01. Please note that 'Ver 1.00' can also be updated to 'Ver 1.02'. Please note that even if software is downloaded, it cannot be used by non-purchasers.

Installation instructions:

1. Execute downloaded file and extract the ARCP-2000 installation program into a designated folder.
2. In the previously designated folder, a folder labeled Arcp2000 will be created. There you will find a folder labeled "disk1". Execute the Setup.exe file within the "disk1" folder to begin installation.
3. Once installation begins, follow the instructions to continue with installation.

Latest update: [ARCP-2000 Ver 1.02](#): Arcp102.exe 2.4MB. [Mirror](#)

This modification is read 2361 times.

[top of page](#)

19-07-1998

(TS-2400) TS-2400 out-of-band mod

Locate the rx unit.
Cut the diodes D32 and D33 located inside the DTMF ic.
Is this simple or what?!

This modification is read 599 times.

[top of page](#)

19-07-1998

(TS-2400) TR-2400 Unwanted Noise: Tone or burst at TX

2-13-80

For complaints of a tone burst type noise, or simply a noise, at initial key down, suspect either a broken loose component, or incorrect valued component on the RX TX unit.

On the RX TX unit, Q16 emitter, check C82, a 33 uf tantalum cap for broken connection.

If you find a 22 uf cap at C82 replace it with a 33 uf cap.

This modification is read 465 times.

[top of page](#)

19-07-1998

(TS-2400) TR-2400 Display or Keyboard trouble

2-20-80

Display

An intermittent or blank digit may be caused by either a broken lead, or intermittently shorting lead on the PLL unit.

On the PLL unit, look in the area of Q12, the touchtone generator. Between Q12 and the board edge locate the D1-D4 lines. Inspect this area for either an open (Broken) lead, or shorted (pinched) lead. Repair as necessary, and check lead dress before reassembly.

Keyboard

An intermittent or inoperative keyboard row or column may be caused by a torn or pinched lead, or a cracked diode.

Again, in the area of Q12, inspect the "T" and "Y" lines for shorts or open connections, and inspect diodes D19-D26 for physical breakage.

This modification is read 485 times.

[top of page](#)

19-07-1998

(TS-2400) TR-2400 RX low, INtermittent, or distorted

2-20-80

For any of the above complaints, suspect a broken loose component in the RX IF or audio output circuit on the RX TX unit. Simply pull up on the leads and resolder.

Adjacent to Q9, the audio output IC, find C49, a 1uf cap. If broken loose from the board, audio output may be down, while current consumption may be up from the normal 30mA to about 100mA due to the audio output amp oscillating.

Adjacent to L10, the discriminator, locate C33, a .033uf cap. If this component is broken loose, audio output may be up approximately 6 dB with excessive high frequency audio response.

This modification is read 469 times.

[top of page](#)

19-07-1998

(TS-430) TS-430S Noise blanker improvements

Author: Trio-Kenwood Communication, inc.

Service Bulletin no. 887 (17-10-1984)

Some operators have indicated a desire to have their TS-430S noise blanker operate similar to the noise blankers in the TS-120S/130S series. By performing the following modification the operator will be able to increase the effectiveness of the TS-430S Noise Blanker circuit.

Procedure

On the RF unit (X44-1510-xx) change the following components.

R80 change to a 100 Kohm $\frac{1}{4}$ Watt resistor (RD14CB2E104J)

R81 change to a 56 Kohm $\frac{1}{4}$ Watt resistor (RD14CB2E563J)

C125 change to a 560pF 25V disc capacitor (CK45BIH561K)

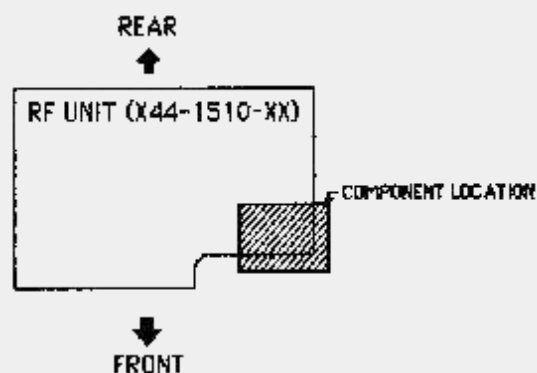

This is an optional change and may not be performed in-warranty.

No realignment is required.

This modification is read 1472 times.

[top of page](#)

19-07-1998

(TS-430) Kenwood ts-430 AGC mod

The type of speech processor circuit used in the ts-430 is an agc (automatic gain control) driven audio frequency amplifier. By decreasing the time constant substantially, the speech processing effect will be improved.

The modification is very simple.

Replace capacitor c104 4.5 uf on the if board by a smaller value of 0.47 uf.

To Modify This Capacitor

1. Remove the if board as indicated for the cw filter installation.
2. Remove c104 from the board.
3. Mount a 0.47 uf capacitor on the board.
4. Mount the if board as indicated by cw filter installation.
5. You are now fully operational again.

6. Adjust the mic gain without the processor until normal alc deviation.
7. Switch the processor on and adjust vr7 near c104 until normal ALC deviation. (do not alter the mic gain at this time)
8. Enjoy the speech processor improvement.

This modification is read 1482 times.

[top of page](#)

19-07-1998

(TS-430) Transmit enable for mars/cap frq for the TS-430S

For MARS and CAP transmit capability, a minor change is required:

1. Unplug the DC power cable.
2. Remove the top and bottom covers of the set.
3. Locate the RF unit connector 10. Diode D39 is near the connector (labeled D39 on the circuit board). Take a small pair of diagonal cutters and clip the lead at the top of the bend.
4. Locate IC-2 on the Control Unit, under the IF unit. Resistor R148 is near IC-2, clip the resistor lead.
5. This completes the modification. Reassemble the unit, being careful not to pinch any leads.

This modification is read 1629 times.

[top of page](#)

19-07-1998

(TS-430) Mods for the kenwood TS430S for amtor

The mods are as follows:-

On the I.F.board change C-164 from 0.22mfd to 10nfd..50v change C-60 from 10mfd to 4.7mfd. 16v....

Parallel a 150kohm resistor across R.109 using a small switch or by whatever means you can design to switch this resistor in and out.

In for arq and out for all other modes. some people use the send/rec switch, others have used the noise blanker switch. I have used a small mini switch which i have mounted in place of the left front rubber foot.

It will probaly help to cut diode d-50 on the i.f.board. If you use a 500hz filter in the cwn or ssbn position then parallel a 10mfd capacitor across C-10 or C-8. add a 10mfd capacitor across C-161.(actually i found that these last two were not necessary in my 430S.)

You will find it best to take the audio from in front of the volume control, but those people using audio from the speaker socket seem to get ok results. Really you can get away with just the first two mods, change C-60 and C-164. this originally came from VK2AGE. 73s de larry in ravenshoe.

This modification is read 1374 times.

[top of page](#)

19-07-1998

(TS-430) TS430 power fault - ANSWERS

Follows my original posting and answers.

>As you read in the subject I have some sporadic but very annoying troubles
>with my 1988 Kenwood TS430s. This is what happens to my gear (and the same
>occurs to the rig of a friend of mine):

>

>Approx. every 3-4 hours of CW operation (while working without any problem)
>the power output drops down to a few watt (tipically duringa pileup and when
>the dx sent 'ik3huk 599...'). During this power-loss the ALC level is low
>(regularly).

>To have back the full power I have to do the following:

>-Turn CARRIER knob fully clockwise (full power position - ALC doesn't move)

>-Key down for several seconds (very loooooong time when in pileup)

>

>I sent the radio to a laboratory for repair (and friend of mine did the same)
>but they're not able to reproduce the power-fault when the radio is on their
>table. They cleaned up all the relais, but the RTX is still loosing power.

This sounds suspiciously like a problem I had with my 430 on voice. It would behave quite similarly, losing power and becoming distorted on an occasional basis. There was a well reported problem with early 430's where the finals were riveted, but not soldered, and the rivets could eventually develop a high electical resistance, with ensuing power problems. This was diagnosed and corrected by

Kenwood early, so I doubt it would be a problem in a unit manufactured as late as yours. (I bought mine in late 1984, and it already had a modified PA -- believe me, I checked!)

My problem turned out to be a marginal connection in the internal switch on the XVTR jack on the back of the rig. This is the connector with 8 pins. The switch is integral to the connector and works when the plug is inserted. The fix was to insert and remove the plug in the jack several times. Since I have done this, my 430 has never shown this symptom again.

I wish I could claim to have deduced this myself, but it was pointed out to me by a friend who read it in a snippet from someone in QST. To whoever took the time to send in that suggestion, I am eternally grateful. Hope this solves your problem, too.

--

Rob Stampfli rob@colnet.cmhnet.org The neat thing about standards:
614-864-9377 HAM RADIO: kd8wk@n8jyv.oh There are so many to choose from.

To all Kenwood users:

*The 430 has a corresponding problem to the older rigs:
specifically the 520(S), 820(S), 530S, and 830S rigs....*

Power drops while running... if this occurs, tighten the screws on the driver board and IF board.

Had this happen to me and friends a few times...also watch out for the coax connector on the back...they get loose too...no lock washer on the back.

73,
Tom
wb9rxj@uiuc.edu

*Diego,
I had a similar problem with a 430. Mine was intermittent. Finally one cold day [0c] it became permanent. I traced my problem to an open via connection on one of the final transistor bases. This resulted in that device not getting a dc return to ground. I re-soldered the via to my success!
I found it by checking dc bias on each final transistor and found one being different in voltage reading.*

Good luck,
regards
George Hawkins

Here is a solution I heard of for a problem like yours. Perhaps it will be of use to you. Luckily, I have not had any problems with my TS430S. I'm very pleased with it.

Hope this is of use to you.

73 es GL.... Mark KG7JL

KD7EV advises intermittent power output problems on his '430 was cured by installing a more conventional nut on the rear panel UHF style antenna connector. Apparently a faulty ground connection at this point caused a change in the VSWR which affected the sensing circuit and thus reducing the RF output power.

Guarda che io ho lo stesso problema con un ICOM IC-745. Ogni tanto la c'e' una protezione che va in funzione e la potenza va giu'. Nel caso mio probabilmente c'e' un problema di corrente di fuga da compensare opportunamente, ma per te potresti provare a vedere se con una semplice vantola puoi risolvere il caso. Infine, tanto per confermare che per me i diavoletti che muovono gli elettronici esistono, il problema c'e' solo di estate, quando la temperatura esterna e' sopra i 20 gradi (... qui in Olanda). Faccio notare che dentro casa la temperatura e' circa la stessa.

Saluti

IOWTD-PA3FWP
Stefano

(In this article Stefano IOWTD told that he had a similar problem on his IC745 and suggested to put a blower on the radio to solve it out. 'His' power fault happened only on summer. (mine in winter too !!) ik3huk)

19-07-1998

(TS-430) TS-430S Intermittent PLL Unlock in FM/AM

Author: Trio-Kenwood Communication, inc.

Service Bulletin no. 888 (17-10-1984)

Some owners of the TS-430S have reported intermittent loss of transmit and Receive when operating in the FM or AM modes, along with a loss of the digital display.

The cause of this may be due to a loss of the FM/AM Heterodyne Oscillator signal. Replacing the components listed below will correct most instances of this failure.

Procedure:

ON the Control Unit (X53-1290-XX) change R131 to a 22 K ohm 1/4 watt carbon resistor, and change C144 to a 3 pF 25v Disc ceramic capacitor.

Time required for this modification is 30 minutes.

No realignment is required.

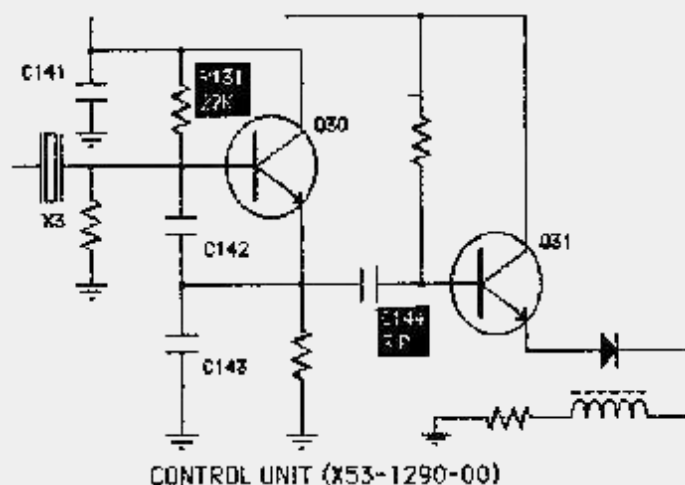

This modification is read 1298 times.

[top of page](#)

19-07-1998

(TS-430) TS-430S PLL Unlock at High Temperatures (Revision)

Author: Trio-Kenwood Communication, inc.

Service Bulletin no. 895 (14-9-1985)

This service bulletin supercedes bulletin 891, which concerned low input level to IC-16 as the radio warmed up. This bulletin incorporates information contained in Bulletin 891 plus additional information.

PROCEDURE:

On the Control Unit (X53-1290-XX)

Check transistor Q8. If it is not a 2SC1815Y change it to this type (Serial numbers 408XXXX-509XXXX).

For serial numbers before 408XXXX change R29 to 820 ohms and C41 to 100 pF.

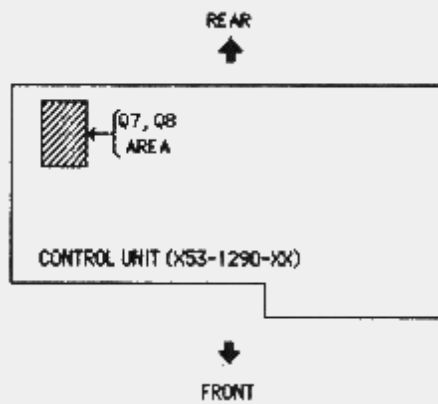

In addition to the changes listed above check for the following signals:
(You must check these at a dial frequency of exactly 14.000.000 MHz)

- TP-1 6.0v (L18 adjusts)
- TP-2 70 MHz
- TP-3 45.3 MHz
- TP-4 6.35v (L10 adjusts)

Time required for this modification is 1 hour or less.

This modification is read 1267 times.

[top of page](#)

19-07-1998

(TS-430) TS-430 extended coverage. Include 0-150 KHz

Author: Wim Beekman

Date: 25-Oct-1988

This modification is to include the receiving range from the TS430 from 0-150 kHz.

Connect a resistor from 1K from IC1 pin 14 to ground in the PLL Unit.

(Pin 14 from IC1 goes to the base of a transistor.)

The best way to do this, is by soldering the resistor at the solder side of the PLL Unit PCB.

This modification is read 1686 times.

[top of page](#)

19-07-1998

(TS-430) TS-430S Reset the microprocessor

For those of you wanting to know how to reset the microprocessor in the TS-430S, here's what it looks like in the service manual:

- 1) FUNCTION SW:A
POWER SW:OFF
Set the POWER SW ON
while depressing the A=B
key. Then release the
A=B key.

Hope this helps someone...

This modification is read 1456 times.

[top of page](#)

26-01-2000

(TS-430) Kenwood TS-430S, no display, no RX/TX with certain modes

Author: Colin Robertson - R.Robertson@ru.ac.za.MODIFICATION.NET

I recently acquired a Kenwood TS-430 with an intermittent fault. The rig would occasionally perform normally but the rest of the time the display and RX would be dead only in the LSB, USB and CW modes. The rig would also not transmit in all modes.

The number of factory "add-on" components found under the PC boards on the rig was a real surprise. The Control and IF boards were first checked for dry joints and several were found, but the fault persisted. All switching circuits appeared to check out fine. After searching the Web for assistance, a mod described in a Kenwood Bulletin for a similar display problem was tried without success. A change in our hot summer weather seemed to indicate the problem was temperature related as the rig worked normally for longer periods under colder conditions. Freeze spray was then tried on all accessible components on the Control and IF Unit boards. No joy!

A QSO with Roger ZS1J, who used to run a ham radio outlet in Natal for several years, had him recalling a similar problem he had encountered some years ago on two TS430's brought in for repair. The culprit in both cases turned out to be leaking LED's on the mode selector switch indicators. He suggested this area be check out.

Removal of plug 13 from the Control Unit board (X53-1290-00) proved Roger correct and brought the rig back to life. There was a very low leakage on the LSB, USB and CW indicator LED's. Exact replacement LED's for D3- D7 were not obtainable locally, so to get around this, 1N4004 diodes were installed in series with the 5 leads on plug 13. The diodes were soldered directly onto the pins in plug 13 (with cathodes facing away from the plug side), and the plug reconnected to the board. The rig is now fully functional again.

It's incredible that the same LED's should fail in three different rigs! Obviously just a bad batch of components used! Maybe this mod can restore a dead TS-430 that someone has given up on.

Colin Robertson
ZS2CR
East London, South Africa
25 January 2000

Packet: ZS2CR @ ZS0ELD
e-Mail: R. Robertson@ru.ac.za

This modification is read 1371 times.

[top of page](#)

23-03-2000

(TS-430) No signal on the meter

Author: Mike WP4COQ - corsino@attglobal.net.MODIFICATION.NET

I have a Kenwood TS430 that was transmitting and receiving fine except that the signal meter was not showing any signal on the AM,CW,LSB,USB.

I open the radio and found that the VR3 pot that is on the X48-1370-00 board was defective, i just replaced the pot with a new one and it start to receive the signals again.

This modification is read 1302 times.

[top of page](#)

09-04-2000

(TS-430) TS-430S 500KHz Hetrodyne

Author: Trio-Kenwood Communication, inc.

Service Bulletin no. 865 (23-3-1983)

Some users of the TS-430S have reported a hetrodyne signal at the 500KHz point on the band. This tone may be reduced or eliminated by the following procedure.

Parts required

Qty	Description	Kenwood parts number
1	.001 µF disc cap.	CC45B1H102K
1	220 pF disc cap.	CC45SL1H221J
1	470 µH coil	L40-4711-13

Procedure

1. Remove top and bottom covers.
2. Turn radio bottom up and locate PLL unit (X50-1910-00).
3. Remove the six (6) screws securing the PLL unit to the chassis and fold the unit over, to allow access to the foil side of the circuit board.
4. Remove the jumper wire that is installed between TP-1 and C6. Install the parallel circuit consisting of the 220 pF capacitor and the 470 μ H coil in its place. See figure 2.
5. Install the .001 μ F capacitor as shown in figure 2.
6. Reinstall the PLL unit and replace the top and bottom covers.
7. No alignment is required.

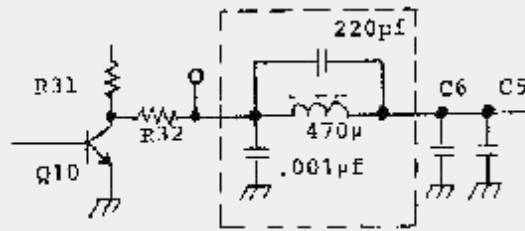

Figure 1

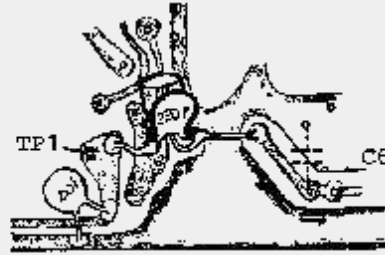

Figure 2

Note: This change may be performed at the owners option and may not be performed in-warranty.

This modification is read 1278 times.

[top of page](#)

09-04-2000

(TS-430) TS-430 Notch Control

Author: Trio-Kenwood Communication, inc.

Service Bulletin no. 882 (7-11-1983)

Notch/Squelch control (VR5) may be replaced with part number R24-9403-15, to allow greater flexibility in adjustment. As can be seen from the chart below, the curve is smoother on the high frequency side (1 KHz to 2.7 KHz), making tuning easier. VR5 is located on Switch unit (X41-1470-00).

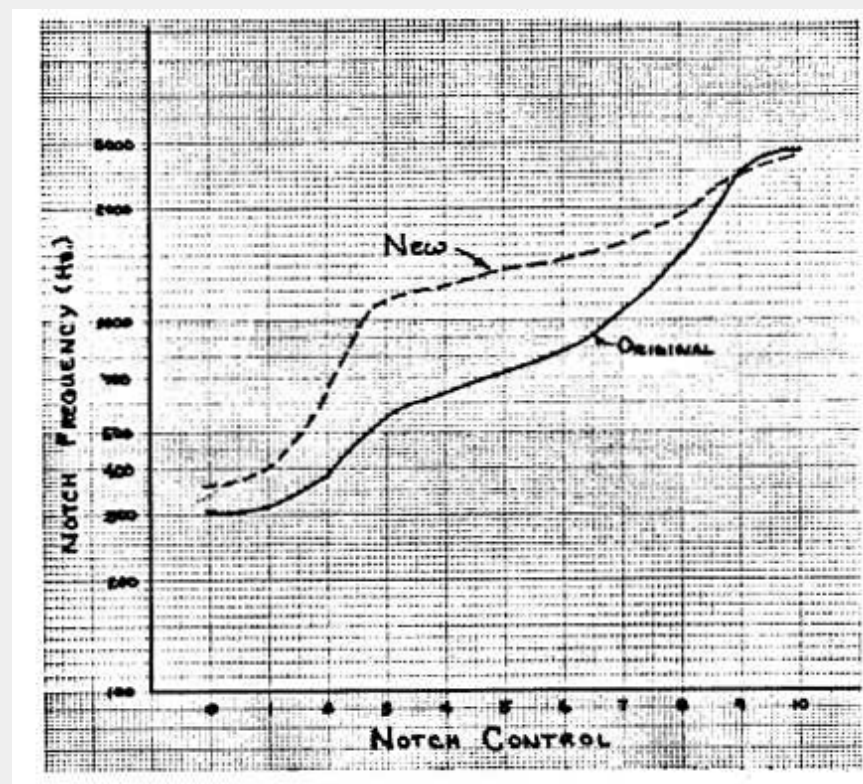

This modification is read 1349 times.

[top of page](#)

Author: Trio-Kenwood Communication, inc.

Service Bulletin no. 883 (8-12-1983)

This procedure will allow selection of the Wide or the Narrow filter for AM.

Parts list

Qty	Description	Circuit designation
2	2SA1115(E) Transistor	Q401, Q402
4	1S1555 Diode	D401-D404
1	4.7 Kohm 1/8 Watt	R405
2	22 Kohm 1/8 Watt	R403, R404
2	47 Kohm 1/8 Watt	R401, R402
	Insulated hookup wire ½28 gauge or larger	
1	Short jumper	

Modification procedure:

Caution: This modification requires advance soldering and printed circuit board modification techniques, and should only be performed by experienced kit builders and or technicians. If you are at all unsure of your ability to install this modification after reading these instructions, please have someone with more experience perform the modification for you.

1. Remove the power connector from the radio.
2. Using a #2 Philips screwdriver, remove the top cover (8 screws). Be careful of the VOX controls, and the speaker lead, which may be unplugged.
3. Loosen the two countersunk side screws and remove the 2 screws securing the IF unit bracket. Swing the bracket up slightly to access and remove the two heat sink screws, Swing the assembly down.
4. Remove 7 screws from the IF unit. Protect the top of the front panel from scratching.
5. Desolder IB1 and discard (use a 45 watt or less iron, and solder wicking).
6. Locate the white jumper wire that is plugged on to the "S" terminal of the IF unit. Desolder the wire from its present location, and reinstall as shown in figure 1.
7. Install a short jumper wire, as shown in figure 1.
8. Cut the foil paths as shown in figure 2. There are five locations that must be cut. CAUTION: Ensure you cut only the traces as shown in the figure. Spend a little extra time to ensure you have correctly identified the trace to cut.
9. Install J401, J402 (may all ready be installed), J403, D403, D404, R403, R404, and R405 as shown in figure 2 (use the shortest lead lengths possible). Check to ensure there are no solder bridges, or splashes on the board.
10. Install Q401, Q402, R401, R402, D401 and D402 as shown on figure 2, again being careful to check for solder bridges, short, etc.
11. Check to see if D82 is installed, as shown in figure 1. If it is not, install it (1S1555). D83 should also be installed on the foil side of the board, as shown in figure 2.
Note: Some unit's have D82 and D83 installed, if so go to step 12.
12. Move the filter select jumper to the "A" pin, as shown in figure 1.
13. On control unit (x53-1290-00), cut the lead of resistor R129.
14. Solder a jumper wire to the metal lead of resistor R129, as shown in figure 5. Connect the other end to IF units connector 18 pin 2 from the foil side of the board as shown in figure 4. The wire may be conveniently routed between the circuit board and the chassis.
15. Install insulating tape below the area of the modification to ensure that no components short out against the case.
16. This completes the modification procedure. The TS-430S will now select either AM Wide or Narrow. Before reassemble, go back through the procedure and check you work, to ensure no errors have been made.

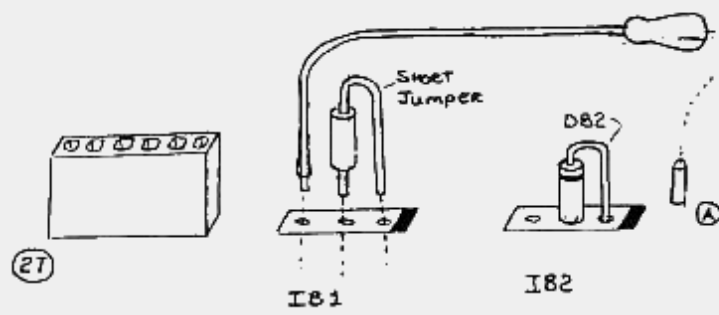

FIGURE 1

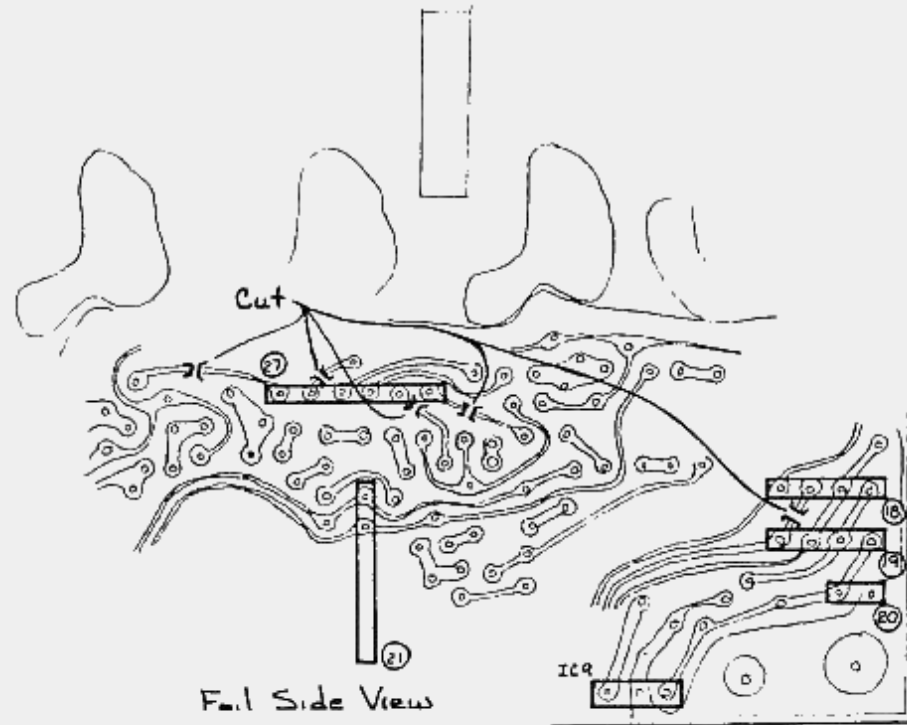

FIGURE 2

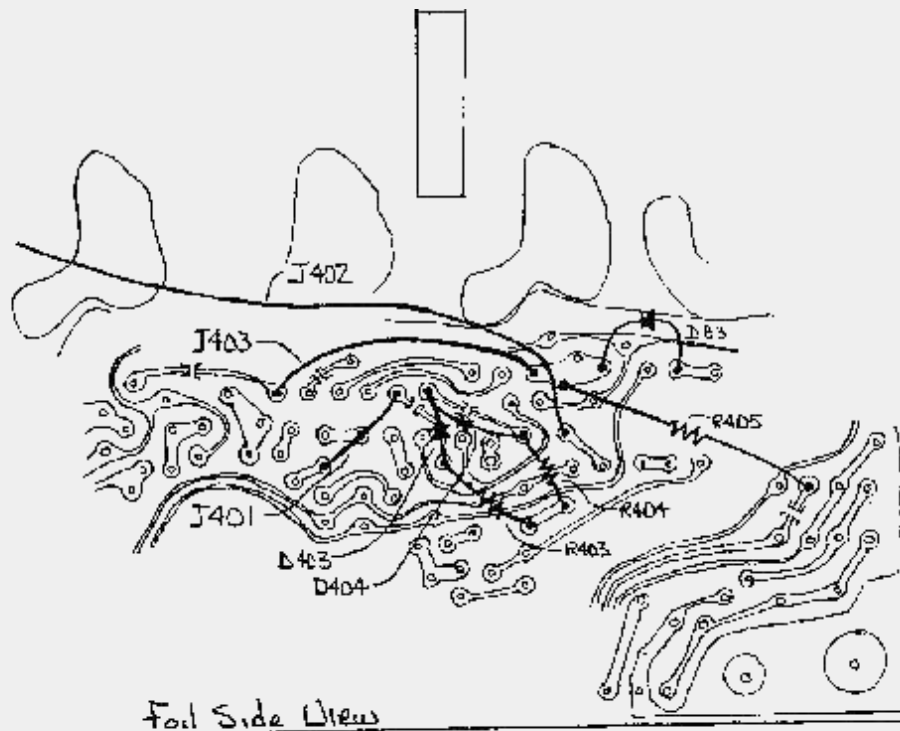
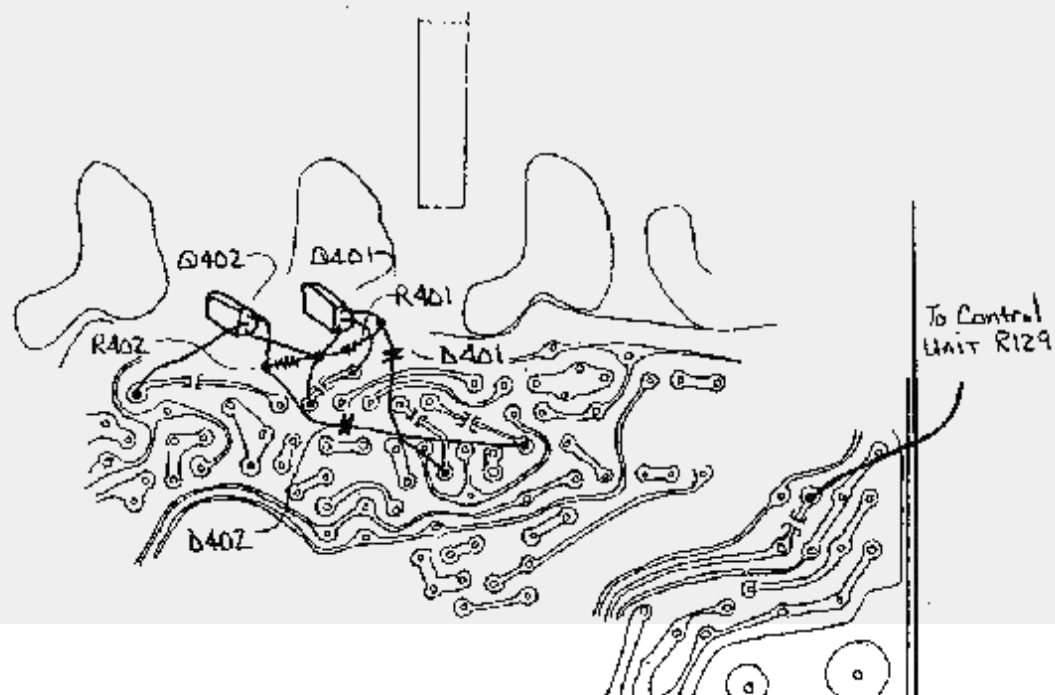

FIGURE 3



Foil Side View



FIGURE 4
Schematic After Modification

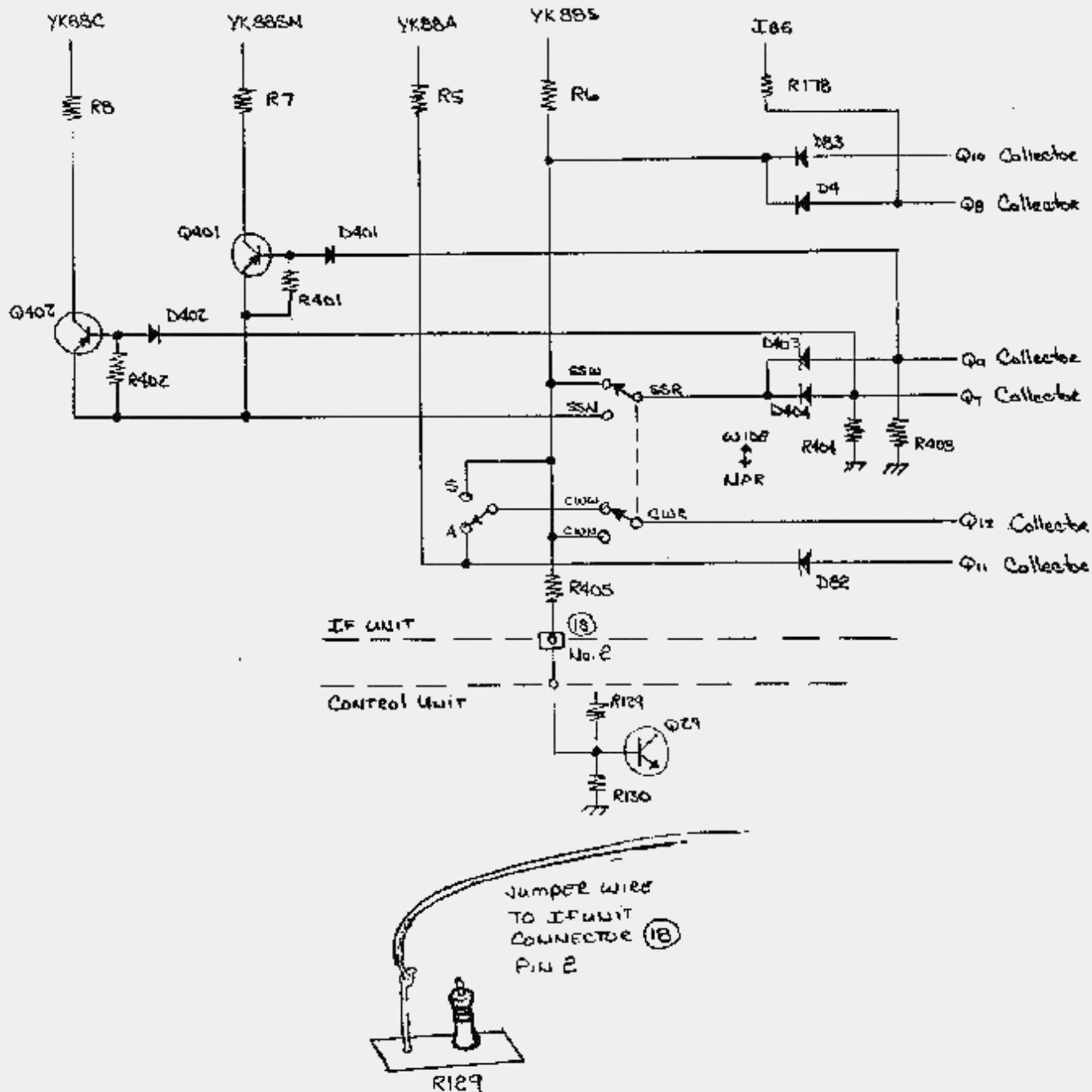

FIGURE 5

Note: This is an optional change and may not be performed in-warranty.

This modification is read 1353 times.

[top of page](#)

09-04-2000

(TS-430) TS-430 receiver internal beat

Author: Trio-Kenwood Communication, inc.

Service Bulletin no. 885 (27-1-1984)

For reports of an internal beat at 20.415 MHz or at 21.526 MHz perform the following modification.

1. On the RF unit (X44-1510-00) add a short jumper wire from the primary ground of transformer T2 to the primary ground of T3 as shown.
2. Add a jumper from the ground of the secondary of T3 to the ground side of capacitor C194, as shown.
3. Solder a jumper from the shield surrounding T1 to the shield surrounding T2, T3 etc. It may be possible to just bridge the two cases together with solder, either way is acceptable.
4. On PLL unit (X50-1910-00) locate the position shown for capacitor C57. This capacitor was not installed at the factory, install a .01 μ F 25V disc ceramic capacitor.

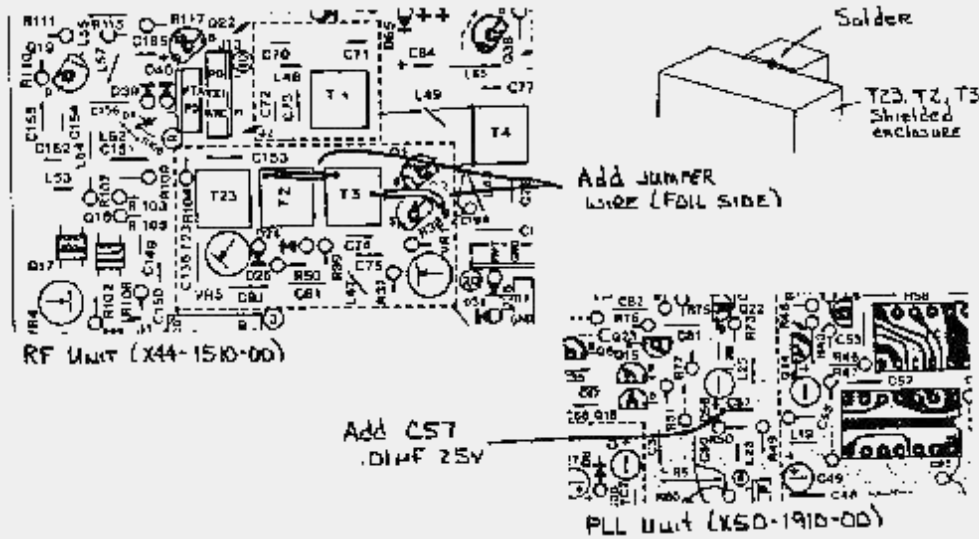

This change is applicable to units prior to serial number 407xxxx.

Time required for this modification is ½ hour or less.

This modification may be performed in-warranty on a case by case basis.

This modification is read 1282 times.

[top of page](#)

15-04-2000

(TS-430) TS-430S Low/intermittent RX

Author: Trio-Kenwood Communication, inc.

Service Bulletin no. 902 (18-10-1985)

Low or intermittent receive on the TS-430S may be caused by a poor contact on one or more of the LPF relays. In most cases the following procedure will correct this problem without having to replace relays. The procedure has two steps; first initial cleaning of the contact by passing a relatively high current thru them (about 500 mA), and then installing a contact maintenance circuit that will apply a relatively low current (about 8 mA) whenever a new band is selected.

Procedure:

I. Initial contact cleaning procedure.

Parts List:

56 ohm 5W ceramic resistor (R92-0622-05)... 2 mA

1. Press and hold the "UP" bandswitch of the TS-430S (ensure the 1 MHz switch is ON).
2. Apply 13.8V DC to the antenna terminal thru a 28 ohm, 10W resistor for approximately 1 minute. This will cycle thru all the relays and burn any oxidation/contamination from the contacts.

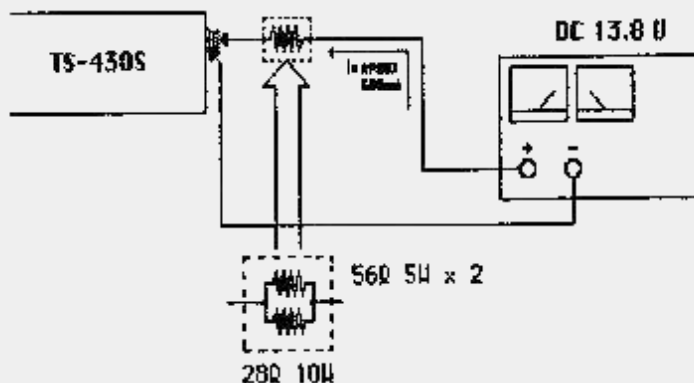

II. Contact maintenance circuit installation.

Part List:

Terminal Strip (E22-0371-05)

C1, C2 (CK45D2H473M) .47 μF 500V

C3 (C91-0117-05) .01 μF 50V

L1 (L33-0259-05) 470 μH

R1 (RD14CB2E102J) 1 Kohm ¼ Watt

Small length of hookup wire 6 inches

1. Disconnect the center lead of the coaxial cable from the antenna terminal.

2. Install the contact maintenance circuit as shown in the accompanying diagrams. Attach the terminal lug strip with one of the filter unit over screws.
3. Solder the 0v lead to the "JP" terminal of the Filter Unit.

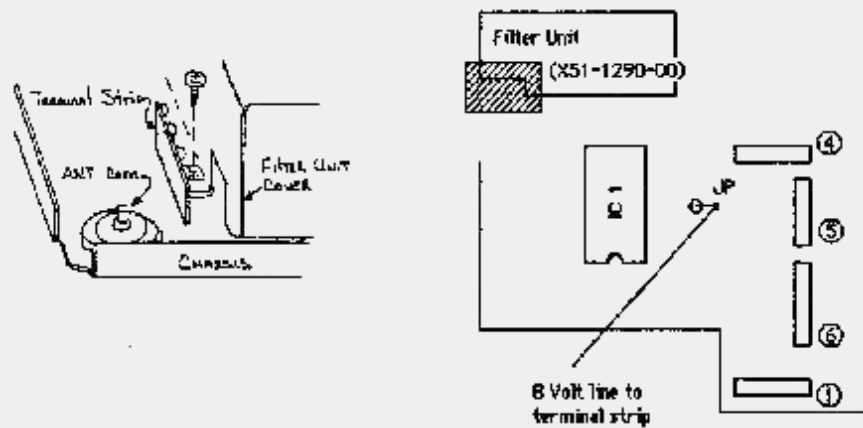
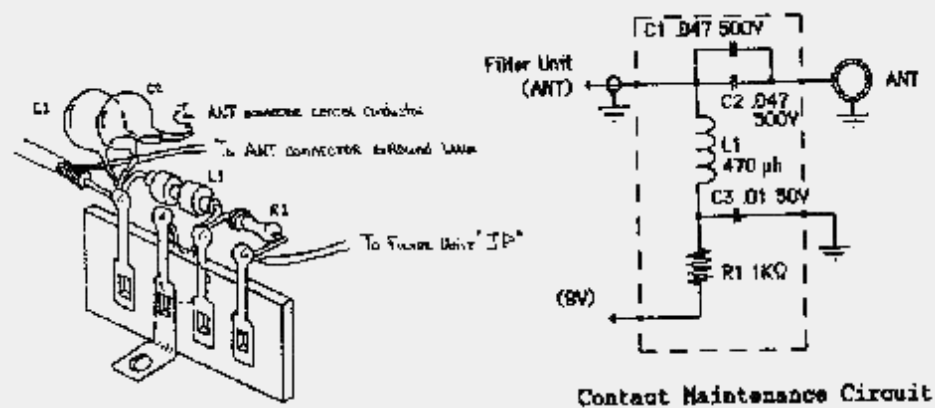

This procedure should may be performed only to those units received for this specific repair symptom. Time required for this procedure is 1 hour or less.

Date: 27-01-2002

User comment

From: [KEN W2GIW](#)

Subject: 56 ohm vs 28 ohm resistors

Mod talks about 28 ohm and 56 ohm resistors. Which one goes between the power supply and the radio?

Date: 25-03-2002

User comment

From: [MC44](#)

Subject: Re: 56 ohm vs 28 ohm resistors

As the diagram states, use either one 10 Watt 28ohm resister or two 5W 56ohm resistors.

Troy

This modification is read 1366 times.

[top of page](#)

24-07-2001

(TS-430) Circuit Improvements for the TS-430S

Author: Richard L. Measures, AG6K

Note: The component locator information is correct with the operator facing the front of the radio.

Problem: Poor noise-blanker [NB] performance on pulse noise. This is caused by an over-enthusiastic NB AGC which causes the NB to shut down prematurely. **Fix:** Change R81 on the RF unit from a 10K Ohm to a 24 -30K Ohm. R81 is near the front of the board between connectors #7 and #16.

Problem: Lack the transmit capability on non-amateur frequencies. **Fix:** On the RF Unit , remove connector #10 and remove pins #2 and #3 by pressing the release tabs on the side of the connector with a small jeweler's screwdriver and sliding the pins in the direction of their wires. The loose pins should be covered with insulating tubing so they won't short out to the other circuits.

Problem: 9.5db of treble roll-off at 2800Hz in the receive audio. This makes the audio sound muffled and hard to understand. **Fix:** On the IF Unit, between L4 and connector #24, change C42 from a .033µF to a .003µF - .0047 µF non-inductive capacitor. A disc ceramic capacitor or a non-inductive Mylar unit will do the job. **Note:** To prevent operator fatigue, after this modification is made, the RF Gain control should not be operated any higher than is necessary to just begin to hear the sky-noise on the particular band being used. In this way, weak stations can still be heard, but the background sky-noise will not become annoying.

Problem: Lack of crispness in transmit audio. This can be due to the carrier oscillators periodically needing adjustment as the components in the radio age. The adjustment is made on the Control Unit. Two, small ceramic trimmer capacitors are located next to two crystals in the lower left hand corner of the board. The designators are TC3 and TC4. The capacitor nearest the front of the radio adjusts LSB. The other capacitor TC4, adjusts USB. With the IF shift on "0", these adjustments can be set "by ear" while listening to a broadcast station tuned to zero -beat. The carrier oscillators can also be adjusted by transmitting into a wattmeter/dummy load while feeding about a milli-volt of audio into the microphone jack. As the audio frequency varies, the power output will fall off at the edges of the crystal filter passband, or "window". Set the audio frequency to 1000Hz and adjust the microphone gain to produce 40 watts output. Lower the frequency to about 300Hz. Adjust the carrier oscillator to produce 10 watts. The rest of the problem is caused by a 4.5db roll-off at 2800Hz in the microphone amplifier. **Fix:** Change C96 on the IF Unit, next to connector #10, from .015 μ F to a .001 μ F [1000pF/1nF] disc-ceramic capacitor.

Problem: Noisy Transmit/Receive Relay. Cutting R28 { 2.2k Ohm, 1/4 W } on the X41-1470 Switch Unit, behind the ATTN Switch, will reduce the noise to less than 1/2 by stopping the ATTN Relay from activating on transmit. In late serial number 'TS-430S', it is easier to cut the only white wire that goes to the Switch Unit than to cut R28.

Problem: Intermittent ALC during transmit and/or intermittent reduction or loss of power output. The power output can sometimes be restored to normal by turning up the microphone gain or by dropping the radio a few inches. Signal reports of intermittent transmit audio distortion are normal.

Note: If the radio continues to be operated after displaying these symptoms, the eventual result is often catastrophic failure of Q2, Q3 [RF driver-transistors], and Q7 [bias-transistor] on the 100W Final Unit.

Why: This problem is caused by repeated thermal expansion and contraction of the cheap, phenolic printed circuit board [PCB] which eventually breaks the two, plated-through the circuit board connections between the output of the 10W driver stage and the input [base] connections to the 100W RF final transistors, Q4 and Q5. When the break occurs, the RF from the drivers does not reach the input [bases] of the final transistors, so there is no load on the driver output transformer, T2. Without a load on its secondary, the peak RF voltage across the primary of T2 runs wild and breaks down the collectors of the driver transistors. When the driver transistors fail and short, they destroy the bias transistor, Q7, as well. Changing these components is an unpleasant and uncheap job. Worse than that, the same components will most likely fail again unless the real problem on the PCB is taken care of. **Fix:** On the component side of the 100W Final Unit circuit board, install a jumper wire between the (outer) end of R12 that is nearest to the base of Q4 and the base lead of Q4. Install a jumper wire between the (outer) end of R13 that is nearest to the base of Q5 and the base lead of Q5. These two jumper wires make sure that the driver RF arrives at the final amplifier transistors, whether or not the plated-through connections are doing their job.

Another method of fixing the problem is to solder Z-wires in the plated through holes. [a Z-wire is a wire that is passed through the board and whose ends are bent in opposite directions so that it will stay in place during soldering]

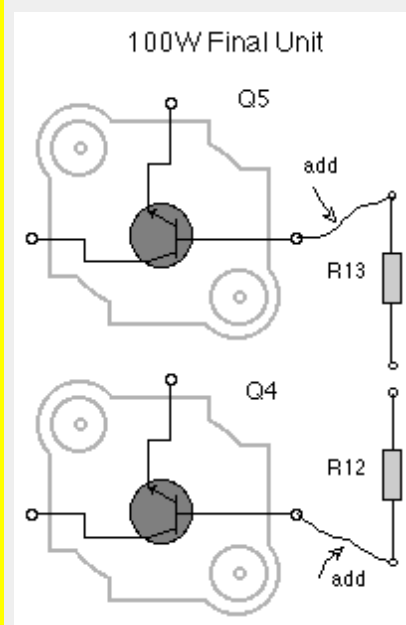

Problem: AGC / S-Meter overshoot. This affects the receive audio, causing it to lose volume for about 2 seconds after switching from transmit to receive when a >S9 signal, is on frequency. When this problem occurs, the S-meter will temporarily zoom up to 30db above the real signal level. Turning the RF Gain control down is no help. **Fix:** Most of the trouble is caused by R32 on the IF Unit. R32 is located behind the CW filter space on the circuit board. R32 should be changed from a 390K Ohm to 2.2M Ohm - 3.0M Ohm. The lesser part of the problem is caused by R40 on the RF unit - which is between connectors #4 and #15. R40 is changed from a 470K Ohm to a 20K Ohm - 47K Ohm.

Problem: Complaints of buckshot or splatter from other operators who are using adjacent frequencies. This problem can be caused by improper bias setting for the driver and the final in the 100W Final Unit. The Service Manual describes a simple method of setting the two bias adjustments. A much more common reason for causing splatter is excessive ALC. Here's why: The TS-430S has a sluggish ALC metering circuit and an ALC characteristic that needlessly delays the ALC attack [throttle-down] time. The ALC meter barely moves when there is already an abundance of ALC activity taking place. So, if the ALC meter indicates a mid-scale / normal amount of ALC, the radio is being overdriven. Under this condition, due to the built-in too-lengthy ALC attack characteristic, the radio will produce power output peaks of 140W at the beginning of loud syllables. These peaks can be observed accurately on an oscilloscope. Most power meters are not capable of observing the <2mS overshoot. 140 watts of PEP output may sound good, but it is beyond the linear output power capabilities of the final transistors. The net result is rotten splatter. To reduce splatter, the microphone gain should be adjusted so that the ALC-meter barely moves on loud voice peaks. For those operators who like to see the meter jump whilst talking into the microphone, operating the radio correctly is going to cause emotional stress. This problem can be alleviated by increasing the sensitivity, full clockwise, of the ALC meter adjustment, VR11, on the IF Unit. This will make the ALC meter indication quite lively and some operators quite happy. VR11, which is located on the right/front of the board, is very close to, and easy to

confuse with, VR12 which should not be adjusted except per the directions in the Service Manual.

This modification is read 1628 times.

[top of page](#)

26-07-2001

(TS-430) Some repair hints for TS-430

Author: Chris, HB9BJL - hb9bjl@uska.ch.MODIFICATION.NET

1. **no display, no TX/RX with certain modes**

I read the article of Colin Robertson and I would like to tell you that my TS 430 S had exactly the same problem a few years ago soon after purchase. The solution was to replace the excessively leaking Diodes D3 - D7 but that meant to remove the front pane. It took the Kenwood dealer quite a long time to repair it. Meanwhile the exact replacement might not be available anymore. Therefore it might be a good idea indeed to add the diodes in series as you have described.

2. **Low/intermittent RX**

After a few years of usage I faced the Low / intermittent RX problem. The problem were the Fujitsu print relays on the LPF board. I got around this by replacing all of them. Lucky enough I was able to find them with a major electronics parts distributor who has Fujitsu relays in store.

73s from Switzerland

Chris, HB9BJL

hb9bjl@uska.ch.MODIFICATION.NET

This modification is read 1691 times.

[top of page](#)

05-10-2001

(TS-430) General coverage in transmission for the Kenwood TS-430S

1. On the the bottom board of the transceicer find the RF-UNIT (X44-1510-11).
2. Near the two plugs numbered 9 and 10 , you will see two diodes called D39 and D40.
3. Simply cut the two diodes D39 and D40 on the RF-UNIT.

Date: 12-02-2002

User comment

From: [fy5ls](#)

Subject: ts 430s general coverage modification

cutting the 2 diodes d39 d40 does not do anything; removing the plug n°10 does the same : nothing do you have an other trick ?

73

marc fy5ls

This modification is read 1681 times.

[top of page](#)

16-12-2001

(TS-430) TS430s low RX

Author: Beavan Gwilt - gwilt@telkomsa.net.MODIFICATION.NET

After 17 years service my TS430s also exhibited the problem of low RX over frequency ranges which coincided with the ranges of the LPF's on the filter unit.

Fix:

1. Remove filter board, and remove plastic covers of the relays by gently prizing with a small sharp-edged screwdriver.

2. Cut a narrow strip of photo-copy paper, insert it between the contacts, and apply pressure to the contacts as you withdraw the paper. Paper is relatively abrasive, and this will clean the contacts.
3. I found that that some of the contacts hardly made contact before the relay armature was fully home. Fixed by bending the contact finger so that the contacts made before the armature was home - this ensures adequate contact pressure.

This modification is read 1029 times.

[top of page](#)

19-07-1998

(TS-440) TS-440S Digital Audio Modification

NOTICE:

Please be very careful with your transceivers, and we accept no responsibility for any damage that may be incurred, and this modification may, and probably would be cause for any WARRANTY to be DISCONTINUED.

This Modification allows for the Kenwood TS-440s transceiver to have the data audio on PIN 11 of the 13 pin DIN connector ACC JACK 2. Later models may or maynot have a correction for this, but my PK-232, or for that fact NONE of my TNC's would drive the audio to the PIN 11 of ACC JACK 2. Encountering this problem, and having another H.F. transceiver I have been using the REMOTE connector, and using an audio input to the AFSK IN RCA type connector. This would allow me to use the same cable with my TS-180s also. Anyway this modification moves the wire's from the AFSK IN to the ACC 2 connector. This should only take about 20 to 30 minutes to preform this change, and most of the time is used up with the removal, and replacement of the THREE covers of the transceivers cabinet.

The circuit boards to work with, are called:

DISPLAY UNIT (X54-1870-00) (C/4) This has the ACC 2 JACK.

SWITCH UNIT (X41-1610-00) (M/14) This has the AFSK INPUT.

The easiest way is to remove these two boards 4 screws hold the ACC 2 JACK, and 2 screws hold the AFSK INPUT board in and they are located at the rear of the transceiver. If you are interested in following the SCHEMATIC in your manual, the leads you will be working with are ANI, and GROUND which is the PURPLE LEADS, and the FSI lead and GROUND, which are the GREEN leads.

The problem is that when kenwood designed this rig, they brought the DATA INPUT(ANI) from the ACC2 JACK to connector J25 of the IF UNIT.

This coming in after the Processor, and Microphone Amplifier does not allow sufficient amplification of the signal, thus very low, or no audio at all. What this modification does is swap at the rear of the RIG the FSI, and ANI signals, Which also could be done on the IF UNIT board, and for some may actually be easier. In my case the leads were just a bit too short to allow this modification to be accomplished on the IF UNIT.

MODIFICATION

1. Be shure to have on a work bench, and NO POWER APPLIED!
2. Remove the TWO BOTTOM covers, One MAIN cover, and the smaller cover to the REAR of the transceiver.
3. Remove the TOP cover.
4. Remove the FOUR screws holding the AUTOMATIC ANTENNA TUNER.
5. Place the transceiver on it's side with the BOTTOM towards you, and the FRONT to your LEFT.
6. Being very careful, remove the antenna tuner and allow it to hang.
7. Remove the TWO SCREWS that HOLD the AFSK INPUT board.
8. Remove the FOUR SCREWS that HOLD the ACC 2 JACK board.
9. Carefully from the inside of the transceiver, pull these TWO boards out.
10. Near the Bottom edge of the ACC 2 JACK board, is a TWO lead connettor, unplug this. The leads should be PURPLE.
11. On the AFSK INPUT board, there is a 6 PIN connector, unplug this. The leads you will be working with are GREEN in color.
12. Note how the PURPLE leads are connected to the connector itself, and remove these two leads by inserting a very small screwdriver into the slot on side, and being very gental, push the leads out one at a time.
13. Now remove the GREEN leads the same manor.
14. Insert the GREEN leads into the 2 PIN connector, the BLAC lead is the GROUND, and the WHITE or perhaps YELLOW is the AUDIO lead.
15. Insert the PURPLE leads into the 6 PIN connector, noting that the smaller lead is the AUDIO lead, and it connects to PIN 2, the other lead, being BLACK goes into PIN 1.
16. Now reassemble in reverse order the BOARDS, and start at STEP 11, and work in reverse to STEP 1.

This modification is read 2423 times.

[top of page](#)

19-07-1998

(TS-440) TS-440 Fan Temperature Modification

I don't know about you, but I don't think solid state equipment needs to run hot enough to fry an egg on. The fan on the 440 is set to come on at 50 deg C. That makes the heatsink hot enough that you can only put your hand on it for about 3 seconds without being in pain.

Looking at the schematic and pondering the situation, I decided that it would be quite easy to change the "trigger" point for fan operation. This mod will do just that and not effect the "high-temp-shutdown" mode that is provided in case the fan dies. Actually, it wouldn't be a bad idea to make the same sort of mod to that circuit too, but let's just do this one for now. I'll put out another bulletin on this if I go into the failsafe circuit.

The fan is controlled by two sensing circuits on the FINAL UNIT. On the schematic, Q9(1/2) is the failsafe trigger that activates the powerdown circuit in case the final reaches 80 deg C. It won't normally do this, even under continuous keydown conditions, unless the fan has failed.

Q9(2/2) is the stage that controls operation of the fan. It is a simple voltage comparator and therefore can be made to trigger wherever you want.

TH1 is a thermistor with a negative coefficient. That is, when the temp rises, the resistance goes down. This pulls the - input to Q9(2/2) lower and lower until it is at or below the 2.26v reference that is present on the + input of the same stage. At that point, the output flips high and turns on Q8, thus turning on the fan. By raising the reference voltage at the + input, the TH1 voltage will fall to the reference voltage sooner and turn on the fan at a cooler temperature. By clipping the top loop of R27 on the final unit (2.2k res. that provides reference voltage) and temporarily inserting a 5k precision multi-turn pot in series with it, I determined that I liked the way it operated with about 800 ohms extra resistance in the circuit.

I then installed an 820 ohm fixed resistor in series with the cut loop. I also put a very small dab of silicon seal between the new "hung" resistor and the ferrite transformer right next to it so that there would be no added strain on the remains of R27. The alternative would be to remove the final unit completely and do the mod the right way, replacing the complete R27 with a 3k resistor. This was a step that I didn't really want to perform on a two week old rig. When you choose your series resistance, remember that the more resistance you add to it, the sooner the fan will turn on. If you go too high, it will be on all the time.

This modification brings the fan on at least 10 deg. earlier. By the way, my only reservation about this mod is the added wear and tear on the fan unit itself. I have been buying parts from Kenwood for about 10 years now and they have always seemed remarkably inexpensive. Ordering a spare fan to have on hand seems like a very reasonable thing to do if you are worried about it.

This modification is read 2135 times.

[top of page](#)

19-07-1998

(TS-440) Possible cure for TS440 showing dots only on display

The most common reason for the the display to show only dots, is that one of the phase locked loops is not locked. So take of the top cover. You will be looking at the IF unit. This board is mounted in a hinged frame. It hinges on two screws near the front pannel sides. So remove the other two screws near the final unit instead and hinge the IF board towards you. You now uncovered the PLL unit.

There are five PLL's on this board. Each one has a pin indicating if its loop is locked or not. So get out a volt meter and set it for 5 volts full scale. Now check pin 2 for each of the following IC's. IC18, IC1, IC4, IC9.

Also check pin 7 of IC17. If all the loops are locked, you would see a steady voltage there in the neighbourhood of 4.7 volts. If any of the loops is not locked, one of these pins has a voltage well below 1 volt.

Note the IC number so you can look up which VCO you may have to tune a bit so it will lock again.

IC18 VCO#5 T20
IC1 VCO#4 T1
IC4 VCO#3 T2
IC9 VCO#2 T9

The above are all located on the PLL board.

The VCO for IC17 is actually one out of four different VCO's selected on the RF board. Which one of these depends on what band is selected.

If you have display dots on all the bands, then you have no problem with the PLL made up with IC17. So you only have to adjust either T1, T2, T9 or T20.

Now here it goes. Make sure you have an alignment tool that isn't too small or too large for the slots in the slugs in the coils (T1, T2, etc.) Also, absolutely don't turn any other coil than the one that belongs to the unlocked PLL. If you do so anyway without a service manual and proper equip- ment, then you are likely stupid.

Only turn the indicated slug. First turn it 1/4 clock wise and see if it is ok now. If not, turn it 1/4 counter clockwise and see if it works. I suggest that you don't try more than one half turn either way. If you think that it needs to go that far, it likely has an other problem.

If the display dot problem only shows up on some but not all band, send me a note and I will see if I can help you.

The correct way would be to use a good voltmeter and follow the service manual for this adjustment. But in most cases, the above will do fine. I don't work for Kwood, I don't have a 440. Just a service manual for one. But I did cure some of the above problems.

19-07-1998**(TS-440) Undocumented feature**

The TS440 is nice. Here's what I've found out about it that isn't in the operation manual (in some random order):

Diode options: There are a bunch of configuration options controlled by clipping or inserting diodes on the back of the control board. You get to it by taking the top and bottom covers off (a bunch of silver screws), loosening the front panel (4 flat-head silver screws, NOT the black ones). Then you have:

diode	controls	in	out (cut)
-----	-----	-----	-----
D65	mode confirmation	Morse	single beep
D66	display resolution	100 Hz	10 Hz
D67	memory protect	none	on
D73	CW shift	800 Hz	400 Hz
D78	WARC 24MHx band tx	disabled	enabled
D79	WARC 18MHz band tx	disabled	enabled
D80	General Coverage tx	disabled	enabled

Self-Test: You can run a rather complete test of the control logic by the built-in "semi-self-test", a series of 56 routines. To run this, turn the unit on whilst holding the AM and T-F SET switches pushed in. It changes to the next test when you turn the VFO knob clockwise. Turn the power OFF to reset the unit.

Test	What it does
----	-----
0	all positions in display light
1	all segments in display dark
2	all positions in display light
3	all segments in display dark
4	one digit lighted (rightmost)
5	next digit lighted
6	next digit lighted
7	next digit lighted
8	next digit lighted
9	next digit lighted
10	next digit lighted
11	next digit lighted
12	next digit lighted
13	next digit lighted
14	next digit lighted
15	next digit lighted
16	next digit lighted (leftmost)
17	beeper sounds
18	beeper silent
19	all mode LEDs ON
20	all mode LEDs OFF
21	receive
22	transmit

The following tests change internal signals. They are most useful if you are trying to trace the circuits controlled by these signals. You'll need a service manual (or at least a schematic) to make real sense of these.

23	Band select - all lines high
24	BAND select - all lines low
25	PD select - all lines high
26	PD select - all lines low
27	ENF select - all lines high
28	ENF select - all lines low
29	ENP select - all lines high
30	ENP select - all lines low
31	RES select - all lines high
32	RES select - all lines low
33	CO select - all lines high
34	CO select - all lines low
35	AX select - all lines high
36	AX select - all lines low

these next tests check the outputs of the 8255 parallel port interfaces, which select several internal functions.

```

37      (IC2) port A all lines high
38      (IC2) port A all lines low
39      (IC2) port B all lines high
40      (IC2) port B all lines low
41      (IC2) port C0-C3 high, C4-C7 low
42      (IC2) port C0-C3 low, C4-C7 high
43      (IC53) port C all lines high
44      (IC53) port C all lines low

```

Following display busy lines and scan lines in the rightmost 9 digits of the display. You will push buttons to cause the digit to change from a 1 to a 0 indicating that the associated button has been pushed.

test	bit8	bit7	bit6	bit5	bit4	bit3	bit2	bit1	bit0
45	LOCK		AT	Mic UP	Mic DN	PTT/AT			VS1
46	(none)								
47	(key scanner)								
48	1	6	V/M			VOICE			
49	2	7	M>V	RIT		A/B			
50	3	8	SCAN	XIT		SPLIT			
51	4	9	M.IN	T-Fset		A=B	dip3	dip4	dip5
52	5	0	CLEAR	1Mhz		dip1	dip2	dip6	dip7
53			ENT	DOWN		UP	dip8	dip9	dip10

(the digits 0-9 are on the front panel keyboard; dip2-dip10 are the segments of S50, the SSB frequency response dipswitch on the rear of the control unit printed circuit board.)

54 not used
55 not used
56 END

This modification is read 2685 times.

[top of page](#)

19-07-1998

(TS-440) Serial interface

The TS440 has a serial ASCII interface option. You have to insert two chips into sockets on the back of the control unit circuit board to take advantage of this. IC54 is an 8251A Uart, and IC55 is a CD4040 divider. These chips are available from Kenwood together with a interface manual, or you can buy them at your local chip shop for about \$6.00 or so. When inserted, the transceiver speaks 4800 baud ascii in/out the 6-pin DIN connector ACC-1 on the rear. The signals are from the 8251, but are inverted in a 74LS04 and RFI filtered before being brought out to the world. An interface box with inverter, RFI filter, power supply, opto-isolator, RS232 level shifters, and power supply is available from Kenwood for about \$49.00, or you can build your own.

(Depending on how much your computer radiates and how sensitive to RF it is, you may only need 5v, +/-12v, a 74LS14, MC1488, and MC1489. If your computer has a TTL level serial port, perhaps all you'll need is the 74LS14. If you're not confident of being able to solve the possible digital/RF interface problems yourself, the \$49 interface is probably a good buy.)

pin	ACC-1 Serial Interface signal
1	signal ground
2	data from transceiver
3	data to transceiver
4	cts to transceiver - computer can throttle output
5	cts to computer - transceiver can throttle input
6	no connection

SSB frequency response dipswitch: located on the back of the control unit, this adjusts the frequency response of the upper and lower sideband modulators to compensate for component variations. Changing it isn't a good idea, since you have to have a two-tone oscillator and have to reset the carrier suppression adjustment if you do. The service manual explains this process; I'm including this here so that people who have been wondering what the dipswitch does won't screw themselves by flipping switches to see what happens.

This modification is read 2216 times.

[top of page](#)

19-07-1998

(TS-440) A few adjustments you should know

A few adjustments you should know about (read the service manual before you tweak wildly on these!):

tweaker	what it does
RF-VR3	FM Microphone Gain
RF-VR6	FM Deviation - set to 4.6KHz on dev meter
IF-VR2	S-meter zero - set to zero with 50 ohm dummy load
IF-VR3	S-meter S9 - set to S9 with 40dbu input 14.175MHz USB
IF-VR4	Squelch threshold - close at 12 o'clock with mode = CW and filter WIDE
IF-VR9	CW side tone level - as you like it
IF-VR10	Beep tone level - as you like it

Someone wanted to know what the difference between the DATA connections on ACC-2 and the AFSK connectors was. On output, none; the AFSK and the DATA out pin on ACC-2 are connected together, and are fed from the high side of the volume control - they are receiver audio BEFORE the cw sidetone, beeper, and voice response unit are mixed in, and should be a constant level independent of the AF gain setting. The AFSK input is different from the DATA IN connection; AFSK and microphone signals both go through the mike preamp and speech processor; the DATA input bypasses both. The MIC GAIN pot does control all three input levels. (as a note, you can tap preamped/processed audio OUT of the DATA IN connection, since it is just a tap on the output of the preamp/processor. This is also the feed into the FM modulator. But NOTE that the MIC GAIN pot doesn't adjust the mic gain on FM - there is a separate tweaker for that.)

This modification is read 2520 times.

[top of page](#)

19-07-1998

(TS-440) TS-440S modification to use antenna tuner

Remove case from rig. Remove (4) screws that holds antenna tuner in place. Next slide antenna tuner out to get to the coax connections. Remove the in coax attached to antenna tuner from FO connector on filter unit (X51-1340-00). Remove coax from out connector on antenna tuner and install in FO CONNECTOR ON FILTER UNIT. Unplug and remove switch unit (X41-1610-00 N-14) from rig.

Remove short wire from antenna connector to PC BOARD. Cut coax on the in connector of antenna tuner in half and connect cut end to switch unit PC BOARD Where short antenna wire was removed and shield to ground. Solder other half of coax to antenna connector and shield to ground, and plug other end into out conector of antenna tuner. Your still have control of antenna tuner with auto and thru switch. It works very well. Maybe someone can use this idea.

This modification is read 2226 times.

[top of page](#)

19-07-1998

(TS-440) TS-440S display calibration

I found there was some shift in the reference oscillator frequency of my TS-440S. This can be noticed and corrected as follows:

1. Remove the top and bottom covers from thd radio.
2. Do not disconnect the speaker cable.
3. Connect the supplied calibration cable between RF Unit and PLL unit, as shown in "Kenwood TS-440S Instruction Manual" on Page 24 in Section 5-8-3.
4. Set VFO A to 10.001.00 MHz LSB and VFO B to 9.999.00 MHz USB.
5. Pushing the A/B function button, you can have different audio signals, if that 36 MHz reference oscillator is miwadjusted.
6. Using a small flat bladed scredriver, adjust trimmer capacitor TC1, near connector 8 of the PLL Unit (the location shown in Instruction Manual in the same section as above) until those audio frequencies from VFO's A and B are equal.
7. Disconnect the calibration cable and reassemble the radio. This procedure can be done by ear with good accuracy without any measuring equipment. WWV is too weak here in Finland to use it as comparative signal for the procedured described in "Instruction Manual", Section 5-8-3.

This modification is read 2070 times.

[top of page](#)

19-07-1998

(TS-440) Connection of the KENWOOD TS440S to a DATA

Connection of the KENWOOD TS440S to a DATA terminal such as a Kantronics KAM using the rear ACC2 13 pin jack.

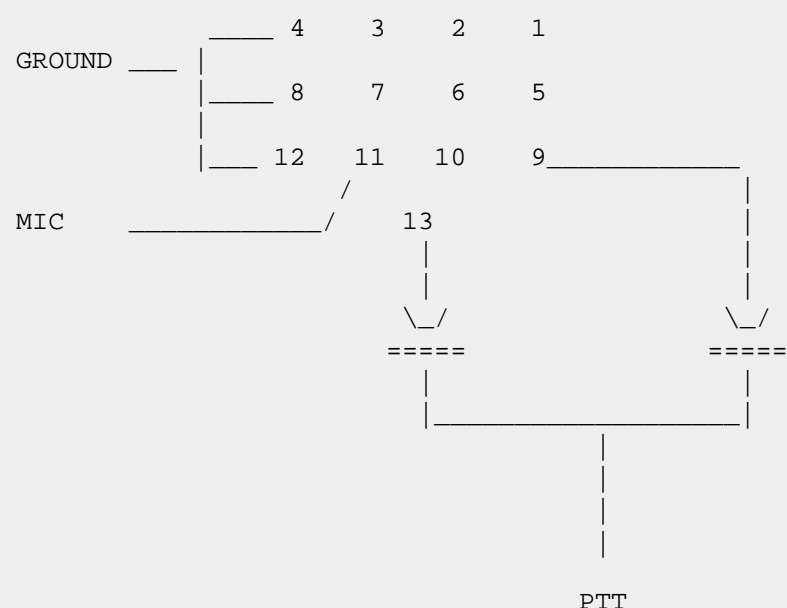

Pins	Application
3	Data output - not used as the level is very low the preferred connection is via the speaker output this also allows fine adjustment of level to enable best decoding. (A switch on the speaker to 'mute' it when required is a good idea.)
4 8 12	Ground - you may have to experiment with these connections to eliminate RF feedback and noise. Here they are all strapped.
9	Mic mute - prevents audio pickup from the mic when earthed. By connecting to the PTT line as shown through a diode automatically MUTES the mic when using data. When the front panel PTT or MIC PTT are used the microphone is 'live'.
13	Standby - PTT which when taken to ground puts the set 'on air'. By connecting through a diode as shown doesn't affect the PTT operation but allows auto mic muting.

The diodes used can be virtually anything, here they are IN4148.

The INPUT audio to pin 11 must be quite a high level. If using a KAM you are certainly going to have to change the HF LEVEL JUMPER in the KAM. The level of the KAM as shipped suites connection to the FRONT PANEL MIC but not the rear connector, you can however correct this with the jumper. People using the PK232 have complained of NO TX AUDIO, I suspect the level is so low that only local minitoring will show a level present.

This modification is read 2076 times.

[top of page](#)

19-07-1998

(TS-440) Kenwood Computer Interface Instructions

These Instructions are TS-440 specific, but the basics also apply to the TS-940, TS-811 and TS-711.

It is possible to save yourself a few dollars and lose nothing in quality by buying the parts to upgrade your Kenwood radio for computer control. Just purchase the parts were you find them and install them using the instructions in the Radio's Manual.

IC 54 is a uPD-8251-AC Serial Communications Interface.
 Commonly called an 8251A (\$1.89 Mail Order)

IC 55 is a TC-4040-BP 12 Stage CMOS Divider.
 Commonly called a 4040 (\$0.69 Mail Order)

The IC-10 Interface Kit from Kenwood Contains ONLY these two parts and less instructions than are in this file. The only thing you are

going to miss, is the \$22+ price tag on the IC-10 Kit.

Signals are TTL levels (NOT RS-232)
Baud rate is 4800 (1200 Opt.)
Format is ASCII Serial; 1 Start, 8 Data, 2 Stops

The Baud rate may be changed to 1200 Baud by removing jumper W50 and installing a jumper from the left pad to the center pad as viewed from the front of the radio. This will become obvious once you have the radio opened up. Many other Baud rates are possible, just look at the schematic.

As long as you are in the radio, lift D-60 to enable the 10 Hz. display. The main tuning knob is varying this digit, so you might as well see it. It also helps when using RIT/XIT as the RIT/XIT display does not resolve the 0.01 KHz. digit. This Modification is in the Radio's Book.

Not in the book is the fact that if you lift D-80 and do an MPU reset, you will be able to transmit on any frequency between 1.5 and 30.0 MHz. This means you will be able to work the Mars nets, Etc. Do not transmit out of band. It is illegal even if it is accidental.

Some computers use TTL levels on their serial ports. If so, here is a time when you will not have to convert it to RS-232. The IF-232 Interface from Kenwood is a 1488 and a 1489 chip in a box. These are an RS-232 Quad Line Driver and Receiver and are available at Radio Shack for \$1.29 Each. Here is an easy project that will save you a lot over the \$69+ Kenwood price of the IF-232 Interface. The 1488 needs a + and - supply.

Unregulated + and - 12vdc is just fine. Get the +5 vdc for the 1489 by putting a 7805 regulator on the +12 vdc supply. 100 mA. is about the max you'll draw, so the smallest transformer you can find will still be plenty large. Don't forget to series up two of each gate to cancel the inversion that the 1480's produce.

ACC-1 Connector Use a 6 Pin DIN Connector.
(Radio Shack \$1.29)

Pin	Signal	Comments
1	Gnd	Signal Ground
2	TXD	Serial Data from Radio to Computer
3	RXD	Serial Data from Computer to Radio
4	CTS	Computer Ready; (Radio Input)
5	RTS	Radio Ready; (Radio Output)
6		No Connection

Pins 4 and 5 may be left Unconnected.

***** Command Description for Kenwood Computer Interface *****

Auto Information

AIn;
The Radio Will Send the Status Info Automatically
Whenever the Operator Manually Varies any Function
on the Radio which is Covered in the IF; Command
Where n = 0 for Auto Info OFF
1 for Auto Info On

The Status Information Will be Sent in the Form :
As defined in the IF; Command

Display Memory

DMnnnn;
This is a Factory Diagnostic Function
and is of no practical use to the operator
The Contents of the MPU Memory will be Read
Where nnnn = MPU Address (0000 Thru FFFF (HEX))
The Contents of the MPU Memory Will be Sent in the Form :
DMnnnn-aabbccddeeffgghhijjkk;
Where nnnn = MPU Address (0000 Thru FFFF (HEX))
aa~kk = Hex Number Pairs Of Next 16 Locations

Down

DN;
The Frequency or Memory Channel
Will Decrement One Step

Frequency VFO A / VFO B Request

FA;
FB;

The Frequency in the Selected VFO Will be Read

The Frequency Will be Sent in the Form:
FAggmmmmkkkhhh; or
FBggmmmmkkkhhh;

Where gg = GHz. Value
mmm = MHz. Value
kkk = kHz. Value
hhh = Hz. Value

Frequency VFO A / VFO B Select

FAggmmmmkkkhhh;
FBggmmmmkkkhhh;

The VFO Selected Will be Set to the Frequency Defined

Where gg = GHz. Value (May be sent As 00 or Spaces)
mmm = MHz. Value
kkk = kHz. Value
hhh = Hz. Value

Function Select

FNn;

The Function Defined Will be Selected

Where n = 0 for VFO A
1 for VFO B
2 for MEMORY

Identify Model Request

ID;

The Model of the Radio Will be sent in the Form :
ID00n;

Where : n = 1 for a TS-940 (*)
n = 2 for a TS-811 (*)
n = 3 for a TS-711 (*)
n = 4 for a TS-440

Read Information Request

IF;

The Status Information Will be Sent in the Form :
IFggmmmmkkkhhh snnnrx yytdfcp

Where gg~hhh = Value as defined in FA Command
s = "+" or "-" Value of RIT/XIT
nnn = Value of RIT/XIT (n.nn kHz.)
z = "0" (Not Used in TS-440)
r = Value as defined in RT Command
x = Value as defined in XT Command
yy = Memory Channel No.
t = 0 for Receive
1 for Transmit
d = Value as defined in MD Command
f = Value as defined in FN Command
c = Value as defined in SC Command
p = Value as defined in SP Command

Lock Knob

LKn;

The Manual Frequency Control Functions Will be Disabled

Where n = 0 for Lock OFF
1 for Lock ON

Memory Channel Select

MCxmm;

The Memory Channel Defined Will be Selected

Where: x = Don't Care (Use "0" or Space)
mm = Memory Channel No. (00 thru 99)

Mode Select

MDn;

The Mode Defined Will Be Selected

Where: n = 1 for LSB
2 for USB
3 for CW
4 for FM
5 for AM
6 for FSK

Memory Read

MRnxrr;

The Memory Channel Defined Will be Read

Where: n = 0 for RX VFO
1 FOR TX VFO (Split Channels Only)
x = Don't Care (Use "0" or Space)
rr = Memory Channel No. (00 thru 99)

The Memory Information will be sent in the Form :

MRn rrggmmmkkkhhhdz ;
Where: n = 0 for RX VFO
1 FOR TX VFO (Split Channels Only)
rr = Memory Channel No. (00 thru 99)
gg~~hhh = Value as defined in FA Command
d = Value as defined in MD Command
z = "0" (Not Used in TS-440)
(Note: Four trailing Spaces)

Memory Write

MWnxrrrggmmmkkkhhhdzxxxx;

The Memory Selected Will be Set to the Frequency Defined

Where: n = 0 for RX VFO
1 for TX VFO (Split Channels Only)
x = Don't Care (Use "0" or Space)
rr = Memory Channel No. (00 thru 99)
gg~~hhh = Value as defined in FA Command
d = Value as defined in MD Command
z = "0" (Not Used in TS-440)

RIT/XIT Clear

RC;

The RIT/XIT will be set to 0.00 kHz.

RIT/XIT Down

RD;

The RIT/XIT will Decrement by 0.01 KHz. (10 Hz.)

RIT/XIT UP

RU;

The RIT/XIT will Increment by 0.01 KHz. (10 Hz.)

19-07-1998

(TS-440) TS-440S increase the power by ALC control

This article also tells how to increase the power of the TS-440 by adjusting the internal ALC control. The procedure is applicable to other rigs.

Illustration captions:

1. Remove 17 screws holding on the bottom and top covers. The bottom cover comes off, and the top cover is carefully removed and put next to the radio. It is still connected via the speaker wire.
2. Gain access to the front of the unit by removing two top side screws and loosening two bottom side screws. This allows the front assembly to swing open.
3. Remove the shiny silver control board protection plate. This requires removing two screws on the top and three screws on the bottom. Lift the plate out completely. Locate diode D-80 in the bottom left-hand corner. Snip it for all-band transmit.
4. Now locate D-66 and snip. It adds 10 Hertz readout to your digital frequency display.
5. Carefully reassemble the control plate using a magnetized tiny screwdriver to hold the five tiny screws in place. Don't pinch any wires. Also, close up the front and replace the top and bottom covers with 17 screws.
6. Connect power. Depress A=B switch and turn on the power simultaneously. This resets the microprocessor for all-band transmit and 10 Hz frequency display.

This modification is read 2336 times.

[top of page](#)

19-07-1998

(TS-440) TS-440 with PIN-Diods

Hallo, ts440-owners!

Recently i read about an upgrade for the ts440 concerning the bandswitch-diodes.

Originally, there are simple switching types built in. For better high level performance i decided to replace D2,3,4,5,6,7,...23,68 by the ECG553 PIN Diode.

The result was not so doubtless positive. i could not really confirm an advantage. unfortunately, i have no measuring equipment for determining the intercept point.

But on 40m , where i sometimes have problems using a 160/80/40/30/20m 5-band fullsize dipole, i still suffer intermodulation effects. I can not really say, if it is much better after the replacement, but i'm sure, it isn't worse (hi).

Some remarkable progress was the usage of the built-in tuner in the receiving pass. that really helped especially on the 10mc band to overcome the problems of interference.

But best results and a final solution i found in using an external preselector as described in the cq-dl several times.

That really did it! Of course you need to add on to cinch connectors at the rear panel.

It is no real problem.

so, my advice:

don't modify the diodes or use of the tuner for reception.

The result is too poor compared with that of an external preselector.

Date: 30-01-2002

User comment

From: [rolf heidenborg SM0CLS](#)

Subject: BC-stn(s) heard regardless of VFO qrg .

I mounted a new 1st mixer, a highlevel injection module type and used old tstrs as as aplifiers and got rid of the bc-stn in the background regardless of VFO setting .

I think there is an oscillation, parasitic, somewhere around the first mixer or that diodes therearound for filterswitching goes into mixing

and "resend" their mixing which then is heard. Will more current through these diodes cure the problem ?

73

Rolf SM0CLS

This modification is read 2095 times.

[top of page](#)

19-07-1998

(TS-440) TS-440S Operation with the MC-85

With some TS-440S transceivers, insufficient modulation may occur when the MC-85 compression switch is turned on. This may be caused by too much of a voltage drop across resistor R172 on the IF unit of the transceiver . If this is found to be the case, change the resistor from 1K ohm to 100 ohms.

Required part

100 Ohm, 1/6 Watt resistor (RD14CB2C101J)

PROCEDURE:

1. Disconnect the power supply and antenna from the transceiver.
2. Using a #2 Phillips screw driver, remove the 9 screws from the top cover of the transceiver. Remove the cover and unplug the speaker wire.
3. Locate resistor R172 on the component side of the IF board (Figure 1).
4. Using a #1 Phillips screw driver, remove the 7 screws that secure the IF unit to the chassis of the transceiver.
5. Pull the board up and rotate it towards the front of the transceiver to expose the foil side of the board.
6. Desolder and remove resistor R172 from the board.
7. Install and solder the 100 ohm resistor in place of R172.
8. Assemble the transceiver by reversing steps 1 - 5.

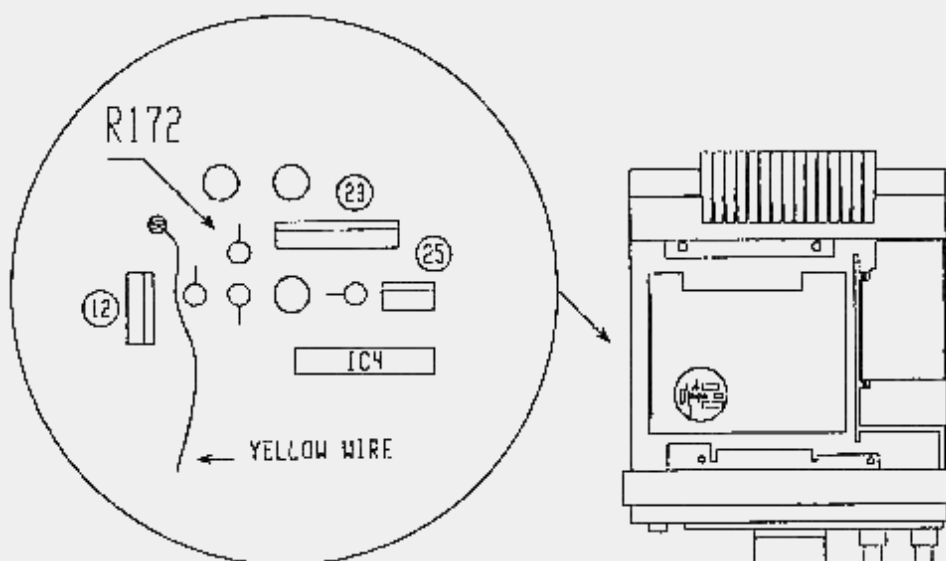

FIGURE 1

This modification may be covered under warranty.
Time required for this modification is 0.5 hrs or less.

This modification is read 1940 times.

[top of page](#)

19-07-1998

(TS-440) TS-440S Notch filter low frequency improvements

Author: Trio-Kenwood Communication, inc.

The low frequency attenuation characteristics of the notch filter can be improved by reducing the input level to the notch filter chip (IC1). To compensate for the loss of input level, the amount of negative feedback to the audio amplifier (IC7) will need to be reduced. This modification is already incorporated in all models beginning with serial number 704XXXX.

Required parts:

120K Ohm, 1/6 Watt resistor RD14CB2C124J

1. Disconnect the power supply and antenna.
2. Using a #2 Phillips screw driver, remove the 9 screws from the top cover. Remove the top cover from the transceiver and unplug the speaker wire.
3. Locate resistors R86 and R229 on the component side of the IF board (Figure 1).
4. Using a #1 Phillips screw driver, remove the 7 screws that secure the IF unit to the chassis of the transceiver.
5. Pull the board up and rotate it towards the front of the transceiver to expose the foil side of the board.
6. Desolder and remove both resistors from the board.
7. Install and solder a 102K ohm resistor in place of R86.
8. Install and solder a 390 ohm resistor in place of R229.
9. Assemble the transceiver by reversing steps 1 - 5.

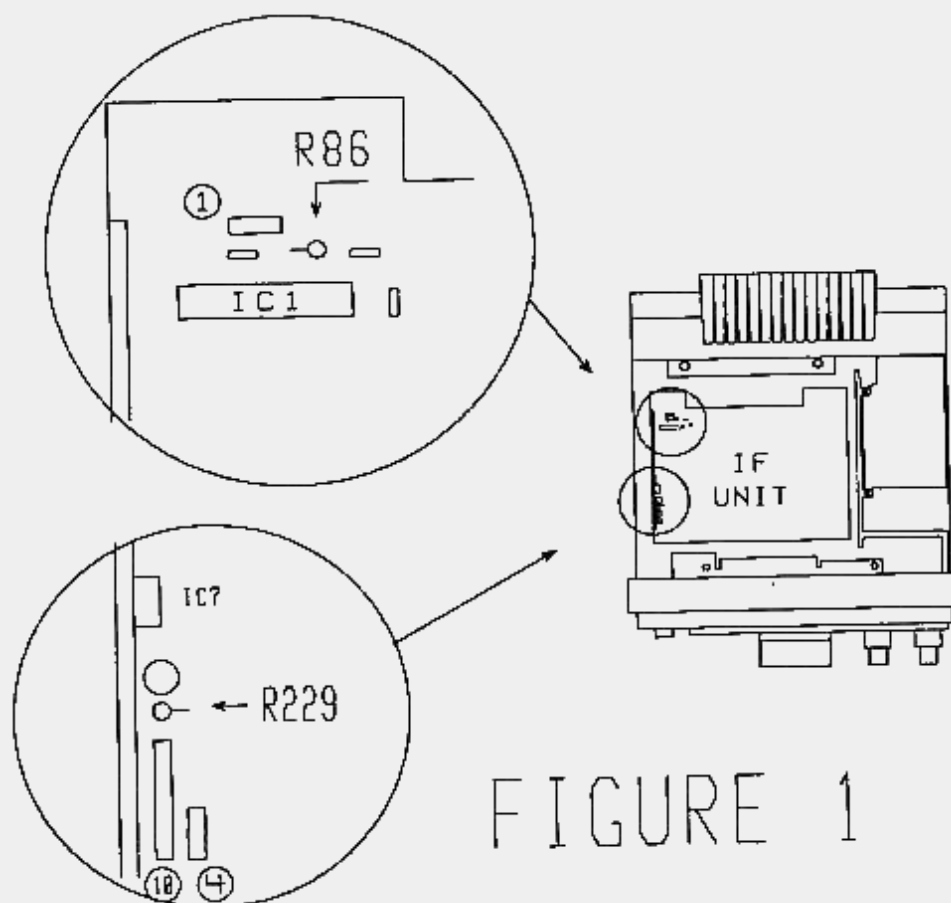

This is an optional change that may not be performed under warranty.
Time required for this modification is 0.5 hrs or less.

This modification is read 1909 times.

[top of page](#)

19-07-1998

(TS-440) TS-440S Protecting Q33

Author: Trio-Kenwood Communication, inc.

Service Bulletin no. 949 (20-1-1989)

If pin 7 (RL) of the remote connector is accidentally connected to ground, current from the 14 volt line (14L) will damage transistor Q33 on the IF unit. This will prevent the radio from transmitting. To protect Q33, a 4.7 ohm resistor should be installed in series with the RL line on the foil side of the IF board. In the event that pin 7 is connected to ground, the resistor will open, but the transceiver will still be capable of transmitting.

Required part:

4.7 Ohm, 1/6 Watt resistor RD14CB2C4R7J

1. Disconnect the power supply and antenna from the transceiver.
2. Using a #2 Phillips screw driver, remove the 9 screws from the top cover of the transceiver. Remove the cover and unplug the speaker wire.

3. Locate connector 19 on the IF unit.
4. Using a #1 Phillips screw driver, remove the 7 screws that secure the IF unit to the chassis of the transceiver.
5. Pull the board up and rotate it towards the front of the transceiver to expose the foil side of the board.
6. On the foil side of the board, locate the trace that is connected to pin 3 (brown wire) of connector 19.
7. Using a craft knife, cut the trace coming from pin three so as to open the foil trace.
8. Solder the 4.7 ohm resistor across the now open trace (i.e. in series with the trace).
9. Assemble the transceiver by reversing steps 1 - 5.

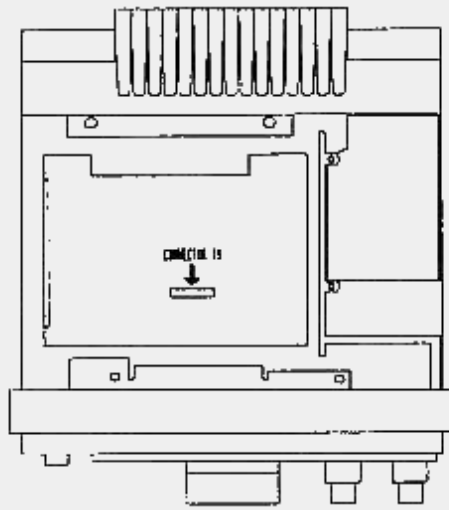

FIGURE 1

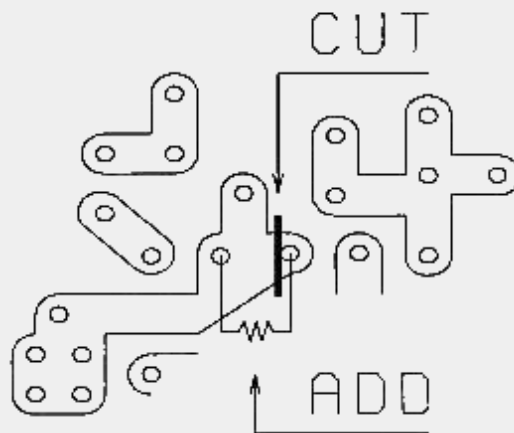

FIGURE 2

This is an optional change that may not be covered under warranty.
Time required for this modification is 0.5 hrs or less.

This modification is read 1934 times.

[top of page](#)

19-07-1998

(TS-440) TS-440S Case Screws binding in the heat sink

Author: Trio-Kenwood Communication, inc.

Service Bulletin no. 950 (20-1-1989)

Occasionally a case screw that fastens to the heat sink of the TS-440S will cross thread or bind when it is being inserted or removed. Binding may be caused by tooling marks on the screw or by burrs on the tapped threads in the heat sink. When a screw starts to bind, DO NOT TRY TO FORCE IT! as this may cause the head to shear off. If the screw is being removed and it starts to bind, return the transceiver to KENWOOD. Do not make attempts to remove the screw. In addition, if a transceiver is being brought to you with a screw sheared off, return the unit to KENWOOD. Do not attempt to drill out the screw.

If a screw starts to bind when it is being installed, carefully back it out. Inspect the screw for marks or burrs and replace it if it is questionable. Since the threads in the heat sink may be causing the screw to bind, they should be cleaned by running a 3 x 0.5 mm tap into each hole.

The tap is inexpensive and can be obtained at many of the larger hardware stores.

To avoid cross threading, make sure the covers are properly aligned when they are being installed. Proper alignment means that there is a clear path for the screw to turn into the heat sink.

This assures that the screw does not rub against the case and result in it turning into the heat sink at an angle.

This modification is read 1820 times.

[top of page](#)

19-07-1998

(TS-440) TS-440 RX Audio Mods

Here's some easy modifications to improve the rx audio fidelity of Kenwood TS-440's. All references below are to the IF board component designations.

- Increase C60 to a .47uf or 1 uf. This will increase low frequency response on all modes.
- Decrease C51 to .01 uf. This will increase high frequency response on SSB/CW.
- Try removing R263 (tacked on the bottom of the board on my early production unit). This will lower in amplitude the audio coming out of the detectors and improved the smoothness (a real technical term) of the audio, especially on AM signals.

And, of course, I take no responsibility for anything you do to your radio. Be careful. The IF board on the 440' is about the easiest one to get at.

73/Dave n2fam@ka3fmo.pa

This modification is read 2128 times.

[top of page](#)

13-05-1999

(TS-440) TS-440S SSB Power-adjustment

From: PA3FKO@PI8ZWL.#OVL.NLD.EU

Hello TS 440 user..

The last few weeks I've seen questions of how to make the power in SSB mode for the TS440S adjustable without changing the Mic-Gain. It's a very easy job to do.

Take off the top cover of the rig.

At that moment you have a sight on the first unit (IF-Unit)

Then you have to look for Diode 49.

You will find Diode 49 at about 5 CM from the backend of the unit and about 6,5 CM from the leftside of the unit.

Just next of C138 and between plug 38? (red/orange wires) and plug 26 (black-cover/blank wires) Just cut that Diode 49, bend one part a little away and leave the part's where they are. It's the best way to do I think.

Replace the topcover.

From now on it is possible to adjust only the power in SSB mode by just turning the CARRIER Control at the front of your rig and leave the Mic-gain for where it is.

Turning counterclock will minimize the power until a 20mW or something like that.

Because most TS440 users have'nt used their carrier control that much I think it's better to pull off the MIC/CAR knobs and spray some contact cleaner in the shafts. (I know, it's not the best way).

When you switch your rig into the CW mode you can adjust the power in what you like, switch the mode in to USB or LSB and if it is correct the power will not come above the level that what you have adjusted in the CW mode.

Just simple, is'nt it?

Of course you will do this all in your own responsibility because I won't take any!!! Agree?

Vy 73 Willem.

This modification is read 2523 times.

[top of page](#)

Author: Trio-Kenwood Communication, inc.

Service Bulletin no. 952 (24-1-1989)

When intermittent problems such as erratic display, loss of front panel control, or frequency lock-up are encountered, the PLL and Control circuits must be checked to determine which circuit is malfunctioning. While any number of components may cause such problems, if the Control circuit is suspect, there is a possibility that the ROM socket is at fault. The socket should be tested to determine if it is making good electrical contact with each pin on the ROM. If it is found to be defective, remove the socket and solder the ROM directly to the board. The ROM is IC52 on Control unit (B/2). It should be noted that units with serial number of 909xxxx and above do not incorporate a socket.

Caution

Removing the socket requires good soldering skills. The ROM is mounted on the Digital A unit and is designated as IC2. The board, being double sided, has solder connections on both component and foil sides. When the socket is removed, it is very important to insure that each pin is completely solder free. Having to pry up on the socket means that it is not completely desoldered and will cause the circuit foils to tear.

When performing any work on the Control boards, CMOS handling techniques must be observed. Such techniques include using a grounded or isolated soldering tip, avoid touching the pins of IC chips with your fingers, and ground yourself with a wrist ground strap.

To remove the socket:

1. Disconnect the power supply and antenna.
2. Remove both the top and bottom covers from the transceiver. Disconnect the speaker cable from the transceiver.
3. Remove 2 countersunk screws from each side of the front panel chassis and gently pull the front panel forward.
4. Loosen the 5 round head screws (2 on top and 3 on the bottom) that secure the shield plate inside the front panel and then remove the plate.
5. Set the transceiver on its left side and fold the front panel back to expose Control board (B/2). Do not stress the cables.
6. While avoiding contact with the pins, remove the ROM (IC52) and set it aside on anti-static foam.
7. Unplug connectors 56 - 58 from Control board (B/2).
8. Remove 3 brass screws from Control board (B/2). Do not remove the fourth screw that connects to the angle bracket. Instead, remove the brass screw from the Control board (A/2) so the angle bracket stays with the top board.
9. Fold the top board towards the body of the transceiver. Be very careful not to stress the flat ribbon cables that are soldered between the two boards.

Note

If the foil side of the board is not sufficiently exposed for desoldering purposes, remove the 3 hex bosses from the bottom Control board. Pull both boards forward and open them like a book to allow the best access to the foil side of Control board (B/2).

10. Carefully desolder the socket and remove it from the board. Do not pry up on the socket. If it does not easily pull off the board, the top foils are still soldered to the socket.
11. Install the ROM in the board and solder it in place.
12. Assemble the transceiver by reversing steps 1 - 9. If the bottom board was removed, do not pinch the wire harness under the board during installation. If the harness produces excessive stress on the board, solder connections may become intermittent.

This modification may be covered under warranty during the warranty period.

Time required for this modification is 1.5 hour or less.

21-04-2000

(TS-440) TS-440S PLL unlock due to VCO #5

Author: Kenwood Communication, inc.

Service Bulletin no. 973 (8-8-1990)

The VCO and active low pass filter are sealed in synthetic rubber to mechanically stabilize them during mobile operation. Over a period of several years, the rubber's insulation properties can break down. This may be caused by repeated temperature variations. This can cause the VCO to vary in frequency which will force the loop to unlock or cause the audio to warble.

This modification will correct or prevent an unlock caused by VCO #5.

Required parts:

2SC2459 (BL)	Transistor	QTY. 2
1SV153	Varactor diode	QTY. 1

1. Disconnect the power supply and antenna.
2. Remove the top and bottom covers. Do not damage the speaker wires when removing the top cover.
3. Remove the two screws from the rear of the IF unit and raise the unit to expose the PLL board.
4. Remove the 8 screws from the PLL board and disconnect all the cables going to the board.
5. Remove the board from the transceiver.
6. Remove the shield cover from VCO #5. Desolder and remove the shield from the PLL board.
7. Carefully remove the synthetic rubber from the area of Q34, Q35, and D14. The rubber must be picked off the board with pointed tweezers or some other tool. It cannot be removed with any type of solvent as this will harm the components in the area.
8. Desolder and remove Q34, Q35, and D14 from the PLL board.
9. Check the component side of the board to make sure all the rubber in the area of Q34, Q35, and D14 is removed.
10. Once the rubber is removed, replace Q34, Q35 and D14 with new components.
11. Inspect and resolder the foil side of the PLL board under VCO #5.
12. Install the VCO shield on the PLL board and solder it in place.
13. Seal the VCO with hot melt glue (glue stick used in a hot melt glue gun). Apply the glue to the circuit from the glue gun. Once the area is covered, use the hot air gun to flow the glue around the components. Do not overheat the components.
14. Install the PLL board in the transceiver.
15. Apply power to the transceiver and allow it to run in receive for about a half hour so the transceiver's temperature stabilizes.
16. Set the operating frequency to 14.200 MHz.
17. Adjust T20 to obtain 5 Vdc at TP11 (the exposed lead of L40) measured with a DVM or VTVM. Do not use a VOM. After adjusting the VCO, bench run the transceiver for an hour or more to make sure the circuit is stable.
18. Assemble the transceiver.

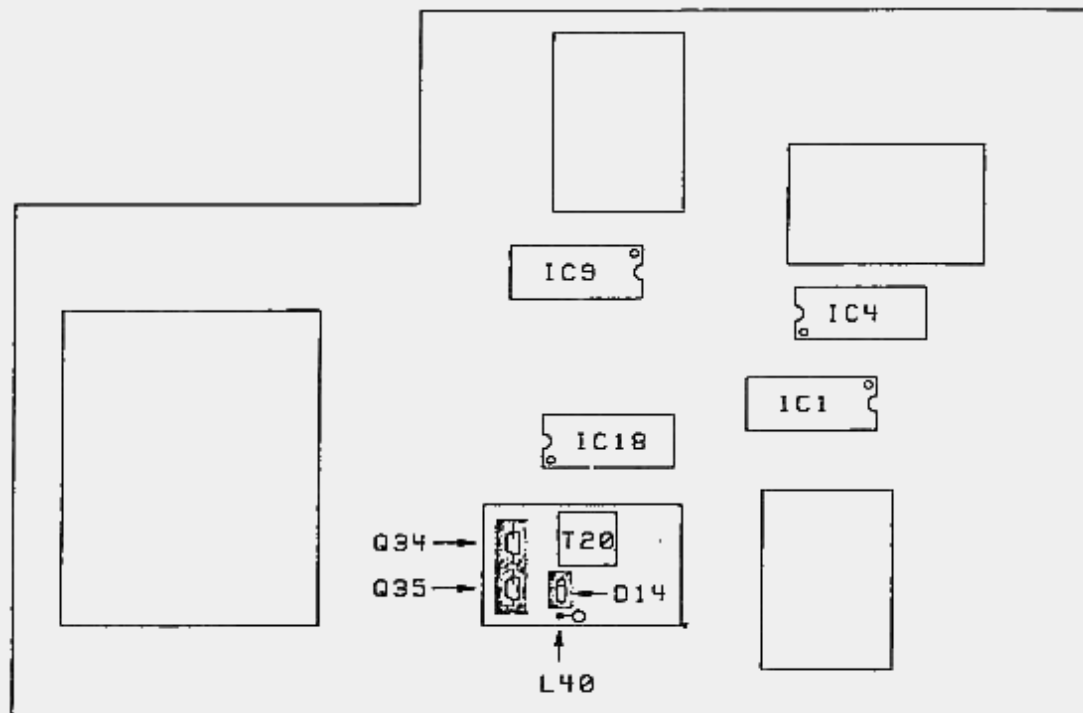

Time required to perform this modification is 1 hour or less.

This modification is read 2171 times.

[top of page](#)

21-04-2000

(TS-440) TS-440S PLL unlock due to VCO #1

Author: Kenwood Communication, inc.

Service Bulletin no. 974 (8-8-1990)

The TS-440S Control unit supplies band information to four circuits in the transceiver. The circuits are the receiver front end Band Pass Filter (BPF), the antenna tuner (AT), the transmitter Low Pass Filter (LPF), and the VCO circuits on the RF board that are part of PLL #1.

There are ten receiver front end BPFs that are diode switched into operation. If one of the diodes (D4-D23) becomes shorted or leaky, the band information is felt at two BPFs at one time. The voltage going through the bad diode will loop back to the VCO circuit, antenna tuner circuit, and LPF circuit.

The unwanted voltage will then create one or more of the following symptoms:

- A. PLL unlock (the transceiver only displays decimals).
- B. No antenna tuner operation.
- C. Low receiver sensitivity.
- D. Low or no transmit power output.
- E. Distorted transmit audio.
- F. RF feedback.

The most common symptom is the PLL unlock. To test the diodes, remove the large shield on the RF board to expose the BPF circuits. Reset the transceiver by holding in the A=B button as power is turned on. Even if the display only shows decimals, only the BPF for 14 MHz should be turned on. Using a DC voltmeter, measure the voltage at coils L11, L15, L21, L28, L34, L40, L46, L52, L58, and L62. Only coil L52 should measure 8 Vdc. The other coils should read 0 Vdc. If one reads 0.5 - 8 Vdc, replace the two diodes in that BPF circuit.

Coil/Diode/frequency range relationship:

L11	D4	D5	0 - 0.5 MHz	L15	D6	D7	0.5 - 1.6 MHz
L21	D8	D9	1.6 - 2.5 MHz	L28	D10	D11	2.5 - 4 MHz
L34	D12	D13	4 - 6 MHz	L40	D14	D15	6 - 7.5 MHz
L46	D16	D17	7.5 - 10.5 MHz	L52	D18	D19	10.5 - 14.5 MHz
L58	D20	D21	14.5 - 22 MHz	L62	D22	D23	22 - 30 MHz

Replacement diode part number

1S2588 or 1SS91S: D4, 6, 8, 10, 12, 14, 16, 18, 20, 22
 BA282 D5, 7, 9, 11, 13, 15, 17, 19, 21, 23

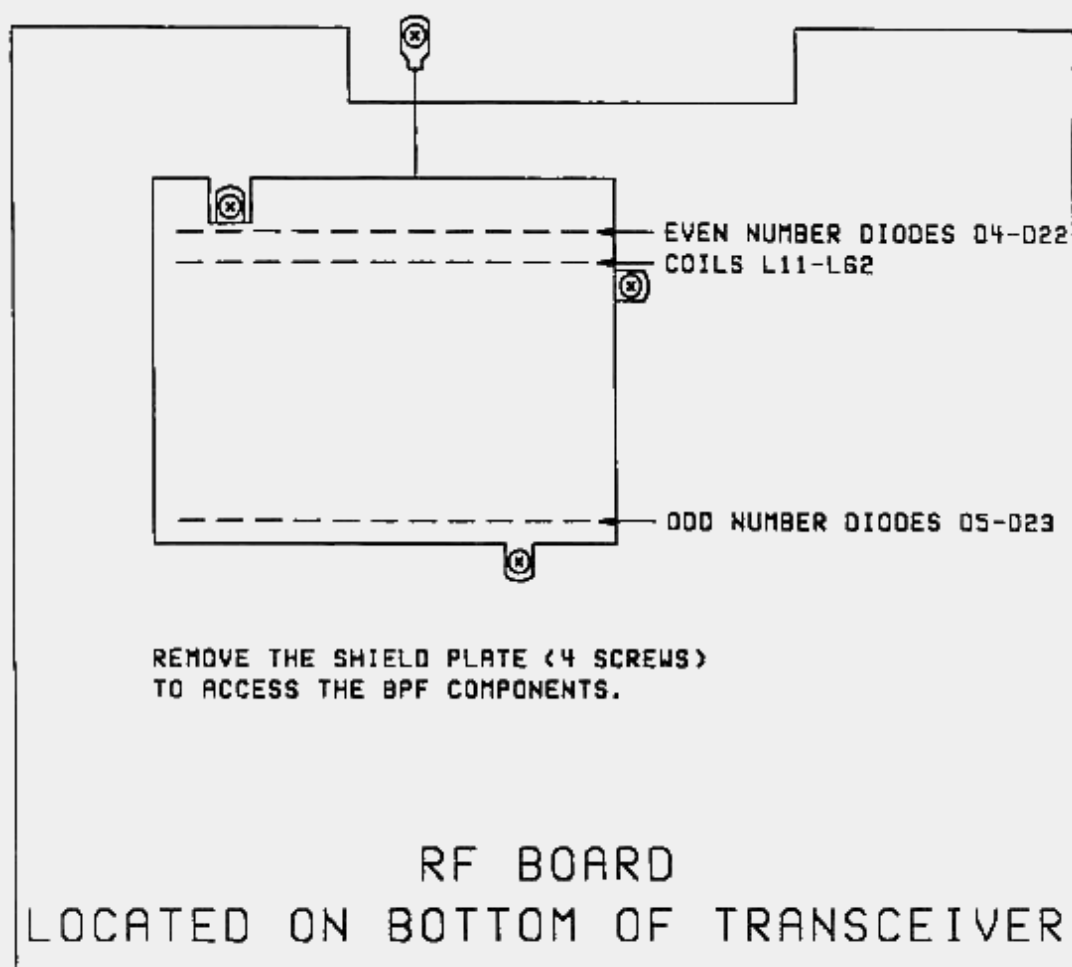

Time required to perform this modification is 1 hour or less.

This modification is read 2075 times.

[top of page](#)

15-10-2000

(TS-440) TS440S mod for improved receive sensitivity of 0.5 to 1.6MHz

Author: Robert Casey - wa2ise@ix.netcom.com. MODIFICATION.NET

TS440S mod for increasing sensitivity on the MW AM broadcast band:

(Removes MW attenuator pad). The TS440S has an attenuation pad hard wired on the spectrum between 500KHz and 1600KHz. You can open up sensitivity by removing it. On the RF unit board, clip a lead on R13 (68 ohms), clip a lead on R14 (68 ohms), and solder a jumper across R12 (220 ohms). These are under a shield held down by screws on the RF board.

I've noticed no intermod problems and only the strongest stations (above S + 40) overload (which can be solved by using the front panel attenuator button).

Proceed at your own risk.

This modification is read 2111 times.

[top of page](#)

24-07-2001

(TS-440) Circuit Improvements for the TS-440S

Author: Richard L. Measures, AG6K

Problem: Limited transmit frequency coverage.

Fix: Cut D80 on the Control Unit for 1.6MHz to 30MHz transmit capability. D80 is about 2" from D66, which is cut for 10Hz frequency readout.

Problem: Lack of crispness in the RX audio, which makes the sibilant parts of human speech hard to distinguish from each other. This is caused by a -p;5db roll-off at 3000Hz in the RX audio.

Fix: Change C51 [0.033µF] on the IF Unit, near L5, to .005µF [5000pF/5nF]. This will reduce the roll-off to a more acceptable -p;1.4db at 3000Hz. "After modification, the RF Gain control should be backed off [CCW] until the band/sky-noise decreases to a comfortable listening level. This will not interfere with the reception of moderately weak signals.

Problem: Even while listening on a large, external speaker, music sounds flat and tinny because the audio frequency response rolls

off below 200Hz.

Fix: There are a number of capacitors in the RX audio amplifier circuits that can be increased in capacitance to restore the low-end audio. These capacitors are in the IF Unit. They are: C60, C66, C67, C69, C170 and C175. The increase in capacitance should be 4 times. {Note: Some capacitors in the audio circuitry can not be arbitrarily increased in value without causing unacceptable tradeoffs.} C175 can be replaced with a 1000 μ F, 10V unit, whose full-length leads are sheathed in Teflon sleeving, except for the last 8mm, to allow soldering to the PC board. This is done because the board-space allotment for the stock C175 is too small for the larger, replacement unit. The new capacitor is folded over and tucked in appropriately.

Problem: Tinny/thin-sounding transmit audio.

Fix On the IF Unit, change C135 {0.1 μ F}, near the center-board fastening screw, to 0.47 μ F.

Problem: The stock, muRata CFJ455K14 SSB filter in the 455KHz IF has a selectivity shape-factor of 2 to 1. This is definitely less than wonderful. The stock SSB filter in the TS-830S and TS-940S has about the same bandwidth at minus 50db, but it has a much better shape factor and it is mechanically and electrically interchangeable with the stock filter in the TS-440S. The better filter is a muRata CFJ455K12 or CFJ455V12, which will noticeably improve the transmit and receive, SSB audio quality of the TS-440S. This filter is available from Trio-Kenwood as p/n: L72-0333-05 for \$42.89 {Dec 1989}. If you want SSB double-filtering in the 440's RX, the TS-940S' matching, 8.83MHz, YK-88-S1, 2.7kHz SSB filter is available from Trio-Kenwood as p/n L71-0222-05]. for \$66.62 {Dec 1989}. This filter goes in the optional SSB filter space on the IF Unit. For listening to an uncastrated-male voice, the YK-88-S1 will produce better-sounding, and more understandable, audio than the Kenwood-recommended optional YK-88-S, 2.4kHz filter. A pair of TS-940 SSB filters will give the 440 the same superb selectivity that comes with the 940.

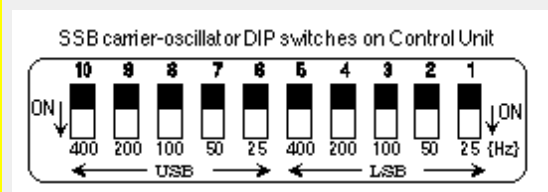

Alignment: Supply a signal to the receiver. Set the TS-440S' selectivity switch to M2, the single filter position. The USB and LSB carrier oscillators [DIP switches on Control Unit] should be reset so that there is roughly 20db of RX, SSB carrier-suppression for each sideband at zero-beat. [use the 440's 20db ATTN as a standard] {Use 15db rolloff at zero-beat for more low-end audio, or 25db roll-off for more high-end audio and/or better unwanted sideband suppression} This completes the alignment of the carrier oscillators. >>> If you installed BOTH filters: on LSB tune the 440 above the calibrator's zero-beat frequency and note the 20db (or the roll-off db you used above) roll-off point. This should be around 3.1KHz, \pm 200Hz higher than zero-beat. Put this frequency & LSB into VFO B. Put the zero-beat frequency & LSB into VFO A. With the Selectivity switch set to M1 [double SSB filter], the 8.375MHz oscillator on the IF Unit is adjusted [TC2, in the lower left corner of the PC board] so that the improved skirt selectivity on the double filter position is equally distributed between the zero-beat 20db rolloff point [VFO A] and the high-frequency 20db rolloff point [VFO B]. The comparison can be done by watching the S meter and repeatedly pushing the A/B button on the 440. [use fast AGC to reduce settling time] Note 1: TC2 is installed backwards on the PC board so that the rotor adjustment slot on TC2 is hot instead of grounded. This causes the capacitance of TC2 to change when a metal screwdriver is used to make the adjustment.

To fix this problem, TC2 is removed, reversed 180 degrees and re-soldered on the PC board. Note 2: see IF Unit schematic, CF2, the AM filter. There is a 1K Ohm resistor [R49] in series with the input [D13] to the filter. This resistor provides a closer impedance match between the 2000 Ohm filter and the source [L4]. A similar resistor can be installed in series with D12 at the input to CF1.

Problem: RX audio distortion. {This problem seems to be more prevalent in early production radios. There may have been a recent factory component change to reduce receive distortion.} There is one designed-in source of distortion and several other possible sources of distortion. The designed-in source of distortion exists because not enough forward bias current is applied to the switch diodes that select the SSB [D23], AM [D24], and FM [D25] audio detectors. Here's why: A mixer is a nonlinear device. Nonlinearity and distortion go hand in hand. Diodes make good mixers when their forward current is in the range of 0.05mA to about 0.6mA. At currents above 1.5mA, diodes are reasonably linear and they make good switches. The switch diodes in the TS-440S have enabling currents of from 0.2mA for FM to 0.28mA for SSB, so the switch diodes are operating in the region of maximum nonlinearity, which results in distortion. The fix is simple: Increase the forward bias DC-current through the diodes to roughly 2mA. This is accomplished by decreasing the resistance of each DC-bias resistor to about 1k Ohm. When these resistors are decreased in value, the 5000 Ohm impedance of the low-level audio circuits decreases to about 500 Ohms and the values of the coupling capacitors must be increased accordingly to prevent a rolloff of the low frequencies. Similarly, the resistors that are in series with the audio signals in these circuits must be decreased in value to offset signal attenuation. The capacitance of the filter capacitors between switch diode bias resistors (for SSB: C52, 4.7 μ F) must be increased to compensate for the decreased value of the bias resistors.

Fix for SSB audio detector and D23 switch: In the left, rear corner of the IF Unit, change: R71, R73, R74, and R85 to 1k Ohm; C53 to 47 μ F, 10V [XL=68 Ohms at 50Hz]; C52 to 22 μ F, 16V.

I'm guessing that similar changes can be made in the AM and FM detectors. This project can become tricky since some of the needed changes can also affect the transmit+receive transition performance of the radio. Thus, it may be necessary to compromise by lowering the switch diode bias current to about 1mA. In general, this can be done by using 2k Ohm, instead of 1k Ohm, bias resistors. If, after the changes are incorporated, you can still hear RX distortion on SSB, the problem may lie at the

[right-adjacent] product detector. Possible FIX: Install the missing injection-oscillator terminating-resistor at the product detector. This resistor is 62 Ohm, 1/8W or 1/4W. It is soldered under the IF Unit PC board, near L5. The terminating-resistor is soldered to the junction of R69 and R70 and the ground foil at the edge of the PC board. If the distortion persists, you may have an unmatched set of Germanium product-detector diodes: D19, D20, D21, and D22. These diodes can be replaced with Schottky diodes. The product detector balance should then be checked and adjusted as follows: Connect an RF detector to the emitter of Q9/R77. R77 sticks up from the board at one end so that the test connection can be easily made. The RF detector can be an oscilloscope, detector/probe for a DMM, or a 455KHz receiver coupled through a 10pF capacitor. With no signal input to the ANT jack, turn the RF Gain on the 440 to zero. Set mode to USB, IF Shift to detent. Adjust TC1 [also installed backwards, like TC2] for minimum RF. End of test. Reset the RF Gain control to normal.

Problem: AGC overshoot while receiving strong SSB signals. The symptom is audio distortion on peaks only. The distortion is reduced when the RF-gain control is backed off.

Fix: On the RF Unit, near J13, near Q5, change R42 from 470k Ohm to 10k Ohm. This speeds up the attack response of the AGC.

Problem: TX frequency response is not the same as RX frequency response with the IF Shift control set on detent.

Fix: Connect a frequency counter to IF Unit, J26, pin 2 and ground. With the IF Shift on detent, the frequency [roughly 455kHz] of the carrier oscillator should not change between TX and RX. If the frequency changes, adjust VR7 until the frequencies are equal. VR7 is just behind the MIC pot and the top of the front panel; it is mounted on a small, PC board.

Intermittents. The interconnecting wires in the TS-440S are copper. The tin-plated single-row connector pins that are crimped to these copper wires form a dissimilar metal junction that is subject to electrolytic action due to moisture in the air. Some of these crimp connections may eventually fail to provide electrical contact due to electrolysis.

Fix: Remove the defective connector pin by depressing the ratchet-tab in the slot on the side of the connector pin and pulling the freed pin from the connector body. [The ratchet-tab can be depressed with a small screwdriver.] The copper wire that protrudes past the crimp is then electrically bonded to the pin with solder or Silver Print [GC Electronics] conductive paint. The wire/crimp junction should be inspected with a magnifier before the pin is re-inserted into the connector. If a wire/crimp junction is soldered instead of being dabbed with conductive paint, it is difficult to prevent the heat from melting the plastic insulation on the wire. If soldering is the choice, the rosin flux residue should be removed from the pin with alcohol, or acetone.

The same type of intermittent problem may also occur in the coaxial connectors. The fix is to apply conductive paint between the crimp on the center conductor pin and the copper wire.

An intermittent frequency display or wandering SSB receive frequency can be caused by a dirty socket-to-chip contact on IC52 in the Control Unit.

On later production radios, IC52 may be soldered in. The same symptoms can also be caused by a bad solder connection on R152 in the 36MHz VCO [VCO #5] at the front-center of the PLL Unit, near T20. Another common problem with VCO5 is L41 [10 μ H] which apparently suffers from an intermittent internal connection. L41 is potted, so the best fix may be to replace it.

A **very** common problem with VCO5 is that the type of glue that is used to mechanically bond the components together appears to absorb moisture from the air (it is hygroscopic). Since water has a dielectric constant of 79, its presence can cause much grief in an RF circuit. Thus, the moisture that is absorbed into the glue can cause the oscillator to unlock.

Fix: Remove the original glue with solvent and a knife. If the glue is not replaced, VCO5 will exhibit microphonic problems. Some types of clear hot-glue seem to work well for replacing the original glue. Re-adjust VCO5 after the glue has set up.

Problem: No direct access to RX input or RX mute. These capabilities are necessary if the 440 is to be used as a slave-receiver in conjunction with another transceiver.

Fix: On the IF Unit, connect a wire from the base of Q39 to J22, pin 2. Remove R176, near J22. On the X41-1610-00, (M/14) Switch Unit at the rear of the 440, jumper across R46 [10K Ohm]. The RX will now mute when the FSK IN jack is grounded. {FSK TX is still possible if the AFSK is fed into the MIC jack through a 10 to 1 voltage divider.} The receiver input access can be brought out to the ACC 3 connector by connecting a 27 Ohm to 51 Ohm 1/4W resistor to J29, pin 2 on the X41-1610-00, (N/14) Switch Unit. A short length of wire connects the other end of the 1/4W resistor to the center of the ACC 3 jack which is now the RX input. When slaved to another transceiver through the transverter port, this arrangement allows the operator to simultaneously listen on 2 frequencies with stereo earphones. This provides an advantage to the user when working DX on split frequencies.

Problem: There is no way to adjust the reference frequency oscillator with the case on. If the frequency is adjusted with the case off, the frequency will be different with the case on.

Fix: drill a 7mm to 8mm hole in the left side of the bottom half of the case. The hole should line up with TC1 on the PLL Unit. The position of the hole can be located with the case in place. The horizontal measurement is 122mm back from the edge of the front panel that wraps around the left side of the radio. The vertical measurement is 6mm below the edge of the top half of the case that overlaps the bottom half of the case.

To adjust TC1: [You must have 10Hz readout enabled] Tune to 10.00000 MHz WWV, USB or LSB. Select W [wide] on the selectivity switch. Wait until the tone modulation is present. You will hear both sidebands. If the 2 tones are not the same, adjust TC1 until the tones zero beat.

Problem: On QSK and on SSB VOX, it does no good to back off the RF Gain control to reduce the nuisance of static crashes or band noise. This is because the factory stock receiver comes on full-bore whenever the TS-440S transitions from TX to RX - even if the RF Gain is backed off!

Fix: On the IF Unit, change R36, near Q5, to 2M Ohm; change R60, near Q7, to 510K Ohm. \pm a few standard values will make little difference.

Problem: Your own transmit RF gets into the TS-440S through the EXT SP jack and causes audio rectification that is heard in the external speaker.

Fix: The sleeve/shield terminal on the EXT SP jack should be bypassed to ground on the (G/14) Switch Unit with a 2nF to 20nF, 500V, disc ceramic capacitor.

If the problem is most severe on 10 meters, try 2nF [.002 μ F]. If the trouble is most severe on 80m or 40m, try 20nF [.02 μ F].

Problem: You can hear distorted audio coming out of the internal speaker while you are transmitting on SSB.

Fix: Remove the top cover on the radio and re-position the internal speaker wires away from the area around the SSB filters. The speaker wires should be confined to the area around the speaker plug on the IF Unit. Also, keep the speaker wires away from the Control Unit behind the digital display.

Problem: Key-clicks on CW. This is caused by too fast (500 μ S) RF output rise [make] and fall [break] times.

Fix: On the IF Unit, change C168, near Q49, to .22 μ F; change R225 to 33K Ohm-43K Ohm. {the factory's "fix" for this problem is OK on make but it still clicks on break}. Unfortunately, fixing the key-click problem also seems to affect the full breakin make timing in the 440 which clips the first dit. Thus, if you want to use the 440 on full, instead of semi, breakin, you must put up with the key-clicks.

Problem: The amplifier-keying-relay, RY2 on the (N/14) Switch Unit, makes too much noise, or the contacts on RY2 have burned and pitted, or all of the above. Another problem with RY2 is that it is too slow to use with a full-QSK amplifier. This needless make-delay can cause the amplifier to hot-switch, burning the contacts in its QSK-relays.

Fix: replace RY2 with an NPN switching transistor and fix the current pulse problem that pitted the relay contacts, which may also damage the transistor. [only works for amplifiers with positive voltage relay control]. If your amplifier uses positive 110V for the relay control, like the SB-220 and the TL-922, the relay pitting is caused by the current pulse from the repeated shorting out of the charged .02 μ F bypass capacitor across the amplifier's relay control jack. The bypass-capacitor can be removed if shielded wire is used for the interconnection cable to the transceiver. Another fix is to install a 150 Ohm to 200 Ohm, 1/4W series resistor at the relay control jack to limit the discharge current to a value that the relay or switching transistor can handle. The bypass capacitor is connected to the relay-side of the resistor.

Transistor Installation Notes: The N/14 Switch Unit is located just behind the ANT RF connector on the rear panel. The small access panel on the bottom, rear of the radio is removed to gain access to the N/14 Switch Unit. Two chassis-ground connections and one center pin connection must be unsoldered from the RF connector before the Switch Unit can be removed. Unplug the three connectors, remove the two sheet metal screws, and lift out the Switch Unit. Unsolder and remove RY2, D16, and the white jumper-wire and the pin that it plugs into. Install one 1k Ohm resistor each in place of D16 and in place of the jumper-wire and its pin. The transistor will solder in place of the relay if its full length leads are bent to fit the available holes. The emitter goes to common-ground, as does the trace to J30, pin4 [CMC], the ground return for the relay control circuit. The base lead connects to the trace that goes to R2 {D16} and C37. The collector solders to the trace that connects to J30, pin 2 [TXC].

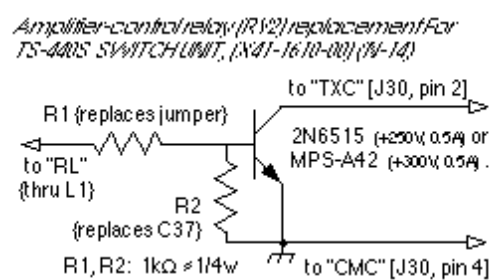

Problem: Poor skirt selectivity on AM.

Fix: The unsatisfactory, stock, TS-440S AM filter, CF2, can be directly replaced with the better performing, AM-narrow, 6KHz filter from the Trio-Kenwood R-1000 receiver. The part number of this filter is L72-0319-05 and the price is \$9.10 {Dec 1989}. It is available as a replacement part. Even though the better filter has more pin connections and is physically larger than the original filter, the IF Unit printed circuit board was designed to accept either AM filter. The design engineers must have realized that some people would want to install a good AM filter.

CF2 is a small, black, cube-shaped plastic component at the rear of the IF Unit just slightly to the right of left-to-right circuit board center. No realignment is necessary after the AM filter is replaced.

Maintenance: The VFO tuning knob should be removed, after loosening the 1.5mm hex-socket set-screw, and the tuning shaft's bushing-bearing should be lubricated with a modern semi-synthetic lubricant like Break Free or Tri Flow. The quantity of lubricant used should be small and the radio should be tipped back to help the lubricant run down into the bushing-bearing. This should be done once when the radio is new and roughly every 4-years thereafter.

Double-sideband modification for the TS-440S

Occasionally, it may become advantageous to use double-sideband-transmit and single-sideband receive mode in order to thwart the efforts of radio sociopaths who are gratified by interfering with others. DSB-xmit/SSB-RX mode gives the non-interfering stations the option of listening to the sideband that has the least amount of interference.

To install DSB capability in the TS-440S, the audio processor switch is rewired so that when the switch is depressed, the carrier is removed from the AM transmit signal. Without a carrier, AM becomes DSB. {The DSB modification will disable the less-than-worthless audio-PROCESSOR in the TS-440S.}

The modification: On the IF Unit [the top board] locate R179, which is between IC4 and Connector 21 at the front, left of the circuit board. Remove R179 and connect a jumper wire from the right hand, empty solder-pad hole on the circuit board [collector of Q41] to the junction of D45 and R196, which is straight back on the circuit board, just to the left of IC5; about 4cm from the rear of the circuit board.

To enable DSB transmit/SSB receive, "SPLIT" operation is utilized:

1. Program VFO A=B.
2. Program VFO A for either USB or LSB, depending on which one has the least interference.
3. Program VFO B for AM and push the PROC [DSB] switch in to remove the AM carrier.

4. Select VFO A.
5. Program SPLIT operation. The 440 will now listen on VFO A and transmit on VFO B.
6. Set the carrier control straight up to position #5 [12 o'clock].
7. While transmitting, adjust the MIC gain control for a small amount of ALC. This keeps the DSB bandwidth to a minimum.

While listening [VFO A], it may be necessary to select the sideband that has the least amount of interference. If your friends are also transmitting on DSB, you may be able to continue communicating, despite the efforts of those who would like to spoil the enjoyment of others.

>>> *DSB should not be used unless the other sideband is vacant.* If the interfering station or stations can cause the group that they are interfering with to interfere with a third group, it will definitely make their day.

Most jammers enjoy being talked about, either positively or negatively. This is why they usually switch back and forth between receive and transmit. If you want a jammer to stick around, talk about him. Stupid insults usually work best.

This modification is read 2581 times.

[top of page](#)

19-07-1998 (TS-450) KAM-PLUS Problems!! with TS-450 & 850

Hello All,,

A common problem when using a KAM-Plus multimode with the Kenwood TS-850 or TS-450 occurs when the KAM-Plus is coupled to the Accessory-2 socket on the back of the transceiver, producing noticeable distortion of the transmitted audio when using the microphone in SSB mode..

The problem is easy to cure by disconnecting the Accessory-2 plug from the back of the transceiver, but this meant moving the transceiver around every time one wished to operate on SSB..

The problem is caused by the input sensitivity of the rear Accessory-2 socket being set to high, so that it picks up very low level noise from the KAM-Plus and associated computer wiring, this mixes with the microphone signal, to produce the distortion.

The cure is to reduce the input sensitivity of the radio, thus reducing the chance of distortion, also it goes without saying that the output from the KAM-Plus must be increased to compensate for this.

With both the TS-450 and TS-850, adjusting the input sensitivity is straight forward and the transceiver manuals show you the appropriate control and its location.. This is in both cases VR18 to be found on the main board of the radio, (refer to manual) in practice I found that it was best to adjust this control fully counterclockwise..

Then we need to adjust the output from the KAM-Plus by varying potentiometer R28 and setting removable link (K9), this link is factory set on one post only, (in the open position)!! this should be connected shorting the two posts, thus putting the KAM-Plus into the high output position, and then potentiometer R-28 is adjusted to give full power out from your HF radio with very little ALC deflection, when the MIC gain is in the normal operating position..

Then I am sure you will find that your problem is over, you can now simply change from digital modes to SSB.. Remember if you have your Beacon activated to turn it OFF or it could cause a few comments when operating SSB..

This modification is read 1384 times.

[top of page](#)

19-07-1998 (TS-450) General coverage transmisson modification for the TS-450 and TS-690

1. Remove all screws of top and bottom case.
2. Remove two screws of front panel (left and right top side), and loosen two screws of front panel (left and right bottom side).
3. Remove all screws of digital unit (X46-312X-XX).
4. Cut the chip diode D27 (RL73) on digital unit rear side.

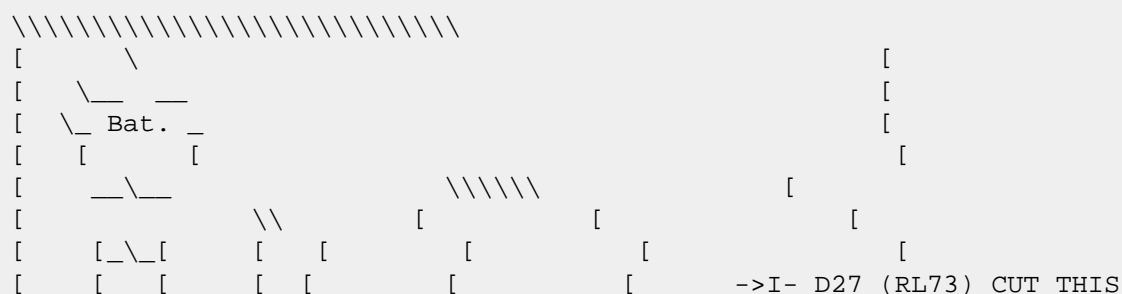

```
[ [ [ _ _ [\\_\\_ ->I- D26
[ [ \ [ \ ->I- D25 [
[ ->I- D24 [
[ ->I- D23 [
[ ->I- D22 [
[ ->I- D21 [
[ ->I- D20 [
```

DIGITAL JNIT (X46-312X-XX) Component side view

Best 73 Eric St-Pascal Kam. Qc. VE2MEL

This modification is read 1987 times.

[top of page](#)

19-07-1998

(TS-450) TS-450S Intermittent receive fixed

After making a careful mobile installation, WBOBQV found his TS450S to have intermittent receive. He removed the screw that was going through the coax in his car and made a second installation in his truck. More intermittent. With some careful diagnosis he found that moving the coax connector up and down caused the change in signal. With the radio opened up, I found that moving the coax connector was breaking the contact between the wire from the center conductor and the board (W1 in the schematic). To save on pulling the filter board, I used a short piece of very flexible test prod wire to connect from the center of the UHF connector to W6 on the top of the PC board. W6 jumps over the contacts of a relay used only in the TS-690S. For added security, I also added another wire of the same material from the ground lug on the UHF connector to the end of D11 away from the coax connector. So now if the flexible back panel breaks the other wire too, it won't have so much effect. The coax connector is mounted on a 1/32" plated steel panel so is excessively flexible in mounting. Ideally that connector should be mounted far more stiffly for those that use real RG-8 coax.

This modification is read 1418 times.

[top of page](#)

19-07-1998

(TS-450) TS-450,TS-850 feedback,ACC-2 Conn

Hi if you are using the ACC-2 connector to interface with your multi-mode controller, you may have had a problem with your transmitted audio signal being distorted, to eliminate this see bellow.

1. Set your meter on the radio to read ALC
2. PK232 OWNERS: if also using a VHF transceiver, adjust the AFSK level for proper VHF operation as explained in chapter 3 of the operating manual. If not adjust for proper SSB operation.

DSP - 1232 / DSP - 2232 Owners: Adjust the appropriate AFSK level control for proper SSB operation as explained in chapter 3 of the operating manual.

3. Place the TNC in calibrate mode and press K to key the radio.
4. Adjust VR-13 on the TS-450 or VR-18 on the TS-850 so that the meter "Just comes off the peg" as described in the section titled "SSB Tranciever Final Adjustments" (in the TNC operating manual).
5. Press Q to quit the CALIBRATE mode

This modification should not affect any of the other normal operations of the radio..

Copy of service bulletin from AEA

This modification is read 1276 times.

[top of page](#)

19-07-1998

(TS-450) TS-450 hidden functions

As users of the Kenwood TS-450S already known it is possible to configure the set to personal needs by hold down some buttons during Power on.

There are three buttons listed in the manual.

The menu of Power ON + LSB/USB is listed on page 54 from the manual

The menu of Power ON + M.IN is listed on page 55

The menu of Power ON + ENT is listed on page 83

As often usual in microprocessor controled equipment there are hidden keyboard combinations who make it possible to configure more functions then is listed in the manual.

At Power on + CLR + ENT a reset to factory defaults is taken place.

All memory programming is lost !

All filters are available (also these who are not fitted)

But there is something more!!

The receiver is able to receive from 30 kHz to 40 MHz

Transmitting is possible on

1620 kHz to 2000 kHz

3500 kHz to 4000 kHz

7000 kHz to 7500 kHz

10.0 MHz to 10.5 MHz

14.0 MHz to 14.5 MHz

18.0 MHz to 19.0 MHz

21.0 MHz to 21.5 MHz

24.5 MHz to 25.0 MHz

28.0 MHz to 30.0 MHz

Unfortunately after power off and switching on the programming is returned to the most of the old values, but the 100 memory places are still empty.

So one advice before start of experimenting note the contents of the memory places and configuration on a piece of paper, and read the "F" manual .

Until now I do not have a method to program the expanded receiving and transmitting frequencies into the TS-450S. If someone knows how to do this please let me know.

This modification is read 2092 times.

[top of page](#)

19-07-1998

(TS-450) TS-450S and KAM Plus info

Hi just found out a KINK in hooking up the TS450S to a KAM Plus for AMTOR op.

You have to turn ur Delay and CAR control to 0 to get it to work mode A.

Neither control should be active when running AMTOR LSB but they are, TRUST ME.

This modification is read 1238 times.

[top of page](#)

20-02-1999

(TS-450) Micro-input RFI modification TS450-TS690 Kenwood

By Pedro M.J. Wyns, RF- and biomedical-engineer.

History:

After buying a ts690 I got considerable trouble with the vox circuitry.

The Vox gain was always too high due to an excessive feedback resistance in the vox amplifier. Apparently a PCB-mounting failure as the schematic carried the right value. After correcting this problem I still got RF problems with nearby antennas, blocking the transmitter in TX.

Problem:

lack of decent RF-filtering on the micro-input circuitry.

Solution:

adding ferromagnetic cores and adjusting rc-filters on the IF-board.

Action:

remove the connectors on the right hand side of the IF board (underside transceiver front towards you). Unscrew the board and fold over to the left. Add 22 nF parallel to R282 1k on the micro entry close to Connector 6. Add 1nF parallel to C177 close to the IC-15 input. Add 1nF parallel to C217 close to the vox amplifier.

Remove the micro in and ground from the number 6 connector. Feed the white micro wire through a two hole ferrite core. Feed the inner conductor through a small ferrite core as well Reconnect...

If you might be using an MFJ (=major fucking junk) voice keyer, disconnect the shit-unshielded micro cable and replace by high quality twin balanced micro cable. Only use PTT, Mic and GND.

This concludes the mod. Don't even think of doing this without the service manual and some smd-practice.

Good Luck

Pedro M.J. Wyns

21-04-2000

(TS-450) TS-450/690 Calibration cable change

Author: Kenwood Communication, inc.

Service Bulletin no. 995 (11 May 1992)

The TS-450/690 may not calibrate properly against WWW (JJY) when using the calibration cable that is supplied with early versions of these sets, (serial numbers below 311xxxx) and when an antenna that is shorted for DC is used. A dipole with a balun is a prime example of a DC shorted wire. A minor circuit modification that adds a 100 pF isolation capacitor should also be performed. Please refer to the diagrams below for modification notes.

Parts required:

E37-0280-05	Calibration cable assembly	1 Ea.
CK73FCH1H101J	100 pF capacitor	1 Ea.

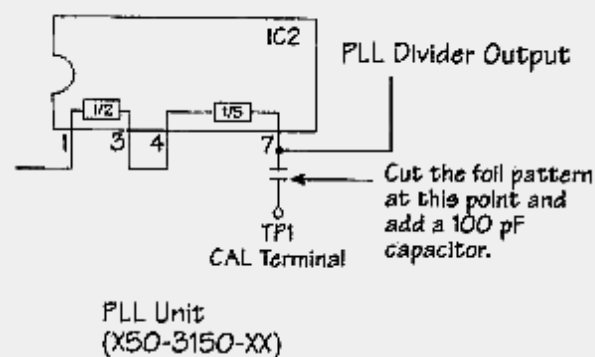
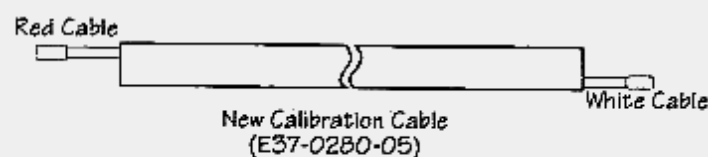

Time required for this modification is 30 minutes.

22-04-2000

(TS-450) TS-450/690 Distorted TX w/TNC

Author: Kenwood Communication, inc.

Service Bulletin no. 1002 (18 November 1992)

Note: This bulletin supercedes bulletin ASB-994, dated 10 April, 1992.

We have received several reports of distorted transmitter audio when using a TNC controller such as the AEA PK-232 or Kantronic KAM, etc. The symptom will generally disappear if the transceiver and TNC units are powered from different sources.

Cause:

The audio output level from the TNC is generally too high and causes overload of the microphone amplifier circuit. In previous models such as the TS-440S the incoming TNC audio was inserted after the microphone amplifier. With the TS-850S it is inserted before the microphone amplifier. Just moving the insertion point to the output of the circuit is satisfactory since the drive level for FM packet is higher than that required for SSB.

Procedure:

1. Add a 10 dB attenuator to the PKD line on the IF unit (X48-3090-XX). This will prevent overmodulation of the microphone input

circuit.

- a. Change chip resistor R233 from 10 Kohm to 18 Kohm (RK73FB2A183J)
- b. Change chip resistor R234 from 1 Kohm to 8.2 Kohm (RK73FB2A822J).
- c. Delete chip capacitor C173 (100 pF) and add chip resistor R299, 1.5 Kohm (RK73FB2A152J).

2. Add the following note to page 35 and 37 of the Instruction manual.

3. When adjusting for proper ALC levels with an AFSK RTTY terminal or Packet TNC terminal you should adjust VR-13 on the IF Unit for a reading similar to the one shown in the accompanying diagram.

Note: The transceiver and RTTY or TNC terminal should use separate power supplies, in order to prevent RFI (Radio Frequency Interference).

Caution: This modification requires soldering equipment rated for CMOS type circuits. It also requires familiarity with surface mount soldering techniques. If you do not have the proper equipment or knowledge do not attempt this modification yourself. Seek qualified assistance.

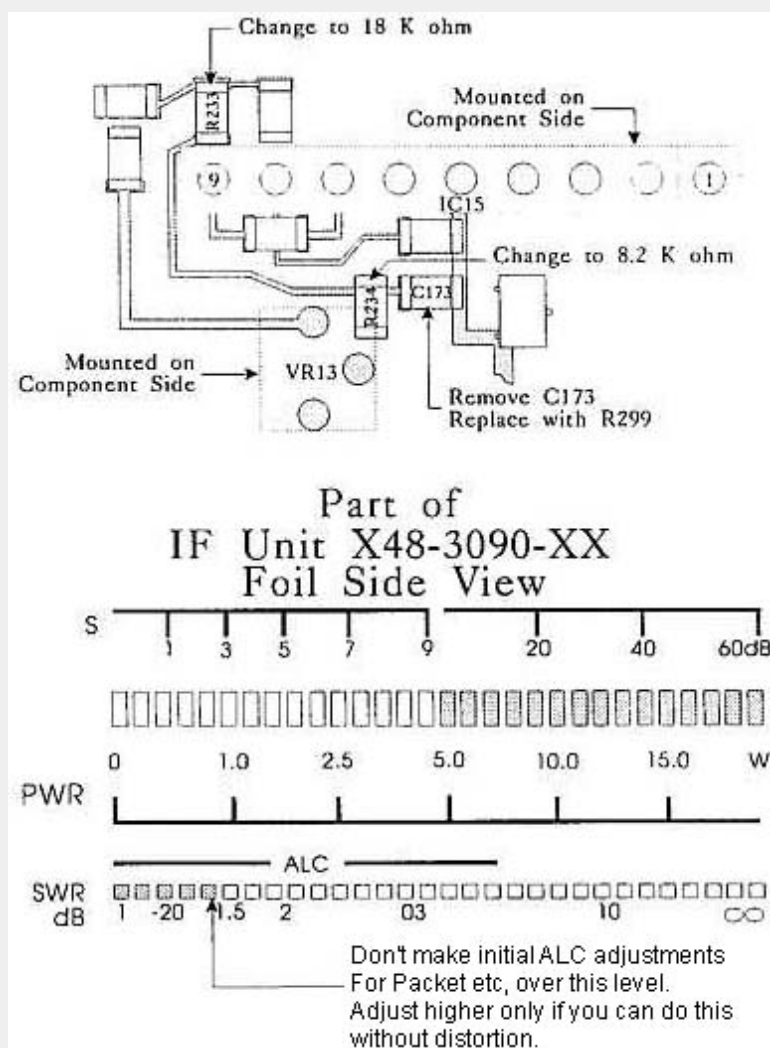

Time required for this modification is ½ hour or less.

This modification is read 1227 times.

[top of page](#)

22-04-2000

(TS-450) TS-450S TX frequency response

Author: Kenwood Communication, inc.

Service Bulletin no. 1004 (21 December 1992)

We have received several reports concerning the transmit audio quality of this unit. Several reporters noted that the signal sounded "hard" or had a reduced bandwidth, while others noted a difference in the noise quality when switching between USB and LSB. We noticed a significant difference between the output power in LSB and USB on some of these sets.

Cause:

Improper adjustment of the 8.83 MHz tuning coils (L73, L76) on the RF unit (X44-3130-00) can cause these symptoms. The coils have two tuning points. One is reached when the tuning slug project above the surface of the coil form. When tuned in this manner the bandwidth becomes narrow then normal and causes the symptoms noted above.

Alignment procedure:

1. Adjustment should be performed with the YK-88S1 (2.4 KHz) filter in line. If this filter is not preset you should select the THRU

position for the 8.83 MHz IF.

2. Adjust L73 and L76 according to the instructions provided in the service manual (Item 6 of the Receiver adjustment). Ensure that the slug are preset well down in the coil form, then adjust for peak. You should reach this point before the top of the slug exist the coil form.
3. Next, readjust L74 and L75 (Item 8 of the Receiver adjustment).
 - a. Select the 6 KHz filter for both the 8.83 MHz IF and the 455 KHz IF.
 - b. Select a dial frequency of 14.100.4 MHz.
 - c. Select the USB mode.
 - d. Adjust L74 and L75 for maximum.
 - e. Select the LSB mode.
 - f. Readjust L74 and L75 for maximum.
 - g. Repeat steps 3c - 3f several times until you obtain a difference of 2 dB or less in the AF output when switching between USB and LSB.
4. Check Item 14, CAR point adjustment (Transmitter section) Menu items 11 and 12, and confirm that the transmitter power is equal for USB and LSB.

Time required for this modification is 30 minutes or less.

This modification is read 1529 times.

[top of page](#)

23-04-2000

(TS-450) TS-450/690 Low mic gain w/DSP-100

Author: Kenwood Communication, inc.

Service Bulletin no. 1032 (9 August 1993)

Symptom:

Proper microphone gain/ALC readings cannot be obtained unless the user adjusts the TX GAIN potentiometer on the rear of the DSP-100. This irregularity is caused of the DSP-100 MIC amplifier (IC-5).

Corrective action:

Remove capacitor C200 from the IF unit on the transceiver, and replace it with R300, a chip jumper wire.

Parts required:

Qty	Description	Kenwood Part No.	Circuit description
1	Chip jumper	R92-0670-05	R300

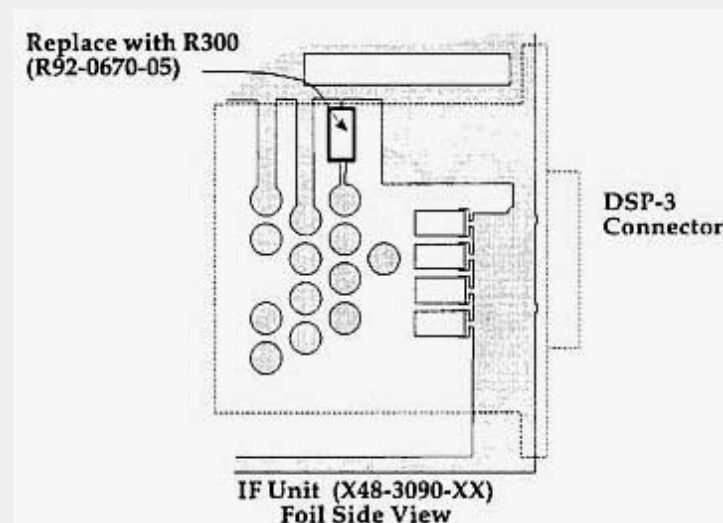

Caution: This modification requires soldering equipment rated for CMOS type circuits. It also requires familiarity with surface mount soldering techniques. If you do not have the proper equipment or knowledge do not attempt this modification yourself. Seek qualified assistance.

Time required for this modification is 1 hour or less.

This modification is read 1274 times.

[top of page](#)

23-04-2000

(TS-450) TS-450S Parts change

Author: Kenwood Communication, inc.

Service Bulletin no. 1036 (8 December 1993)

The 2SC2509 driver transistor are no longer available. They have been discontinued by the manufacturer. A substitute transistor (2SC3133) is available but requires some minor circuit changes. These changes are detailed below.

Parts required:

Qty	Description	Kenwood Part No.	Circuit description
2	Driver transistor	2SC3133	Q2, Q3
2	330 ohm 1 watt carbon resistor	RC05GF2H331J	R8, R9
1	.047 μ F ceramic capacitor	C91-0119-05	C2
2	220 pF ceramic capacitor	CC45SL2H221J	C64, C65
1	560 pF ceramic capacitor	CC45SL2H561J	C63

Note: C64 and C65 should be soldered directly to the collector and emitter pins of the final transistor Q4 and Q5.

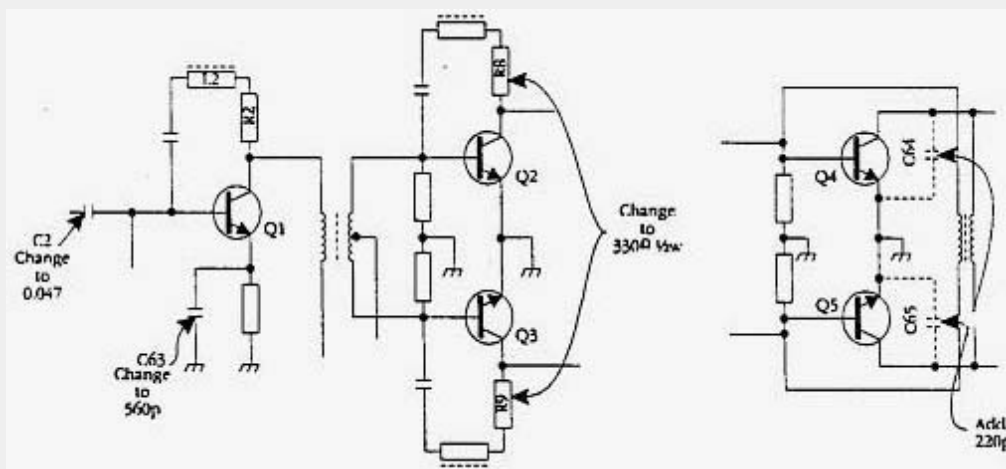

Time required for this modification is 60 minutes or less.

This modification is read 1495 times.

[top of page](#)

23-04-2000

(TS-450) TS-450S/690S Noisy encoder

Author: Kenwood Communication, inc.

Service Bulletin no. 1059 (7 July 1994)

Symptom:

When tuning the Main Encoder of the TS-450S/690S with bare hands you may encounter a "scratching" noise in the speaker if an antenna with a high SWR is used. If gloves are worn no problem is encountered. This occurs because the shaft of the encoder is not grounded.

Countermeasure: Replace the Main Encoder with one that has a grounded shaft.

Parts required:

Qty	Description	Part No.
1	Main encoder	W02-1836-05
2	Mounting screws	N90-3006-46

Note: You must use the new mounting screws listed above with the replacement encoder.

Time required for this modification is 30 minutes or less.

This modification is read 1298 times.

[top of page](#)

19-07-1998

(TS-50) TS50 FIX: LCD display dark

From: DJ7UA @ DB0QS.#NRW.DEU.EU (Mario)

Problem:
No display illumination, LEDs On Air, AT TUNE no function The menu item 2 has no effect, display keeps always dark.
All other functions normal.

Possible reason:
Bad contact LCD Assy for 5V line to R9, R10 and IC5.
Power on the TS50 and check voltage at R9/R10.
If voltage is 0V, but display readout is active, the reason might be as discribed.

Measurement to fix it:
Look for the small hole near R9 at the LCD Assy, component side view, where the contact between the two sides of the LCD Assy is located.

If you have no service manual:
This is the side oriented to the front side of the device.
R9/R10 are located close to the two LEDs.
Take a small size needle to pick through the contact hole to encrease the diameter.
Make a contact between the two layers by soldering a piece of wire across the hole.
Check the 5V at R9/R10.

73, Mario
DJ7UA

This modification is read 2268 times.

[top of page](#)

19-07-1998

(TS-50) TS50<-->AT50 communication

```
+-----+
|   TS-50 <--> AT-50   Communication   |
+-----+
|   as measured/discovered by DF6KR    |
|   No guarantee for whatsoever....    |
+-----+
```

Communication method: Serial interface
Transfer rate: 4800 bps
Synchronization: Start-stop (Asynchronous)
Parity: None
Signal format: TTL level (!)

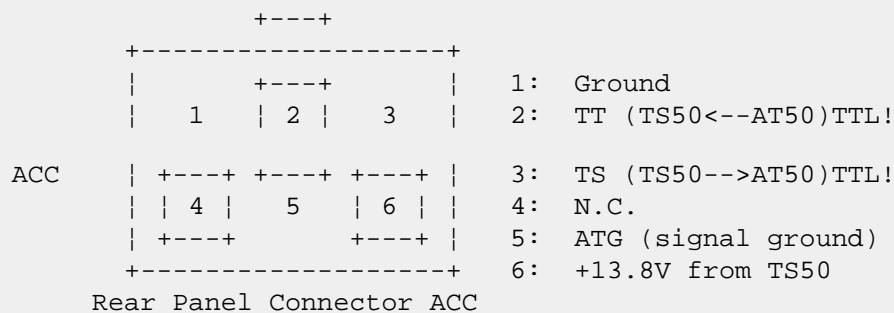

Timing:

1. at Power-on:

=====

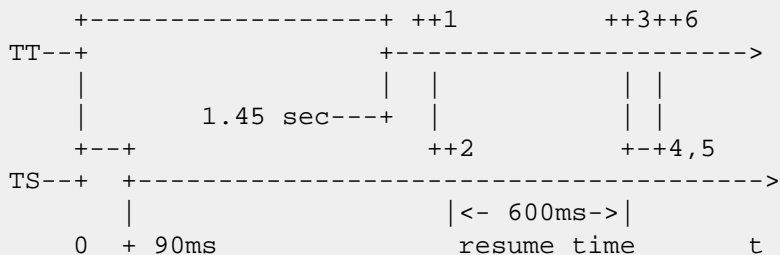

Signal:

```

1          3          6
TT: ;;;;0C;___0D01;_____0F11;
          2          4          5
TS: _____0C;_____0D01;0F11;_____
```

```
1: Power on comm.
2: Power on answer
3: Auto on request
4: Auto resume finished
5: ok at50
6: ok answer ts50
```

```
2. DOWN-UP-Communication
=====
```

```
TT: 0E02;_____0F11;___ - UP from 1.8 to 3.5
TS: _____0E02;0F11;_____
```

```
same:
```

```
0E04;0E04;0F11;0F11;   UP 3.5 --> 7
0E05;0E05;0F11;0F11;   UP 7   --> 10
0E06;0E06;0F11;0F11;   UP 10  --> 14
0E07;0E07;0F11;0F11;   UP 14  --> 18
0E08;0E08;0F11;0F11;   UP 18  --> 21
0E09;0E09;0F11;0F11;   UP 21  --> 24.5
0E0B;0E0B;0F11;0F11;   UP 24.5--> 28
0E0C;0E0C;0F11;0F11;   UP 28  --> 29
0E01;0E01;0F11;0F11;   UP 29  --> 1.8
```

```
DOWNs
```

```
0E0C;0E0C;0F11;0F11;
0E0B;0E0B;0F11;0F11;
.
.
0E01;0E01;0F11;0F11;
```

```
TUNE:           0D03;0D03;0F41;0F41;
AUTO OFF (THRU): 0D00;0D00;
AUTO ON:        0D01;0D01;
tune error:     0d03;0d03;0F83;0F83;
```

This modification is read 2183 times.

[top of page](#)

19-07-1998

(TS-50) TS-50 Power Mod for QRP

"Honey - I Shrunk the Rig"
by Bob Gobrck WA6ERB

No this is not an article about Kenwood shrinking their new TS-50 HF rig into a "CB" sized package, but the "shrinking" of the low power level on the TS-50 from 10 watts to 5 watts output in order to "officially" comply with the nationally recognized QRP power level for contest operation.

Prepare yourself before you remove any covers from the TS-50 - this is no Hallicrafters (feel a little dated) with 6L6's glowing in the inside. All components are surface mounted and to conserve space surface mounted subassemblies stand up at right angles all over the place. No place to work with that stubby tipped Weller soldering gun. But have no fear, this QRP mod is simple - you just need a screwdriver with a blade the size of a toothpick.

If you check the schematics you will see on the TX/RX board two potentiometers to set the Low 10 watt (pot VR15) and Medium 50 watt (pot VR16) power levels. The high power level is fixed at 100 watts by resistor R214. Our goal is to get to VR15 and set it for a 5 watt output.

First remove the top cover, set aside speaker and remove the latched speaker bracket (gives you better operating room). Locate two teeny-weeny pots next to IF filter module in the middle of the TX/RX board. The pot closest to the front panel is VR15 (low power adjust) and the one closest to the back of the rig is VR16 (medium power adjust) - the pots are somewhat marked on the PC board. Hook up a QRP wattmeter, dummy load and power and while in th low power mode adjust the pot (I used a flat blade calibration tool I had around) for 5 watts. That's it. You may notice that you can crank the pot all the way down to 0 watts so set where you want. I suspect the medium power adjustment with VR16 can also go to zero so maybe you can go QRPP by setting the low power pot for 999 mw and the medium power pot for 5 watt.

PS: Kenwood Service cautioned that their automatic antenna tuner requires 10 watts to actuate so this adjustment may affect that operation. You may want to check if Kenwood actuates the low power mode when the antenna Tune button is pressed. Also don't expect to run this rig off of a small solar cell for field day - the unit and all of it's surface mounted components draws a bit of power - enough for the internal fan to come on even in the QRP low power mode.

This modification is read 2316 times.

[top of page](#)

19-07-1998

(TS-50) TX Coverage mod TS-50

Hi folks,

I just got a spanking new Kenwood TS-50S.

Searching around the local LLBBS's I found a very simple mod for full transmit from 1.7 - 30 mhz....

Remove the bottom cover of the TS-50

Locate the PLL board -- it is the pc board on top of the main board, it has a shield on it's right side.

Locate the only non-surface mounted component on the PLL board -- look near the rear left-hand side of the pll board (front of radio facing you) and remove the very obvious diode. You can't miss, ther's only one.



Replace cover.

Perform microprocessor reset as described in your manual.

This modification is read 3039 times.

[top of page](#)

23-01-1999

(TS-50) CAT control for TS-50S

From: 9A2NX@9A0YKZ.HRV.EU

I wish to offer an cheap solution for solid work with CAT control with your transceiver Kenwood TS-50S and PC. After long examinations and testing.

I found out following solutions as most acceptable:

1. Interface IF-10D (227DM) and serial interface RS-232C (283DM) with program.
2. Interface IF-10D, line DIN6P connector and DB9 for PC (COM1), 2 germanium diodes, 2 condensators 10nF, which acts as RS-232C !
3. Small home made interface, in SMD technology, on the PCB 2x3 cm, integrate with TS-50S on the lower side of its PCB. The connecting line with PC can be home made. This can be done by specialists which can achieve an cheap solution.

The most convenient solution is mentioned under 2. Software is selected between 40 different solutions. The best one that made by N3EQF, RIG-EQF ver. 1.02. He is well known author for LOG-EQF software. This software is produced for TS-940S ?, but it works OK with TS-50S. The program runs after command RIG-EQF 1, for COM1 and RIG-EQF 2, for COM2. I tested program on laptop T2200SX25 and on PC 80386DX40.

The program is easy to use, with simple commands. The program can be activated only if all his hardware is on, interface, PC and TS-50S. When the program is active the working frquency is displayed, very precisely registering each change, then RIT control, modulation, VFO A and B, SPLIT etc.

Option O has possibility to input 22 different QRGs, modulations, descriptions and call sigs. Then you can choose any of them with cursor.

With key P is possible to obtain scanning of frequency in the wished range, then step raster and speed.

The second program, witch works the same things, but in little bit reduced range, is KEN-AE6G, dated 1990. it has VFO A and B control, and M memmory control. It is intended for use with TS-440 and TS-940s!

I include the plan of connection for IF-10D to DB9 pin PC port. The software can be downloaded from BBS and programs are very well sorted on FBBS of IV3LAV-8 via IR3GO (gonode). Using yapp protocol all can be quickly downloaded from subfolder RTX. Names are RIG-EQF.ZIP 71.005 bytes, and TS50.ZIP - 6.847 byta. Detail description, schemas and know-how will be published in "Radio

HRS", edition of 9A union.

On my TS-50S I tried the work with 2 computers: laptop worked with CAT-control, while PC 386 worked with SSTV (Hi)! The work was stable.

I wish to all CAT enthusiasts a lot of pleasure.

Vy 73 de IKO-9a2nx@9a0y kz.hrv.eu !

Connection "home made" cable to IF-10D to PC:

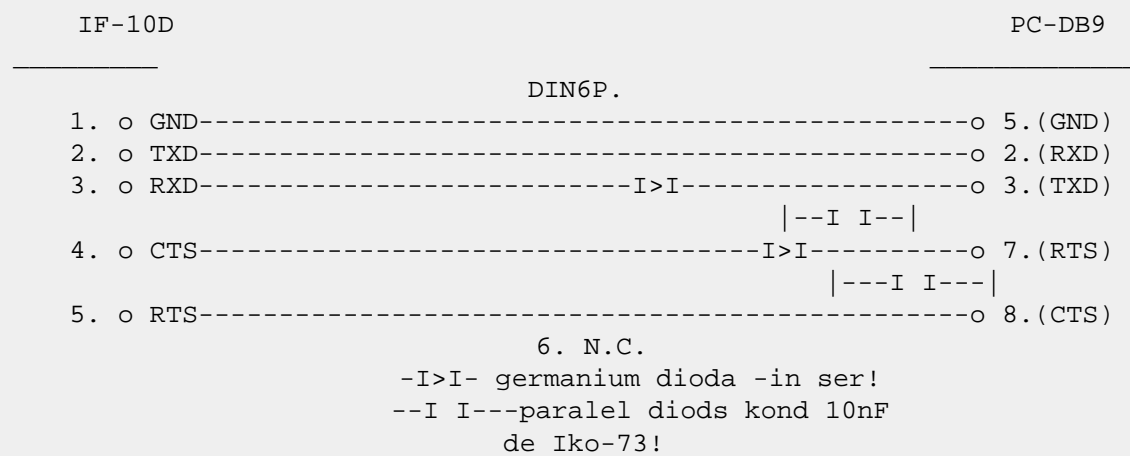

This modification is read 2258 times.

[top of page](#)

14-02-1999

(TS-50) Important note to 0-30 MHz TRX mods

If you want to make your TS50 tranceiving 0-30 and find more then 1 diode in your radio, PLZ watch out! Dnt remove diode nr1! Remove nr5.

If you remove diode nr1 your radio is history!

This modification is read 2722 times.

[top of page](#)

19-01-2000

(TS-50) New version. General TX for TS-50

The new version of the TS 50 has three non surface mount diodes to be cut for general TX.

This modification is read 2576 times.

[top of page](#)

22-04-2000

(TS-50) TS-50S Lithium battery replacement notes

Author: Kenwood Communication, inc.

Service Bulletin no. 1015 (10 May 1993)

Procedure:

Immediately after replacing the Lithium battery you must cycle the radio ON then OFF. Failure to follow this procedure will result in premature failure of the battery. If the power is not cycled ON then OFF the microprocessor will immediately begin drawing approximately 1 mA of power from the Lithium battery, resulting in poor battery life.

When the battery is replaced we recommend the insulation sheet also be changed. Part numbers for the battery and insulation sheet follow.

Parts required:

Qty	Description	Kenwood Part No.	Circuit description
1	Lithium battery	W09-0515-05	BA1
1	Insulating sheet	F20-0521-04	--

Caution: This modification requires soldering equipment rated for CMOS type circuits. It also requires familiarity with surface mount soldering techniques. If you do not have the proper equipment or knowledge do not attempt this modification yourself. Seek qualified

assistance.

Time required for this modification is 15 minutes or less.

This modification is read 2071 times.

[top of page](#)

23-04-2000

(TS-50) TS-50S "Hello" displayed during TX

Author: Kenwood Communication, inc.

Service Bulletin no. 1030 (29 June 1993)

Symptom:

Occasionally an "Hello" message will appear in the display of the transceiver when the TS-50S is loaded into a antenna without the use of an antenna tuner. This symptom usually occurs when the negative terminal of the power supply is floating (un-grounded for RF). This can result in RF feedback that causes the supply voltage to exceed to 16 Vdc.

Corrective action:

1. Cut the Final Unit PC Board foil in two places, as shown below.
2. Add a .01 μ F chip capacitor (C125) as shown below.
3. Add a 10 μ H chip Ferri-inductor (L102) as shown below.
4. Add an insulated jumper wire as shown below.

Parts required:

Qty	Description	Kenwood Part No.	Circuit description
1	.1 μ F chip capacitor	CK73EB1E104K	C125
1	10 μ H Ferri-inductor	L40-1001-48	L102

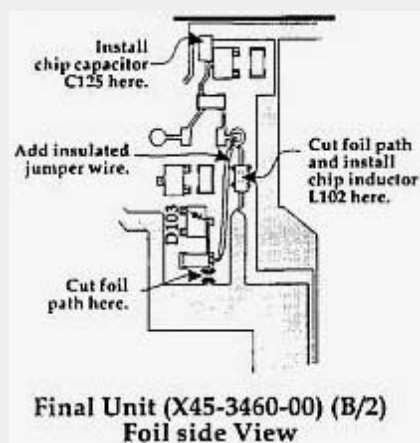

Caution: This modification requires soldering equipment rated for CMOS type circuits. It also requires familiarity with surface mount soldering techniques. If you do not have the proper equipment or knowledge do not attempt this modification yourself. Seek qualified assistance.

Time required for this modification is 30 minutes or less.

This modification is read 2276 times.

[top of page](#)

23-04-2000

(TS-50) TS-50S Antenna lead wire

Author: Kenwood Communication, inc.

Service Bulletin no. 1035 (7 December 1993)

Symptom:

Several users have reported a problem with the antenna lead connection, i.e. the lead that connects the antenna connector to the Filter unit (X53-3120-xx). Originally this connection was made by a zero ohm resistor. If excessive stress is placed on the antenna connector this lead is easily broken, with a resulting loss of receiver sensitivity and transmitter power. The use of a small flexible jumper wire will increase the flexibility of this connection, thus minimizing the effect of mechanical stress.

Parts required:

Qty	Description	New part No.	Circuit description
1	Cable	E37-0445-05	W2

Procedure:

Remove the zero ohm resistor and replace it with the small piece of cable. See accompanying diagram.

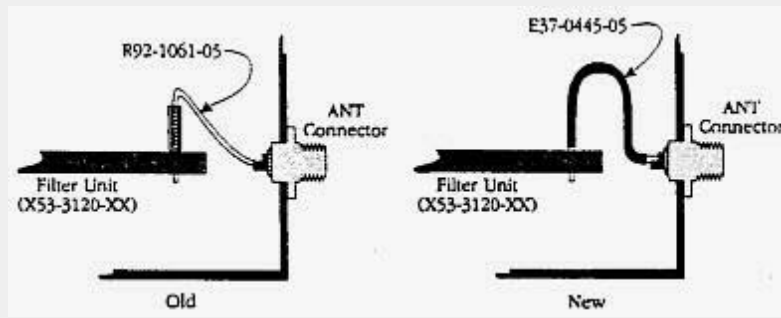

Caution: This modification requires soldering equipment rated for CMOS type circuits. It also requires familiarity with surface mount soldering techniques. If you do not have the proper equipment or knowledge do not attempt this modification yourself. Seek qualified assistance from your closest Kenwood Service Center (Long Beach, CA, or Virginia Beach, VA).

Time required for this modification is 30 minutes or less.

This modification is read 2232 times.

[top of page](#)

23-04-2000

(TS-50) TS-50S Mechanical noise from final unit

Author: Kenwood Communication, inc.

Service Bulletin no. 1044 (28 March 1994)

Symptom:

When the transceiver is subjected to vibration a mechanical noise can be heard from the output transformer area. This has led to concern by several consumers that something is loose or improperly installed.

Corrective Action:

In order to ease consumer concern toy should add a cushion under transformer L4 as shown in the accompanying diagram, and replace transformer L13 at the same time. This transformer has been fastened to the circuit board with high temperature adhesive, so use caution when removing it from the circuit board.

Parts required:

Qty	Description	Old part No.	New Part No	Circuit Description
1	Cushion	NA	G13-0871-04	(Under L4)
1	Output transformer	L39-1209-25	L39-1252-05	L13

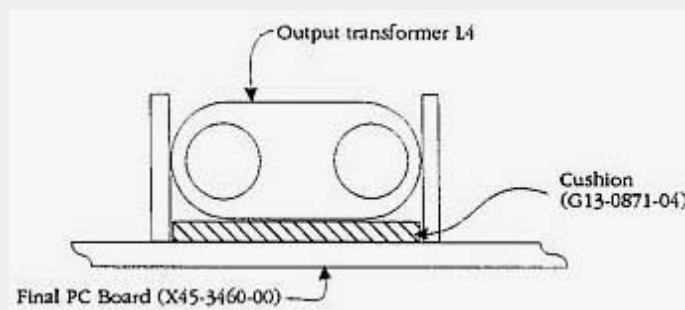

Time required for this modification is 30 minutes or less.

This modification is read 1982 times.

[top of page](#)

27-01-2001

(TS-50) TS-50 Modification Full time "Double-Zero"

Author: Chris Arnold - carnold@mericom.com.MODIFICATION.NET

This modification makes the "double zero" display full time.)

1. Turn on radio
2. Go to MENU 'B', item #70.
3. Program [85] into item 70. This puts the 'double-zero' on the #4 (PF4) button on the microphone. Press the F-LOCK to get out of the menu function.
4. Press 'F-LOCK' [ON].
5. Press and hold PF4 button on mic.
6. While holding PF4 button down on the mic, press and hold the [SPLIT] button.
7. Release the PF4 button -then- release the SPLIT button.
8. Turn F-LOCK [off].
9. Go back to MENU 'B', item '70', and remove [85] or change the number.

This modification is read 2434 times.

[top of page](#)

16-06-2001

(TS-50) TX 0-30 MHz for the new TS-50 (May 2001)

Author: - jack84@xs4all.nl.MODIFICATION.NET

ON the new version are 4 diode on de board.

Cut remove all, D1 D3 D4 D5

Then RESET the Kenwood TS-50

This modification is read 2814 times.

[top of page](#)

08-08-2001

(TS-50) TS-50 High-Power-Modification

Author: Joe, DL6IB - info@dl6ib.de.MODIFICATION.NET

As the most of you TS-50-Users surely know, it is possible to increase the Medium-Power, the Low-Power but not the High-Power-Setting. Reason: There is no Trim-Pot, it is a small SMD-Resistor. With that small Modification you'll get a Trim-Pot and the TS-50 is able to run up to 180 W output without any problems.

1. Remove Top-Cover and hook out the internal speaker. Place the rig top up, display to you. The area you need is closed to the left side of the CW-Filter-Board on the main-RF-Board, where the Filter-Board is screwed on.
On the board is printed on 'PL', 'PM', 'PH' and an arrow. Above are two pots and two little black chips, the right one (SMD-Resistor) is very closed to the second pot.
2. Remove this SMD-Resistor (R214, 10k), wich is located closed above the two pots for Med and Low. It is a VERY small black chip, marked with '103'. Be CAREFULL while soldering!!
3. Make yourselfe a small Board, 25 mm long, 8-10 mm wide. At one end drill a centered 3mm-hole closed to the edge of the board.
4. Solder one konventional 4k7-Resitor (standing, a 5k6 or 6k8 also can do it) and a konventional 10k-Trim-Pot (lying) in serial order on this board.
Make sure, you make no shorts and build the circuit as narrow as possible and very closed to the reverse end, from where you drilled the hole in - you later need 10mm space at the drilled end!

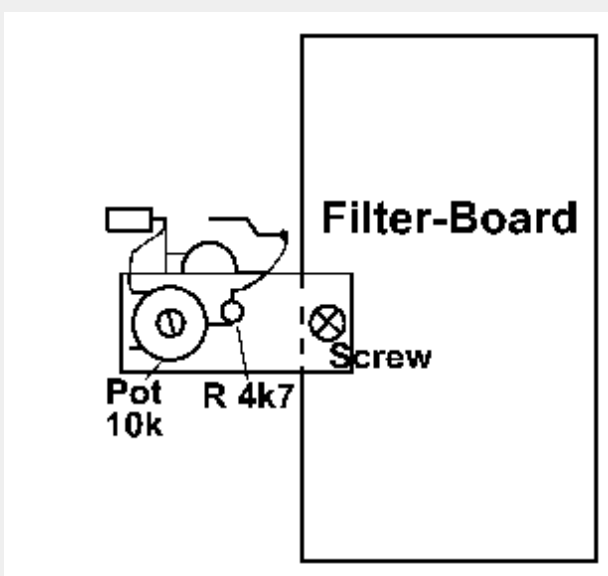

5. Connect two two fine wires (length aprox. 20 mm) at the ends of this little circuit and solder it (CAREFULLY!!) to the free solder-joints of the resistor. To make it a bit easier: the right one you can solder to a joint about 4mm away of it - just follow the small trace to the right and you will find this lonesome contact.
6. Remove the screw of the CW-Filter-Board, place your little board hole-on-hole on top of the Filter-Board and Re-Screw the two boards together to the main-board. So your little "Tuning-Unit" is fixed, hanging above the Med- and Low-pot.
7. Connect the rig to a power-supply (25-30 Amps!), a power-meter, a dummy-load and switch it on. No smoke? So you might have done everything all right ;-)
8. Push a FM-Carrier on 14Mhz and set the 'new' pot on the desired output. My TS-50 can do max 185 Watts but I have adjustet it to 150-160, so it modulates fine 130 Watts SSB with the original mike - what a difference to that 70 before... Don't adjust it to high, think about your finals and filters!

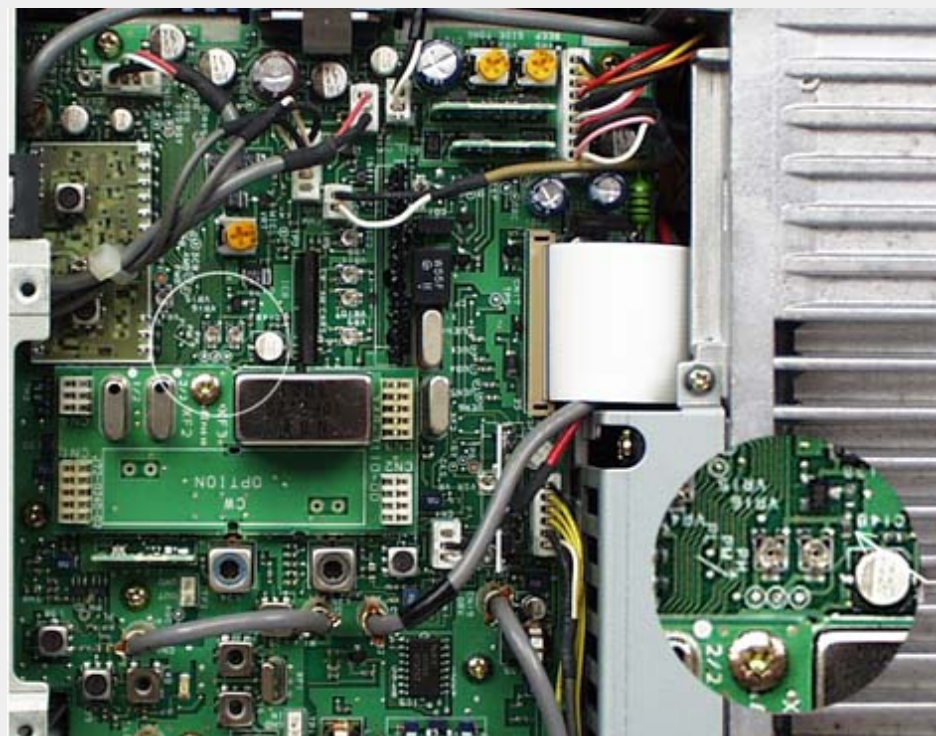
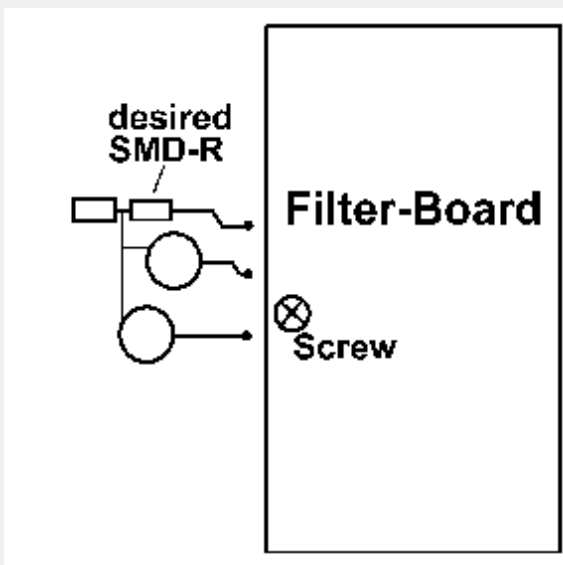

Thanks to [Jim Duarte](#) for this photo.

Note: You are making this Mod on your own risk, I am NOT responsible!

Good luck, 73's
Joe, DL6IB
www.dl6ib.de
info@dl6ib.de

This modification is read 3419 times.

[top of page](#)

12-10-2001

(TS-50) Kenwood TS-50S Wideband TX & double zero readout

Author: Gerry - gi0zgb@lineone.net. MODIFICATION.NET

I purchased a new TS-50S in May 2001, to enable Wideband TX cut D3 & D4 on the digital unit X46 - 315X - XX.

I purchased another new TS-50S today 10/10/2001 the mod is the same except cut D5 as well to enable.

Enable this mod entirely at your own risk and responsibility.

Note; enabling the double zero mod you will lose the RIT display, it's activation is now indicated by a beep. To reverse enable a partial reset by holding down A/B and switch on, or, retain the 70/85 key 4 mic setting and normal function will resume at a key press.

73 Gerry.

This modification is read 2507 times.

[top of page](#)

10-03-2002

(TS-50) TS-50S Australian Extended Tx

Author: - vk2ezq@winlink.org. MODIFICATION.NET

Tx mod for TS-50S originally from Sydney, Australia in 1995.

Review the mod in www.mods.dk where the coloured picture of the control board is provided. This shows a picture of D5. The pads for D1 through D5 are obvious on the control board which is piggy backed on the PLL board with 2 multipin sockets and 2 screws. This radio only had D4 obvious - snipping it did not do the job. D1, D2 and D3 were not fitted. (D5 not fitted next to D4 - see below)

Disconnect the power.

Ground the radio and keep one hand on the metal work or use a wrist strap to ground yourself. Locate the Control Board as it says in the Instruction Manual for "Options Installation" and "TCXO UNIT (SO-2)".

Remove the control board as it says in the book.

The 3 plugs are not as such plugs - the catch bar releases the ribbon cable and is easy to push apart but a bit fiddly to get back in. 3 hands might be needed and you have to push the bar down as well as in. Very little force is needed. Do not force it - if it wont go in then you have not got the right angle.

The 2 screws required the use of a special tool which was not available. A fine pointed set of side cutter wire snips can be used to tightly grip the round headed screws by the dimples.

Suggest you locate the 2 white plug/sockets visually by looking under the Control Board before you pull off the Control board from the PLL board so that you dont bend the pins since it has to go strait up at both ends.

Under the board (under D5) was found what looked like a blob of opaque glue about 4mm diameter. Under this glue could be seen a black speck. The glue was levered off and a Surface Mount diode came off with it - breaking away from the PCB track. Diode about 1.5*1mm. Obviously this blob was doing the function of D5 which was pictured in mods.dk

A full "Microprocessor Reset" as it says in the Instruction Book gave the desired result.

Other changes were also successfull.

See instruction manual "MENU SET-UP"

USB below 10MHz - alter Memory location A04 from "SSB" to "ULC".

Double Zero on frequency display - put "85" into memory B70 instead of "82".

Note also the mod in mods.dk which explains what to do if the memory battery is changed or disconnected. On replacement of the memory battery you have to cycle the radio on and then immediately off otherwise the memory battery drain is 1mA and it will go flat very quickly.

PS WANTED: Does anyone know of a mod to make the Kenwood TS-50S radio switch on with the Low power option setting set. Altering Memory A00 to 10 does not do this. The radio switches on in the power setting you last used it in, which is not good for manual tuning if that happened to be high power.

This modification is read 323 times.

[top of page](#)

19-07-1998

(TS-520) TS-520, TS-820 CW filter select control

Author: Trio-Kenwood Communication, inc.

Service Bulletin no. 812 (14-2-1980)

In the TS-520SE, the Heater Switch has been replaced with a CW WIDE/NARROW select switch. For those operators who desire this type feature for their transceiver, the following information may be considered as a guideline.

TS-520S series transceivers

1. A miniature SPDT switch may be installed at the operators preference, on the rear side, or bottom panel. Use this to switch the CW or SSB filters by wiring the BROWN lead, which normally is transferred to the CW terminal on the IF unit, between the SSB filter, for WIDE, and CW for NARROW.
2. A Traditional solution has been to use the FIX CH switch, position 3 and 4 for filter switching. This may be done by completely rewiring the switch, or by leaving the switch wiring and the filter wiring as for normal operation, and bridging the following terminals:

A. FIX CH C terminal to IF SSB Terminal

B. FIX CH 4 terminal to IF CW terminal

Placing the FIX CH switch to 4 will operate the SSB filter in CW mode.

TS-820S Series Transceivers

1. Similar to the TS-520 series, a miniature SPDT toggle switch may be installed at the operators preference at the rear or on the bottom cover.
2. The FIX CH switch, or Digital Hold switch may be rewired to control the CW wide/narrow function

On the MODE switch, S6-1, the SSB filter control is GREEN, and the CW filter control line is GREY. Break the GREY line and connect it from the MODE switch to the SPDT common terminal. Connect the GREY line to the IF unit at one terminal, and bridge the GREEN SSB line to the other Switch terminal.

This modification is read 1159 times.

[top of page](#)

19-07-1998

(TS-520) DG-5 Standard Service Procedure

(Supplement to the DG-5 Service Manual)

Introduction

A majority of DG-1 failures are caused by nothing more than an intermittent opening of a plated-through hole connecting top and bottom foil paths of the PC board.

Before any component level service is attempted, it is advisable to eliminate the possibility of an intermittent connection causing or complicating counter failure.

Procedure:

1. Disconnect all cables.
2. Remove cabinet: 2 screws at the rear, 2 screws with star washers on the bottom.
3. Disassemble display from chassis; 4 countersunk screws on the side rails.
4. The display unit has 2 through holes without leads, and the Counter main board has 82 through holes without leads passing through them. Ideal service would be to first remove all solder from these holes using vacuum desoldering devices, or WIK-IT braid. Then, pass a length of #24 tinned bare wire into each clean through hole, solder, and clip flush. For 10 holes listed under IC's solder sparingly so as not to create a solder bridge under the component. For the remaining 72 holes, inspect each "pinned" connection from both sides to ensure (1) no bridge and (2) a good solder joint.
5. Wash the display to counter Board PC board connectors (male and female) with FRESH trichlorethylene. Heat dry and inspect for flux residue. Spray the connectors with silicone.

6. Similarly, clean and coat the rear panel RCA jacks as in step 5.
7. Reassemble, reversing steps 3,2,1.

How to solder on the DG-5 pc board.

1. Use a low power pencil iron of 35 watts or less.
2. Use rosin core solder, small diameter.
3. Do Not create solder bridges or splotches.
4. Do Not overheat or otherwise lift the foil from the board.
5. Wash excess flux away with FRESH trichlor, and a small flux brush.

Neatness counts - it's your radio.

Through Hole Accounting

Display unit - 2
 Counter unit -82
 Total -84

Locations:

- A. Under; IC2,4,13,20-25,34, 1 each
 Total 10
- B. Adjacent or between; IC3,13-14,15-16,22-23 1 1 each
 IC1-2,6,18 2 each
 IC12 3 each
 Total 13
- C. Located between rows: IC13-18,20-25 - 5
 20-25, 26-31 - 10
 IC26-31, 32-37 - 15
 IC32-37, 38-39 - 25
 Total 55
- D. At rear panel: FS7805 regulator - 1
 2SD235 transistor- 3
 Total 4
- E. Display unit - 2

Additional Ponto

1. R126 &129 are power resistors located at the left rear corner of the PCB. Remove the tubing from their outside legs and resolder each lead to the top foil path. Specific symptom for this failure is no display, and no decimals.
2. For counters which roll, random count, or inject hash noise back into the TS-520/520S especially when hot, install an additional .1uF @ 12v bypass cap across the FS7805 regulator on the foil side of the PCB from the center ground lead to the outside leg, across C89.
3. For complaints of hum or digital noise from the DG-5 back into the TS- 520/s both during RX and TX, tighten the mounting screws which supply ground to the Carrier unit X50-0009-01 in the transceiver.

Please annotate your service manual.

This modification is read 1176 times.

[top of page](#)

19-07-1998

(TS-520) Service notes on TS-520

Author: Trio-Kenwood Communication, inc.

Service bulletin no. 21 (21-10-1977)

Transmitter

1. No switching of final relay: Bad Q8 on X54-0001-00 2SA562Y.
2. No drive: C3 100pf in final box is cold soldered.
3. Low output: Check the plate load cap for touching plates.
4. 3.5 MHz low output: Replace burned 47pf 3KV at load wafer.
5. No TX: Final choke burned out in final VOX L8.
6. No RX or TX: Bad common amp. Q1 3SK35GR in IF unit X48-1060-00.
7. No ACC: No plate current Q2 3SK41 If unit X48-1060-00.

8. No TX relay: Q8 2SA562Y on VOX unit. Also R18 1K resistor relay control.
9. No TX or RX: Check 9 volt terminal on FIX AVR (X43-1100-00) is loose.
10. No CW TX: Bad 9 volt regulator. Check D3 WZ061 on X43-1100-00.
11. No TX: Solder touch between TIF and key terminal on X44-1080-00.
12. No drive to TX: Check RL1 on GEN unit, small reed relay (X52-0010-01).
13. No ALC meter action on 10 meters: This is normal for TS-520.
14. CW chirp: Q4 2SA606L on Fix channel AVR X43-1100-00.
15. ALC meter to maximum when TX: RFI terminal at X44-1080-00 is not soldered.
16. No TX output: 82pf 3KV in final is burned.
17. No TX output: Q3 on RF unit 3SK41 X44-1080-00.
18. No bias: 10 ohm cathode resistors burned in final VOX.
19. No drive or TX output: R70-71 RF unit, R5 Rectifier unit.
20. No VOX: Q8 in VOX unit X54-0001-00.
21. No TX: 12BY7 is bad. Shorts and burns out. R71 and 70.
22. No carrier output: Q1 on Carrier X50-0009-01.
23. No drive - no screen voltage: R5 470 ohm open on rectifier X43-1090-00.
24. No drive - no ALC: Q2 3SK35Y IF unit. Q3 3SK41L RF unit.
25. No RF output: C13 0.04uf at pin 1 of S2001A is bad.
26. Low mic gain: Q1 2SC1000 on Gen unit.
27. No TX: Misconnection of brown wire after installation of CW filter.

Receiver

1. Low Sensitivity: Touching RLT and 9V at function switch.
2. Receiver sensitivity: No -6v at AVR: Q8 2SC735 on X43-1100-00 is bad.
3. Frequency Shift: Bad carrier Xtal 3395 on carrier unit.
4. VFO drift: C6 22pf, VFO unit.
5. No receive: Bad Q4, 3rd IF amp 3SK35GR on X48-1060-00.
6. Receiver sensitivity and bias current jump, -6v unstable: T1 oscillator transformer for -6v is bad on X43-1100-00.
7. Erratic AGC action: C11 100uf 16V on X431100-00. Fix channel AVR is bad.
8. Frequency shift when warmed up: Q1 in VFO 3SK22GR.
9. No RX or TX: If unit C59 touch to T12 IF transformer.
10. Receiver noise: Q5 3SK35Y X44-1080-00.
11. Receiver sensitivity down: NBI terminal is pulled loose. Receiver at IF board.
12. No S meter reading and RF gain CCW. No meter deflection: Q3 on IF unit. Q5 on RF unit.
13. VFO frequency jumped: There is loose tension inside VFO.
14. VFO frequency shift: Cold solder of VFO output lead to VFO output socket.
15. Blows fuse when first on: Check Q1 and Q2 DC-DC converter transistor. One is possibly shorted.
16. Noise blanker inoperative: R6 4.7K resistor is broken at Q2 on X54-1080-10.
17. Loud audio squeal: Q4 3SB473 on X49-0008-01 shorted.
18. Low receiver sensitivity: Diode D4 1S1587 on RF unit.
19. VFO intermittent: Wire to L1 in VFO is not soldered.
20. No receive: Q4 3SK35Y, Q5 3SK35GR on RF unit.
21. No receive: Q9 3SK35GR on IF unit.
22. Hash noise in receiver: Q3 on RF unit 3SK41.
23. Blows fuse: C31 power supply is shorted, 100uf 500v. Also check associated diode D3, D4.
24. No RX on all bands: WWV switch is broken or a wire is loose or not soldered.
25. Receiver sensitivity: Q5 on RF amp 3SK35Y.
26. Receiver sensitivity: NBO terminal on X48-1060-00 is loose.
27. Low audio: Check for purple wire touch to ground at 12 pin connector in rear panel.

This modification is read 1341 times.

[top of page](#)

19-07-1998

(TS-520) TS-520S -6v Supply Failure

Author: Trio-Kenwood Communication, inc.

Service bulletin no. 43 (9-8-1979)

When troubleshooting a TS-520S, check all power supply voltages, including the -6v DC supply. Symptoms such as dead, blown 2A DC fuse and now dead, low RX, no TX, or similar may occur after switching between 80 and 40M.

Cause of failure may be traced to an intermittent shorting between the 14v dc and -6 dc supplies as the band switch is rotated between 40 and 80 meters. This will weaken or destroy D8, a 6v zener on the FIX CH AVR unit.

To prevent repeat failures, break the White lead and install a 22 K ohm 1/2 watt resistor at the bandswitch S5-6, between the -6v supply line and switch terminal. An of course replace D8 on the FIX CH AVR unit, X43-1100-00.

New Part: 22 k ohm 1/2 W carbon resistor

Please notate your Service Manual.

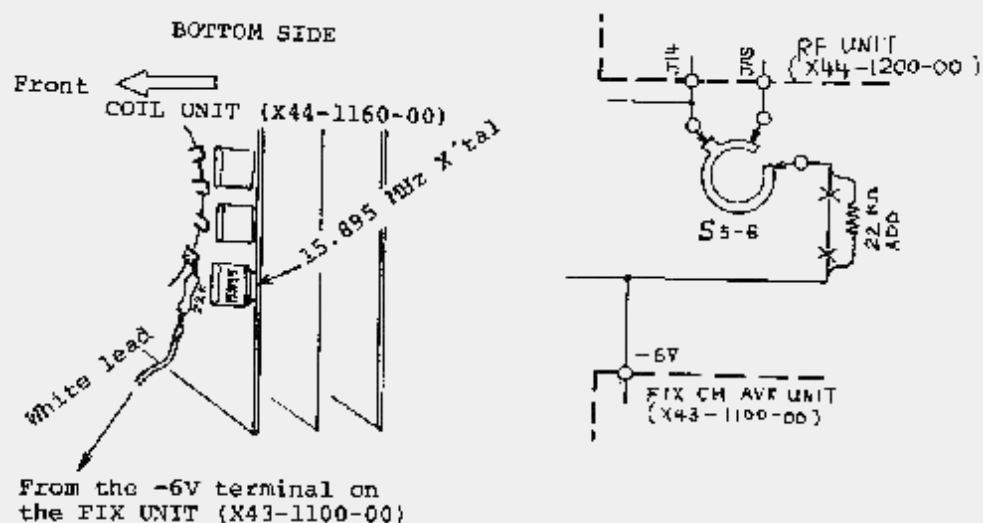

This modification is read 1036 times.

[top of page](#)

19-07-1998

(TS-520) TS-520/520S CW Frequency Shift

Author: Trio-Kenwood Communication, inc.

Service bulletin no. 46 (6-8-1979)

Reports of intermittent frequency shift during CW operation, on the order of a few hundred cycles, may be traced directly to the Carrier Unit.

On the Carrier unit X50-0009-01, install a ground lead of #18 tinned wire or similar, between the cases of T1 transformer and X3, the LSB XTAL.

Recheck frequencies after installing this ground lead.

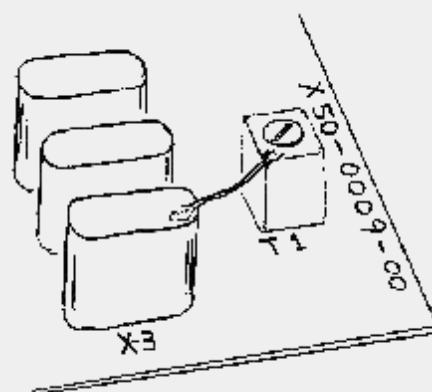

Please notate your service manual.

This modification is read 1039 times.

[top of page](#)

19-07-1998

(TS-520) TS-520 Increased sensitivity, Better audio and Amplitude Modulation

1. Increased sensitivity.

On the RF board, Q5 is the RF RX amp. Notice that G2 is tied to the AGC line. Bend G2 up from the socket, solder a 10k resistor to it and connect the other end of the resistor to the 9v line on the front of the board. This will allow the FET to run wide open, and you will have a better S/N ratio. You will gain about two S units in signal and you may want to adjust your S meter to compensate. I did this mod almost a year ago and have had no problems even with signals that were 40db over!

2. Better audio.

A few capacitors should be changed to accept a wider audio bandwidth.

These will only increase the BASS response and not the treble as it is limited by the IF filter. Change the following on the generator board;

C3 (1 μ F) to 10 μ F
C4 (4.7 μ F) to 47 μ F
C5 (1 μ F) to 4.7 μ F
C8 (.047 μ F) to 4.7 μ F
C9 (1 μ F) to 10 μ F
C11 (4.7 μ F) to 47 μ F
C10 (10 μ F) to 22 μ F

This will make the Tx audio flat. Make sure that the Local Oscillator is adjusted correctly or else you will have the bass attenuated by the IF SSB filter.

I also changed the caps on the AF board.

C14 (.47 μ F) to 4.7 μ F
C13 (.047 μ F) to .47 μ F
C1 (1 μ F) to 4.7 μ F

You will also want to use a good speaker. I have an old speaker box that got gutted.

I put in a 6x9 coaxial car speaker and it sounds great! Since the audio is limited to 4Khz anyway, don't go bonkers with tweeters. You may want to play with a few caps inside the speaker to roll off some of the very highs which will only be transistor noise anyway.

Along with changing the caps for flat audio, I installed two jacks for audio on the back of the 520. These are RCA female jacks that are used to connect to an equalizer.

Unwrap the wire on the generator board marked MA O. This is the output of the Microphone Amplifier. Connect some microphone coax from this terminal to your RCA socket on the back of the rig marked output. Remember to ground both ends of the cable so you won't have hum/RF problems. Now connect the other RCA socket via mic cable to the wire that you unwrapped from the MA O post.

Make up a jumper cable for those times you don't want to use the EQ.

I recommend an old Radio Shack 5 band EQ. I have no RF problems at all and I run 500w PEP with the amplifier sitting next to the Kenwood. Stay away from EQ's that use all IC's. I find regular transistors are better for handling RF.

3. Amplitude Modulation

This radio can talk AM in a pinch. You will be limited to SSB reception though. That's OK if you don't mind playing with the RIT to get rid of the beat tones.

I decided it was degrading the specs when I put in a regular AM detector so I pulled it out. Here is how you make it talk.

Get a DPDT relay (12v) and connect it inline with the fixed channel selector switch, so that when you select crystal 4 the relay energizes.

Now lets take the relay in two sections. The first is connecting the output of the mic amp into a matching transformer via this relay. You want it connected so that the MA O is on the wiper and the relay NC1 is connected to the Balanced Modulator. Connect the other relay terminal NO1 to the low impedance side of the transformer. Connect the other lead of this winding to ground. So when you select fix channel 4, the relay energizes, and disconnects the mic from the balanced modulator and connects it through the transformer to ground.

Ok now the second part of the AM mod.

Take the HIGH impedance winding of the transformer and connect one leg to ground. Take the other leg and connect it to a 47 μ F cap. (neg lead) Connect the positive side of the cap to an 820 ohm resistor.

Connect the resistor to the 9v terminal (on the RF board or most any other board) Connect the junction of the resistor/capacitor to the NO2 terminal of the relay.

Connect the wiper of the relay to S on Q3 on the RF board. I found R17 to have its exposed wire connected to S on Q3. Simply scratch the paint away on R17 and solder to the resistor.

Since this design modulates after the IF, you will have full fidelity and bandwidth of your audio. If you use an EQ, don't be excessive with the highs or you will have enemys from the splash you create. Also, there is no limiter here. If you have access to one, install it in the EQ loop.

Have fun on 80M!!

73's

For more info or if you have questions;

Greg Weremey - Electronic Service Pros. www.angelfire.com/ma/electroservepro

Be sure to check out the D-104 modification page and listen to the audio demonstration!

05-04-1999

(TS-520) Kenwood TS-520S for QRP

The TS-520S can be operated QRP down to a few milliwatts with simple modification. Apply negative voltage on the ALC pin of the ancillary socket.

Modification consists of a 220K Ohm pot and a 9V battery.

Positive terminal of battery to ground (Pin 4)

Negative terminal of battery in series with 220K pot to ALC pin on socket. (Pin 6)

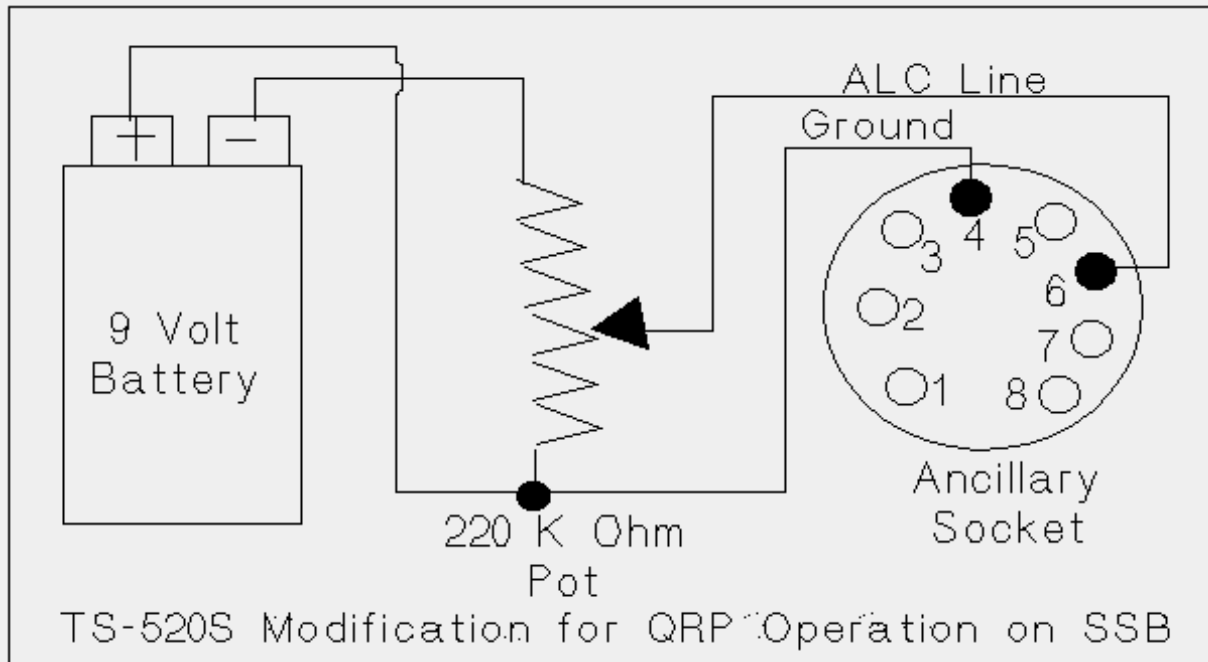

Maximum of 34 microamps drawn so battery should last a long time.

Bob Wilder, W4RHW

This modification is read 1175 times.

[top of page](#)

05-06-1999

(TS-520) TS-520S MARS Mod for 4.0-4.6MHz

Author: Jim - WB4WBL

After trying for several months, I have finally come across a modification for the Kenwood TS-520S that will allow this rig to be operated in the 4.0 to 4.6 MHz range in MARS operation. The modification came originally from Jim, WB4WBL (AF MARS AFA2FN) in Tampa, Florida.

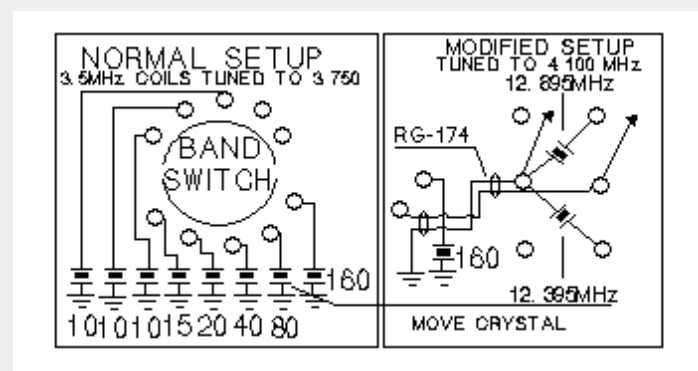

The modification consists of moving the 12.395 MHz crystal from the Band Switch to a small DPDT toggle switch mounted on the bottom of the case. An additional 12.895 MHz crystal is added to the switch for the new range needed.

This new crystal can be obtained from International Crystal Manufacturing Company. The crystal is 20pf, wire lead type.

A short piece of RG-174 coax is used to connect the new switch with its attached crystals back to the Band Switch position from which the 12.395 MHz crystal was moved from.

Once the crystals are in place, the 3.5 MHz coils are retuned to a new center frequency of 4.100 MHz. The normal tuning of all the 3.5 MHz band coils are tuned to 3.750.

The new switch is mounted between the front of the radio and the heterodyne oscillator board.

Jim says that he still has a TS-520 with the mod in it and it still works great after almost 20 years. He has modified several 520's over the years they all worked great.

73 Bob Wilder, W4RHW
USAF MARS AFA2HD

This modification is read 1177 times.

[top of page](#)

12-02-2000

(TS-520) TS-520 Novice Operation (75 watts)

Author: Trio-Kenwood Communication, inc.

Service bulletin no. 2 (10-01-1975)

HV UNIT (X43-1100-00)

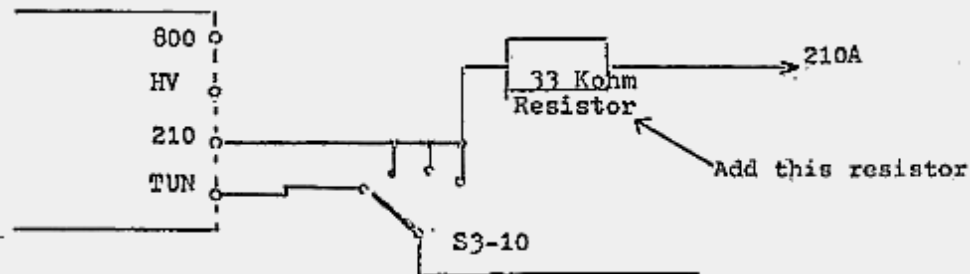

1. Cut wire (See figure 1) red color.
2. Insert 33kohm resistor in series between red wire and pin 210.
3. readjust bias current to 60mA.

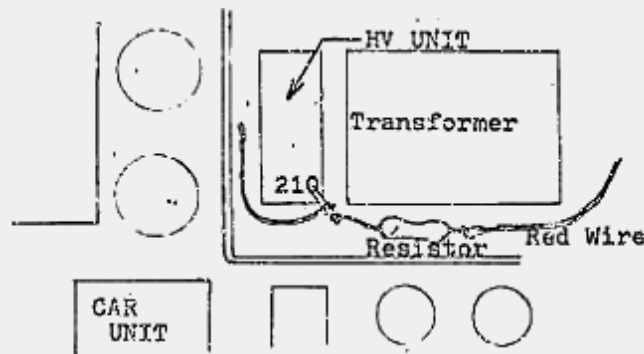
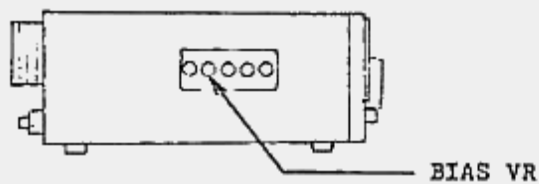

Figure 1 (Bottom side)



This modification is read 1090 times.

[top of page](#)

12-02-2000

(TS-520) AM Broadcarst interferenc in TS-520

Author: Trio-Kenwood Communication, inc.

Service bulletin no. 4 (June 3 1975)

We have found a few instances of customers who live near an AM broadcast station hearing that station on the 3.5 MHz band of their TS-520. Shown below is a filter that may be installed if this occurs.

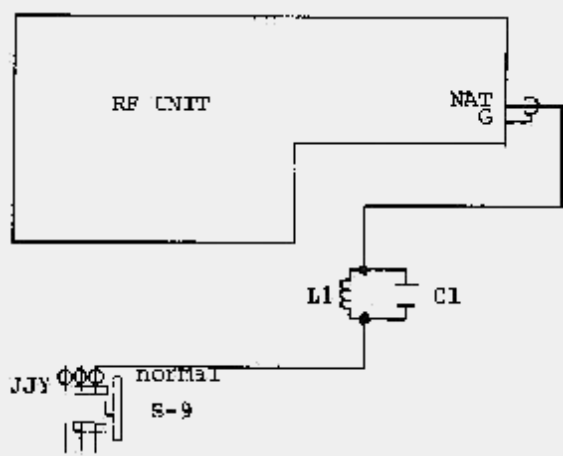

Freq.	L1	C1
1300 KHz	22uH	680pF
1000 KHz	200uH	220pF
700 KHz	100uH	470pF

A Suggested located for the filter is on a small terminal strip that is then mounted on a mounting screw of the RF unit. This screw is located at the front corner next to the VFO. The cable between S-9 (WWV switch) and terminal NAT of the RF unit is removed from terminal NAT and connected to one side of the filter. A short piece of RG-174/U is then connected from the other side of the filter to the terminal NAT. This should prevent the AM broadcast interference.

This modification is read 1035 times.

[top of page](#)

20-02-2000

(TS-520) TS-520/520S BS-5 Sweep interference

Author: Trio-Kenwood Communication, inc.

Service Bulletin no. 52 (10-8-1979)

BS-5 users may report ignition-like interference on 80 & 40 M from their SM-220 with BS-5. Noise will be heard between 3850-3870 KHz, and 7245-7260 KHz any time the scope is on.

The sweep signal mixes with the IF (carrier) frequency. This derived signal, or its second harmonic will usually be less than an S1 signal, unless the coax ground to the scope is opened, in which case S9 may be indicated.

On the SM-220 PCB X65-1240-00, change the BS-5 +11V DC supply point:

1. Cut the foil path between connector P110 pin 6 and Connector P103 pin 2.
2. Install a 1S1555 diode between Connector P110 pin 6 and Connector P103 pin 1.

New Part: 1S1555 V11-0076-05

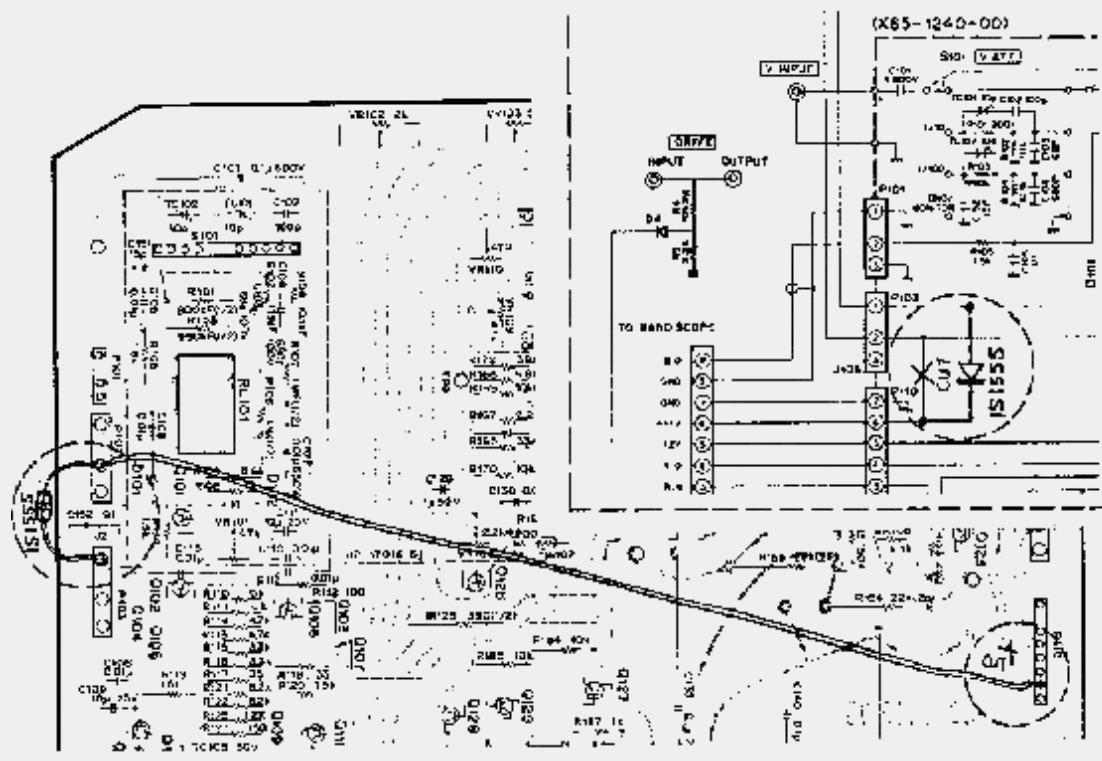

Please notate your Service Manual: SM220, TS-520 & TS-520S

This modification is read 1006 times.

[top of page](#)

18-03-2000

(TS-520) Adding IF output to the TS-520 and TS-520S transceivers for use with th SM-220

Author: Trio-Kenwood Communication, inc.

Service Bulletin no. 63 (16-8-1978)

The TS-520 and TS-520S transceivers do not provide an IF output signal. It is necessary to have this if you want to look at a specific received signal on the SM-220 station monitor. The best place to pick up this signal is at the tuned output of Q4 on the IF unit (X48-1060-00).

A 22 pF capacitor should be used for coupling and a 10 Kohm resistor for impedance matching. This is shown in the schematic below. The center conductor of a 39 cm (14") length of 50 ohm (RG-174/U or similar) cable is connected to the pick-up at one end and to pin 7 of the REMOTE socket and the ground path of the IF Unit. A 75 cm (30") 50 ohm cable should be made up with one end connected to pins 7 and 1 of the 8 pin plug supplied with the transceiver and BNC connector on the other end. The BNC connector will be plugged into the vertical input jack on the front of the SM-220.

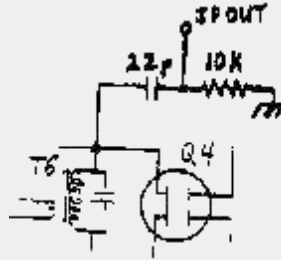

This modification is read 1064 times.

[top of page](#)

02-04-2000

(TS-520) DS-2 Replaces DS-1A DC-DC Converter

Author: Trio-Kenwood Communication, inc.

Service Bulletin no. 842 (26-1-1981)

The DS-1A DC-DC converter for the TS-820 series and TS-520/S has been replaced by a new model, the DS-2. Wiring color code is the same. Physical size is smaller. Two additional mounting holes must be drilled in the transceiver rear panel.

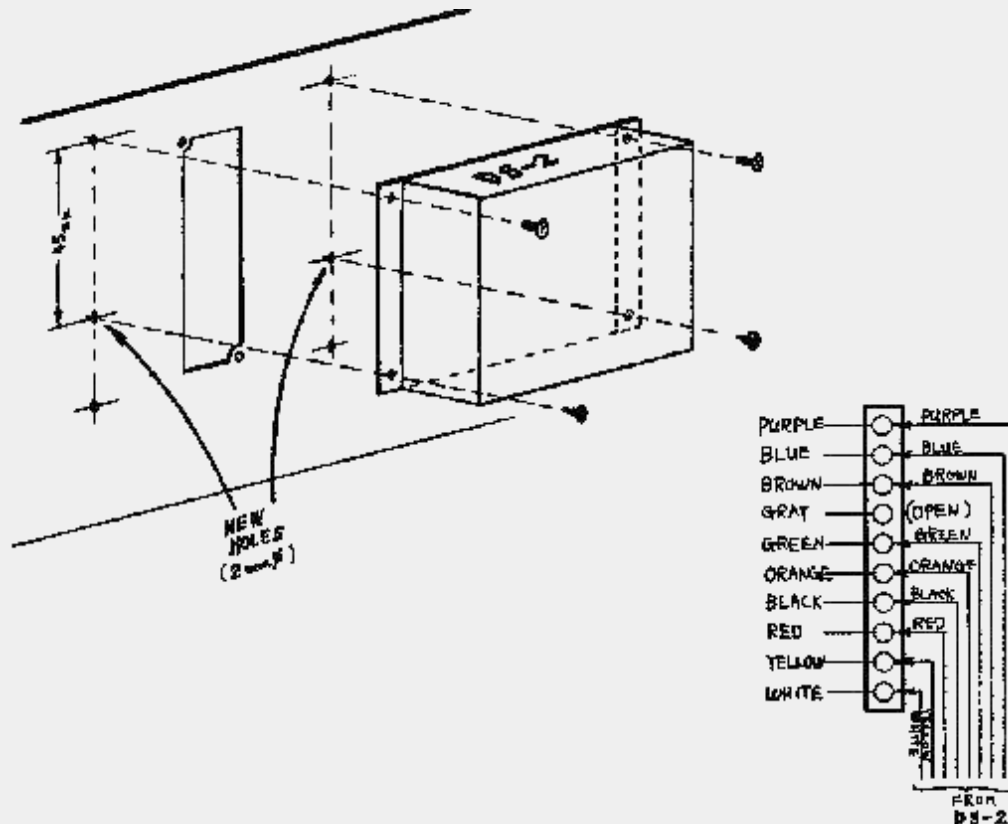

This modification is read 978 times.

[top of page](#)

30-03-2001

(TS-520) Increase the sensitivity for 10 and 15 meter band

Author: Tim - Timloretta@aol.com.MODIFICATION.NET

I have a mod for the TS-520, change Q4 & Q5 from an 3SK35 to a 3N211 or NTE454 or an 3SK63GR, this will increase the sensitivity on the 10 & 15 meter band.

I tried it on my TS-520 and got about 2 s-units gain on 10 & 15 meter band. This makes a big difference on the weak signals.

Note this mod also will work on the yeasu FT-101 series EE EX etc. The FET's on the 101 are located behind the VFO under the metal lid. And the other on the board on the right side of the VFO...

73's Tim

This modification is read 1297 times.

[top of page](#)

19-07-1998

(TS-530) QRO Modification to TS-830S, TS-530S

SUBSCRIBER'S COMMENTS ON QRO MODIFICATION TO TS-830S, TS-530S AND TS-530SP

I would like to pass on the problem I have encountered in connection with the QRO modification to the Kenwood radios TS830S, TS-530S and the TS-530SP.

The problem occurs after many hours of long winded QSO's. It seems that with the increase in the screen voltage from 210 to 300 volts, R37 on the RF unit (#X44-1360-00) heats up tremendously and will change its value so greatly that even the receive either suffers or goes out totally. R37 originally is Metalfilm resistor at 3.3K ohms and is 1/2 watt.

I have changed mine to a Metalfilm as original same value but have used a one watt resistor. The brand I was able to get was RCA and I suppose there are better on the market. This is a 2% tolerance. Three units that I know of have had this problem that I took care of in this area alone. Two units were TS-830S and one a TS-530SP. Just thought I would pass that information along for what it is worth. (Thanks, Frank J. Lukas, Jr., 5301 Main Ave., North Ridgeville, OH 44039)

This modification is read 1194 times.

[top of page](#)

19-07-1998

(TS-530) TS-530S Low Voltage Supply Optional Improvements

Author: Trio-Kenwood Communication, inc.

Service Bulletin no. 848 (30-7-1981)

Power supply drift and stability may be improved by these optional components changes and additions.

On the AF AVR unit X49-1140-00 (Vicinity of Q19-Q20) changes:

R68 from 1 Kohm to 1.5 Kohm (RD14CB2E152J)

R72 from 470 ohm to 390 ohm (RD14CB2E391J)

D14 from WZ-061 to XZ-053 (V11-4101-60)

* This will improve temperature drift from a maximum of about 100mV to a maximum of 10 mV, and may be applied to any unit before serial # 201xxxx.

Note: These changes are at the owners option and may not be performed in-warranty.

This modification is read 957 times.

[top of page](#)

19-07-1998

(TS-530) TS-530S IF Unit Q2, Q7 Protection

Author: Trio-Kenwood Communication, inc.

Service Bulletin no. 878 (25-8-1983)

High voltage transients at the receiver antenna can be felt in the ALC circuitry and cause a failure of IF unit transistors Q2 and Q7. Symptoms encountered may be a loss of RX sensitivity, and or loss of S-Meter deflection.

Add the surge suppressor to the AF unit (X49-1150-XX) between terminal FG and ground, to prevent a recurrence of this symptom.

Parts required:

Surge Suppressor #ERZD03DK331

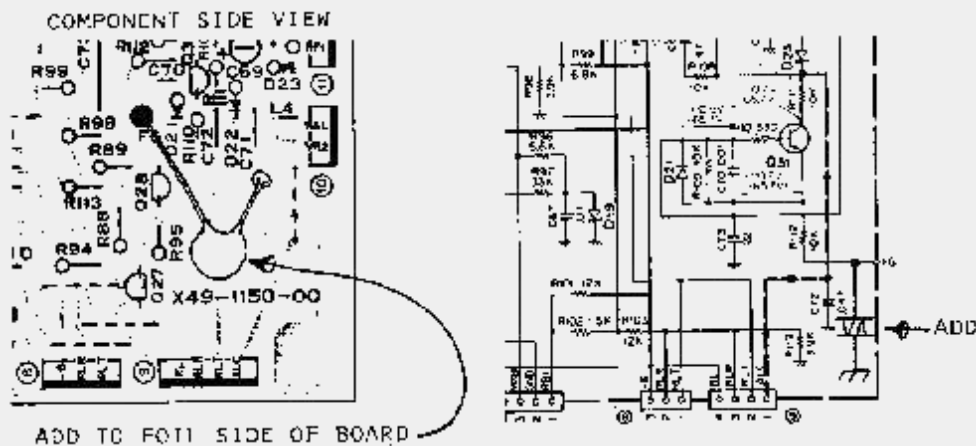

Time required for this modification is 1/2 hour or less.

This modification is read 943 times.

[top of page](#)

19-07-1998

(TS-530) TS-530 WARC bands

As supplied, the TS-530 will receive but not transmit on the three new warc bands. If transmit capability is desired, a minor wiring change is required.. There are just two minor changes that could be made and they are as fellows

1. For all 3 bands break the line between the rf unit X44-1360-01 connector #6, pin #1 (top terminal) and AF unit X49-1150-00, connector #7, pin #4 (top terminal).
2. Or, for individual bands on the rf unit X44-1360-01:

Band	Remove/cut
10 MHZ	D4
18 MHZ	D5
24.5 MHZ	D6

I did the first modification and found it to be the best way to go, good luck and happy hamming !

de KC2AR Bob in STARRUCCA,PA.

This modification is read 1147 times.

[top of page](#)

19-07-1998

(TS-570) Problem width the memories

From: PA3HGA@PI8WFL.#NH1.NLD.EU

I bought last year a Kenwood TS-570D HF transceiver. After a few months of good working i got a problem : Everytime if i switch off the power i lost all the memories, including the value for the IF filter bandwidth (menu item 46) which is normally held even if you reset the transceiver! I thought immediately on a battery problem. It was, but there was more. I got garanty to this transceiver so i brought it away for a repair. They tell me it was a known problem by Kenwood that "a reset IC" was causing this trouble. They replaced a battery and an IC. Remember this if you got problems with your transceiver !

73, Reg de PA3HGA
BLOKKER / PA3HGA @ PI8WFL.#NH1.NLD.EU
E-MAIL : PA3HGA @ AMSAT.ORG

This modification is read 1873 times.

[top of page](#)

19-07-1998

(TS-570) TS570D : durchg. Sendebere

Hallo , TS570 - Besitzer !

Fuer meinen OV - Kollegen Peter , DH8PW , habe ich heute dessen TS570D so modifiziert , dass man damit auch ausserhalb der Afu - Baender senden kann . Da ich diese Mod. hier in pr nirgends gefunden habe , und weil sie funktioniert , spiele ich sie hier 'mal ein :

1. Alle Kabel abmontieren (Ant , Stromversorgung , ALC , Paddle usw.)
2. Deckel und Boden abschrauben
3. seitlich Schrauben des Bedienteils abschrauben .
4. Bedienteil wegklappen , evtl. ganz abtrennen .
5. Auf der am Geraet verbliebenen Platine (X53-3690-10) den IC CXD1095Q suchen.
6. Den 1KOhm - SMD - Widerstand (Aufdruck 102) finden und ausloeten . Er befindet sich links unterhalb des o.g. ICs , rechts neben einer Schraube .
7. Das Geraet wieder zusammenbauen und verkabeln .
8. Beim Einschalten auf A=B druecken und damit einen RESET ausloesen . (Evtl. die alten Voreinstellungen notieren ...)

Fuer die Richtigkeit uebernehme ich keine Garantie , diese erlischt vermutl. beim Oeffnen des Geraetes . Ich habe auch keine weiteren Mod. - Tips .

This modification is read 1782 times.

[top of page](#)

23-01-1999

(TS-570) Kenwood TS-570D MARS/CAP Modification

Author: Kenwood Communication, inc.

This modification is provided "as is", and is subject to change without notice. Kenwood Service Corporation makes no warranty of any kind regards to this modification procedure, including, but not limited to, the implied warranties of merchantability and fitness for a particular purpose. Kenwood Service Corporation shall not be liable for any error or for incidental or consequential damage in roujunction with the furnishing, performance, or use of the modification procedure.

It is illegal to operate outside the limits of your class license or permits.

1. Disconnect the power cord and antenna coax from the transceiver.
2. Remove the top and bottom covers.
3. Remove the top screw from each side of the front panel assembly.
4. Loosen the bottom screw from each side of the front panel assembly.
5. Carefully rotate the front panel forward to gain access to the Control board (X53-3690-10).
This board is mounted vertically against the body of the transceiver. It is not the board that is mounted in the front panel assembly.
6. Locate and remove the chip resistor R41 from the Control board.

7. Assemble the transceiver then perform the CPU reset procedure by holding the A=B button depressed as power is turned on.

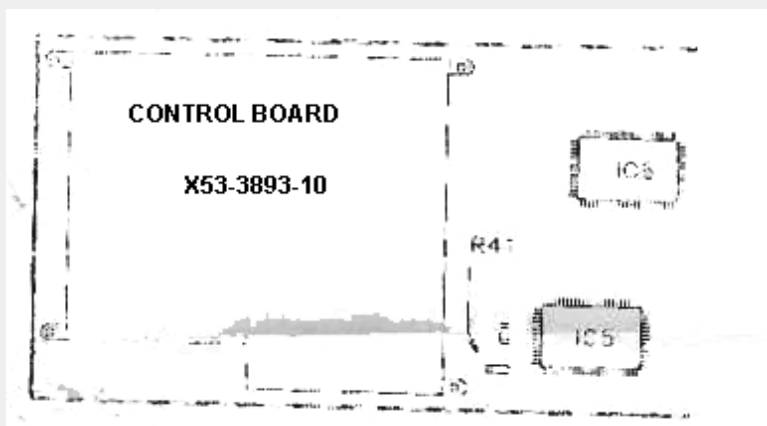

This modification requires soldering equipment rated for CMOS type circuits. It also requires familiarity with surface mount soldering techniques. If you do not have the proper equipment or knowledge do not attempt this modification yourself. Seek qualified assistance.

This modification is read 2421 times.

[top of page](#)

28-03-1999

(TS-570) TS-570 Batteries

This mod is a copy of the mods from [Kenwood TS570 Batteries](#). Thanks to Al Williams.

It seems incredible, but there is a lithium battery in the Kenwood TS570 that apparently lasts about 6 months. Replacing it is a major trip into the innards of your radio.

Clif of [AVVID](#) (a Kenwood Service center) was kind enough to tell me what to do, and I thought I would write up his instructions and my experience in case someone else needs it.

According to Clif, the microprocessor must reset correctly or the battery will drain quickly. Therefore you must follow these instructions, as odd as they seem.

Before you begin, you need the radio on a nonconductive surface, a phillips screwdriver and a CR2032 battery (Radio Shack has them). You also need the radio's power supply hooked up.

1. Have the radio hooked up to 12V. Turn the radio off but leave the supply on.
2. Remove the four screws from the top of the case.
3. Then remove the 4 screws on the side and lift the top free.
4. Turn the radio over and remove the 4 screws from the bottom that holds the entire case on. Don't bother with the service panel.
5. Turn the radio right side up and notice there are 4 screws (2 on each side) that hold the front panel on. Two of these are in slots, and two are in holes. Remove all 4 screws. BE CAREFUL. The panel is attached with several cables and yanking them loose is probably not a good idea.
6. Carefully separate the panel from the radio chassis. Note the battery in the little holder. The + side of the battery is facing out.
7. The battery holder is spring-loaded; you don't need to open it. Just gently push the battery and slide it upwards, freeing it of the holder and replace it with the new battery (remember + faces you).
8. Reseat the panel, lining up the screw holes and replace the screws.
9. If you want, at this point, turn the radio on and off again.
10. Replace the covers. Remember, don't put the side screws in until the top and bottom are in place.

That's it! According to Clif the problem won't reoccur. We'll see! Just be careful when you attempt this. Lots of things can go wrong. The case is very tight fitting, so don't drop the pieces and bend them out of shape or you will be sorry. Good luck!

UPDATE

As of March 29th, my battery failed again (yep, about 6 months). I have a month left on my warantee, so I'm planning on trying to get something resolved. I'll post here about what I find out.

Kenwood did in fact take the Radio back and apparently installed a diode at no charge. With any luck, this will fix the problem.

This modification is read 1944 times.

[top of page](#)

26-06-1999

(TS-570) Kenwood TS-570DG MARS/CAP Modification

Author: Bill NOQVW

This is for the DG model only!

1. Disconnect the power cord and antenna coax from the transceiver.
2. Remove the top and bottom covers.
3. Remove the top screw from each side of the front panel assembly.
4. Loosen the bottom screw from each side of the front panel assembly.
5. Carefully rotate the front panel forward to gain access to the Control board (X53-3690-10). This board is mounted vertically against the body of the transceiver. It is not the board that is mounted in the front panel assembly.
6. Remove the square cover with 4 screws on it. LOCATE IC 5 go to the lowest point by ic 5 there are 2 resistors between the is 5 chip and the screw hole REMOVE the HORIZONTAL ONE
7. Assemble the transceiver then perform the CPU reset procedure by holding the A=B button depressed as power is turned on.

You will now have all the other frequencys you couldnt transmit on now...

Thanks to Mike Fauchaux mikef@sat.net.MODIFICATION.NET for the picture below.

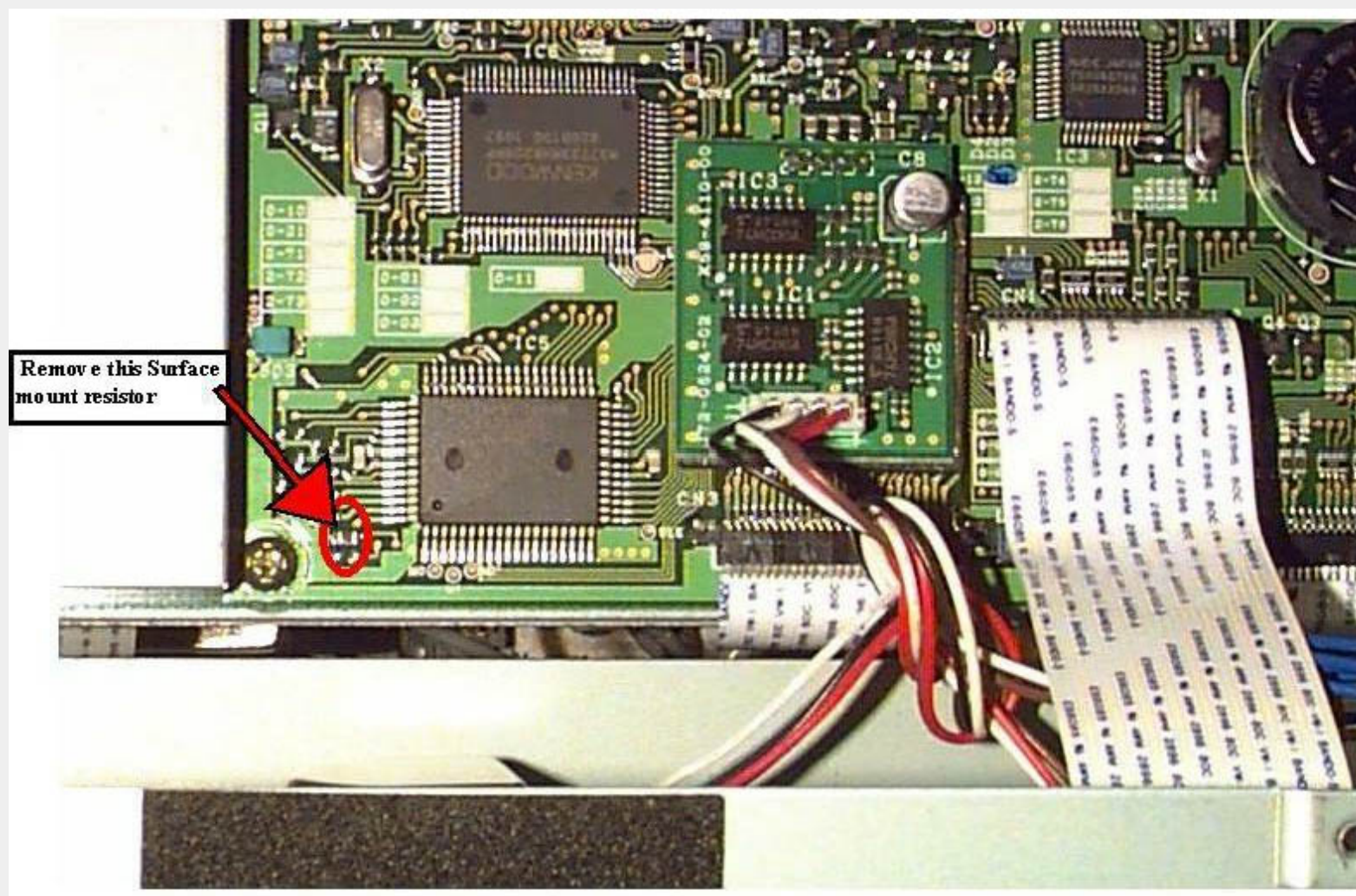

This modification is read 2270 times.

[top of page](#)

23-04-2000

(TS-570) TS-570 Back-up battery current drain

When the transceiver is turned off, there is a momentary increase in back-up battery current drain. In addition, if a personal computer is connected to the transceiver, excessive back-up battery current drain can occur when the transceiver is turned off. The following circuit changes will eliminate the increased current drain.

Caution: *This modification requires soldering equipment rated for CMOS type circuits. It also requires familiarity with surface mount soldering techniques. If you do not have the proper equipment or knowledge do not attempt this modification yourself. Seek qualified assistance.*

Parts required:

Qty	Description	New Part No.
2	10 Kohm resistor	RK73FB2A103J
1	Diode	1SS355 *
1	470 ohm resistor	RK73FB2A471J **

* You can substitute an MA110 diode in place of the 1SS355 diode.

** The 470 ohm resistor is only required for S/N 903xxxxx and higher.

Procedure:

1. Disconnect the power cable and remove the covers of the transceiver.
Access the foil side of control board X53-3690-11.
2. Remove the solder resist from three foil locations.
3. Cut one foil trace. Do not cut too deep.
4. Add the two 10 Kohm resistors and one diode.
5. On the component side of the Control board, replace R36 with a 470 ohm resistor if a 10 Kohm resistor is installed (This must be done from S/N 903xxxxx and higher).
6. Remove the lithium battery and measure it's voltage. If it measure 2.8 V or less, you need to replace the battery with a new one (part number W09-0873-05).

Battery installation procedure:

Perform the following steps when installing the original or replacement lithium battery.

1. Once the battery is removed from it's socket, wait 20 seconds or more before going to the next step.
2. Connect a power supply to the transceiver. The transceiver should turn on by itself.
3. Install the original or replacement battery.
4. Turn off the transceiver from the front panel power switch.
5. Reset the transceiver by holding A=B key depressed while turning on the transceiver from the front panel power switch.

Units with a number 3 stamp on the outside box were already modified at the factory.

CONTROL BOARD FOIL SIDE VIEW
X53-3690-10

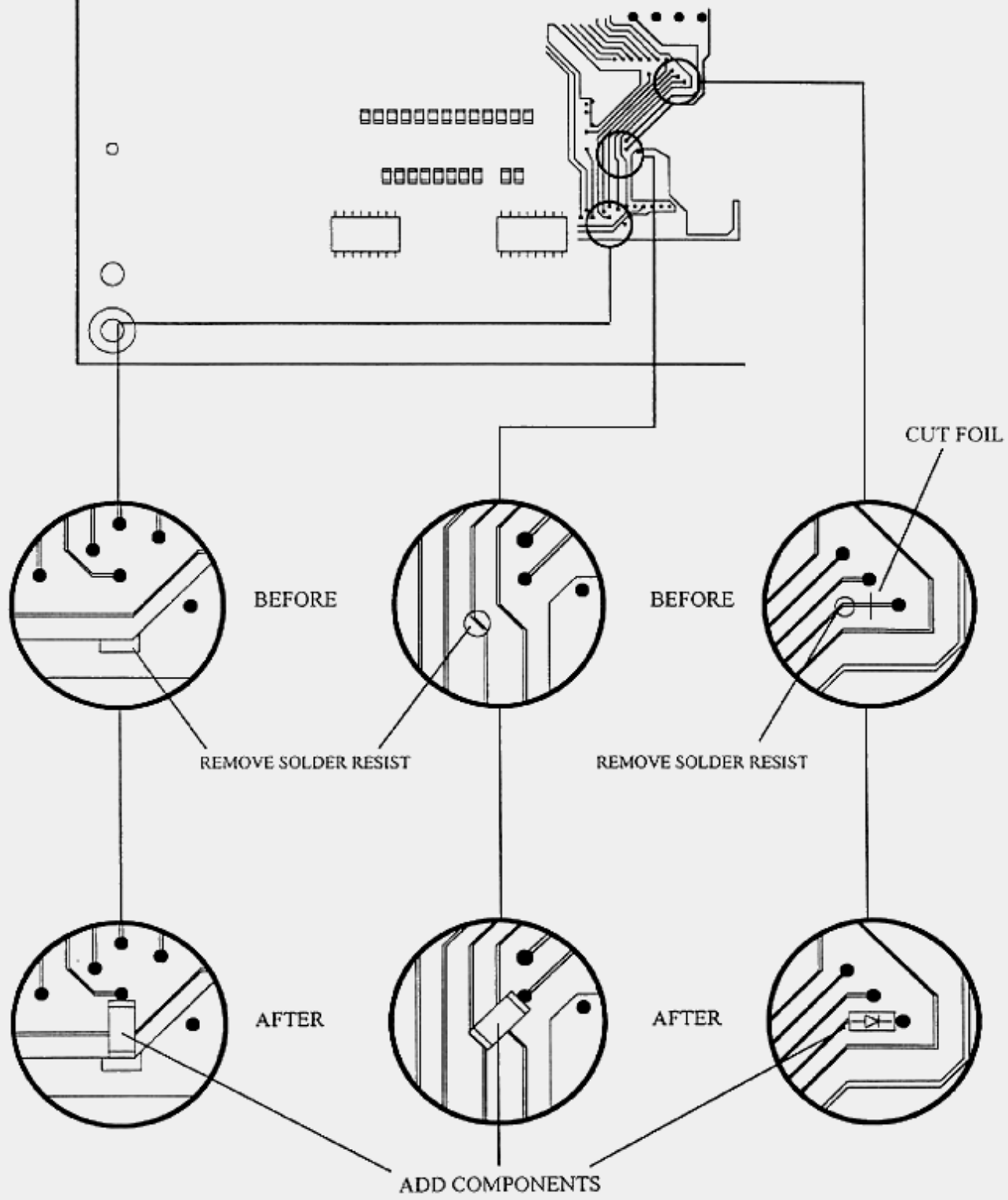

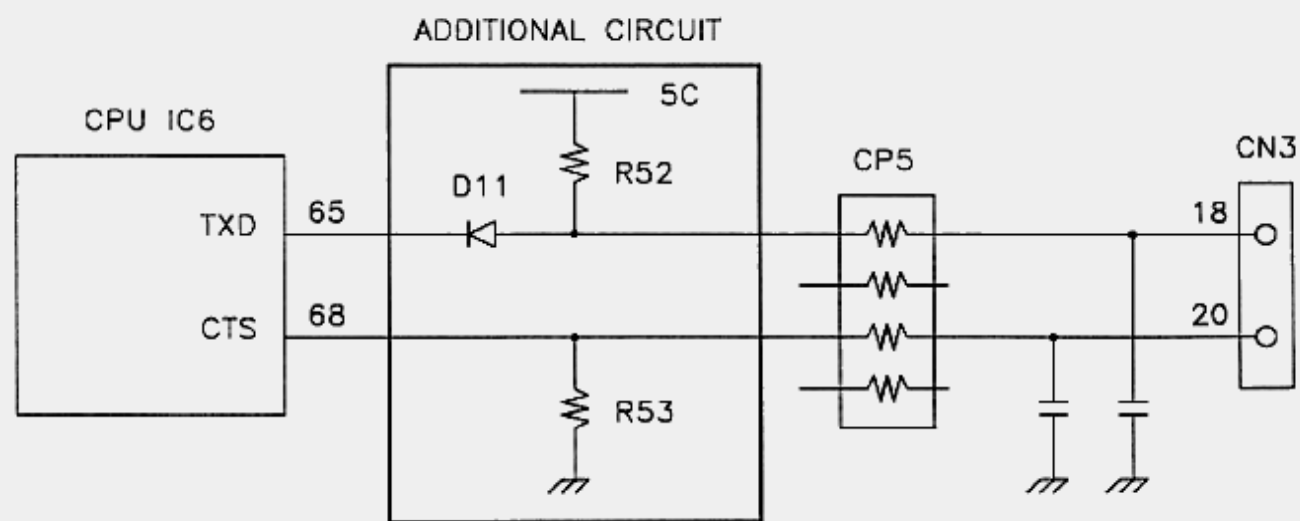
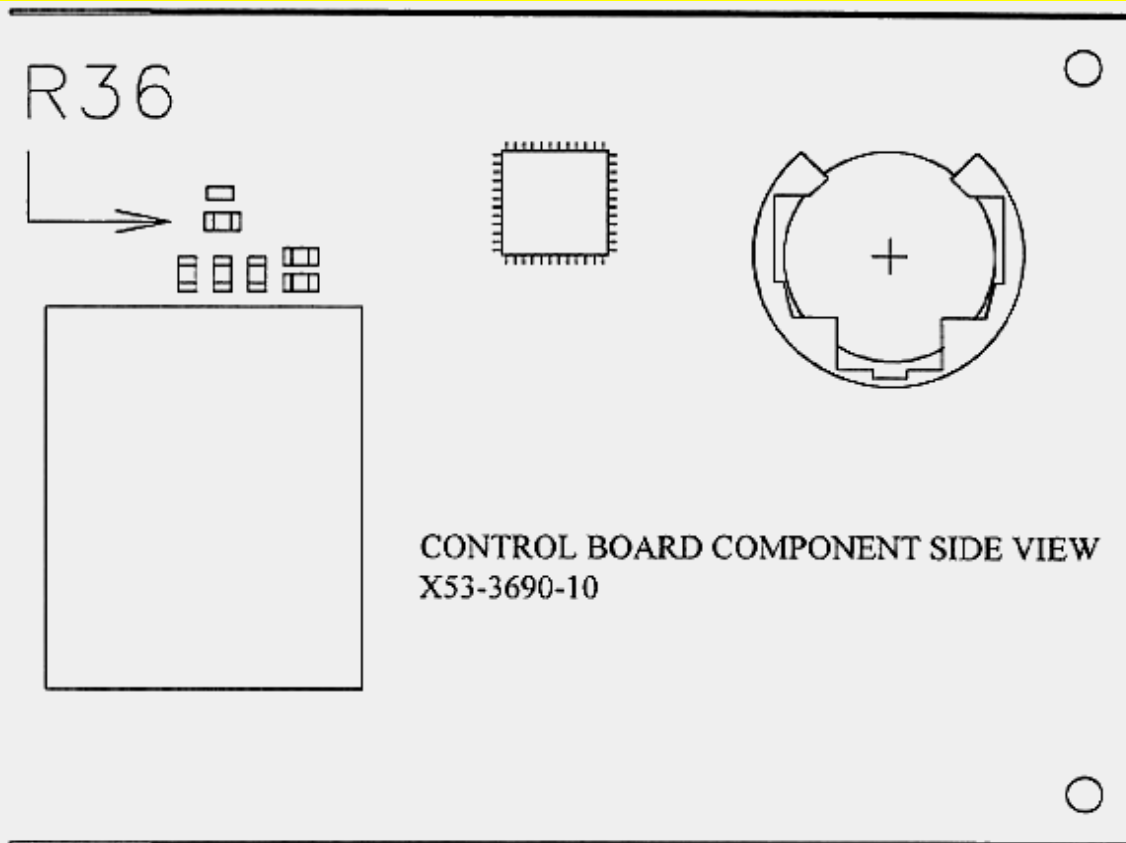

SIMPLIFIED SCHEMATIC OF CIRCUIT CHANGES

Time required to make this changes is 1 hour.

This modification is read 1867 times.

[top of page](#)

03-11-2000 (TS-570) How to find out the real version of TS570DG

1) Push MENU key on front panel.

Find optional CW filter setting menu.

If there are more menu Nr. like NR1 LEVEL, over CW filter setting Nr. this set is G type.

If next to CW filter setting is 1st menu item, it is not G type.

2) In SSB mode, push BC key to turn on BC.

Then push and hold pushing BC key and if you hear beep, this set is G type.

If there is no beep it is not G type.

This modification is read 2372 times.

[top of page](#)

In order to modify TS-60s(E) to receive from 40.000 MHz, please follow the modification below. But please note that it is not recommended for the novice operator/technician and require DVM or VTVM.

1. Open the case
2. Locate Digital unit, X46-3182-71
3. Remove or cut either side of the diode, D3 and D4

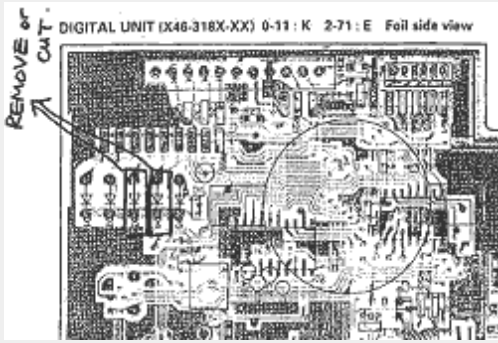

4. Locate PLL unit, X50-3200-00
5. Connect the DC cable to the power supply
6. Reset microprocessor by depressing **A=B** key while turning it on
7. Now tune the dial to 40.000 MHz
8. Connect VTVM or Digital DC volt-meter (DVM) to **TP2** on PLL unit, X50-3200-00.

ADJUSTMENT

Adjustment Points

TX-RX UNIT (X57-4570-00) (A/4)

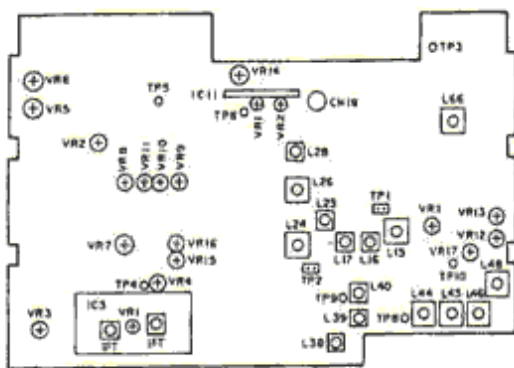

- | | |
|--------------------------------|-------------------------------|
| TX-RX UNIT (X57-4570-00) (A/4) | VR14 : Hi power |
| VR1 : MIX BAL | VR15 : Low power |
| VR2 : FM meter | VR16 : Mid power |
| VR3 : SSB equalch | VR17 : Spurious |
| VR4 : RFG | L15-17 : MCF |
| VR5 : Side tone | L24-26, 28 : IF AMP |
| VR6 : Beep tone | L38-40, 44-46, 48 : TX AMP |
| VR7 : MIC sensitivity | E66 : RX AMP |
| VR8, 9 : Suppression | VR1 in IC3 : SSB S-meter (S1) |
| VR10 : MIX BIAS (AM) | IFT in IC3 : IF AMP |
| VR11 : MIX BIAS (CW) | VR1 in IC11 : SWR protection |
| VR12 : MIX BIAS (MAX) | VR2 in IC11 : ALC voltage |
| VR13 : Spurious | |

FINAL UNIT (X45-3490-00)

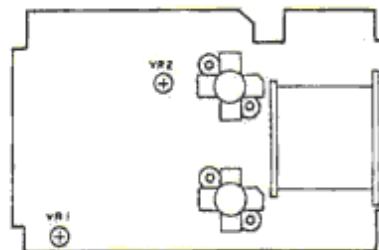

FINAL UNIT (X45-3490-00)
VR1, 2 : Final idling current

PLL UNIT (X50-3200-00)

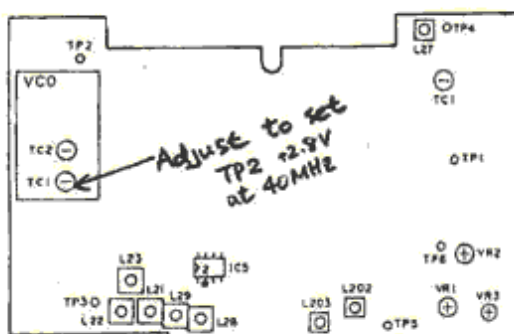

- | | |
|---------------------------|-----------------------|
| PLL UNIT (X50-3200-00) | VCO (X58-4120-00) |
| VR1 : FM MIC sensitivity | TC1, 2 : Lock voltage |
| VR2 : FM MAX DEV | |
| VR3 : Sub tone | |
| L21-23 : 75.045-75.545MHz | |
| L27 : 10.695MHz | |
| L28, 29 : 80MHz | |
| L202, 203 : NB | |

TX-RX UNIT (X57-4570-00) (C/4)

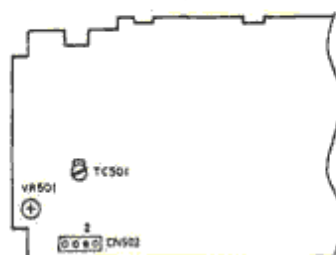

TX-RX UNIT (X57-4570-00) (C/4)
VR501 : Power frequency response
TC501 : NULL

9. Turn TC1 to set the voltage of **TP2** at 2.8 VDC (Never touch TC2!!! because it has been adjusted at factory)

Now TS-60S can receive from 40.000 MHz to 60.000 MHz and transmit 50.000 MHz to 54.000 MHz.

This modification is read 576 times.

[top of page](#)

08-04-2000

(TS-660) TS-660 Microprocessor Latchup

Author: Trio-Kenwood Communication, inc.

Service Bulletin no. 856 (25-1-1982)

Microprocessor latchup may occur if the power switch is cycled several times in quick succession, if the supply is turned off while the power switch remains on, or if the power supply is turned on with the transceiver already on. Symptom will be no display, erroneous display, or locked display. Change two components on the control unit to prevent further trouble.

On the control unit X53-1220-00:

1. Replace R23 680 ohm with a 470 ohm resistor (RD14CB2E471J).
2. Remove and delete C4 47uF
3. Add a 22uF 16V electrolytic (CE04W1C220M) on the foil side on the board between D24, R23 (positive) and ground (negative).

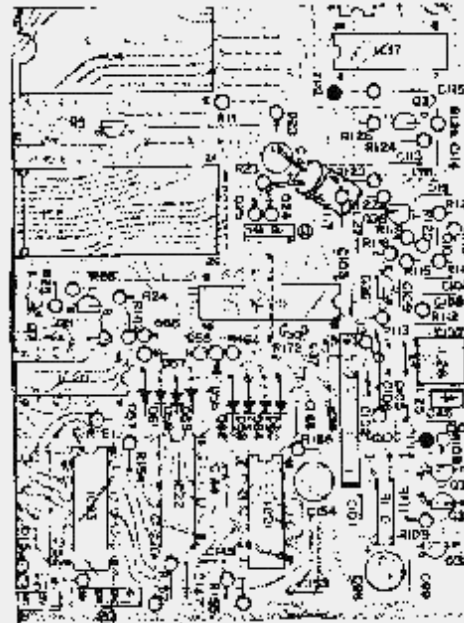
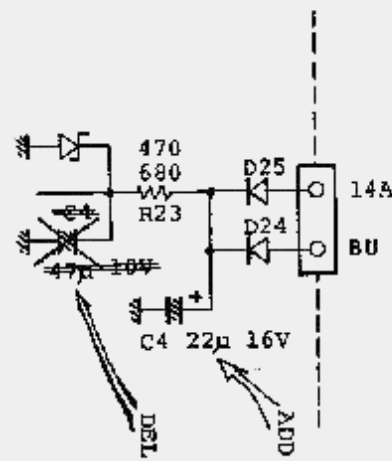

Notes:

1. This change applies to units before serial number 209xxxx.
2. Installation time for this procedure is ½ hour or less.

This modification is read 504 times.

[top of page](#)

26-06-2001

(TS-660) TS-660 Coverage to cover 20-33MHz and 46-55MHz

Author: Adam MAURER, VK4CP - vk4cp@bigpond.com. MODIFICATION.NET

Modification summary:

The "n" data to the 1MHz PLL needs to be changed so as to introduce a 1, 2, 3 or 4 MHz offset.

Access to the PLL Unit is required.

There are many ways of achieving this, from a simple toggle switch to introduce a -4MHz offset to more elaborate schemes involving EPROMs and the like.

I must thank Graham, VK6RO, who originally published the idea (1982) of shifting the coverage down 4MHz to copy TV signals in the 46-50MHz range. It was Graham's idea that prompted me to create my own TS-660 mods in 1986, as detailed here. Although I reluctantly sold my 660 in 1996 I present the mods here to those who may be interested.

Bill of Materials:

1 x CMOS 4008 4-Bit adder

1 x 4 position miniature rotary switch

1 x 1N914 diode or equiv

2 x 10k ¼W resistors

hookup wire

veroboard

Band Truth Table (original coverage):

MHz	D	C	B	A	n	Notes
						1) D=8 C=4 B=2 A=1
21	0	1	0	1	10	2) Logic is inverted
24	0	0	1	0	13	
26	0	1	0	0	11	
27	0	1	0	1	10	
28	0	1	1	0	9	
29	0	1	1	1	8	
50	0	1	0	0	11	
51	0	0	1	1	12	
52	0	0	1	0	13	
53	0	0	0	1	14	

As you can see the "D" input to Q15 is always "0" and permanently tied low.

Band Truth Table (expanded coverage):

MHz	D	C	B	A	n	Offset from nearest band
20	0	1	1	0	9	-1MHz & -1n from 21MHz
21	0	1	0	1	10	
22	0	1	0	0	11	+1MHz & +1n from 21MHz
23	0	0	1	1	12	-1MHz & -1n from 24MHz
24	0	0	1	0	13	
25	0	0	0	1	14	+1MHz & +1n from 24MHz
26	0	1	0	0	11	
27	0	1	0	1	10	
28	0	1	1	0	9	
29	0	1	1	1	8	
30	1	0	0	0	7	+4MHz & -4n from 26MHz
31	1	0	0	1	6	+4MHz & -4n from 27MHz
32	1	0	1	0	5	+4MHz & -4n from 28MHz
33	1	0	1	1	4	+4MHz & -4n from 29MHz

```

46 1 0 0 0 7 -4MHz & -4n from 50MHz
47 0 1 1 1 8 -4MHz & -4n from 51MHz
48 0 1 1 0 9 -4MHz & -4n from 52MHz
49 0 1 0 1 10 -4MHz & -4n from 53MHz
50 0 1 0 0 11
51 0 0 1 1 12
52 0 0 1 0 13
53 0 0 0 1 14
54 0 0 0 0 15 +1MHz & +1n from 53MHz

```

You will need to access the "D" line as we now need to switch that as well.

(This may involve cutting a track or removing a link to ground - I can't remember which!)

Switching the offset in:

In order to switch in the offset I removed the 6.5mm Key socket mounted on the rear and replaced it with a miniature 4-position rotary switch. The switch was wired for;

1. Normal
2. -1MHz offset
3. +1MHz offset
4. 4MHz offset

You will note from the truth table that for both +4MHz and -4MHz we need to subtract 4 from the n-count anyway.

The adding & subtracting is achieved by using a CMOS 4008 4-bit Full adder.

Refer to the schematic below;

The original band data is fed into the "A" inputs of the 4008, and the offset switch is fed into the "B" inputs of the 4008.

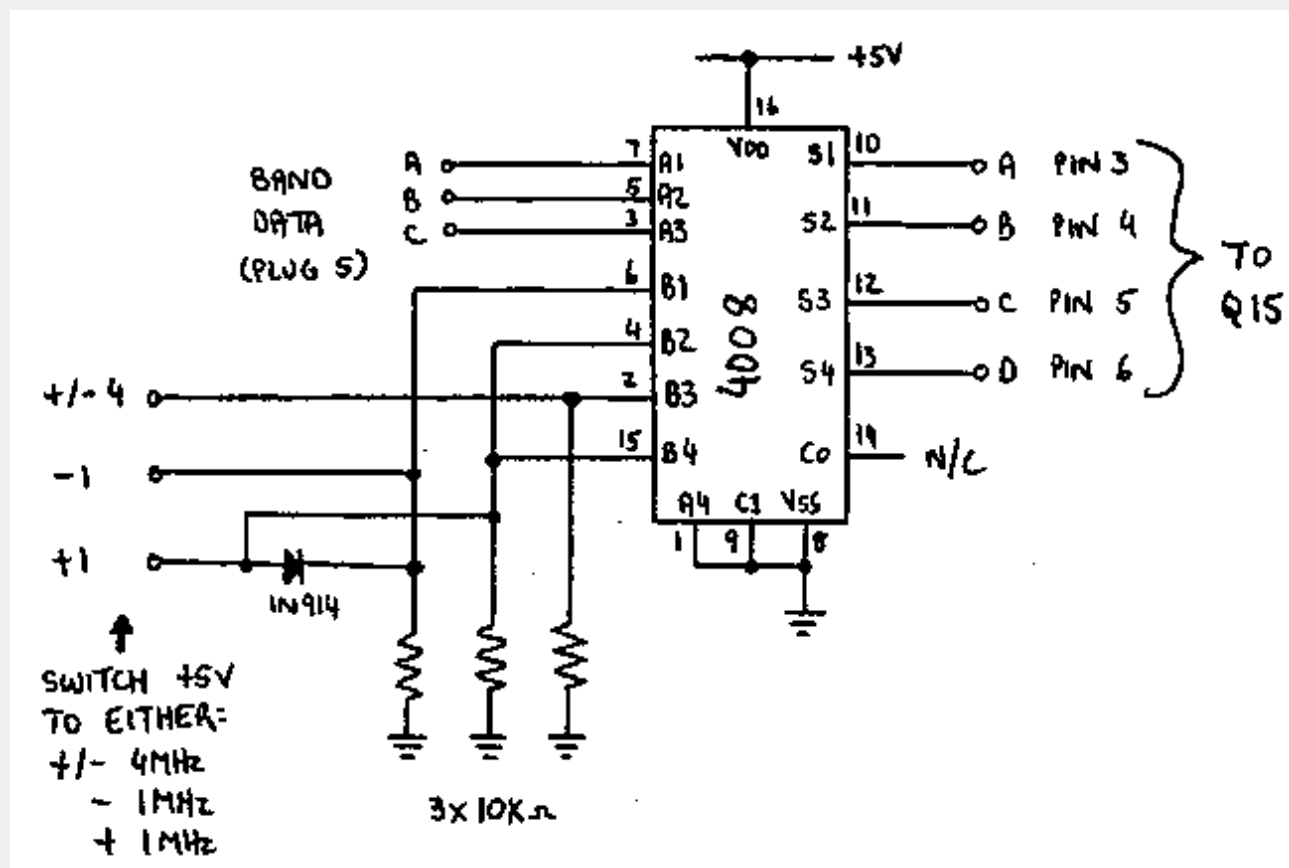

Results:

You may find that your VCOs (and there are three VCOs) don't remain locked over the entire range the logic is capable of. Improvements were made in my TS-660 by making the following changes;

1. 28MHz VCO - Replace C11 (27pf) with 56pf

2. 50MHz VCO - Add 22pf across C18 (18pf)

This scheme worked very well, and I added more features by upgrading to an EPROM based system. By using the "Hold" button and feeding TXB into the EPROM address lines as well as the band data and the offset data I introduced a "Repeater" and "Reverse Repeater" mode. This allowed me to run repeater mode without having to use both VFOs - very annoying! I could program the repeater output frequency into a memory and switch in the -1MHz offset when transmitting.

The complete PLL Unit Schematic:

Click on the picture below to see a larger image.

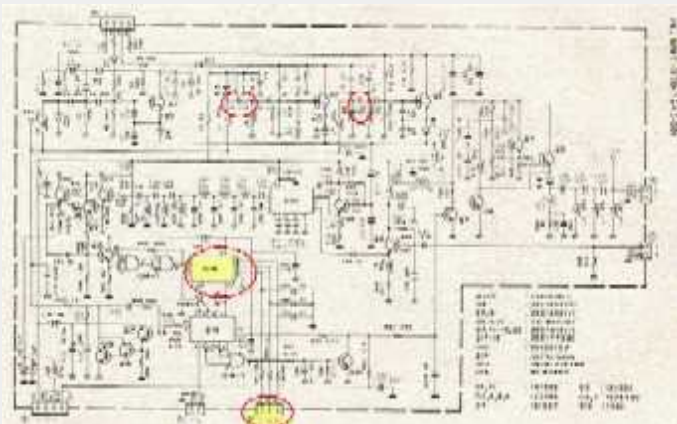

Thanks to <http://www.qsl.net/vk4cp/> for the modification.

This modification is read 672 times.

[top of page](#)

19-07-1998

(TS-680) TS680s Squelch mods - adds squelch to all modes

by Chris WB5ITT and Dave Underwood WB5HJV dunderwd@blkbox.com MODIFICATION.NET

Parts required

- 1 each 100 uF 20 v capacitor
- 1 each 10k ohm 5% 1/4W resistor
- 2 each 1N914 small signal diodes

Modification:

All modifications are to the signal board. Remove the signal board to gain access to the bottom of the board.

Remove R178 100 ohm resistor. (I cut the land between C177 and R178) (Removes FM chip control voltage) R178 is on the bottom of the board.

Add jumper with a diode in series between IC6 pin 14 and the base of Q57. Cathode of the diode goes to the base. (This is the squelch trigger control voltage) Q57 is on the bottom of the board.

Connect a diode between the 8V line (very near IC6) and pin 4 of IC6. This activates the FM chip (IC6) all of the time. Cathode goes to pin 4, anode to the 8 volt line.

Connect a 10 k ohm resistor between IC6 pin 4 and IC6 pin 14.

Connect a 100 uF 25 volt capacitor between IC6 pin 14 and ground. (This slows this quick squelch down a little bit) Tests have shown (using commercial communications monitor) that activating FM chip IC6 does not degrade IF strip performance at all.

I have had this mod in my 680 for a bout year and a half and is still working great!

Date: 25-10-2000

User comment

From: [Eric - WB4QOV](#)

Subject: More info

A schematic will aid in locating the area affected.

To perform the modifications you will need to open up the radio and split the halves (open it like a book) as the board you need to access is inside. Have the front of the radio facing away from you and remove the screws holding the signal board down. Unplug the antenna from the board (lower right) and also unplug CN27 from the 13 pin jack on the rear panel. This allows you to raise the board for access to the foil side where all the SMT parts are tacked on.

IC6 is located near the left middle of the board. Its pins are aligned from side to side on the board so it shouldn't be too hard to find.

Q57 is a surface mount component as are R206 (1k) and R205 (3.3k). These are located on the foil side of the board near the lower left corner close to the front panel. By referring to the SMT resistor code you should be able to find the three of them eventually. The base of Q57 is connected to a pad with R147 (1k) and R207 (10k). This is where you can connect the diode in the modification.

You can obtain the 8 volts DC from CN9 (pin 1) on the signal board. Reverse the assembly procedure to reassemble the unit.

It goes without saying that this modification might void the manufacturer's warranty but not having to listen to the background noise is well worth it!

This modification is read 721 times.

[top of page](#)

19-07-1998

(TS-680) TS-680 6 Meter power output increase

Adjust VR15 (50M) control on the SIGNAL UNIT board while monitoring 6 meter transmit power output into a 50 ohm dummy load. I adjusted mine while also monitoring the ALC level to insure that I still had some ALC action. Using this method I have increased my 6 meter power output to approx. 25 watts.

This modification is read 835 times.

[top of page](#)

19-07-1998

(TS-680) Broadcast Sensitivity Modification for the TS680S / 140S

Author: Dave Underwood WB5HJV - dunderwd@blkbox.com. MODIFICATION.NET

Between .500 and 1.6 MHz attenuation is added to reduce front-end overload on the Broadcast band. Some of us BCB DXers find this a HIGHLY undesirable feature. If I want attenuation I will use the front panel switch. The following mod will restore the sensitivity -
Cut the land between IC1 pin 11 and R7 (SIGNAL UNIT, M54581P)

Cut the trace between IC1 pin 12 and R10

Add a small signal diode (1N914, 1N4148) between IC1 pin 11 and R7 (Cathode towards R7)

Add a small signal diode between IC1 pin 12 and R7 (Cathode towards R7)

Trace the lands from pin 11 and 12 of IC1 and you will find a good place (to the left of connector CN5) to cut these traces as well as pad to solder the diodes to.

This modification is read 729 times.

[top of page](#)

19-07-1998

(TS-680) TS680 Freq Extend mod

This mod will allow out of band transmit on the Kenwood TS-680-s.

Remove the bottom cover. In the middle of the board is a diode marked d-31 just clip it and reinstall bottom cover.

This will allow transmit from 1.6 MHz to 33 MHz and 49 MHz to 56 MHz.

This modification is read 961 times.

[top of page](#)

19-07-1998

(TS-690) General coverage transmisson modification for the TS-450 and TS-690

- A. Remove all screws of top and bottom case.
- B. Remove two screws of front panel (left and right top sie),and loosen two srews of front panel (left and right bottom side).
- C. Remove all screws of digital unit (X46-312X-XX).
- D. Cut the chip diode D27 (RL73) on digital unit rear side.

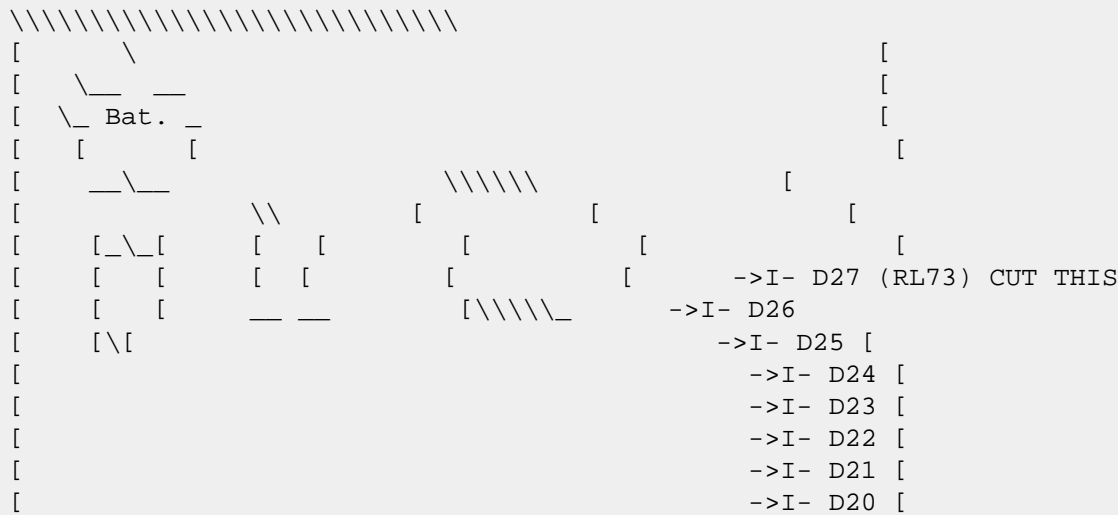

DIGITAL JNIT (X46-312X-XX) Component side view

Best 73 Eric St-Pascal Kam. Qc. VE2MEL

This modification is read 921 times.

[top of page](#)

20-02-1999

(TS-690) Micro-input RFI modification TS450-TS690 Kenwood

By Pedro M.J. Wyns, RF- and biomedical-engineer.

History:

After buying a ts690 I got considerable trouble with the vox circuitry.

The Vox gain was always too high due to an excessive feedback resistance in the vox amplfier. Apparently a PCB-mounting failure as the schematic carried the right value. After correcting this problem I still got RF problems with nearby antennas, blocking the transmitter in TX.

Problem:

lack of decent RF-filtering on the micro-input circuitry.

Solution:

adding ferromagnetic cores and adjusting rc-filters on the IF-board.

Action:

remove the connectors on the right hand side of the IF board (underside transceiver front towards you). Unscrew the board and fold over to the left. Add 22 nF parallel to R282 1k on t he micro entry close to Connector 6. Add 1nF parallel to C177 close to the IC-15 input. Add 1nF parall el to C217 close to the vox amplifier.

Remove te micro in and ground from the number 6 connector. Feed the white micro wire through a two hole ferrite core. Feed the inner conductor through a small ferrite core as well Reconnect...

If you might be using an MFJ (=major fucking junk) voice keyer, disconnect the shit-unshielded micro cable and replace by high quality twin balanced micro cable. Only use PTT, Mic and GND.

This concludes the mod. Don't even think of doing this without the service man ual and some smd-practice.

Good Luck

Pedro M.J. Wyns
Pedro.Wyns@emmaus.be
Moutstraat 7
B-2220 Hallaar
Belgium-Europe
Fax +32 15 303115

This modification is read 716 times.

[top of page](#)

26-09-1999

(TS-690) TS-690S 30KHz-60MHz RX

Hello all TS-690 owners. I finally found the mod I was looking for. I've never seen this mod anywhere before I suddenly found it on G4ICD web-site today :-)

TS690 Mods. Mods for your Kenwood TS690 - by Tuomu OH1LEU Six News.....

In issue 36 of Six News there was an article concerning the Kenwood TS690. A few questions were asked. I hope the following information will answer a few questions, including the 30KHz-60MHz coverage. I have a 690 bought direct from the States and my friend Kari OH1MLD has one bought from Finland.

We have been comparing the differences between models! All band assignments are controlled by diodes in the digital unit, which is located behind the front panel. There are several (probably) yellow 4148 look-a-like diodes in a row, marked D20-D23. D23 affects the rx range. Removing it opens the receiver from 30KHz (yes!) to 60MHz continuously. Also any frequency change can now be controlled directly from the keyboard. D20 may have something to do with the WARC bands, at least in the US model there is only one diode D21, so you might like to try taking others away. Also the logic changes when entering a new frequency because of the "new bands", so be careful when you decide to operate!

If you want to make these mods, take both covers off, note the extra filters which are now the highest parts of the rig and note also that those little flat cables coming from the digital unit can very easily break. After that, loosen two lower screws (on both sides) that are securing the front panel and take away the two upper screws. Now the front part can be twisted downwards. Diode D23 can be removed easily from the digital unit PCB, located at the right hand side. You may also like to make some changes to the mic gain scaling. It is very easy to overdrive the PA. Between the mic gain pot and the centre tap is a 10k resistor which causes the mic gain to be somewhat non-linear pot, but, if for example I had the mic gain at 9 o'clock now I can turn it to nearly 12 or even more. This is very handy when using the processor, the ALC setting is now not as critical.

The maximum gain remains the same. You may have noted that the AM band has poor sensitivity. You may change the coupling in the RF-unit on that particular band 500KHz-1.6MHz. The coupling has two 39 ohm resistors (R6, R7) in series, controlled through a 10 ohm resistor (R8) between them. Changing the 10 ohms to a miniature coil 1uH and those 39 ohms to 0 ohms makes AM sensitivity much better. If you live near an AM station forget this mod! The SMD components are located in the RF-unit, from the CN4 connector and IC2 towards the centre of the PCB, at the opposite end to the filters. I would recommend the purchase of a service manual before undertaking these mods. I can also not be held responsible for any damage Hi! 73 de Tuomo OH1LEU.

Note Cutting D23 reverts the 690 back to Japanese spec i.e. full Rx coverage up to 60MHz but only 50w o/p on 10m due to their regulations.

(Thanks G0HVQ)

There it is. I don't take any responsibility for any damages on your radio, or violation of any regulations. Perform the mods at your own risk. I haven't tested this myself. If you have any questions, I can't help you, I'm just relaying it off the internet. 73 de Andreas, LA8AJA.

This modification is read 845 times.

[top of page](#)

21-04-2000

(TS-690) TS-450/690 Calibration cable change

Author: Kenwood Communication, inc.

Service Bulletin no. 995 (11 May 1992)

The TS-450/690 may not calibrate properly against WWW (JJY) when using the calibration cable that is supplied with early versions of these sets, (serial numbers below 311xxxx) and when an antenna that is shorted for DC is used. A dipole with a balun is a prime example of a DC shorted wire. A minor circuit modification that adds a 100 pF isolation capacitor should also be performed. Please refer to the diagrams below for modification notes.

Parts required:

E37-0280-05	Calibration cable assembly	1 Ea.
CK73FCH1H101J	100 pF capacitor	1 Ea.

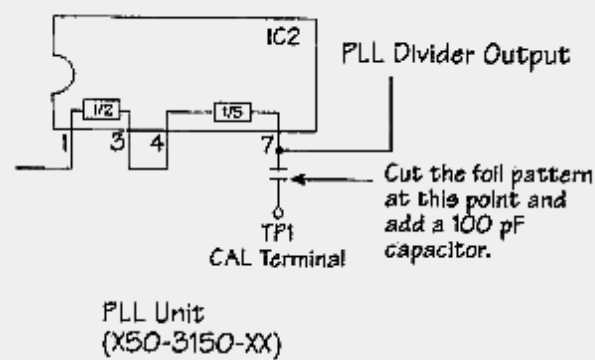
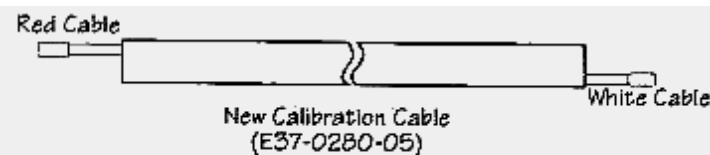

Time required for this modification is 30 minutes.

This modification is read 672 times.

[top of page](#)

22-04-2000

(TS-690) TS-450/690 Distorted TX w/TNC

Author: Kenwood Communication, inc.

Service Bulletin no. 1002 (18 November 1992)

Note: This bulletin supercedes bulletin ASB-994, dated 10 April, 1992.

We have received several reports of distorted transmitter audio when using a TNC controller such as the AEA PK-232 or Kantronic KAM, etc. The symptom will generally disappear if the transceiver and TNC units are powered from different sources.

Cause:

The audio output level from the TNC is generally too high and causes overload of the microphone amplifier circuit. In previous models such as the TS-440S the incoming TNC audio was inserted after the microphone amplifier. With the TS-850S it is inserted before the microphone amplifier. Just moving the insertion point to the output of the circuit is satisfactory since the drive level for FM packet is higher than that required for SSB.

Procedure:

1. Add a 10 dB attenuator to the PKD line on the IF unit (X48-3090-XX). This will prevent overmodulation of the microphone input circuit.
 - a. Change chip resistor R233 from 10 Kohm to 18 Kohm (RK73FB2A183J)
 - b. Change chip resistor R234 from 1 Kohm to 8.2 Kohm (RK73FB2A822J).
 - c. Delete chip capacitor C173 (100 pF) and add chip resistor R299, 1.5 Kohm (RK73FB2A152J).
2. Add the following note to page 35 and 37 of the Instruction manual.
3. When adjusting for proper ALC levels with an AFSK RTTY terminal or Packet TNC terminal you should adjust VR-13 on the IF Unit for a reading similar to the one shown in the accompanying diagram.

Note: The transceiver and RTTY or TNC terminal should use separate power supplies, in order to prevent RFI (Radio Frequency Interference).

Caution: This modification requires soldering equipment rated for CMOS type circuits. It also requires familiarity with surface mount soldering techniques. If you do not have the proper equipment or knowledge do not attempt this modification yourself. Seek qualified assistance.

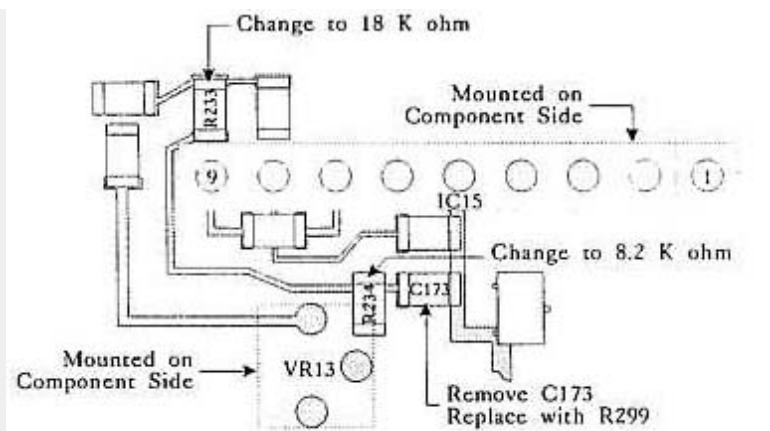

Part of
IF Unit X48-3090-XX
Foil Side View

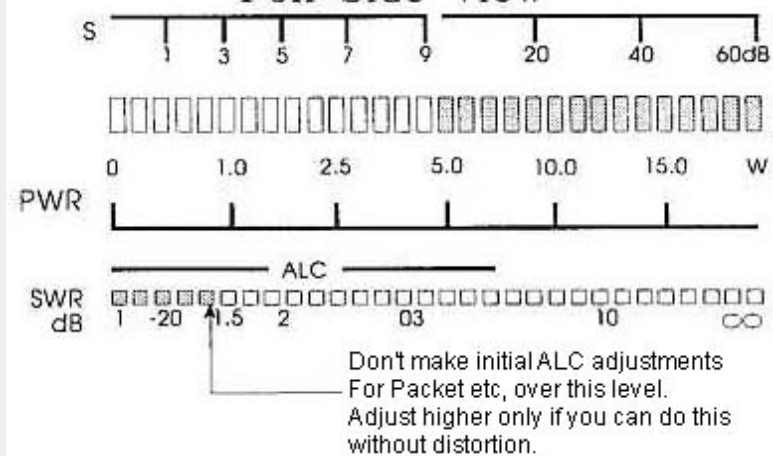

Time required for this modification is ½ hour or less.

This modification is read 658 times.

[top of page](#)

23-04-2000

(TS-690) TS-450/690 Low mic gain w/DSP-100

Author: Kenwood Communication, inc.

Service Bulletin no. 1032 (9 August 1993)

Symptom:

Proper microphone gain/ALC readings cannot be obtained unless the user adjusts the TX GAIN potentiometer on the rear of the DSP-100. This irregularity is caused of the DSP-100 MIC amplifier (IC-5).

Corrective action:

Remove capacitor C200 from the IF unit on the transceiver, and replace it with R300, a chip jumper wire.

Parts required:

Qty	Description	Kenwood Part No.	Circuit description
1	Chip jumper	R92-0670-05	R300

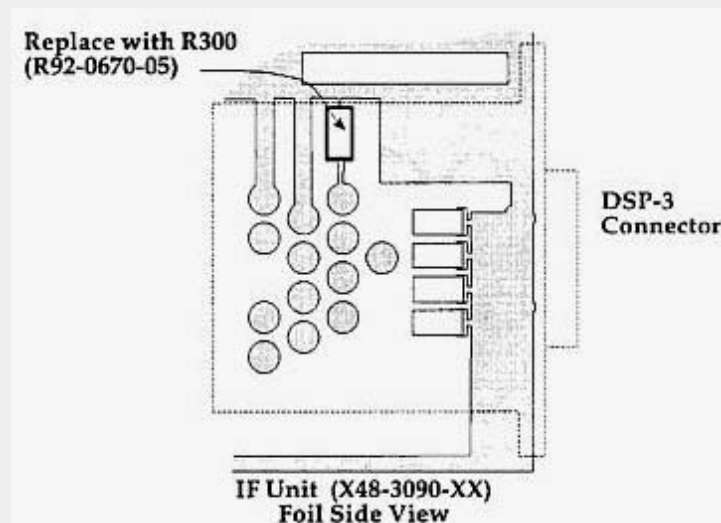

Caution: This modification requires soldering equipment rated for CMOS type circuits. It also requires familiarity with surface mount soldering techniques. If you do not have the proper equipment or knowledge do not attempt this modification yourself. Seek qualified

assistance.

Time required for this modification is 1 hour or less.

This modification is read 680 times.

[top of page](#)

23-04-2000

(TS-690) TS-450S/690S Noisy encoder

Author: Kenwood Communication, inc.

Service Bulletin no. 1059 (7 July 1994)

Symptom:

When tuning the Main Encoder of the TS-450S/690S with bare hands you may encounter a "scratching" noise in the speaker if an antenna with a high SWR is used. If gloves are worn no problem is encountered. This occurs because the shaft of the encoder is not grounded.

Countermeasure: Replace the Main Encoder with one that has a grounded shaft.

Parts required:

Qty	Description	Part No.
1	Main encoder	W02-1836-05
2	Mounting screws	N90-3006-46

Note: You must use the new mounting screws listed above with the replacement encoder.

Time required for this modification is 30 minutes or less.

This modification is read 679 times.

[top of page](#)

23-11-2001

(TS-690) Kenwood TS-690 30KHz-60MHz RX without modding

Author: Andreas, LA8AJA - la8aja@c2i.net. MODIFICATION.NET

I discovered another way to open up the RX.

You only need to hold down 2 buttons each time you turn on the radio. You have to do this each time, else the radio will reset itself. You can edit menu's and stuff.

This will be saved, but unless you hold in the two buttons each time you turn on the radio, you'll get a full reset.

It is the M>VFO and SCAN at the same time.

Andreas, LA8AJA

This modification is read 785 times.

[top of page](#)

19-07-1998

(TS-700) 9600 and TS-700a

1st March 1991

I connected the 9600 baud input directly across R21 (33 kilohm) on the Generator Unit Board via a 10 microfarad tantalum capacitor. The + of the tantalum is connected to the junction of C23,R21 and R22.

The - of the tantalum goes to the conductor of the shielded cable, and the earth shield to the immediately adjacent earth terminal. I carefully scraped off the 'insulation' on the top of R21 (approx 5mm) and soldered the + of the tantalum to it.

The 10 microfarads was basically for isolation. I originally intended to match the load as per James Millers article by modifying C34, however I just adjusted VR1 and because it works like a charm I have never bothered to attempt matching.

I have also been meaning to run the JAS-1 via the varactor for Fuji-Oscar 20, but once again have not got around to it. With the launch of all the Digital Satellites, time just seems to fly, especially when we have daylight saving, as the first evening pass goes by between 11pm and 12 midnight. Just lately I have been going to bed at a respectable hour, hence the delay in answering. However this weekend Daylight Saving finishes, so UO_14 and AO_16 will be here 'an hour earlier', which will be just great.

Trust the information is what you require. The 'old' TS-700a at this QTH is a very reliable and whats more one of my 'very sentimental' pieces of equipment. Do not think I could ever part with it. HI!!!!

73 from "down under". de Colin VK5HI.

This modification is read 857 times.

[top of page](#)

19-07-1998

(TS-700) Service notes on TS-700A

Author: Trio-Kenwood Communication, inc.

Service bulletin no. 20 (18-10-1977)

Power supply

1. 9 volts down: The MFC4060 Q11 and 2SA495 Q9 are bad.
2. No 21V: Replace Q3 (2SC733Y (X43= 1120-00) Power Supply Unit.
3. Dial light is VERY bright: Replace shorted Q2 2SA671 on rear panel.
4. Intermittant +9 volt supply: The legs of Q12 2SD235 are too short at the PC board. The leads were pulled away from the board. Replace Q12.
5. Power supply intermittant when tapped: Check for short leads on pass transistors, pulled out of circuit board.
6. No RX - No TX: Check diode D6 Zener in power supply. -6V supply. If shorted, replace.
7. No 13.8 volts at power supply: The wire on bridge D1 is not soldered.
8. +9 volts is okay, but 21 volt onl 16 volts: Q1 is bad in the power supply 2SC733Y.

TRANSMITTER

1. No modulation: Replace bad diode D15 Varactor on X52-1080-21.
2. USB or LSB is too high frequency: Recheck alignment of carrier board according to TKC service Manual procedures.
3. No RF out AM CW SSB: Replace D13 on GEN unit X52-108021.
4. FM RX and TX different frequency: Readjust all HET unit frequencies. Also check VFO linearity and adjust TX frequenc L3.
5. TX wrong frequency: Adjust L3 at X52-1080-21. 10.7 oscillator for final TX frequency.
6. No power out FM: Check for loose connection at L3, the 10.7 coil on GEN unit X52-1080-21.
7. No TX or RX: The fixed channel switch is in the wrong position.
8. Low poer out only 8W. 21 volt supply down to 16V: The protection diode D7 in the power supply is shorted.
9. VFO drift: Q1 3SK22Y in VFO is bad.
10. No TX FM: D15 on X52-1080-21 GEN is bad.
11. Drive control does not peak: This is normal - leave at center 500 position.
12. No TX: TX B terminal touch to ground at X52-1080-21 GEN unit.
13. No TX FM: Check diode D16 on GEN unit.
14. Only 3 watts out: Bad Q2 2N5642 in final amplifier.
15. The RF meter doesn't Work, but TX output okay: Bad diode D1 on BPF, the 1N60 is open.
16. No TX: Bad Q3 in mixer unit (X48-1130-21) 3SK35 (BL).
17. No VFO output: Cold solder joint of R2, 100 ohm resistor inside VFO on circuit board.
18. Intermittant TX: Bad ALC pot on mixer board VR2 (X48-1130-21)
19. No TX 147 Simplex: Loose resistor not soldered on rear circuit board of band switch.

Receiver

1. Spurious signals on receive; if the output level or VFO is too high or mixer Q3 on HET unit: SN76514 is bad.
2. IF the noise blanker does not work: Check Q6 2SK19GR on X55-1120-00.
3. There is no audio from receiver-no 21 volts: Q1 2SC733(Y) in 21 volt supply is bad.
4. FM receiver sensitivity is down 30 - 40 db: Check 10.245 xtal at TP-1 on FM IF unit. If oscillator level is down, replace crystal.
5. Receiver sensitivity is intermittant and TX intermittant: Check contacts RT relay. Replace if bent or miss-contact.
6. If you cannot adjust the center meter: Maker sure Smeter start, VR4 is set at zero. If you cannot get enough adjustment with center meter, adjust VR1, replace Q4 (2SK19GR) on X55-1120-00.
7. No receive: Check for solder touch at 133 terminal on Het unit, if ther is no 133 het output.
8. No RX or TX and no VFO light: Check diode D2, 1N60 located on VFO circuit board.
9. VFO drifts or moves wit shock: Wire is not soldered VFO main coil L1.
10. No repeater operation: Check for wire that is touching at repeater switch.
11. No receive: Resistor R7 is touching Q1, 3SK41 on X55-1120-00 board.
12. No RX on 144, or any single band: Check HET xtals-realign the Het unit.
13. Center meter drifts for the 300000series and before: Send for the TKC bullent on Center Meter Drift.
14. VFO is intermittant when turned: There is loose tension on VFO rotor and Stator plate contact. Rebend tension spring.
15. RX audio output distorted: Chec Q4 on X49-1060-00.
16. No SSB or CW receive: Resistor R73 is touching to the can of T6 on X52-1080-21.
17. FM receive okay but SSB sensitivity is down: Check alignment of SSB IF transformers T4,5,6.
18. FM receive is bad: Bad T1 on the X48-1140-20.
19. Scratchy audio with internal speaker: Check for bad speaker.

20. No 146 band: Replace bad Het Xtal on Het Board.

This modification is read 933 times.

[top of page](#)

12-02-2000

(TS-700) TS-700A for Repeater operation in Europe

Author: Trio-Kenwood Communication, inc.

Service bulletin no. 5 (June 11 1975)

We have had several inquiries about repeater operation of the TS-700A in Europe. The 2 Meter band in Europe is 144 MHz to 146 MHz with repeater operation in the 145 MHz to 146 MHz range. The repeater offset is generally 600 KHz down from the output frequency. The repeater offset in the TS-700A occurs only in the 146 MHz and 147 MHz bands. By changing these to 144 MHz and 145 MHz, respectively, and changing the appropriate offset, the TS-700A can be used with European repeaters.

The TS-700A uses varicap diodes to tune the HET unit, MIX unit and RX NB unit because of the 4 MHz coverage. These varicap diodes are used to resonate various stages, precluding the need to retune from band range to band range. The varicap diodes are biased by resistors that are selected by the Band and REPEATER switches. These bias resistors must be changed if the band frequency and/or offset crystals are changed. The table below shows the resistors and crystals that need to be changed to make the TS-700A useable with European repeaters. All resistors are 1/4 watt.

HET UNIT

Part No.	145-147 MHz	144-145 MHz
X3	127.100 MHz	125.100 MHz
X4	128.100 MHz	126.100 MHz
X6	128.700 MHz	125.500 MHz
R31	62 K	39 K
R32	82 K	47 K
R34	100 K	39 K

BAND SWITCH UNIT

Part No.	146-147 MHz	144-145 MHz
R103	12 K	22 K
R104	8.2 K	15 K
R110	12 K	15 K
R112	6.8 K	Delete
R113	6.8 K	18 K
ADD		138 K

It is necessary to remove the front panel to make this modification.

To do this, remove the top and bottom cabinet halves. Next, remove the FINAL tuning shaft by loosening the shaft coupling and pulling the knob and shaft out. Then, remove the six screws (3 on each side) holding the front panel. Remove the BAND and DRIVE knobs and the nuts holding these controls. Gently pull the front panel out until there is enough room to work on the BAND SWITCH unit.

The 138 K resistor that is to be added consists of a 120 K resistor and a 18 K resistor in series. It is connected from pin 3 of the band switch to ground. Show below is a diagram of the BAND SWITCH unit.

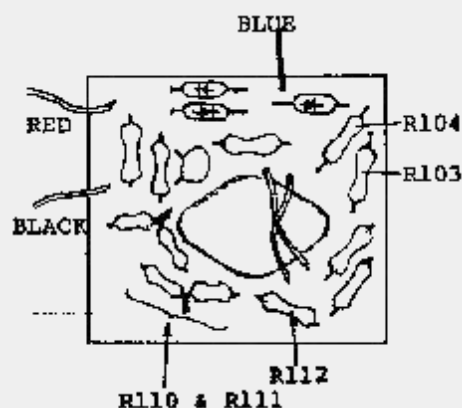

After installing the new resistors in the BAND SWITCH unit, reassemble the front panel, leaving out the FINAL tuning shaft. The

procedure for replacing the resistors in the HET unit is to first remove the three screws holding the board and tilt it up towards the VFO. Plugs P-1 and P-2 may be removed if necessary. The resistors that need to be changed are located on the outside edge of the board. Replace the resistors and reinstall the board and connectors. Install the crystals in the appropriate sockets (X3, X4, and X6). Replace the FINAL tuning shaft and align as per page 40 of the Service Manual.

This modification is read 788 times.

[top of page](#)

19-02-2000

(TS-700) Replacement of 9V regulator IC MFC.4060 with improved MC1723CL-A

Author: Trio-Kenwood Communication, inc.

Service bulletin no. 27 (28-12-1977)

X43-1250-00 PCB comes complete with mounting hardware and extended leaded leads for easy installation. Procedure:

1. Remove old IC MCF4060-A Q11.
2. Remove R27 1.5Kohm (Delete). Replace with wire jumper.
3. remove and reinstall R28 1Kohm on foil side of PCB.
4. Mount PCB per illustrations (observe lead call-outs between X43-1250-00, new PCB, and old Q11 position (X43-1120-00).
5. Reset VR1 for 9.0V measured at power supply output terminal.
6. Reset VR2 for 21.0V measured at power supply output terminal.

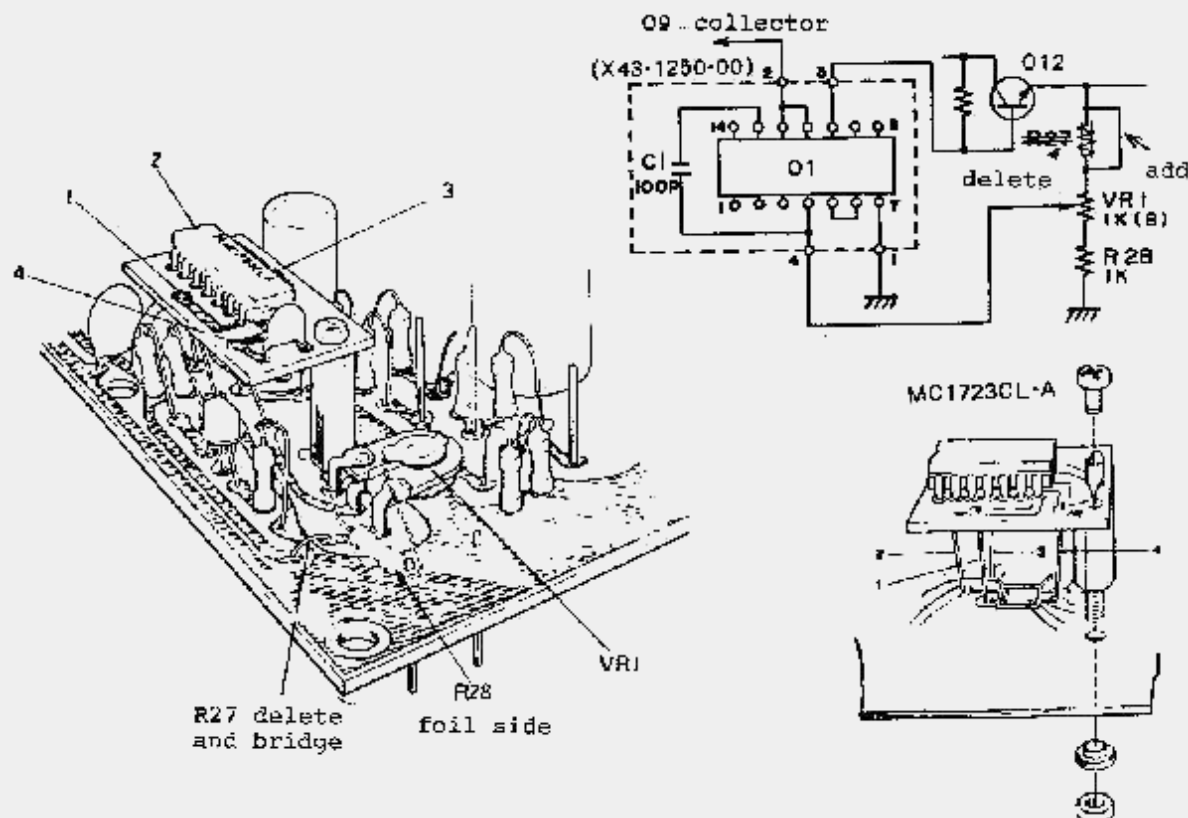

This modification is read 799 times.

[top of page](#)

02-09-2000

(TS-700) TS 700 CW QRG same as USB

Author: Henk - PA0CIS - pa0cis@amsat.org. MODIFICATION.NET

The TS 700 uses LSB when generating CW. This is quite annoying because when you would like to call a SSB station (which will always be using USB) you are unable to listen to this station while in CW-receive position. This happens quite often on 23/13 and 3 cm for which I use the TS 700 as exciter.

A cumbersome switching is the result.

This modification allows to receive in the USB mode of operation, while in CW.

Steps to be taken :

- Remove the bottom cover
- Locate the CAR VOX unit
- Locate the wirewrap-pin USB (first pin, close to var. C)

- Locate L1, 1mH, green, which is connected to USB pin
- Cut the L1 connection on the pin-side, leaving a wire as long as possible on L1
- Connect a diode (1N4148) between the pin and L1, the cathode connected to L1
- Locate the wirewrap-pin CWR (fourth pin, counting from var. C)
- Locate diode D10, close to pin CWR
- Cut the cathode wire of D10, leaving as much wire on the diode as possible
- Connect the cathode of D10 with the cathode of the added diode at the USB pin

The result is that CW is now received in the USB mode CW transmit is unchanged.
The frequency read-out is incorrect, this will be adjusted later!!

The CW transmit frequency must be shifted

- Locate var. C, TC 3, which is in the corner of the PC board.
- Connect 150 pf parallel to TC3, using its solder pins as connection points.
- Frequency adjustment (the simple way, not using measuring equipment):
- Take a second TRX
- Transmit CW in a dummy on 144.100
- Receive the transmitted signal on the TS 700 and adjust for a audio tone of 900 Hz
- Switch the second TRX to RX ; do NOT change the frequency
- Key the TS 700 with CW and adjust TC3 to get the correct audio tone on the second TRX (400-900HZ, depending on its filter)

Frequency readout

- Locate the counterunit
- The short end of the PC board has 4 var. C's
- On the PC board side of these C's locate a connector as far in the corner as possible
- The second wire of this connector is a blue one
- Cut the wire approx 4 cm away from the connector
- put a crimpsleeve of 2 cm over one of the wire-end (do not crimp yet)
- insert a diode in the wirecut, the cathode facing the connector
- locate D1, which is close to the middle of the connector
- cut the cathode side of D1 , leaving as much wire on the diode as possible
- connect the D1 cathode with the cathode of the inserted diode (blue wire)
- place the crimpsleeve over the blue wire diode + wire connection and crimp
- Switch the TS 700 to FM
- Adjust the frequency to 144.100.0
- Switch to USB, the readout should be 144.098.5, if not adjust TC 4 on the counterunit (TC4 is mounted on the PC board side opposite the connector and stands a little bit to the middle)
- CW and USB readout should be the same in receive

Switch to CW transmit. The readout should be 144.099.4. If not adjust TC 2 (second var C from connector).

Switch to LSB, the readout should be 144.101.5 if not adjust TC 1, closest to connector.

(For proper adjustment refer to the servicemanual and use a frequency counter).

Replace the bottom cover and enjoy SSB/CW or CW/SSB QSO's without difficult switching procedures.

73
Henk PAOCIS

This modification is read 774 times.

[top of page](#)

20-04-2001

(TS-700) Distorted mic signal for TR-7200G & TS-700

Author: Trio-Kenwood Communication, inc.

Service bulletin no. 23 (31-10-1977)

Receiver

1. No squelch: Check C84 47uf on X55-1110-11.
2. Intermittant receive: Check for D14 touching to ground on X55-1110-11.
3. Both Q17, Q18 audio transistors burned up: Send for bulletin before replacing.
4. Poor receiver sensitivity: Check for proper output of Q10 10.245 MHz stage. If it is defective replace xtal.
5. No receiver audio noise: Check L23 discriminator coil.
6. No receiver: No C9 voltage at X55-1110-11.
7. Receiver sensitivity poor: Check D2 MI301.

Transmitter

1. Distortion on audio TX: Bad Q8 TA7061 IC.
2. No TX HI: Check for shorting terminals at HI/Low switch.
3. No TX: Check for proper T9 voltage at X56-1190-11.
4. No TX: Collector voltage SB at X45-1080-00. Check Q9 2SA496Y.
5. No TX: Check D1 MI301.

Date: 20-04-2001

User comment

From: [Jan Steen PA3FTD](#)

Subject: TS-700 noisy

The problem, as described for the TR-7200G (distorted mic.signal) can also be applied for the TS-700, which uses the same mic. preamp TA7061.

The signal sounds ugly noisy. The replacement of the preamp was efficient. I discovered it myself and used the preamp from an old 7200.

This modification is read 769 times.

[top of page](#)

14-09-2001

(TS-700) Put CW on USB for the Kenwood TS-700A, S, SP

WOPN/4
6/14/77, 4/3/96, 7/11/00, 9/10/01

The following paragraph is an excerpt from my letter to Kenwood (which received no response, as expected):

"Why did you put the CW carrier on LSB in the TS-700? This design quirk is creates mass confusion and operating inconvenience for all your TS-700 customers. Picture the following: you are calling a weak distant station on CW, which means you are automatically transmitting and receiving in LSB mode... the called station answers, but on SSB. You will probably not even hear that response; in any case, the response will at best be unintelligible, since you are in LSB mode and the other station is in USB mode, which is the convention on all amateur bands above 14.0 MHz!"

Readers, take heart! This design flaw is easily corrected in 30 minutes with a simple modification requiring only one additional switching diode which relieves the problem by putting CW on USB, producing an 750 Hz note in any other transceiver operating in USB mode which is tuned to the same frequency as the one which is doing the transmitting. Additionally, it does not affect compatibility with unmodified transceivers.

Steps 1 - 5 below apply to the 700A CARRIER board, or the 700S/SP CARRIER-VOX board.

1. After sufficient warmup of your frequency counter and the TS700x, record the frequency of the generated carrier in all modes by connecting the counter to the TP (Test Point) following the buffer Q2 (700S/SP = Q11). **The following listed frequencies are from my TS700A and are provided as an example only:**

USB	10.698558	Note: Make certain an open circuited key jack is inserted to prevent
LSB	10.701525	transmitting a carrier which could affect counter readings.
CW-tx	10.700775	
CW-rx	10.701525	

2. Interchange crystals 'X1' and 'X2'. Unsolder one end of C3 (700S/SP = C23) and ensure it does not short to adjacent components... it will be left permanently disconnected.
3. Interchange one end of L2 and L3 by lifting the wire from their respective terminals and installing criss-cross jumpers.
4. Interchange the wires to the USB and LSB connection posts on the board... there are 2 wires on each post.
5. Adjust the oscillators to the relative frequencies shown, using the trimmers indicated. USB and LSB are to be adjusted to the original frequencies recorded in step 1, and CW-tx is to be adjusted to be 850 Hz higher than the USB frequency. CW-rx will be identical to USB and requires no adjustment.

USB	10.698558	adjust TC3
LSB	10.701525	adjust TC1
CW-tx	10.699308	adjust TC2
CW-rx	10.698558	requires no adjustment

This completes the modification for the TS-700A

Correcting the frequency readout on the 700S and 700SP:

After sufficient warmup of the transceiver, perform the following steps on the 700S/SP COUNTER board:

- a. Cut the PC trace at the USB post. Bridge a 1N914 (or equivalent) diode across the cut with the anode toward the post. This diode will be referred to as D4a.
- b. Disconnect the cathode end of D1 from its current position and reconnect it to the cathode end of the newly installed D4a.
- c. Place the transceiver in USB mode and note the dial reading. Switch to CW mode, place in the transmit condition (make certain than an open-circuited key jack is in place in the KEY jack) and adjust TC2 on the counter board for a reading 750 Hz higher than the USB reading just noted.

Note: on some 700S/SP's, it may be necessary to disconnect one end of C16 and place a 10pF capacitor in series with TC2 to achieve your goal. Otherwise, settle for the same readout as that shown in USB mode. Some 'X2' crystals just won't pull quite far enough for +750 Hz.

This completes the modification for the 700S/SP

This material is presented for your personal information only... no guarantees, warranties or other messy things are either expressed or implied. This modification has been installed by hundreds of VHFers worldwidewith no problems reported to date.

Note: The absolute accuracy of the frequency counter used is not overly important ... most important is the relation of the frequency measurements, therefore, the counter should be powered on, allowed to warm up sufficiently to eliminate drift and left on during this entire process.

15-12-2001

(TS-700) Modifikationen für Kenwood TS-700

Author: Lothar, DF5JG - loliri@t-online.de.MODIFICATION.NET

Lieber OM,

ich bin auf Ihre Internetseite www.mod.dk gestoßen und finde Sie hochinteressant. Ich habe für meinen TS-700 seinerzeit die Umbauvorschläge gesammelt, die in der Zeitschrift cq-DL veröffentlicht wurden. Da ich die Rechte an diesen Veröffentlichungen nicht habe, will ich Ihnen wenigstens durchgeben, was wo zu finden ist.

- a. Mithörton bei TS-700G, cq-DL 9/1982, Seite 428
- b. Stufenlose Leistungsregelung beim TS-700G, cq-DL 11/1980, Seite 507
- c. Digitalanzeige für TS-700(G), cq-DL 7/1978, Seite 313
- d. Verbesserungen am TS-700, cq-DL 5/1977, Seite 198
 - A. Verbesserungen der Nebenwellen-Empfangsfestigkeit
 - B. Verbesserung der Wirkung des Noise-Blankers
 - C. QRP-Schaltung
 - D. Verwendung von 27-MHz-CB-Quarzen im Fix-Channel-Oszillator
 - E. Tonruf
 - F. Relais-Shift und Relais-Shift invers
- e. Verbesserungsvorschläge zum TS-700, cq-DL 1/1977, Seite 18
 - A. Allgemeine Beschreibung
 - B. Eichmarkengeber mit 10 kHz-Punkten
 - C. Roger-Piep für SSB-Betrieb
 - D. Repeater reverse (Umsetzer verkehrt)
 - E. Verbesserung des FM-Empfanges
 - F. Stufenlose Leistungsregelung
- f. Der Dynamikbereich von 2m-Geräten
 - A. Teil 1: Einführung, UKW Berichte 4/1981, Seite 228
 - B. Teil 2: Verbesserungen des TS-700, UKW-Berichte 4/1981, Seite 236
 - C. Nachtrag: Verbesserungen des TS-700 lt. UKW-Berichte 4/1981, Seite 236, UKW-Berichte 2/1982, Seite 124

Ich hoffe, ich konnte etwas zur Webseite www.mods.dk beitragen.

Ich wünsche Ihnen ein frohes Weihnachtsfest.

vy 73 de Lothar, DF5JG

19-07-1998

(TS-711) General coverage xmit - TS-711

1. Remove the top cover and locate the control unit (X53-1410-XX)
2. Cut diode D30, xmit now 141.000 TO 150.995 MHz.

This modification is read 927 times.

[top of page](#)

19-07-1998

(TS-711) 9K6 baud modifications for KENWOOD TS-711 & TS-811

The following modifications, while not guaranteed certainly work on my radios:

I do not use the ACC 1 Connector on the back panel so I have removed the plastic plug and mounted a five pin DIN socket, although you can use any socket that fits.

The requirement for the 9600 baud modem is that transmit audio must modulate the varactor directly, and receive audio must come directly from the discriminator output, both these points are fairly easily accessible;

USE GOOD QUALITY AUDIO SCREENED CABLE FOR CONNECTIONS

1. Remove top and bottom covers of TS 711/811.
2. Turn set upside down and locate the PCB marked IF Unit X 48-1400-01 it is the large one on the left facing the rear of the set.

Mark, z11tre

RECEIVE AUDIO

1. Locate R 173 (3.3K), at the rear left side of the IF Unit PCB alongside a 1 ufd electrolytic capacitor (C 163). The connection to the discriminator output should be made at the junction of R 173, C 159, R 199 and C 163. I did this with a very fine tip soldering iron by soldering to the lead of R 173 nearest to C 163 although it could be soldered under the board if your iron is not small enough. The earth screen I soldered to a lug under the screw head located close by at the corner of the board.
2. Run the cable to the socket on the rear panel and wire as desired.

TRANSMIT AUDIO

1. On the same PCB at the front right (facing rear) locate R 11, mounted upright alongside J2 (4 way socket). Connection to the Varactor can be made at Pin 2 of J2 or as I did by carefully filing the lead of R 11 and soldering to it directly. The earth shield I soldered to a lug under the PCB corner mounting screw.
This earth is also available at J2 Pin 1.
2. Run the cable to the socket on the rear panel and wire as desired.
3. If you have a scope available, set the tx level to 1.5v P to P at position FMM. If no scope, set the tx level pot on the G3RUH modem to the 11 o'clock position and experiment.

UoSAT 3 only requires TX Audio from the 711 and RX Audio from the 811 but I would recommend wiring both in each set for future satellites such as RUDAK etc. You will also need to provide a Push to talk connection to your TNC either from the ACC 2 connector or mic socket. I wired from the back of the ACC 2 connector to the DIN socket that I mounted in the spare hole.

Good luck, ZL1TRE, Auckland, New Zealand.

This modification is read 682 times.

[top of page](#)

19-07-1998

(TS-711) To expand coverage to 141.0 - 150.995 MHz

Cut D34 on control unit, and then reset the microprocessor.

This modification is read 793 times.

[top of page](#)

31-03-1999

(TS-711) Betr.: 9600 Bd G3RUH-Modem an TS 711/811

de DC5KC @ DB0IZ

Liebe OM's.

Der Anschluss eines 9600 Bd Modems nach G3RUH an einen TS 711 bzw. TS 811 kann bekanntlich nicht ueber den dafuer vorgesehenen ACC2 jack erfolgen. Das TX AUDIO - Signal muss direkt an den FM - Modulator gelangen. Das RX AUDIO - Signal muss direkt am FM - Demodulator abgenommen werden.

Modulator. (TS 711/811)

Das TX AUDIO - Signal wird ueber ein abgeschirmtes Kabel und ueber einen 6,8 kOhm Widerstand an den Anschluss FMM gelegt. Der Widerstand liegt zwischen Kabelseele und Anschluss FMM. Der Anschluss FMM ist zu finden auf:
AF - UNIT, Stecker 4, Pin 3. (GND = Stecker 4, Pin 2.) oder
IF - UNIT, Stecker 2, Pin 2. (GND = Stecker 2, Pin 1.)

Demodulator. (TS 711/811)

Das RX AUDIO - Signal wird ueber ein abgeschirmtes Kabel am FM - Demodulator abgenommen. In der unmittelbaren Naehe des Steckers 9 auf der IF - UNIT befindet sich der Widerstand R 173 (3,3 kOhm).
Dort wo der Widerstand R 173 mit den Kondensatoren C 159, C 163 und dem Widerstand R 199 verbunden ist, wird die Kabelseele angeschlossen und mit dem RX AUDIO Eingang des Modems verbunden.

Abgleich.

Am Anschluss FMM sollen 1500 mVss sein oder alternativ vor dem 6,8 kOhm Widerstand entsprechend ca. 3200 mVss. Diese Werte werden mit dem Potentiometer VR1 auf dem 9600 Bd MODEM eingestellt.

Der Einfachheit halber habe ich diese Aenderungen (MOD. und DEMOD.) gleich an beiden Geraeten ausgefuehrt. Die genannten UNITS befinden sich auf der Unterseite des Geraetes und die entsprechenden Anschlusspunkte sind gut zugaenglich. Auf dem ACC2 jack habe ich fuer die Verbindung zum Modulator (FMM) den freien Pin 10 genommen. Fuer die Verbindung vom Deodulator nahm ich Pin 5.

Viel Spass beim Loeten und bei den QSO's mit dem G3RUH 9600 Bd MODEM.

73 und 55 de HB9MGI @ HB9AC.

This modification is read 639 times.

[top of page](#)

18-11-1999

(TS-711) IF Amp for TS-711A

Author: Chuck - KD9JQ - kd9jq@mc.net. MODIFICATION.NET

Add-On TS711A 1st IF Amplifier ~ 16dB Gain

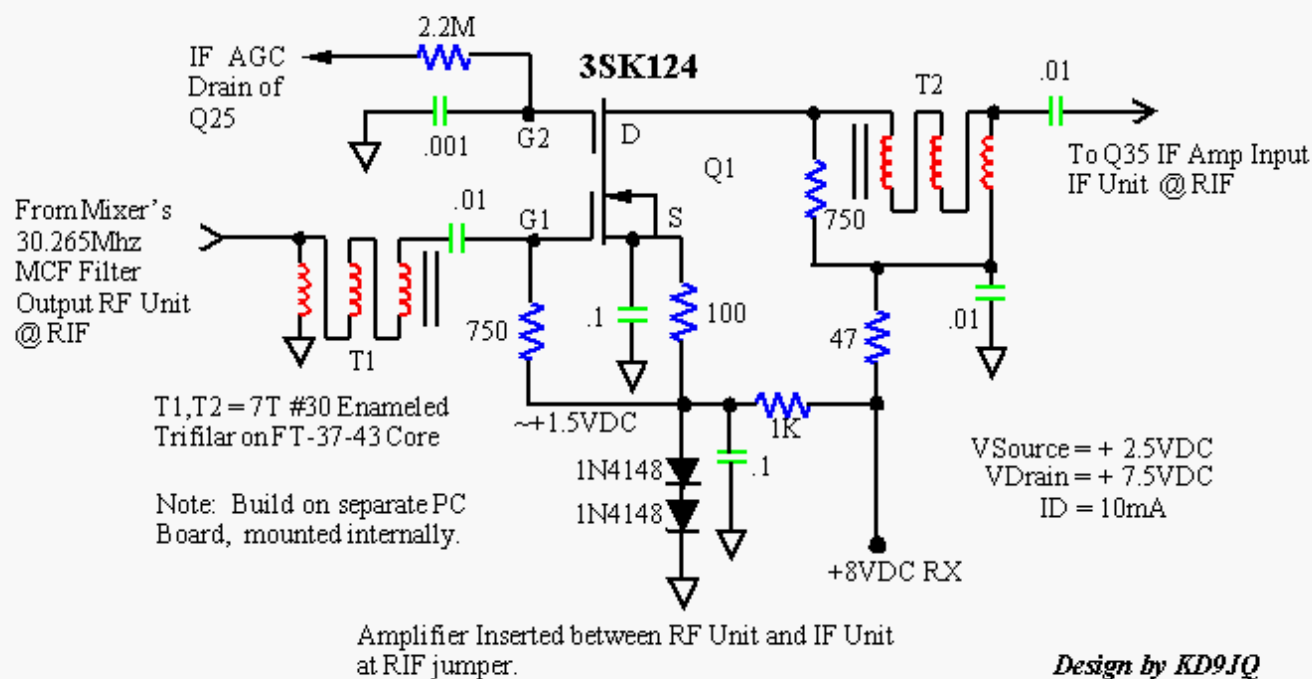

This modification is read 798 times.

[top of page](#)

19-07-1998

(TS-770) Modification Kenwood TS-770E for 9600 baud (G3RUH)

If you remove the small plate on the back of the unit you will find an easy way to mount an 9 pin sub d connector (at least on the "E" version) which has enough room for rx, tx and ptt.

You can get the signal output from the discriminator unit, plus side of C163 (on my rig this capacitor was mounted the wrong way round, I corrected this). The voltage is very low, so you may need some amplification - 10 in my case. C165 (22nF) on the output of the discriminator has to be replaced by 1.5 nF or 1nF.

The transmission signal goes to diode D47 in the modulator stage, a resistor of 10k in series. Check the output adjustment of your modem by using a second receiver. Adjust it that the modem noise is somewhat lower than the noise of the empty channel.

Use shielded cable for these connections.

The easiest way to find the ptt line is by looking at the microphone connector.

If you want to suppress "man made noise" over the possibly connected microphone while transmitting packet, you can short the microphone by using a reed relay. Then you have to connect the packet-ptt to the rig-ptt by using a diode to prevent shorting the mike on normal transmission.

Cause I experimented a lot with my rig I also replaced the IF-filter with a wider one. The built-in type CFW455E may work ok.

I didn't make a BERT, but there are very few retries using filter characteristic #1 on the 9600 modem of my TNC3S.

Martin DL2MGQ @ DB0KCP.#BAY.DEU.EU Bobingen, JN58KG

This modification is read 340 times.

[top of page](#)

19-07-1998

(TS-780) TS-780 für 9k6 baud

Hermann aus Stuehlingen (db7gv@hb9os) schreibt:

Ich habe dem Anschluss beim TS780 folgendermassen bewerkstelligt: Das Empfangssignal kommt direkt vom Diskriminator, vom Kreuzungspunkt R99,R100,R126. Am besten am "oberen" Ende von R99 abnehmen.

Das Sendesignal wird direkt in den VCXO eingespeist, und zwar am Kreuzungspunkt R199,R221. Auch hier wieder am besten am "oberen" Ende von R221.

Beide anschuesse findet man auf der IF-Unit, auf der Unterseite des Geraetes die groesste Platine. Den Demodulator fast genau in der Mitte, den VCXO 2 cm vom hinteren Rand entfernt, eigentlich innerhalb des Weissblechrahmens, doch der R221 ist ausserhalb.

Es funktioniert sehr gut, Messergebnisse liegen jedoch keine vor. Wuerde mich jedoch freuen, von Deinen Erfahrungen etwas zu hoeren. Wenn es auch bei Dir klappen sollte, waere es nicht schlecht, wenn man die Anleitung publizieren wuerde.

Soweit der Vorschlag von Hermann, den ich mit seiner Zustimmung publiziere. Otto (DK2QG) und ich (Wolfgang, DD7PQ) haben Ottos Transceiver nach dieser Vorgabe erfolgreich modifiziert und folgende weiteren Änderungen vorgenommen:

- Die Signale haben wir über RG174 an zwei freie Punkte der Mikrofonbuchse geführt. Die Schirmung darf selbstverständlich nur einseitig an Masse gelegt werden.
- Die Einstellung der Ausgangsleistung des Modem hat sich als kritisch heraus- gestellt. Sicherster Weg ist die Kontrolle durch eine Gegenstation. Einsatz des DF9IC-Modem
J5 TxNF unbedingt in Position 3-4 "PT" belassen, das ist die Voreinstellung. Begründung: siehe nachfolgend
- Einsatz des G3RUH-Modem
Beim G3RUH-Modem liegt die Sende-NF permanent am Ausgang des Modem an. Dies führt zu einer Rausch-Überlagerung des Empfängersignals. Abhilfe ist folgendermaßen möglich: Pin 20 und 22 des 27(C)128 werden zusammengefaßt und über 10 K an + 5 V gelegt. Dann wird eine Leitung zwischen Pin 20/22 des 27(C)128 des Modem und Pin 18 der Z80A SIO/O des TNC geschaltet. Zusätzlich können noch auf dem Modem die Pin 11,12,13,15,16,17,18 jeweils ueber 10 K an Masse und Pin 19 über 10 K an + 5 V gelegt werden.

Kommentare und eigene Betriebserfahrungen sind herzlich willkommen.

Wie ueblich, wird jede Haftung fuer den Umbauvorschlag abgelehnt.

Viel Erfolg beim erfolgreichen Umbau wuenschen

Otto, DK2QG und Wolfgang DD7PQ, Vorstandsmitglieder der IGPRMS e.V. (Interessengemeinschaft Packet Radio Muenster e.V.)

This modification is read 375 times.

[top of page](#)

19-07-1998

(TS-790) TS-790 mods.for G3RUH/TAPR-PSK

This short note is addressed to Paul DU1POL originally, but it may be help of them who has the same problem,I uploaded addressed To:All here.

Hello Paul
G3RUH 9.6kbps modem connection need mod. to both TX and RX. of 790.

TX.....
connect new 1kohm R to the point D81 and R358(1k ohm) OR connect to CONNECTOR-31 directly.

RX.....
IC8(MC3357P)---for main RX, IC1(MC3357P)---for sub RX pin #9 is the point to draw RX signal.

Usually, sub RX is used for satellite communication as TX/RX freq. is different. But I drew both main and sub signal and switch them with a microrelay.This relay can be controled with main panel SW 144ATT.(see 790 manual).

These mods. are essential for G3RUH 9.6kbps, but also usable for FO-20 PSK. BUT.....with my experience, there is many trouble to use this mods. for TAPR PSK modem. TX audio level setting, RX noise (MC3357P pin#9 has 455khz wave element).....and so on. So, I use ACC2 for TAPR PSK modem (also usable for 1200AFSK)

ACC2 connection
4---GND
9---PTT
11---TXD audio signal in
1 --3.3k---
3 --3.3k---/ connect together to RX audio.

two small 1/8w 3.3k regitor mixes main and sub audio, so it is able to use for cross band full duplex and mono band half duplex operation.
These registor can be mounted in ACC2 13 pin plug.

UP/DWN control from TAPR PSK modem to 790
U12 and JP5/6 setting

U12				790 mic terminal	
pin 8	----	D	-----	UP pin 4	
pin 5	----	E	-----	DWN pin 3	
	G	---	B	-----	GND line

pin 6 and pin 7 must be jumpered and connect to ground.

- R75 2.7kohm may be changed to 300-500ohm for steady photo couple.
- C32, C34 (10uF) must be changed to 3.3uF or 4.7uF for rapid doppler shift tracking.
- R7 in TX audio output circuit must be changed to 2.2Kohm as the original have heavy phase distortion. With this change, TX audio connection to mic (or ACC2) is no problem (no need dirct varactor feeding).

Mods. to audio drop problem in 790 computer control.

In computer control from rear ACC1 terminal,frequency setting command makes 10m sec.of audio drop(mute),and data collapse occur in PACKET operation. This problem is fixed by killing the blanking pulse to IF amp circuit. remove Q4(2SC2712) on IF unit and short the collector circuit to GND (R15 470 ohm).

This mods. is essential for auto freq. control with KCT/Tuner for low orbit Packet satellite.

This is all of my mods. to 790/G3RUH/TAPR-PSK modem
Best regards.
Sueo Asato
JA6FTL

19-07-1998

(TS-790) TS-790A for use with the paccomm MC-NB96 G3RUH

12-26-91

The Kenwood TS-790A makes a wonderful 9600 BPS Packet Radio Transceiver as it has an excellent front end, powerful transmitter, and 144,440, and 1.2 GHZ coverage. The CFW-455F filter inside is not too narrow despite what you may have read and coupled with the low noise front end of the rig enables the G3RUH modem to reliably decode valid data that barely moves the S-meter.

The modification discribed below is simple, reversible, and does not impair normal operation or the appearance of the transceiver. This is a "no holes" modification as it allows the G3RUH modem to be connected to ACC 4 jack on the rear panel.

Place the TS-790A upside down on a soft clean surface so as not to mar the cabinet. Remove the bottom cover to expose the IF Board. With the front panel facing you the work area is the upper left quarter of the IF board. Identify pin 9 of IC8 (MC3357P). There are two of these chips on the IF board but only the main demodulator IC is in the work area. RX audio to the modem will be derived from this point. Next locate J31 a two pin connector near D81 and X2 (10.965 OSC). TX audio from the modem will be supplied to the hot lead on J31.

Note the large aluminum heat sink that spans across the IF board near the rear of the chassis. A round lug will be mounted on it near the rear of ACC 4 jack.

Wire an eight pin din plug. Use shielded cable for TX and RX audio. No traces on the IF board need to be cut. Pins 3 and 5 of ACC 4 are not connected to anything as the radio comes from the factory. Make sure the Din plug fits the jack properly before wiring it.

PIN 2 - ground
PIN 3 - TX audio from G3RUH
PIN 5 - RX audio to G3RUH
PIN 8 - PTT

Prepare two six inch lenghts of RG-174. Prepare one end of each cable so that the shield will reach the ground lug mounted on the large aluminum heat sink. The cables will be routed over the top of the heat sink and will not be crushed when the bottom cover is reinstalled as there is adequate clearance.

Solder the center conductor of one cable to pin 3 on the rear of ACC 4 (verify with ohm meter). Solder the center conductor of the other cable to pin 5 on the rear of ACC4 (verify with ohm meter). Dress the cable connected to ACC 4 pin 5 over to IC8 pin 9. Cut to size and solder (be careful- use minimum heat and thin solder). The exposed shield is discarded and heat shrink tubing placed over the end to prevent any shorts that would otherwise occur from having exposed strands of the shield touching something. Dress the other cable connected to pin 3 of ACC 4 to J31 and cut to size. Prepare the end in the same manner as the other cable. Solder the center conductor to pin 2 of J31. This is accomplished by cutting the lead going to pin 2 about 1/2 inch back, stripping the insulation back 1/8 inch on the two ends, and then joining the center conductor of the cable going to pin 3 of ACC 4 and soldering the three exposed ends together. Use heat shrink tubing to cover the solder joint.

NOTE that the banded end of D81 is not the cathode of the varactor diode ! There is no need to insert any additional capacitance in series with J31 pin 2.

The shields are not connected at both ends of the RG-174 cables in order to prevent ground loops. The Aluminum heat sink was used as ground as no other ground was available that was close to ACC 4. Your sight may be better than mind and you may find one.

Adjust VR-1 on the MC-NB96 board for 75 mv p-p as measured on pin 2 of J31. This will give a good initial setting for injected transmit audio level.

This completes the modification. 9600 BPS Packet can now be enjoyed on each of the bands installed in your TS-790A. For non-packet operation either unplug the modem from ACC 4 or turn off power to the modem. For 9600 packet operation unplug the mic and turn the mic gain to minimum.

Thanks to Frank Anderson, W7ZTA and Jeff Angus, WA6FWI for their help. Please report any errors or suggestions to:

Mike Hooper
KF6PU @ WB6YMH.#SOCA

This modification is read 982 times.

[top of page](#)

19-07-1998

(TS-790) TS-790 & 9600 Baud Operation (Rev 2)

These notes were partly taken from James Miller, G3RUH notification for FT736R and the article of my good friend Sueo Asato, JA6FTL.

These mods are working very well with 9600 bps UO-14 and CBBS operation currently used at my site.

Please refer to G3RUH's notification for FT736R for more detail.
RX/TX mod suitability remains same as his notes.

TS-790 ; FM Direct from Discriminator

Detected and amplified/buffered FM direct from the receiver discriminator is available from Pin-9 IC1 (Sub) or IC8 (Main).
I use IC1 (Sub) for reception.

TS-790 ; Direct varactor FM Modulation

Inject your TX audio at the cathode side of diode D81 with a 1K ohm resistor in series. You can find D81 near Q73 in your IF UNIT diagram.

Misc

It takes a bit hard work for very small and jungle PCB. Use tiny tools.
Carefully adjust the TX audio level by VR1 of the modem, it's rather low.
You would probably need some local friend to do this adjustment, asking him to tell you his TNC's DCD LED stays steady (no flicker).

This modification is read 1019 times.

[top of page](#)

19-07-1998

(TS-790) UO-14 RX frequency tracking for TS-790/FT-736

The doppler shift range in overhead pass reaches to 20kHz. It is essential to tune-in RX frequency for good through put.
I assembled auto freq. tracking for UO-14 FSK signal reception and achieved good result.

[Block diagram]

RX discri.out<-- voltage comparater--INV--NOR--switching TR---> Down control
(Q1) (Q2) (Q2) (Q3)

G3RUH board DCD -----

[Circuit connection table.]

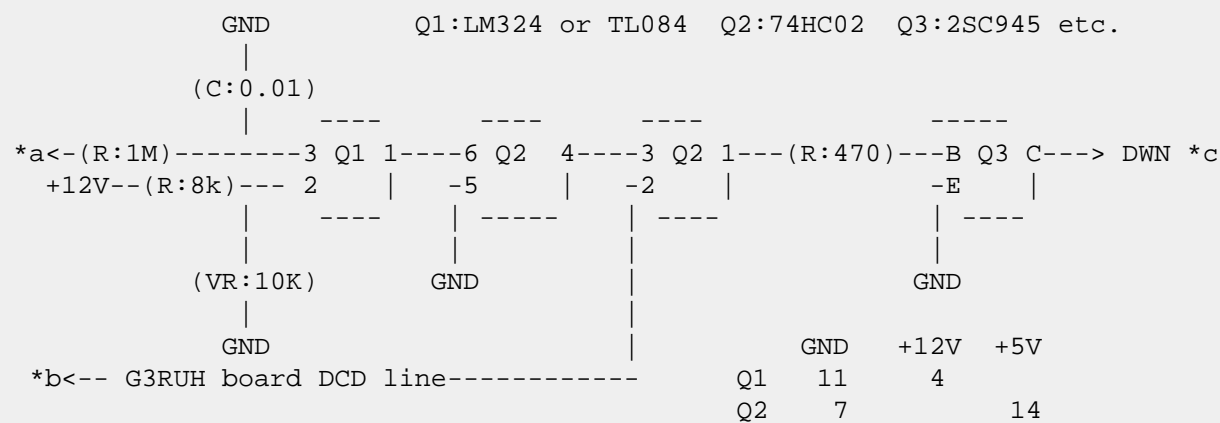

*a: to RX discri out (=G3RUH board RX IN)

*b: to G3RUH board DCD line (U10 pin 13)

*c: to down control pin of mic terminal (TS-790 mic pin 3)

setting of VR:10k

The discriminator IC output level is 5.8V+-2V.

Whitout RX signal, set the VR to Q1 pin 1 level turn HIGH->LOW.

In my case, I assembled the circuit on a small universal PCB and enclosed into TINY-2 with NB96 board.

In the case of FT-736, DL signal polarity is different from TS-790 so change as follow

3 Q2 1-----|>-----> DL signal to mic terminal
2 | Diode (1S1588 etc)

73s sueo asato JA6FTL

This modification is read 1090 times.

[top of page](#)

(TS-790) TS-790 cross band repeater mod

To operate the TS790A in the repeater cross band mode, diode D32 on the control board must be opened. In addition, two resistors must be soldered to a 13 pin din plug which will be connected to the ACC. 2 jack on the back panel of the transceiver.

To locate and open D32

1. Disconnect the power supply and antenna from the radio.
2. Remove the 14 screws that secure the top and bottom covers.
3. Carefully remove the top and bottom covers.
4. Locate the control board. this is a vertically mounehind the front panel.
5. Locate diode d32 towards the top right side of the board.
6. Using a small pair of wire cutters, cut the lead of the diode. do not pull on the lead or the diode as this may tear the foil on the other side of the board.
7. assemble the radio by reversing steps 1-3.

13 pin DIN plug configuration.

1. Using a small flat blade screwdriver, lift up on the tab of the nylon cover.
2. Once the tab clears the slot of the metal holder, pull the cover off the plug.
3. Carefully separate the two metal holders and remove the pin assembly.
4. First tin pins 1, 8 and 11 of the assembly so the resistors can easily be soldered in place.
5. SOLDER A 100K ohm, 1/4 watt resistor between pins be cut and shaped before soldering).
6. Solder a 1.5K ohm, 1/4 watt resistor between pin 8 and the lead of the 100K ohm resistor that is attached to pin 11. (the resistor leads should be cut and shaped before soldering)
7. Wrap a small piece of electrical tape around the resistors. This will insulate them from the metal holder after the plug is assembled.
8. Mount the pin assembly in the two metal holders.
9. Slide the cover over the plug until the tab engages in the slot. The "U" shaped strain relief will not be used.
10. Plug the 13 pin din plug in the ACC2 jack on the back panel of the radio.

Operating procedures

The repeater cross band operation allows the TS790A to receive on one bag signals will automatically be switched to the sub band. The TS790A will then re-transmit the signals from the main band. Each band may contain offset and sub-audible tone information (an optional TSU-5 must be installed in EACH BAND for decode).

1. Press the MAIN function swich to select the MAIN band.
2. Select the first operating frequency and mode (fm only). Select the offset as required.
3. If the CH.Q is on, press the CH.Q switch to turn the function off.
4. Select the sub-audible tone as required.
5. Transfer the contents of the MAIN band to the SUB band.
6. Select the second operating frequency anf mode (FM ONLY) and turn the CH.Q off.
7. Select the offset and sub-audible tone as required.
8. Adjustd point. The TS790A will transmit in the repeater crossband mode if the squelch controls are set too low or a signal is received.
9. Adjust the power control to allow normal output power from the MAIN band.

10. Adjust the sub band volume control to a normal listening level to monitor incoming signals.
11. To place the radio in the repeater cross-band mode, press the F. switch and then press the M.IN switch. An asterisk will light in the MAIN band display for confirmation.
12. To cancel the operation, repeat step 11 and disconnect the DIN plug.
13. If the DIN plug is left in place after use, bleedover from the SUB band audio if present will be mixed with any transmitted audio. This will make your audio during TSU-5 TONE UNIT

When the TSU-5 tone units are not installed, only the tone (encode) function can be used.
If CTCSS is to be used it must be installed in both bands to function with the cross-band repeater mode.

TX audio adjustment

The audio gain can be adjusted by variable resistor VR36 on the IF unit.
If the range of VR36 does not suffice for normal transmit audio, the values of the resistors on the 13 pin din plug can be changed. As an example, if the audio is too low, reduce the value of the 100K ohm resistor and increase the value of the 1.5K ohm resistor.

To access VR36

1. Remove the bottom cover of the radio to expose the IF unit.
2. locate VR36
3. Use a plastic alignment tool to adjust VR36 for the bottom cover.

This modification is read 1181 times.

[top of page](#)

19-07-1998

(TS-790) TS-790 with serial frequency control

by Kohjin Yamada, JR1EDE
3 Jun'90

This note is the summary of our discussion made among W9FMW, JA6FTL and myself.
The first report has been brought by WBOKSL expressing TS-790 has audio drops at the frequency change command in it's serial control.
JA6FTL confirmed the data loss at the product detector on his scope too. These are as terrible as if we use KCT Tuner in it's serial control option.

Kenwood replied to my inquiry "It is made as so to prevent the noise of PLL, about 100m sec mute is created".
Kenwood suggests the modification as below but it should be made on user's responsibility. This should be solved in their next products, I strongly told them.

JA6FTL and I confirmed that it now works perfectly on FO-20's actual test and uSATs too with the following modification.
Kenwood suggestion; (Refer to IF DIAGRAM)

You could disable the mute function by following methods, both or item 2 only.

1. Delete D20 or R191 (for SUB audio) As far as you would use the rear data port (ACC2), it's *NOT* necessary to do this, although you would still have the audio drop at the sound of loud speaker. Of course, you should do this modification when you would hook up the audio data from Microphone Plug.
2. Put a jumper between Q4 collector and emitter (for SUB RF Block) This modification is a *MUST*.
You can do this by several ways but the above is most easy.

The following discussion might help you a bit;
(partly edited by me)

I wrote to W9FMW;

>Cut the line between Q4 Collector and R15 (470 ohm) and Ground the end of
>R15. JA6FTL made the mod removing Q4 entirely and grounding the end of R15.
>Q4 located the left of Q5, they are located roughly opposite side of L2, L3.
>JA6FTL says the modification needs a magnifying glass, Hi.

There is 1 Reply.

Here is additional info. to the modification.

Yes..... Need magnifying glass (I am not farsighted nor shortsighted Hi.) This modification is to disable the blocking line for IF amp. Audio muting function remains unchanged, but it is no problem to use rear data port. (Audio muting circuit consists of D20 and Q12)

1. Put the frontside toward you and remove the bottom cover of 790.
2. Remove the 13 screws that fix IF board. Lift over up the board toward you.
3. Q5 and Q4 are located just opposite side of L2 and L3.
Chip Q5 (printed "V11") has 4 solder legs, and it's located next to R15 (470 ohm surface mount resistor, printed as "471").
Q4 is located just beside R15 and has 3 legs.

This modification is read 1153 times.

[top of page](#)

19-07-1998

(TS-790) TS790E - Burned out diode

Hi to all fellow TS-790E owners,

Just a quick note to warn users of this magnificent wireless of the dangers of exceeding the recommended duty-cycle on full power transmit on 430MHz.

My 790 puts out about 45 watts of RF on UHF (slightly more than the quoted spec). The other night whilst listing messages from the BBS, I suddenly lost RF output from the UHF section. The radio was also drawing excessive current when the TX was keyed (22 Amps @ 13.8V - normally 16 Amps @ full output power).

I returned it the following day to the dealer where I bought it 22 months ago and they diagnosed a burnt out RX/TX switching diode (D2 in the circuit diagram). It was not only burnt out, it had disappeared! It is a special component and cost about 15 - total repair cost 50.

One week later I got it back and all was well again with no other damage apparent. I do not think the failure was caused by using packet as the duty-cycle at the time was very low indeed (just listing the new messages for the day). I think it all started the night before when I had an hour long QSO using full power FM on 433.550. The radio gets pretty hot under these conditions and its internal cooling fan was running continuously after about 5 mins on air. The manual does warn the user to allow the transmitter to cool after extended transmitting, but is not specific about the duty-cycle when using full power.

So, please be careful with your 790 and don't cook it like I did. It is NOT CAPABLE OF A 100% DUTY CYCLE when using maximum power on UHF. It does not get as hot when using VHF but caution should be exercised if the fan is running continuously. I would not expect there to be any problems when using SSB on either band, nor would I expect normal packet/data use to cause problems.

YOU HAVE BEEN WARNED !
73's from Paul, G7PNR @ GB7DBY.

This modification is read 1152 times.

[top of page](#)

11-08-2000

(TS-790) 800MHz Recieve Mod for Kenwood TS-790

Author: Schreiter Keith - keith.schreiter@sbt.siemens.com.MODIFICATION.NET

Cut D29 on the control unit.

Install a BNC connector on the rear panel where the black plastic plug is.

Run a piece of 50 ohm coax from the BNC to TP201/202 on the RF unit. TP 201 is the center and 202 is the shield. That is the 800 MHz rx antenna.

Date: 08-11-2001

User comment

From: [Hans, PA3HGT](#)

Subject: Photos

Thanks to PA3HGT for the photos.

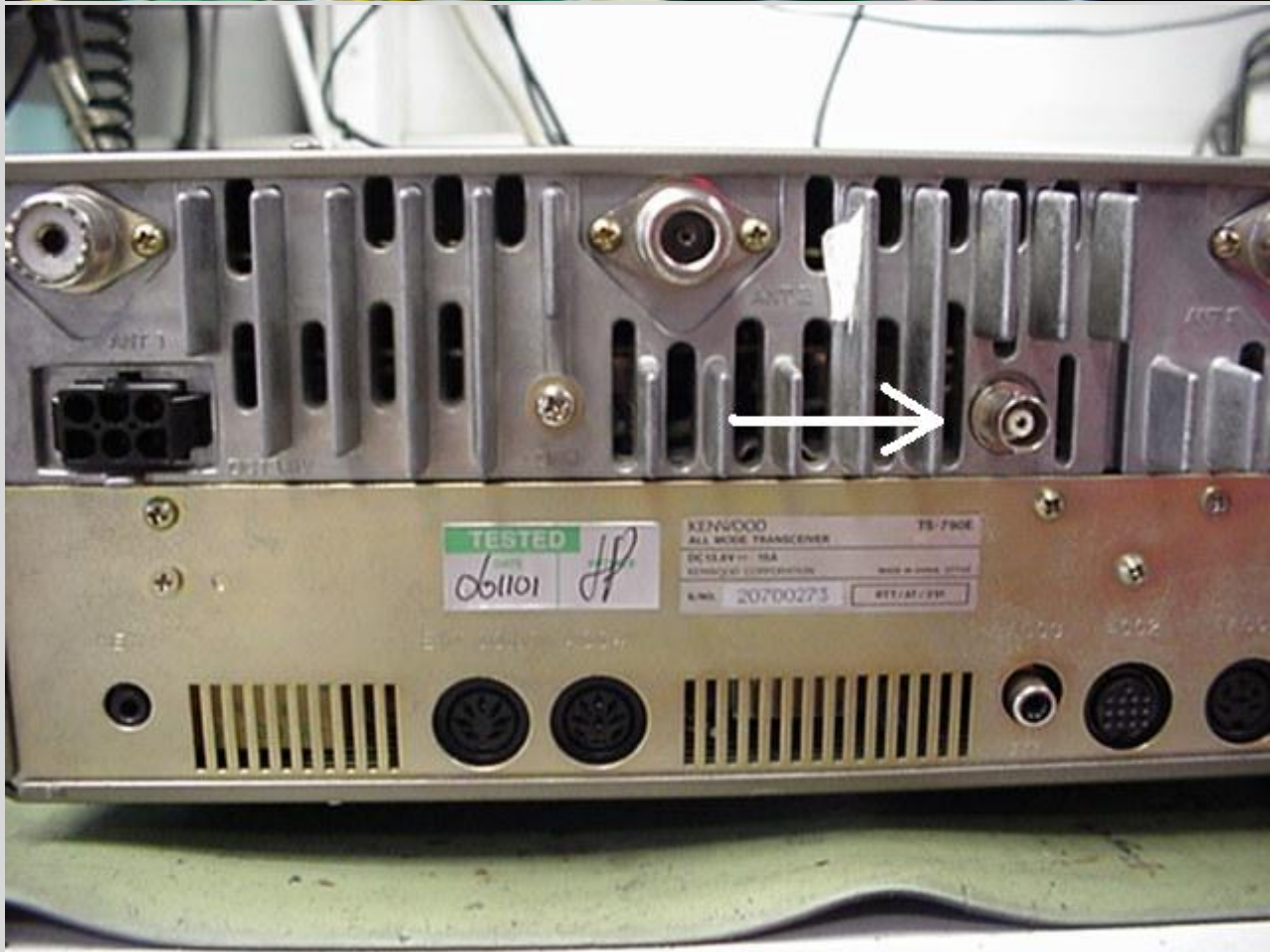
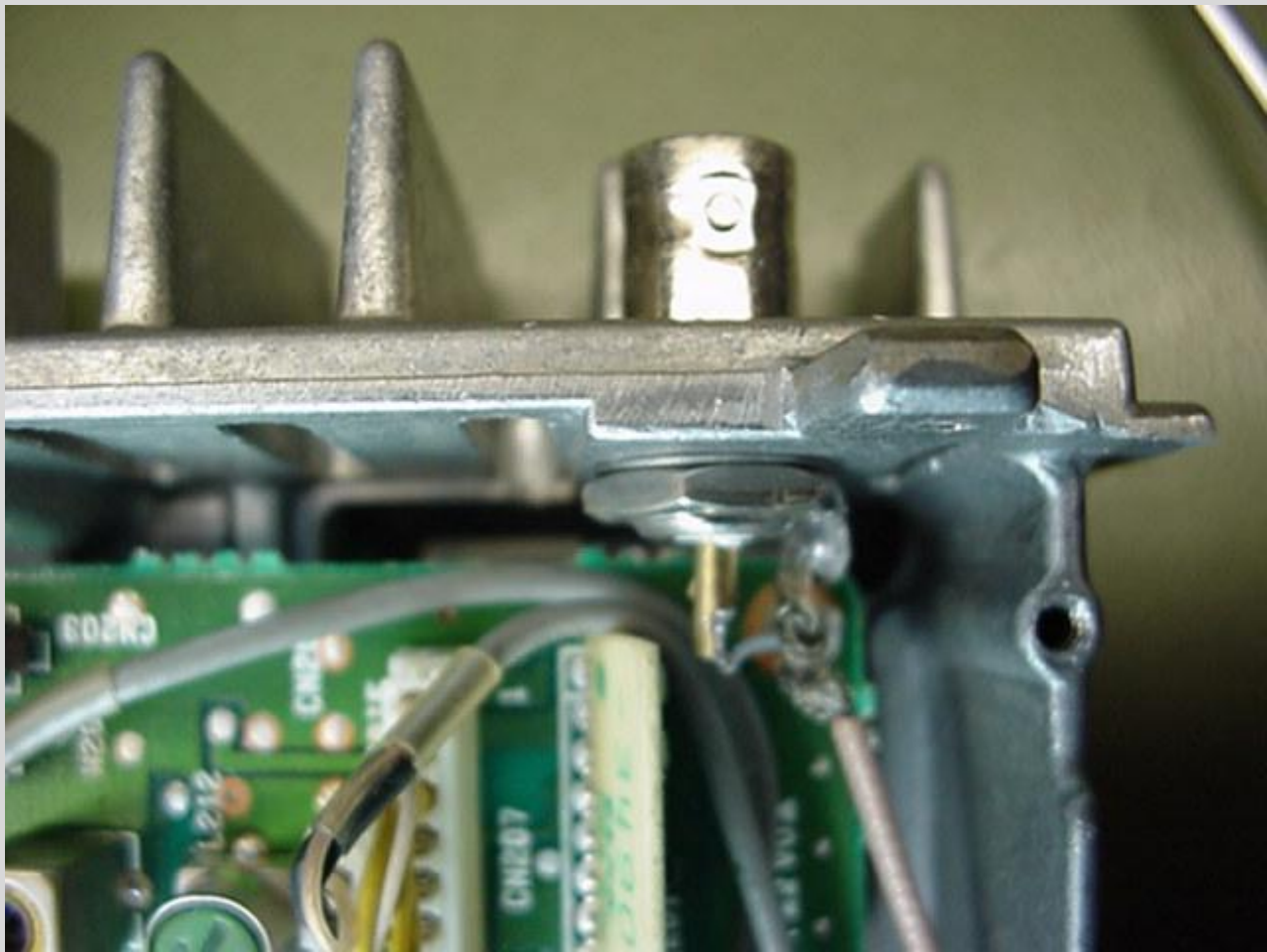



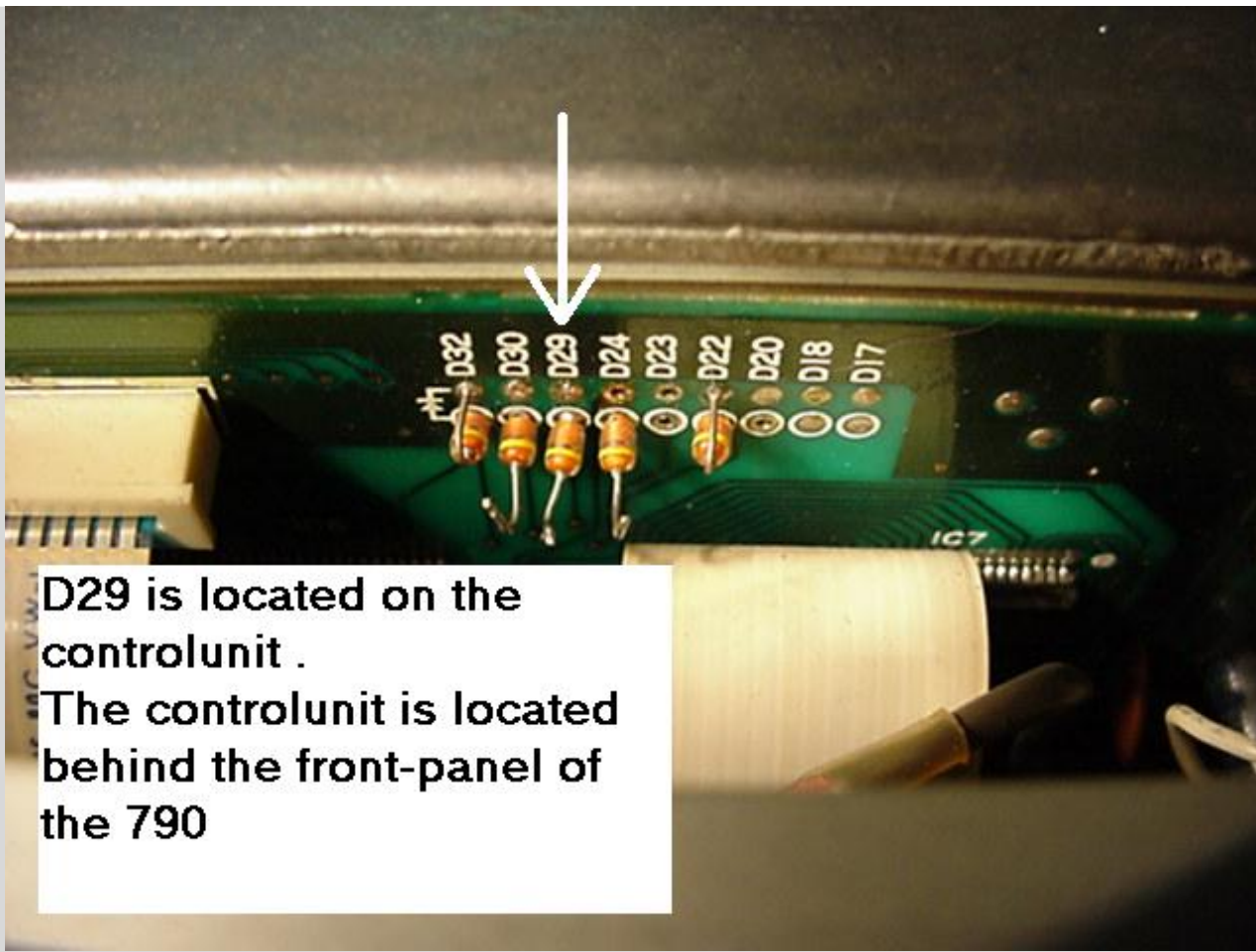

This modification is read 1257 times.

[top of page](#)

01-02-2001

(TS-790) TS-790 SSB Power Increase

Author: Greg - kj6ko@innercite.com. MODIFICATION.NET

If you look at the specs on your new TS-790, you will notice that the SSB power output is about 10W lower than FM or CW.

This is an easy fix.

On the IF board, on the bottom of the radio, near the MIC/RF POWER knobs, there is a small jumper/diode labeled "SSB PWR DOWN". It is cut from the factory. Reconnect it.

On the schematic, it is shown as a jumper but it looks like a diode. There was enough metal left on the leads on mine to reconnect it.

The PEP power will now be the same as FM/CW. The PA for both 432 and 2m on this radio are rated at 60W so it shouldn't be a problem.

I havn't tried to raise the power up to 50W yet as my Commander likes about 45W+ if it is carefully tuned for around 1100W+ out. With these PA's, 50W should be quite safe on both bands.

This mod should have no affect on 1296 as it is rated the same on SSB and FM. I will do a two tone test just to make sure it is still clean.

Date: 16-05-2001

User comment

From: Hans PA3HGT

Subject: Pictures

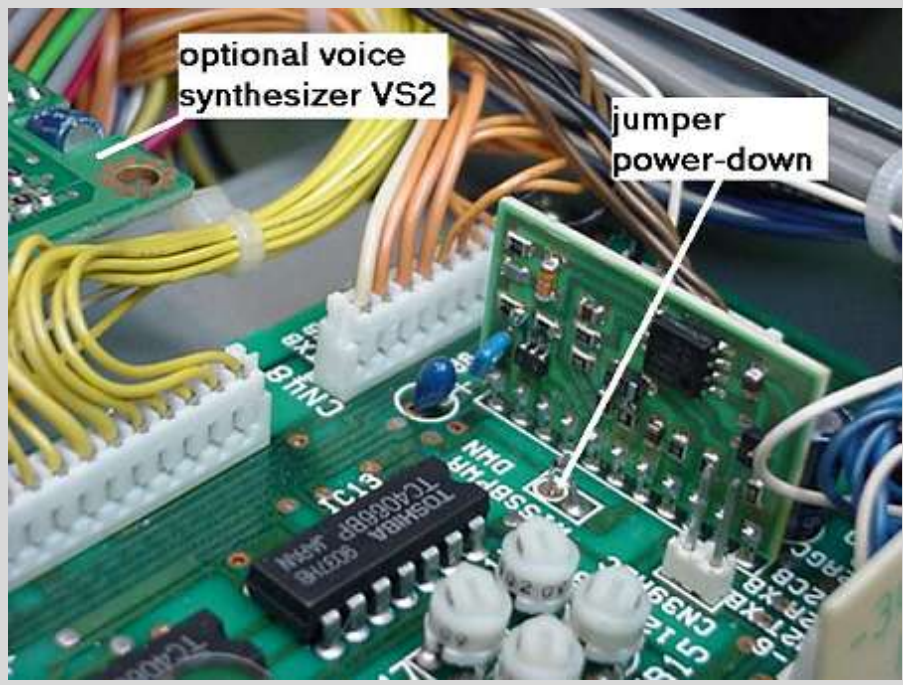
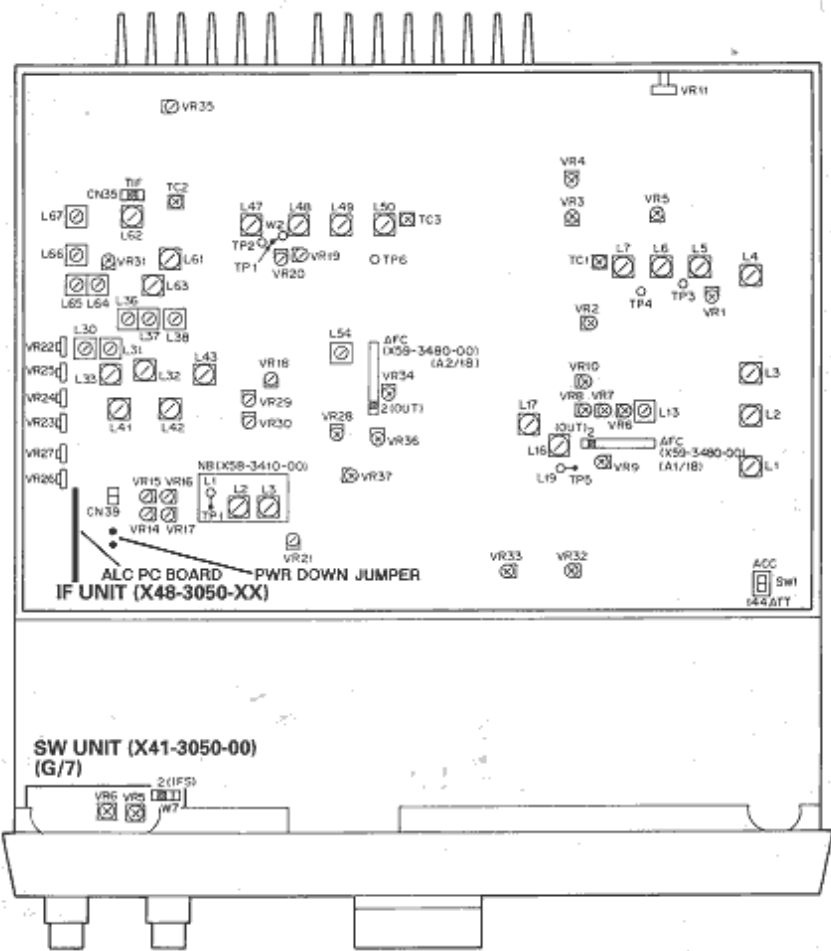

This modification is read 1316 times.

[top of page](#)

22-09-2001

(TS-790) TS-790 A/E 9600bd via ACC4 port RX-problem

Author: Hans PA3HGT

A few owners of a Kenwood TS790A/E have some complains to receive weak packetsignals at 9600baud speed with a packetradiocontroller of Symek , model TNC2H-DK9SJ . if you operate 9600 bd packet with the ACC4 port , check this:

- If you connect the tnc (packetradiocontroller of Symek , model TNC2H-DK9SJ) with the ACC 4 port , you can hear a slightly different sound then when the tnc isn't connect to the ACC 4 port of your TS790 A/E.
- Signals with a strenght 3 and above are no problem but below strenght 3 is diffucult to work with 9k6 packet.

The problily cause is that the input of the amplifier in the TNC has an too low impedance for the Kenwood TS790 A/E (if-osc section) .

The simple solution is to solder a 100 K 1/4 wt resistor in the RX-audioline between the TS790 A/E acc 4 port (pin 3) and the 5 pol din of the TNC from Symek (pin 4) .

I started with 10 K and ended with 100 K for the best result.

You hear no different sound when connect or remove the cable Symek TNC2H/Kenwood TS790A/E after the change .

No re-adjustments needed .

73,
Hans,PA3HGT

This modification is read 1077 times.

[top of page](#)

01-11-2001

(TS-790) Kenwood TS790 ALC-modification

Author: Kenwood and Hans, PA3HGT

Extracts from KENWOOD Service Technical Report No. E51-89-002 date FEB 10 1989

The talk power of the TS-790 is lower than previous models i.e. TR-851 and TS-811.

Not all versions of the RIG suffer from this problem. I have the TS-790A and the following modification was done when I purchased the RIG.

The report was sent to the following TRIO-KENWOOD offices.

T-K CANADA
T-K AUSTRALIA
T-K NV,SA

The following is quoted from the Service Report.

To boost the talk power of the TS-790 to almost the same level of the former models surpress the ALC response like the former models.

Connect a 0.039 to 0.047 uF between pins 6 and GND of IC201 on the ALC amplifier daughter unit (X59-3480-00 (F)).

NOTE: This above alteration distorts the SSB transmission signal quality. Thus the alteration will not be applied to mass production.

End of quote.

The mode was done on my RIG from the factory and I have had no reports of poor audio!!

The following white noise check is shown in the Service Report.

	ORIGINAL	ALTERED
Low ALC level	1 to 1.5 W	2.5 to 3.0 W

NOTE PA3HGT:

You can find the ALC unit on the IF pc-board . The IF pc-board is located below the Kenwood TS790 . So you have to remove the bottomcover.

You can see on the picture of the IF pc board how to locate the ALC pc-board X59-3480-00. The picture with the ALC board shows how to solder the capacitor.

Be careful to solder with not too high temperature because you can damage SMD components. You can choose to solder de capacitor between R201 or D201 and GND if you don't like to solder on pin 6 of IC201. (see picture ALC pc-board) Work if possible ESD (Electro Static Discharge) safe !

Succes , I take no responsebility if things go wrong !

73 , Hans , PA3HGT

Pictures are taken from the servicedoc ts790 of Kenwood.

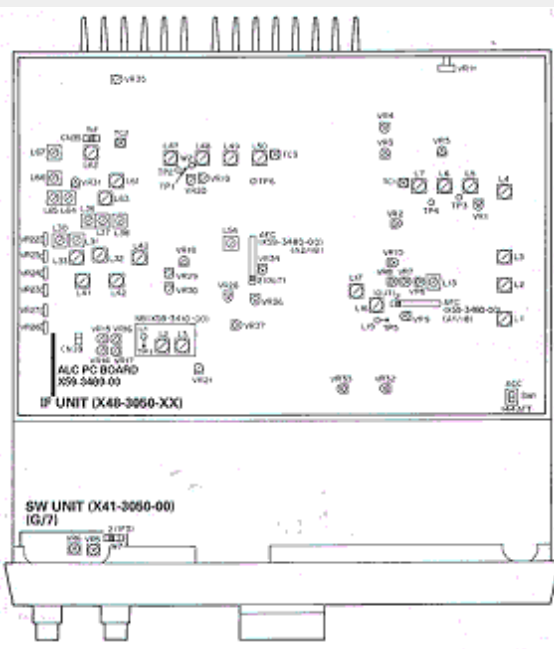

ALC (X59-3480-00 (F)) Foil side view

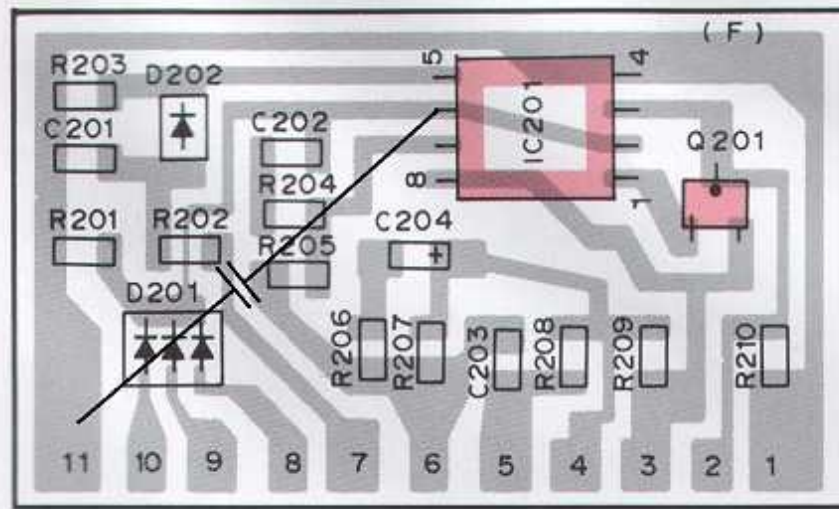

This modification is read 1066 times.

[top of page](#)

09-11-2001

(TS-790) Convert TS790E to the USA TS790K and RX/TX mod

Author: PE3HMP - PE3HMP@hotmail.com. MODIFICATION.NET

My idea was to disable the 1750Hz feature on the TS790E and enable the sub tone encoder.

Kenwood USA was not willing to help (because I'm outside the usa) and Kenwood Belgium says it can not be done.

Before You even open the transceiver try to work ESD (anti static) safe, use a wristband connected to a 'clean' earth make sure Your soldering iron is connected to the same 'clean' earth.

EVERYTHING YOU DO IS AT YOUR OWN RISK !!

After looking at the diode chart of the control unit I saw that one diode is only used in the E (European) version, so I thought it would be easy to convert it, the biggest trouble was to find the D21 diode I was on the back of the control unit, after removing the diode it was possible to switch sub tones on and off BUT there was no way I could set the freq of the sub tones (the micro processor still saw the TS790 as an E version).

So there is no way to get that working properly unless You change it to the K version (I don't know if the J, M, M2, W2, W3 have the sub tone feature).

In the Netherlands You may have a transceiver that works outside the ham bands so converting is no problem.

here is what I found out that some of the diodes do (if someone has more info I would like to know it)

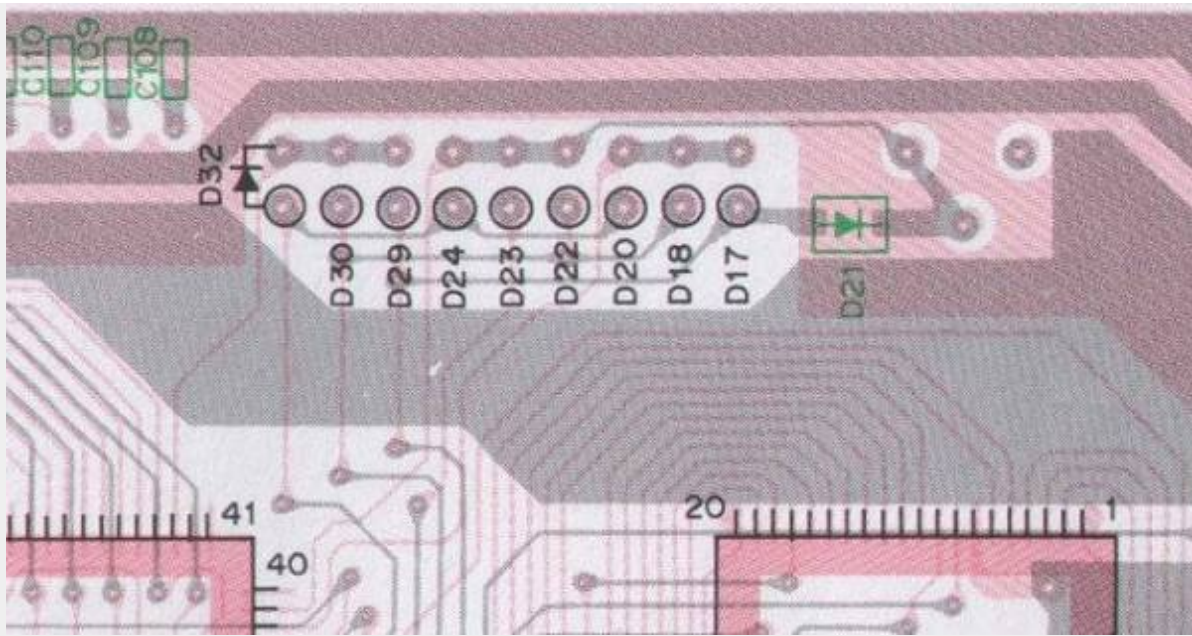

Well to change the European version to the K version you have to cut the following diodes (do it so that it is possible to reconnect them, You never know if you want to return it to it's original state)

Cut D21, You have to remove the entire control unit because its on the back of the control unit (be careful with the flat cables and remove the iron clip that is holding the left ic on its place) (I cut the copper line on the cathode side of d21)

Cut D30,29,24,23,21 (I have cut them about 5 mm away from the glass)

Now place a 1N4148 into the D22 place (You do not have to stick it all thru just make sure it makes good contact) it has the same polarity as the other (previously cut) diodes

If You want wide RX cut D29

If You want wide TX cut D30

Well putt everything back together, the only thing I had to change are the freq steps (to 12.5KHz) and the repeater shift (0.6 and 1.6KHz)

Now I can work repeaters with a sub tone Like Rotterdam and Antwerp.

I like to thank PA3HGT and PA3DSC for giving me the schematics (because my service manual was held up in the mail)

Well all the pictures should make things very easy for You, If there are any problems or suggestions pse e-mail me:

PE3HMP@hotmail.com

Thanks to [PE3HMP](#) for the modification and pictures.

This modification is read 1141 times.

[top of page](#)

18-11-2001

(TS-790) TS790 SSB Power Up

Author: Mark PE3HMP - PE3HMP@Hotmail.com.MODIFICATION.NET

You may have noticed that the SSB power of Your Kenwood TS790 is about 10 Watt less than the FM power.

The reason for this is unknown to me especialy because a transceiver gets less hot in SSB mode.

There is a simpel mod to get the same outputt power on SSB (45 Watt)

Trie to work ESD (anti static safe) and if something goes wrong don't blame me ;-)

Near the ALC board is a jumper that looks like a diode but in fact is just a 0 ohm resistor, You can find the alc board when you remove the outside covers and putt the transceiver upside down, look left/front, You will find the SSB power down as shown in the picture.

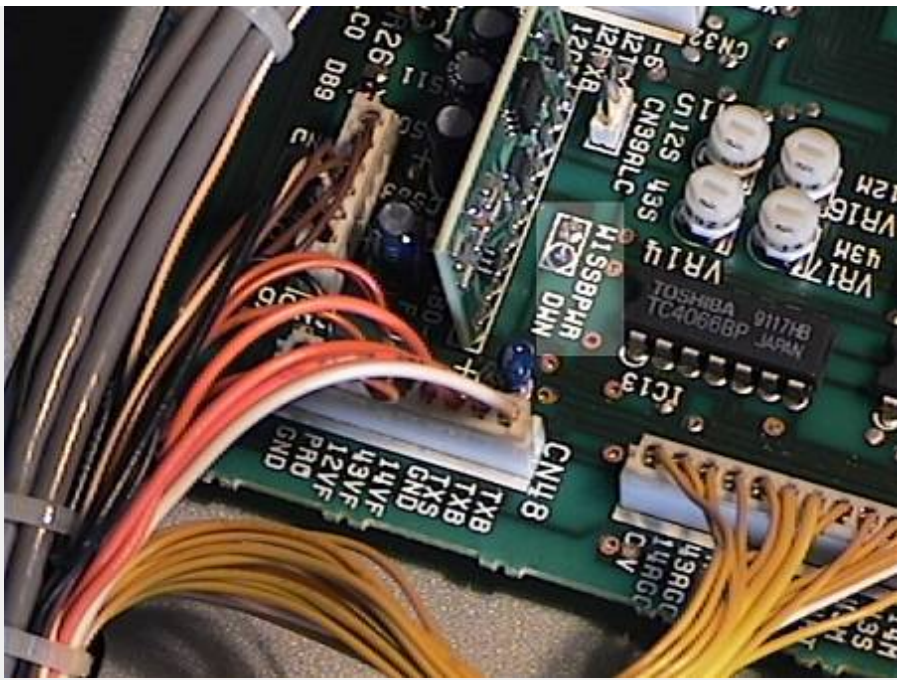

Just reconnect it and You will have 10 Watt more PEP power on SSB

Suggestions, comments, ideas just mail me PE3HMP@Hotmail.com

Thanks to [PE3HMP](#) for the modification and picture.

This modification is read 1149 times.

[top of page](#)

19-07-1998

(TS-811) 9K6 baud modifications for KENWOOD TS-711 & TS-811

The following modifications, while not guaranteed certainly work on my radios:

I do not use the ACC 1 Connector on the back panel so I have removed the plastic plug and mounted a five pin DIN socket, although you can use any socket that fits.

The requirement for the 9600 baud modem is that transmit audio must modulate the varactor directly, and receive audio must come directly from the discriminator output, both these points are fairly easily accessible;

USE GOOD QUALITY AUDIO SCREENED CABLE FOR CONNECTIONS

1. Remove top and bottom covers of TS 711/811.
2. Turn set upside down and locate the PCB marked IF Unit X 48-1400-01 it is the large one on the left facing the rear of the set.

Mark, z11tre

RECEIVE AUDIO

1. Locate R 173 (3.3K), at the rear left side of the IF Unit PCB alongside a 1 ufd electrolytic capacitor (C 163). The connection to the discriminator output should be made at the junction of R 173, C 159, R 199 and C 163. I did this with a very fine tip soldering iron by soldering to the lead of R 173 nearest to C 163 although it could be soldered under the board if your iron is not small enough. The earth screen I soldered to a lug under the screw head located close by at the corner of the board.
2. Run the cable to the socket on the rear panel and wire as desired.

TRANSMIT AUDIO

1. On the same PCB at the front right (facing rear) locate R 11, mounted upright alongside J2 (4 way socket). Connection to the Varactor can be made at Pin 2 of J2 or as I did by carefully filing the lead of R 11 and soldering to it directly. The earth shield I soldered to a lug under the PCB corner mounting screw.
This earth is also available at J2 Pin 1.
2. Run the cable to the socket on the rear panel and wire as desired.
3. If you have a scope available, set the tx level to 1.5v P to P at position FMM. If no scope, set the tx level pot on the G3RUH modem to the 11 o'clock position and experiment.

UoSAT 3 only requires TX Audio from the 711 and RX Audio from the 811 but I would recommend wiring both in each set for future satellites such as RUDAK etc. You will also need to provide a Push to talk connection to your TNC either from the ACC 2 connector or mic socket. I wired from the back of the ACC 2 connector to the DIN socket that I mounted in the spare hole.

Good luck, ZL1TRE, Auckland, New Zealand.

31-03-1999**(TS-811) Betr.: 9600 Bd G3RUH-Modem an TS 711/811***de DC5KC @ DB0IZ*

Liebe OM's.

Der Anschluss eines 9600 Bd Modems nach G3RUH an einen TS 711 bzw. TS 811 kann bekanntlich nicht ueber den dafuer vorgesehenen ACC2 jack erfolgen. Das TX AUDIO - Signal muss direkt an den FM - Modulator gelangen.
Das RX AUDIO - Signal muss direkt am FM - Demodulator abgenommen werden.

Modulator. (TS 711/811)

Das TX AUDIO - Signal wird ueber ein abgeschirmtes Kabel und ueber einen 6,8 kOhm Widerstand an den Anschluss FMM gelegt. Der Widerstand liegt zwischen Kabelseele und Anschluss FMM. Der Anschluss FMM ist zu finden auf:
AF - UNIT, Stecker 4, Pin 3. (GND = Stecker 4, Pin 2.) oder
IF - UNIT, Stecker 2, Pin 2. (GND = Stecker 2, Pin 1.)

Demodulator. (TS 711/811)

Das RX AUDIO - Signal wird ueber ein abgeschirmtes Kabel am FM - Demodulator abgenommen. In der unmittelbaren Naehe des Steckers 9 auf der IF - UNIT befindet sich der Widerstand R 173 (3,3 kOhm).
Dort wo der Widerstand R 173 mit den Kondensatoren C 159, C 163 und dem Widerstand R 199 verbunden ist, wird die Kabelseele angeschlossen und mit dem RX AUDIO Eingang des Modems verbunden.

Abgleich.

Am Anschluss FMM sollen 1500 mVss sein oder alternativ vor dem 6,8 kOhm Widerstand entsprechend ca. 3200 mVss.
Diese Werte werden mit dem Potentiometer VR1 auf dem 9600 Bd MODEM eingestellt.

Der Einfachheit halber habe ich diese Aenderungen (MOD. und DEMOD.) gleich an beiden Geraeten ausgefuehrt.
Die genannten UNITS befinden sich auf der Unterseite des Geraetes und die entsprechenden Anschlusspunkte sind gut zugaenglich.
Auf dem ACC2 jack habe ich fuer die Verbindung zum Modulator (FMM) den freien Pin 10 genommen. Fuer die Verbindung vom Demodulator nahm ich Pin 5.

Viel Spass beim Loeten und bei den QSO's mit dem G3RUH 9600 Bd MODEM.

73 und 55 de HB9MGI @ HB9AC.

31-03-1999**(TS-811) 16kHz-Filter für TS-811E (9600bd-paketierer)***de DL8NL @ DBOCL. #HB.DEU.EU*

Hallo 9600db-Paketierer,

nach Umbau meines TS811E nach diversen Vorschlägen blieb noch das Problem mit dem schmalen Filter. Nach langem Suchen nach geeigneten Keramikfiltern bin ich nun fündig geworden und habe heute, am 23.4.94 meine ersten 9600bd Verbindungen gehabt. Leider kann ich nur ein Relais mit 9k6 empfangen, und dazu noch sehr schwach (S1-S2). Aber es klappt ganz prima ohne Unterbrechung und mit guten Übertragungsraten. Ausrüstung: TS811E+ TNC3S+ GP V1.61 So, nun das Filter: CFK455E von Murata (zu bekommen bei Fa. Helpert).

Es ist das Spitzenfilter von Murata und paßt oh Wunder direkt auf die Platine in schon gebohrte Löcher! Weniger sollte man sich nicht gönnen,hi.

Bei 16kHz Bandbreite sollte es nun keine Empfangsprobleme geben.
Mit den Umschaltzeiten kann ich bis auf 50 msec heruntergehen beim Connecten.
Danach regelt die TNC3-Software (TNC3BOX V.1.10) alles weitere.

Hoffentlich stellen nun bald noch mehr Relais auf 9k6 um, damit das Pakete-versenden und -empfangen noch mehr Spaß macht.

73 mit schnellen Bits de Diethard, DL8NL @ DB0SHG

19-07-1998

(TS-820) TS-820 Fix the problem with the display

Here is something you can do if your digital display on the kenwood ts-820 is giving you a problem.....

1. Remove the counter assembly unit from the 820.
2. Remove both circuit boards from the counter assembly (upper and lower boards).
3. Scrape away the varnish from the corners of the boards where the interconnecting screws and spacers hold the boards into the case.
4. Reassemble the counter....

That should take care of the problem..

This modification is read 1116 times.

[top of page](#)

19-07-1998

(TS-820) New Display Tube for DG-1

The original display tube (LD-8109) used in the DG-1 digital display for the TS-820 and TS-820S has been discontinued by the manufacturer. However, there is a replacement tube available. This tube is the LD-8135. It is not a direct replacement for the original tube. The leads come out of both ends of the display tube instead of just one as in the LD-8109. Therefore, it will be necessary to replace the complete display unit if the display tube fails. The part number of the new display unit is X54-1310-00. Please use this part number when ordering a replacement display unit. The new display unit is being installed in the current production of the TS-820S and DG-1.

The new display unit (X54-1310-00) is a little more involved to install than the old one. The installation is as follows:

1. Remove the top cover of the TS-820 (or TS-820S) and set the unit on the bench so the front panel is facing you.
2. Remove the two screws from the original display unit (save them), unplug the display unit from the counter assembly and remove the display unit from the transceiver.
3. Run the connector of the new display unit through the left bracket (from the center).
4. Gently (but firmly) push the right side of the display unit through the right bracket. (This is the most difficult part).
5. Gently push the left side of the display through the left bracket.
6. Install the screws from the old display in the mounting bracket of the new display unit and plug the connector into the counter assembly.
7. Turn on the TS-820 (or TS-820S) and make sure the display tube works properly.
8. Replace the top cover of the transceiver.

This modification is read 931 times.

[top of page](#)

19-07-1998

(TS-820) TS-520, TS-820 CW filter select control

Author: Trio-Kenwood Communication, inc.

Service Bulletin no. 812 (14-2-1980)

In the TS-520SE, the Heater Switch has been replaced with a CW WIDE/NARROW select switch. For those operators who desire this type feature for their transceiver, the following information may be considered as a guideline.

TS-520S series transceivers

1. A miniature SPDT switch may be installed at the operators preference, on the rear side, or bottom panel. Use this to switch the CW or SSB filters by wiring the BROWN lead, which normally is transferred to the CW terminal on the IF unit, between the SSB filter, for WIDE , and CW for NARROW.
2. A Traditional solution has been to use the FIX CH switch, position 3 and 4 for filter switching. This may be done by completely rewiring the switch, or by leaving the switch wiring and the filter wiring as for normal operation, and bridging the following terminals:

- A. FIX CH C terminal to IF SSB Terminal
 - B. FIX CH 4 terminal to IF CW terminal
- Placing the FIX CH switch to 4 will operate the SSB filter in CW mode.

TS-820S Series Transceivers

1. Similar to the TS-520 series, a miniature SPDT toggle switch may be installed at the operators preference a the rear or on the obttom cover.
2. The FIX CH switch, or Digital Hold switch may be rewired to control the CW wide/narrow function

On the MODE switch, S6-1, the SSB filter control is GREEN, and the CW filter control line is GREY. Break the GREY line and connect it from the MODE switch to the SPDT common terminal. Connect the GREY line to the IF unit ot one terminal, and bridge tht GREEN SSB line to the other Switch terminal.

This modification is read 879 times.

[top of page](#)

19-07-1998

(TS-820) Installing AUX Band in TS-820 (RX only)

Author: *Trio-Kenwood Communication, inc.*

Service bulletin no. 11 13-1-1977

The following information is for the installation and alignment of the AUX band inthe TS-820. This extra band will be for receive only. Reference will be made to schematics and board layouts as shown in the Service Manual.

Installation

1. Remove the top and bottom covers.
2. Remove the Connectors from the PLL Assembly.
3. Remove the PLL assembly and set it aside.
4. Use the board layout of the Coil Pack to locate thepositions for the ANT and MIX coils on the Coil Pack.
5. Install the ANT and MIX coils on the Coil Pack.
6. Remove both covers from the PLL Assembly.
7. Remove the 5 Phillips head screws holding the PD Unit in the PLL assembly and carefully remove the PD unit.
8. Use the board layout of the PD unit to locate Q11.
9. Install R01, R02, C01, C02 and X01 as needed for the band desired.
10. Locate terminals AUX, B1, B2, B3, and B4 on the PD unit.
11. Install a jumper from the AUX terminal to the B terminal for the band desired. B1 is for 1.8 MHz to 9 MHz, B2 is for 10MHz to 18MHz, B3 is for 19MHz to 24MHz and B4 is for 25MHz to 30MHz.
12. Replace the PD unit in the PLL Assembly.
13. Use a 3mm nutdriver to remove the 4 hex nuts mounting the VCO unit in the PLL assembly, then remove the two phillips screws.
14. Carefully remove the VCO unit from the PLL assembly.
15. Use the board layout of the VCO unit to locate Q11.
16. Install C01, C02, C03, C04, C05, and T11 as needed for the band desired. Install T11 last.
17. Replace the VCO unit in the PLL assembly.
18. Install the connectors on the PLL assembly.

Alignment

1. Turn on the TS-820.
2. Tune VFO to 250.
3. Set band switch to AUX.
4. Set the TUN/NOR switch on the VCO unit to TUN.
5. Connect a frequency counter to terminals TP5 and TP6 on the VCO unit. (TP6 is ground).

6. Adjust T11 for a frequency of 9.08 MHz plus the lower limit of the band desired.
7. Connect a frequency counter to TP4 and ground on the PD unit, and verify the frequency of the reference oscillator. It may vary +/- 500KHz.
8. Return the TUN/NOR switch on the VCO Unit to the NOR position.
9. Turn off the TS-820S.
10. Replace the covers on the PLL assembly and reinstall it in the transceiver.
11. Replace the top and bottom covers on the TS-820S.

COIL PACK

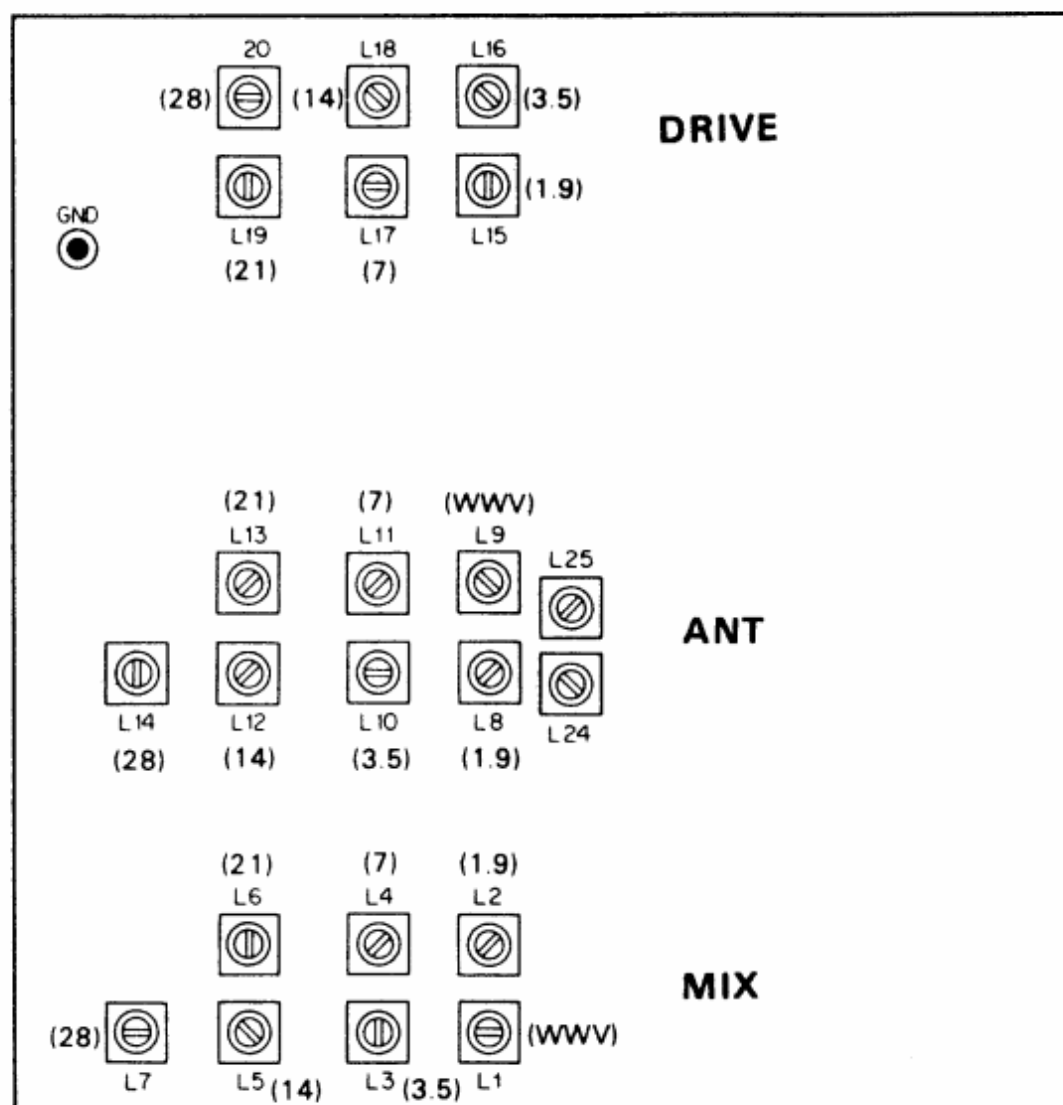

Fig. 23 Coil pack unit

Adjusting sequence	BAND	VFO scale
1	1.8	100
2	3.5	250
3	7	150
4	14	175
5	WWV	0 (15.0MHz)
6	21	225
7	28.5	500

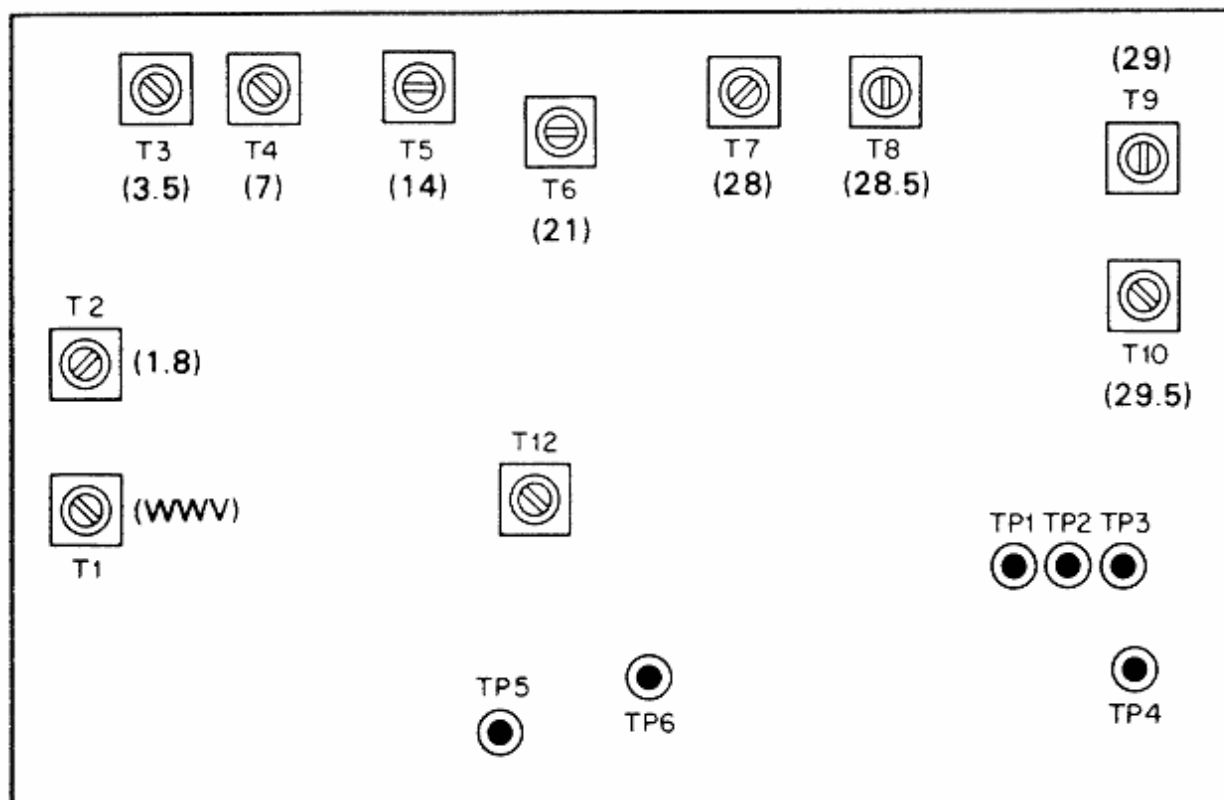

Fig. 22 VCO unit

Thanks to [Eric Bourlet](#) for the two drawings.

Caution Do not use magnetized tools when working on the PLL assembly. Beryllium tools would be better than ferrous ones. If the PLL assembly should become magnetized, use a bulk tape eraser on open core AC transformer to demagnetize it.

This modification is read 977 times.

[top of page](#)

19-07-1998

(TS-820) TA7201P Substitution Parts Kit

Author: Trio-Kenwood Communication, inc.

Service Bulletin no. 954 (20-7-1989)

The Toshiba TA7201P audio amplifier (Q3) used in the TS-820(S) and R-820 is no longer available. The part has been replaced with a kit (Part # W05-0257-00). This service bulletin will provide the correct installation procedures for replacing a defective TA7201P with the new kit.

1. Disconnect the power cord and antenna from the transceiver.
2. Remove the covers from the transceiver and disconnect the speaker wire.
3. Remove the AF AVR board from the bottom of the transceiver (4 screws and 3 connectors).
4. Remove the two nuts that secure the heat sink to the audio amplifier (Q3) and then remove the heat sink. Figure 1.
5. Desolder and remove Q3, C21, C22, C26, C33, R40, R42, and R47 from the AF AVR board. C33 and R47 are mounted on the foil side of the board, but may not be installed on some models. Figure 1 and 2.
6. Using the parts from the kit, install a 22 uF capacitor in the C21 position, a 0.068 uF capacitor (labeled 683K) in the C22 position, a 3.9 ohm resistor in the R40 position, and a 470 ohm resistor in the R42 position. Figure 1
7. Solder a 0.1 uF capacitor (labeled 104K) in parallel with C30. Mount the part on the foils side of the AF AVR board. Figure 1
8. Remove the two nuts from the heat sink mounting screws. Figure 3.
9. Replace the mounting screws with the ones in the kit. If the original screws have been soldered to the board, remove the excess solder and while the screws are still hot, turn the board upside down to allow the screws to fall onto the workingsurface. Figure 3.
10. Secure the new mounting screws with the two nuts that were removed in step 8. Figure 3
11. Install the heat sink and secure it with the two hexagon bosses from the kit. Figure 3

12. Insert the wires from the new audio amplifier circuit board as shown in the diagram. Make sure the pins are firmly seated and then solder them into place. Figure 4
13. Apply a thin layer of silicon grease to the back of the audio chip.
14. Insert the circuit board into the heat sink and secure it with the two nuts that were removed in step 4. Avoid pinching the wires between the board and the bosses as well as the board and the heat sink.
15. Attach the heat sink spring from the kit over the chip. Figure 5
16. Assemble the transceiver by reversing steps 1-3.

Note:

Due to the differences in characteristics between the TA7201P and the new audio chip, the noise level will be increased. The increase in noise will effect the position of the AF gain control. Should it be found that the audio is too low, the value of resistor R4 on the AF AVR board can be reduced from 220 ohms to 82 ohms. The resistor removed from the R40 position can be used in this situation.

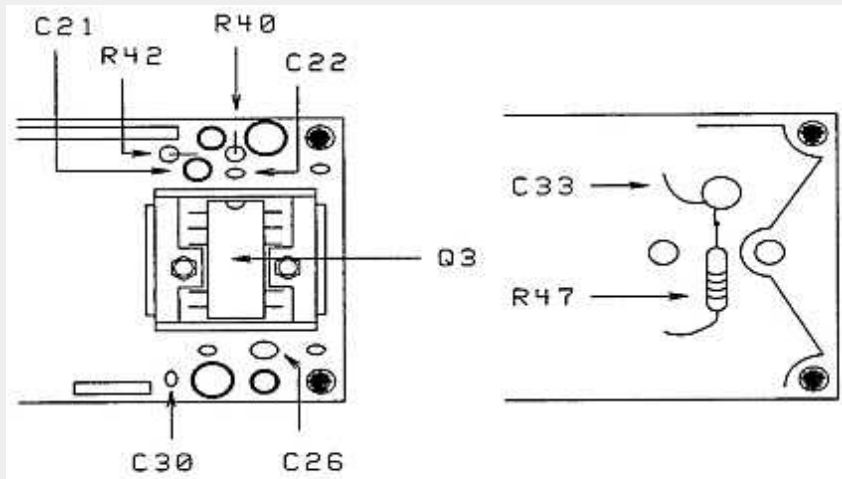

FIGURE 1

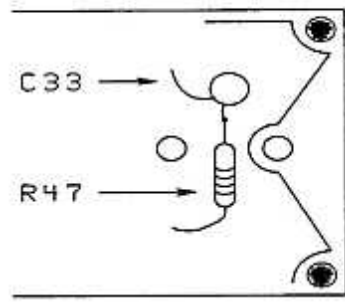

FIGURE 2

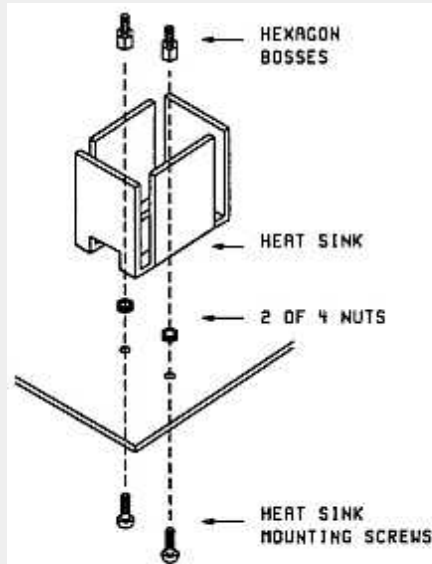

FIGURE 3

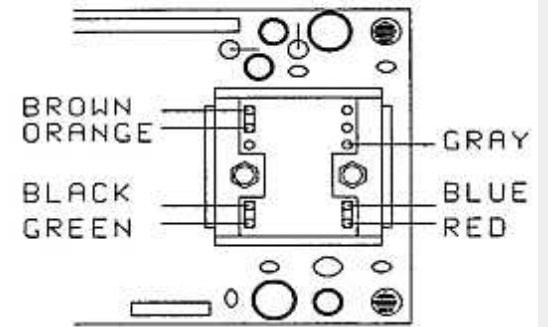

FIGURE 4

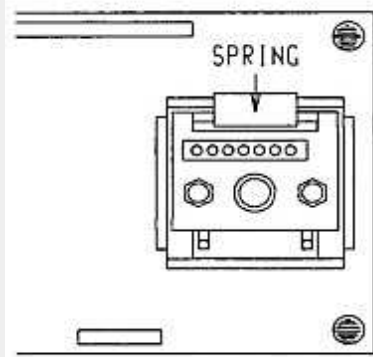

FIGURE 5

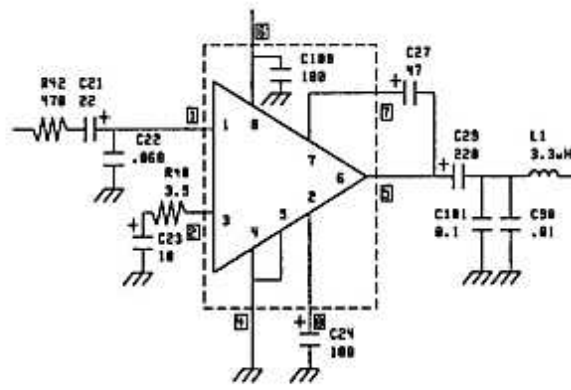

FIGURE 6

This modification is read 853 times.

[top of page](#)

19-07-1998

(TS-820) TS-820 Speech Processor Alignment

Author: Trio-Kenwood Communication, inc.

Service bulletin no. 9 17-11-1976

The following alignment procedure may be used in lieu of the one in the Service Manual.

Test Equipment required:

- Audio Signal Generator
- Audio VTVM
- Oscilloscope or RF VTVM

1. Preliminary control settings:
 Screen grid switch off.
 Mode switch to USB.
 Comp Level to USB.
 Processor SW to Pull "ON".
 Meter switch of "Comp".

Send/Rec switch to "Send" as required when making adjustments.

2. Apply 1500 Hz audio signal to the mic jack at 10mv level.
Connect RF VTVM or scope to TP-2.
Adjust T-11, 12, 13, for maximum level on the S-meter.
Adjust T-14 for maximum level on scope or VTVM at TP-2.
3. Turn compression level to min, (CCW).
Reduce audio sig at mic jack to 0.3 mv.
Adjust TC-4 (Freq response for speech processor) so that level at TP-2 is not changed when changing audio gen from 400 Hz to 2000Hz.
4. Turn compression level to max, (CW)
Set audio gen to 1500Hz at 0.3 mv.
Adjust TC-3 and VR-6 (carrier bal for speech proc) for maximum level at TP-2.
5. Set audio gen to 10 mv at 1500Hz
Send/Rec switch to send
Adjust VR-7 (comp level for speech processor) so that the level at TP-2 is not changed when turning the processor on and off. VR-7 should be adjusted for the particular microphone the customer will be using with his TS-820.
6. Finally check for non distortion of signal, and that comp level of 20db can be obtained at full comp on.

This modification is read 845 times.

[top of page](#)

19-07-1998

(TS-820) General Notes on TS-820S

Author: Trio-Kenwood Communication, inc.

Service bulletin no. 21 (25-10-1977)

1. No output TX: SG switch is "OFF".
2. No TX, RX or VFO: There is no 9 Pin plug installed.
3. Low RX Sensitivity, no TX: The transverter switch is "ON."
4. S Meter full deflection when first turned on: Make sure RF gain is not fully CCW.
5. If digital display does not count: Make sure DH is not "ON."
6. If there is no DG display: Make sure you are not in REMOTE VFO with no remote VFO attached.
7. When intermittent in any circuit:
 - a. Check for loose black jumper from point to point on circuit board.
 - b. Check for broken foil path.
 - c. Check for component that has been pulled out or loosely soldered.
 - d. Check for solder splash across foil path.
 - e. Check for loose pins.
 - f. Check for component leads touching to metal IF cans.
 - g. Check for wire not soldered at function switch or at any switch or control.
 - h. When checking FET's, check for excessive voltage at can top usually source, or same G-1, G-2 voltage.
 - i. Check for loose Molex mini connector or any foreign substance on pins.
8. Complaint of frequency shift when TX-CW: This is normal. 800 Hz.
9. Not proper PLL action: Make sure PLL slide switch is in NOR not TUNE.
10. Receiver audio self oscillation at high level: Make sure audio board mounting screws are tight.

RECEIVER

1. Low audio output receiver sensitivity and no transmit: -6v supply is bad. Q13 on FIX VOX unit.
2. 25 kHz calibrator will not zero: Add 3 pf in parallel with TC-1 on the marker unit.
3. Receiver sensitivity down: Q2 on RF unit. +9v on PD unit is shorted. L-6 shorted to ground.
4. Intermittant receive when moving set.: Check for touching terminals at final relay socket.
5. No receiver or digital: 14v wire pinched between DG-1 chassis and ground.
6. Receiver sensitivity 40 db down: Check for shorted L8, 1.8 MHz antenna coil on coil pack.
7. Adjacent signal interference: See TKC bulletin.
8. No receive audio: Check for shorted TA-7201P module at X49-1080-00.
9. Poor receive audio: The 100 V AC 120 V taps were miswired.
10. Receiver doesn't work 20-40: Check for wafer touch to ground on band switch.
11. No DG1, no RX, no TX, no VCO: Bad D1 5 volt zener on relay unit.
12. RIT action seems warbly: See TKC bulletin.
13. Receiver has bad static and is noisy: Bad C14, C15, tantalum on PD unit.
14. VFO frequency shift: Check for loose tension of VFO tension spring.
15. USB/LSB will not work: Check for loose connection at C18 CAR-1 unit.
16. Intermittant audio: Check for loose mounting screws on audio board.

TRANSMITTER

1. Mushy audio on transmit: Mic amps Q20 and Q21 on IF unit are bad.
2. No 14V supply: Bad bridge diodes D8-D10 on X43-1090- 02.
3. Intermittant operation of any one band: Check for loosely soldered Xtals in PD unit.
4. Mic gain down: Cold solder joint at SSB xtal filter IF unit.
5. Self oscillation when TX: Bad final tubes. Burned cathode resistors 10 ohms R2, R3 at final unit.
6. No VOX operation. No sidetone: Burned resistor R12 220 ohms at key socket.
7. No USB or LSB: Check CAR1 X1-X2 crystal for cold solder joint on CAR- 1 unit.
8. No TX: Check for shorted Q1 and Q8 balanced mixer on RF Unit.
9. No ALC meter movement: Readjustment of meter amp VR1, VR2 on IF unit.
10. Intermittant ALC action after peaking drive: One final tube is bad.
11. Fix lite on when in VFO position: Wire shorted terminals on function switch.
12. No loading of TX: Cold solder joint at relay socket RL1 antenna relay.
13. Using Sure 444 speech processor is distorted: See TKC bulletin regarding 16db pad for mic input.
14. No relay closure on TX: Q9 on fix Vox unit is bad.
15. Very low RF output only when using RF speech processor: Bad Q30 on IF unit.
16. Low RF output on SSB without RF speech processor: Bad Q20 on X48- 1150-00.
17. Large audio difference between USB and LSB: realign carrier unit per TKC specifications.
18. No loading on 40 meters: Foil path is open on RF coil pack.
19. No tX when using send switch: Bad R28 1K and Q9 on FIX VOX unit.
20. Blows fuse: Check for shorted C21, C22 100uf 500v.
21. No drive, no TX or bias: Open screen resistor R6 470 ohm at rectfier unit.
22. VFO intermittant: Check for cold solder at VFO power plug.
23. Audio distortion on TX with processor: C96 may be loose on IF board.
24. Faulty LED indications: Check for loose ground screws on LED board.
25. Low output on CW: R14 470 Ohm touch to filter case on IF unit.
26. VOX operation is intermittant: Solder touch VS terminal oand 14v at X50-11350-00).
27. Intermittant TX: Make sure ground strap for 12BY7 shield is under the shield.
28. Insufficient power out to drive linear amplifier: An increase of 5-7 watts can be obtained by paralleling R6 on receiver unit with a 47 ohm 2 watt resistor.
29. VFO output level is down: Q2 inside VFO is bad.
30. No TX or RX on any band. No VCO output: Q14 on X50-1330-00 is bad.
31. No TX or RX: Loose contact VFO output terminal on Fix Vox unit.

This modification is read 1127 times.

[top of page](#)

13-02-2000

(TS-820) TS-820 RIT modification

Author: Trio-Kenwood Communication, inc.

Service bulletin no. 13 (27-1-1977)

We have had a few reports of the TS-820 RIT tuning being "rubbery". The following information will solve this.

How to modify:

1. Remove resistor R27 (1Kohm) on AF-AVR unit (X49-1080-00).
2. Install a 10Kohm resistor on foil side of AF-AVR unit. See figure 1.
3. Install a 1 Kohm resistor on RIT control. See figure 2.
4. Install a capacitor (3.3uF - 10uF) between RIT control and ground. See figure 2.
5. Adjust VR-2 on AF-AVR unit (X49-1080-00) for the same frequency as the center position of the RIT control.

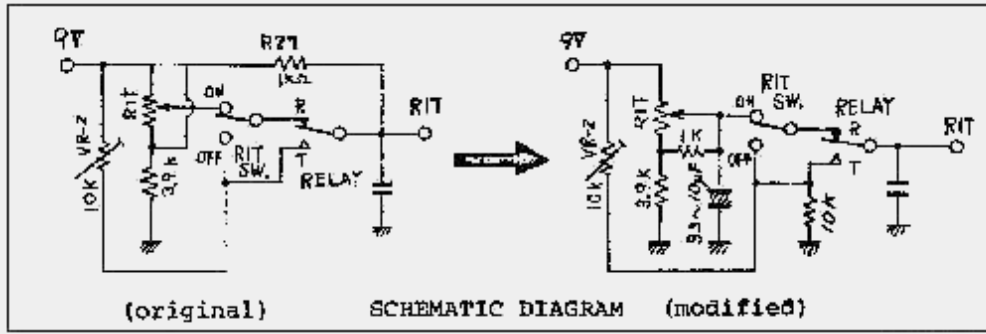
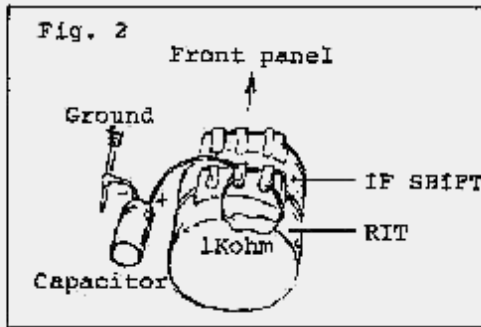
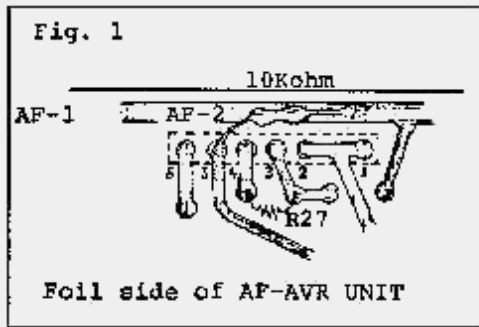

This modification is read 891 times.

[top of page](#)

13-02-2000

(TS-820) Microphone input attenuator for TS-820

Author: Trio-Kenwood Communication, inc.

Service bulletin no. 14 (16-2-1977)

When using a high output microphone (i.e. Shure 444), it is very likely that there will be distortion of the transmitted audio if the processor is used. The reason the distortion occurs is because the processor is between the first microphone amplifier and the microphone gain control. The installation of one of the attenuators shown below will reduce the microphone input to a level that will not cause RF speech processor distortion. The attenuator figures are approximate.

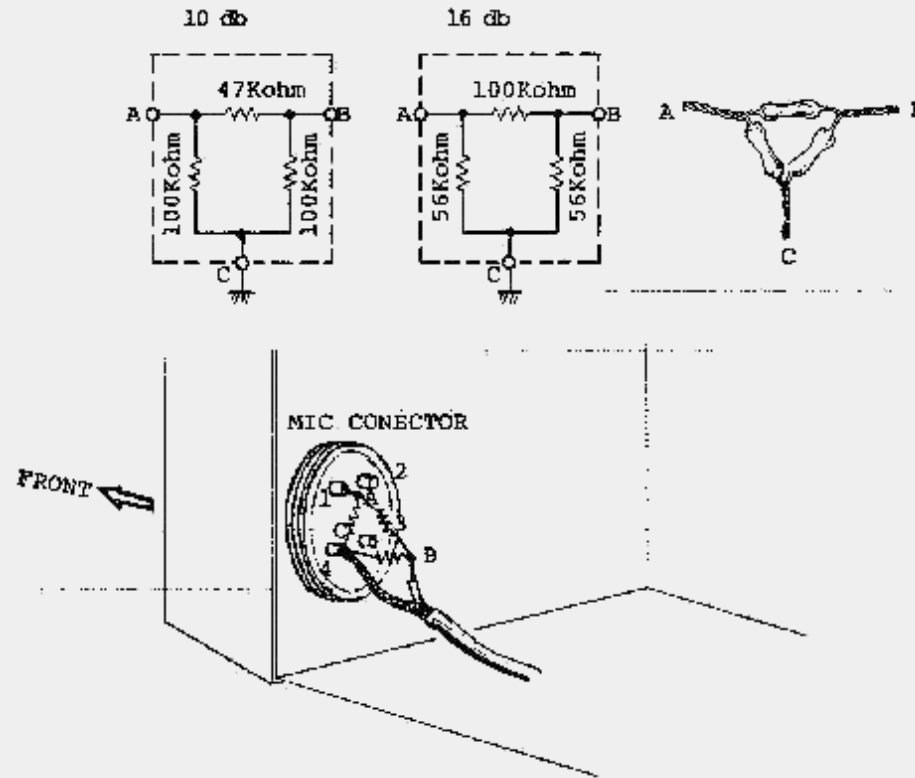

This modification is read 833 times.

[top of page](#)

(TS-820) General Alignment Procedure for the TS-820(s)*Author: Trio-Kenwood Communication, inc.*

Service bulletin no. 30 (14-3-1978)

The purpose of this bulletin is to give a simplified alignment procedure for the TS-820 and TS-820S transceivers. We have tried to combine some of the step and rearranged the sequence of step so the alignment may be done quicker. This may be used in lieu of the alignment procedure in the Service Manual.

1. Adjustment, A.V.R. unit (X49-1080-00)
 - a. Adjust VR1 for 3.3V
 - b. Adjust VR4 for 9V.
2. Adjustment, V.C.O unit (X50-1330-00)
 - a. Place ST to TONE and connect a frequency counter tp TP5.
 - b. Adjust T1-T11 for proper frequency. (See table)

Note from www.mods.dk: I'm not sure about the data in the table are correct, because the drawing i read from was very bad. Have you a better drawing, or can you verify that the frequency are correct then please [mail](mailto:) to me.

Band	Coil	Frequency
WWV	T1	24.08 MHz
1.5	T2	10.88 MHz
3.5	T3	12.88 MHz
7	T4	16.08 MHz
14	T5	23.08 MHz
21	T6	30.08 MHz
28	T7	37.08 MHz
28.5	T8	37.58 MHz
29	T9	28.08 MHz
29.5	T10	28.58 MHz
AUX	T11	Received signal + 0.03 MHz

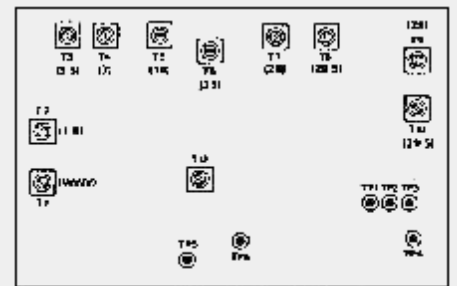

3. Adjustment of coil pack (X44-1140-00)
 - a. Turn screen grid (S.G.) switch (rear panel) OFF, heater switch ON.
 - b. Center DRIVER control.
 - c. Peak coil pack all bands for max. reading on panel meter in TX and RX (except WWV in TX).

Another note from www.mods.dk: I'm not sure about the data in the table are correct, because the drawing i read from was very bad. Have you a better drawing, or can you verify that the frequency are correct then please [mail](mailto:) to me.

Adjustment sequency	Band	VFO meate
1	1.8	100
2	3.5	250
3	7	150
4	14	175
5	WWV	0 : 15.0 MHz
6	21	225
7	28.5	500

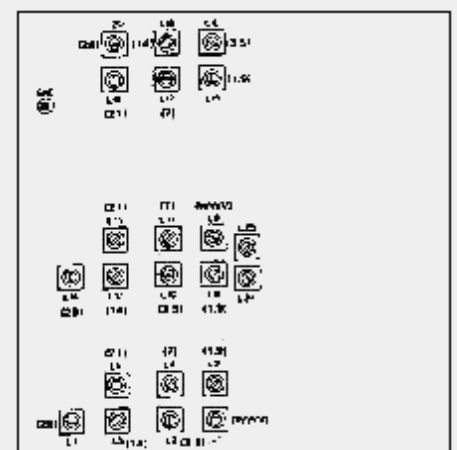

4. Carrier point (X50-1310-00)
 - a. Peak TX power in CW mode. Then switch to LSB and modulate with Audio Gen. (A.G.) @ 5 mv 1500Hz while reducing mic. gain to 500 Watts outputs.
 - b. In the CW mode connect a frequency counter to TP5 on the IF unit (X48-1150-00) and adjust TC1 on the CAR-2 Unit (X50-1320-00) for 8.830.7 MHz.
 - c. Adjust VR1 o the CAR-1 Unit (X50-1310-00) for equal output freq. on USB and LSB.

- d. In LSB mode, check the RX and TX frequency at TP5 on the IF Unit. It should not change.
- e. With mode switch in LSB position Audio Gen. input @ 5mv, vary input frequency from 400Hz to 2600Hz and check for BALANCED output while monitoring on scope LSB to USB and vice versa.

5. Speech processor (X48-1150-00)

- a. Tune TX for maximum output power at 14.175 MHz.
- b. Set mic. gain in center and S.G. off, comp meter ON.
- c. Place scope on TP2 and counter on TP3.
- d. Set A.G. for 10mv @ 1500Hz and modulate unit.
- e. Turn processor max. "ON" position, and adjust TC4 to 451.9 ± 200 Hz. Adjust T11, T12, T13 for peak indication on COMP. meter.
- f. Peak T14 by scope on TP2.
- g. Turn processor full C.C.W.. and reduce A.G. gain to 1mv @ 400Hz.
- h. Adjust TC4 for max. level n scope but at proper frequency. (451.9 ± 200 Hz) (May adjust slightly off frequency if higher peak can be obtained.)
- i. Sweep A.G. frequency from 400Hz to 2000Hz and check for balanced output on LSB and USB.
- j. COMP. full clockwise and @ 1500Hz adjust TC3 and VR6 for min. reading on COMP. meter.
- k. At 1500Hz @ 10mv adjust VR7 to balance processor in "ON" and "OFF" positions (same level).

6. Balance mod. adjustment (X48-1150-00)

- a. In CW position adjust TX for max. output. Key unit with mode switch in SSB position (no Mod.).
- b. Adjust VR5 and TC2 for min. output level on scope.
- c. Check BALANCED output LSB and USB.

7. Neutralization

- a. S.G. switch turned off after TX has been tuned in CW mode at 21.3MHz.
- b. Adjust neutralization cap in final cage for min. output as seen on scope.

This modification is read 972 times.

[top of page](#)

02-04-2000

(TS-820) DS-2 Replaces DS-1A DC-DC Converter

Author: Trio-Kenwood Communication, inc.

Service Bulletin no. 842 (26-1-1981)

The DS-1A DC-DC converter for the TS-820 series and TS-520/S has been replaced by a new model, the DS-2. Wiring color code is the same. Physical size is smaller. Two additional mounting holes must be drilled in the transceiver rear panel.

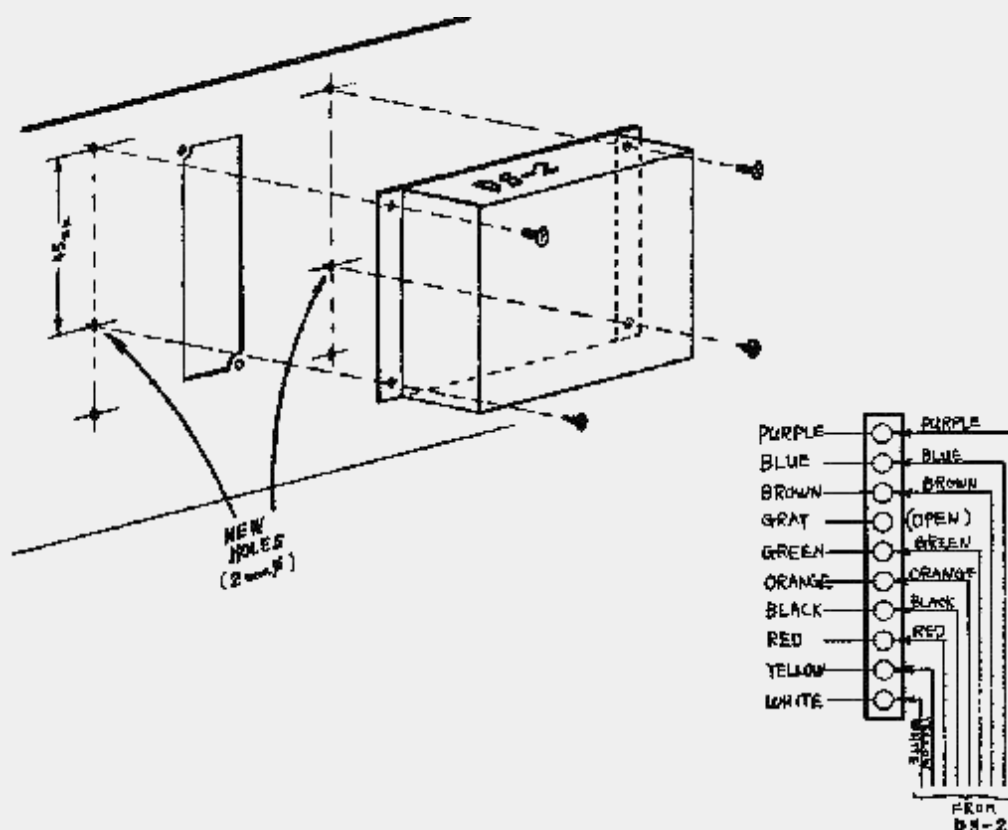

19-07-1998**(TS-830) Modification to TS-830S, TS-530S**

Subscriber's comments on qro modification to TS-830S, TS-530S and TS-530SP

I would like to pass on the problem I have encountered in connection with the QRO modification to the Kenwood radios TS830S, TS-530S and the TS-530SP.

The problem occurs after many hours of long winded QSO's. It seems that with the increase in the screen voltage from 210 to 300 volts, R37 on the RF unit (#X44-1360-00) heats up tremendously and will change it's value so greatly that even the receive either suffers or goes out totally. R37 originally is Metalfilm resistor at 3.3K ohms and is 1/2 watt.

I have changed mine to a Metalfilm as original same value but have used a one watt resistor. The brand I was able to get was RCA and I suppose there are better on the market. This is a 2% tolerance. Three units that I know of have had this problem that I took care of in this area alone. Two units were TS-830S and one a TS-530SP. Just thought I would pass that information along for what it is worth. (Thanks, Frank J. Lukas, Jr., 5301 Main Ave., North Ridgeville, OH 44039)

This modification is read 1773 times.

[top of page](#)**19-07-1998****(TS-830) TS-830S Frequency Shift**

Author: Trio-Kenwood Communication, inc.

Service Bulletin no. 840 (14-4-1982)

Some users may report an intermittent shift in the display and operating frequency. This may typically be a 1 to 4 kHz random shift. Cause will be a loose grounding screw on the AF/AVR unit heat sink.

On the AF/AVR unit X49-1140-00, there are three self-tapping screws holding the aluminum heat sink to the PCB. These also supply the ground connection to that section of the board. Between the heat sink and PCB foil, add a tooth-lockwasher N17-1030-41 at eht two self-tapping screws on the side of the heatsink that has the two transistors attached. (The remaining screw already has a lock washer.)

When replacing the board to the chassis, add a solder lug E23-0420-05 to the heat sink mounting screw as shown, and tighten all screws for this board. Solder an insulated lead between the TPG (Test Point Ground) wrap post adjacent to C81, and the added solder lug.

Procedure:

1. Remove the top cover (8 screws) and unplug the speaker.
2. Remove the bottom cover (8 screws).
3. Remove 5 screws holding the AF/AVR unit and swing the board over. Leads do not have to be unplugged.
4. Add two tooth-lock washer as shown.
5. Replace the circuit board and heat sink to the chassis, adding the solder lug as shown.
6. Solder a jumper between the TPG wrap post and the added solder lug.
7. Replace the top and bottom covers.

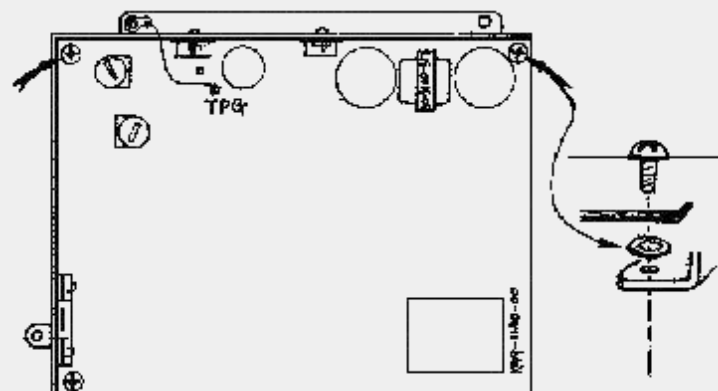

Installation time for this procedure is 1/2 hour or less.

19-07-1998**(TS-830) Amtor modification**

1. Remove C500 (4.7uF) on the signal board (located top center near connector 30).
2. Ground the junction of R-476/Q-100.
3. This will provide a very noticeable decrease in switching time.

19-07-1998**(TS-830) Warc modification**

1. In early TS-830's, the WARC transmit was not enabled.
2. If this is the case, solder a jumper wire from Pin 12 of IC-23 to ground on the DIGITAL UNIT PCB. Ground can be obtained at Pin 8 of IC-4.

19-07-1998**(TS-830) VFO-230 fine tune mod correction**

A note published in your t/k newsletter of january, 1983, issue no. 30, concerning a fine tuning mod for the vfo-230, impelled me to purchase a new vfo-230 for the sole purpose of obtaining a slower dial tuning rate for my ts-380s. then the combination of a defective new vfo-230 and some bad information in your newsletter note triggered many, many hours of frustration and irritation over a period of several months starting in june 1986. i believe you should know about it when information in your newsletter causes frustration and irritation.

I decided to try the diode cutting bit again. it did not work. the optical dial encoder went crazy. i was ready to explode and did. Fortunately there was nobody around to hear me. back to the drawing board. now i know practically nothing about optical encoders but i do have an engineering background so i spent some time staring at the vfo-230 schematic in the ts-830s service manual. suddenly the light came on. ka0nnf gave you the wrong information about which diodes to cut. (his call is not wa0nnf as given in your newsletter note. i tracked him down by telephone. he told me he had sold the vfo-230 and couldn't remember.)

The proper diodes to cut for 6-1/4 khz per dial rev. are d19, d20, d22, d23, d24, and d26. i presume cutting diodes d19, d21, d22, d23, d25, and d26 would also work but i will leave that for someone else to try. in other words, of the eight diodes, cut all but d21 and d25 or d20 and d24 for 6/14 khz per dial revolution.

that's the end of the story. my vfo-230 now works perfectly at 6-1/4 khz per dial revolution. this jpermits me to use the excellent ts-830s receiver on 160m cw with very extreme if (250 hz) and external audio (50 hz) selectivity. incidentally, i wonder how many repair facilities (including yours) are equipped to motor drive the vfo-230 dial shaft at 300 rpm while observing the optical encoder waveform? this alignment procedure is necessary, and is prescribed in the service manual, before you should expect the encoder to work at slower than the "stock" rate. (i think this was part of the problem).

19-07-1998**(TS-830) TS-830S Low Voltage Supply Optional Improvements**

Power supply drift and stability may be improved by these optional component changes and additions.

On the AF AVR unit X49-1140-00 (Vicinity of Q27-Q30) change:

R124 from 1K to 1.5K (RD14CB2E152J)*
 R127 from 470 to 390 (RD14CB2E391J)*
 R130 from 47K to 33K (RD14CB2E333J)#
 D25 from WZ-061 to XZ-053 (V11-4101-60)*

*This will improve temperature drift from a maximum of about 100mV to a maximum of 1mV, and may be applied to any unit before serial # 201xxxx.

Add two 22 k ohm 1/4 resistors (RD14CB2E223J0, one each across Q30, and Q34, collector to emitter.#

#This will improve overall stability and may be applied to any unit before serial #105xxxx.

Note:
 These changes are at the owners option and may not be performed in-warranty.

This modification is read 1184 times.

[top of page](#)

24-01-1999

(TS-830) Kenwood TS-830 filter modification

Here is an easy filter modification for the kenwood ts-830s. first to use this mod, your rig need the yk-88c and to mak t even better, the yg-455c installed. in short what we are going to do, is move around a 9 volt switching voltage. this voltage comes from the af board, connector no. 7, pin no. 5. its marked rlr on the schematic. this voltage ends up at the pll assembly, connector no. 8, pin novp2. please do try this modification by cutting in this circuit at he source, because this same switching voltage feeds the if shiqo circuit, and the vbt circuit, and the pll. so cutting the wire at the af board will make the pll unlock when the mode switch is anywhere but in the cw positions. now to te prtceires.

1. Remove the top and bottom covers, and turn the radio upside down with front facing you.
2. Locate the mode switch, and on the middle wafer set of contacts, cut the white wire with the blue stripe. it is located next to the terminal with no conn ction, on the middle wafer set of contacts9)3-;3 about 1/4 inch ox wire on t switch contact, so youcan make a connection there later.
3. You will need a another switch, one with at least three terminals, with the center teminal always in contact with one or the other of the outside contacts. its best to use a toggle type so you can mount it in one of the spare holes on the back of the radio.
4. Splice into the wire removed from the moeoppich, and connect this wire to the center of your new switch.
5. From one (you select) of the side terminals of the new switch, connect a wire and run it back to the mode switch. connect this wire to t tminalon the mode switchnrom which you removed the white wire with the blue stripe. you did leave that 1/4 inch of wire didn't you? take care here, the grey wire next to the one you are working on carries 110 volts, so don't make any solder shorts!
6. Now from the remaining terminal of your new switch, connect and run a wire to the if board to pins cw1-cw4. connect this wire to the green wire, that is connected to one of these pins. you will then have two wires connected to one of these terminals.
7. Make sure tu have no solder shorts or bridges, make sure you have taped or insulated any bare wire connections. mount new switch in one of the spare holes on the baccof the radio. install the top aod bottom covers.

The modification works great, one position on the new switch and everything isnormal, in the other position the cw filter is placed in-line regardless of the position of the mode switch. to use the cw filters on rtty/amtor i found i had to turn the if shift control ccw to about the 9:30 position to center the tones in the passband. if you need an even narrower passband, just tighten it up a little with the vbt.

This modification is read 1356 times.

[top of page](#)

02-04-2000

(TS-830) TS-830S Operation on 240V AC

Author: Trio-Kenwood Communication, inc.

Service Bulletin no. 837 (15-12-1980)

To operate the TS-830S on 240V AC, the power transformer split primaries must be rewired from parallel to series connection.

1. Unplug the AC power cable.
2. Remove the bottom cover.
3. Remove the jumper wires between the two \emptyset terminals and two 120 terminals on the bottom of the power transformer.
4. Connect the adjacent 120 and \emptyset terminals at the middle of the transformer. This will provide 240V AC operation.

For 220V AC operation, connect the adjacent 100 to \emptyset winding.

5. Change the AC fuse from 6A to 4A. Tag the power cord at the back of the radio to indicate that the transformer is strapped for 240V AC, and the power fuse should be 4A, and not 6A.
6. Replace the bottom cover and reconnect power to verify your work.

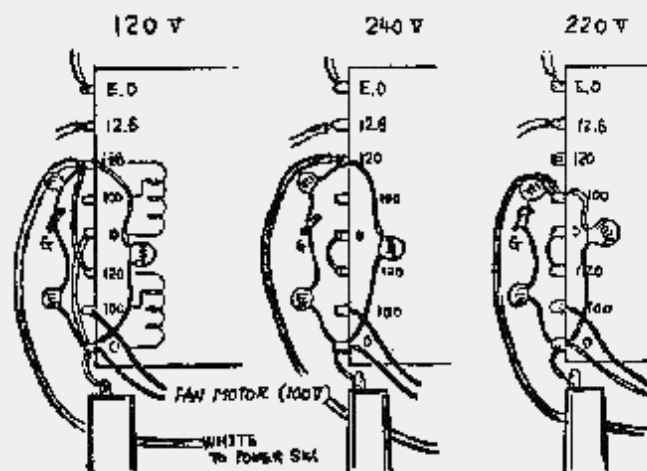

This modification is read 1148 times.

[top of page](#)

02-04-2000

(TS-830) TS-830S Low voltage Supply Optional Improvements

Author: Trio-Kenwood Communication, inc.

Service Bulletin no. 847 (14-4-1982)

Power supply drift and stability may be improved by these optional components changes and additions.

On the AF AVR unit X49-1140-00 (Vicinity of Q27-Q30) changes:

R124 from 1 Kohm to 1.5 Kohm (RD14CB2E152J) *
R127 from 470 ohm to 390 ohm (RD14CB2E391J) *
R130 from 47 Kohm to 33 Kohm (RD14CB2E333J) *
D25 from WZ-061 to XZ-053 (V11-4101-60) *

* This will improve temperature drift from a maximum of about 100mV to a maximum of 10 mV, and may be applied to any unit before serial # 201xxxx.

Add two 22 Kohm 1/4W resistors (RD14CB2E223J), one each across Q30 & Q34, collector to emitter. *

* This will improve overall stability and may be applied to any unit before serial # 105xxxx.

Note: These changes are at the owners option and may not be performed in-warranty.

This modification is read 1144 times.

[top of page](#)

08-04-2000

(TS-830) TS-830S Noise Blanker Optional Improvements

Author: Trio-Kenwood Communication, inc.

Service Bulletin no. 851 (26-7-1982)

Receiver Cross-modulation while using the noise blanker may be improved by these optional component changes and additions. Realignment is not required.

At the Noise Blanker level control VR8, change R19 from 22 ohm to 15 ohm (RD14BB2E150J)*

On the AF AVR unit X49-1140-00 (vicinity of Q20) change:
D22 from an MV-13 to an MV-203 (VII-3379-16)*
R96 from 2.2 Kohm to 820 ohm (RD14CB2E821J)*

(vicinity of Q24)

R112 from 47 Kohm to 56 Kohm (RD14CB2E563J)*

Across T2, (Fig. 1) add a 12 Kohm (RD14CB2E123J)*

At Q21 (Fig. 2,3) add 2 pcs. 680 ohm (RD14CB2E681J) *

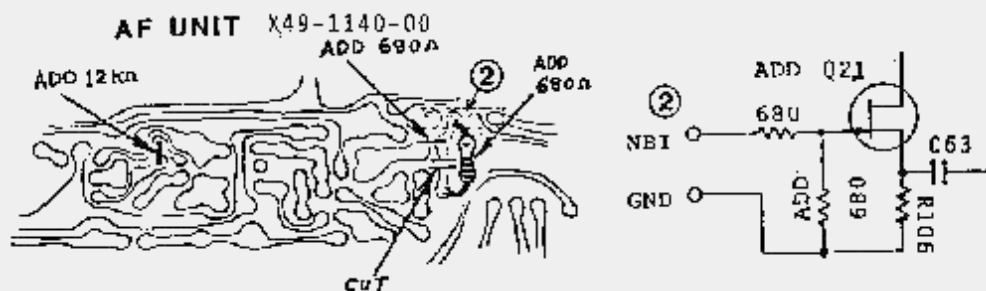
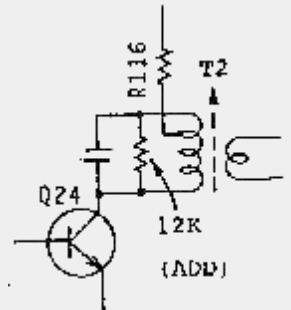

Note:

1. Applies to any unit before serial: 2010000*, 1120950*, 1132058*.
2. These changes may be performed in-warranty.

This modification is read 1244 times.

[top of page](#)

08-04-2000

(TS-830) TS-830S Transmitter "Talkback"

Author: Trio-Kenwood Communication, inc.

Service Bulletin no. 857 (11-2-1982)

Transmitter "talkback", either with or without a linear amplifier, may be eliminated by adding a filter at the receiver audio power amplifier.

On the AF unit X49-1140-00 at Q4, cut the 12V DC B+ line between R47 and C28, and add a 1uH choke (L40-1092-02) in-line. Add a .01uF cap (C52-1710-36) from the IC pin 1 to ground, as shown using a 3 mm lug (E23-0015-04) under the IC mounting screw on the Heat Sink.

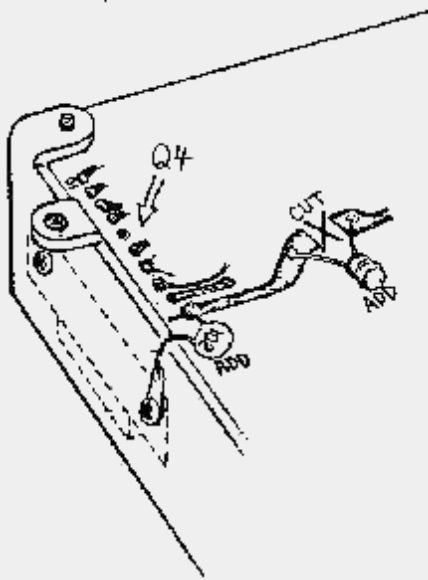

Installation time for this procedure is ½ hour or less.

This modification is read 1259 times.

[top of page](#)

19-05-2001

(TS-830) TS-830 Frequency Drift

Author: Tommy Hayes - tah@txucom.net. MODIFICATION.NET

Before making any internal modifications for the freq. drift please try this.

Take both the top and bottom covers of the rig off the the transceiver. Find each and every phillips screw that you can get to with a phillips screw driver and loosen it about 1/4 of the way. After doing that, retighten the screws.

This includes but is not limited ti each and every PC bord that you can get to. Done this with my 830 that had severe drifting problems and so far (4 months) have not had a problem with the drift yet on any band.

Hope that this proves to cure.

73s and Gud DX Tommy (N5PJY)

This modification is read 1352 times.

[top of page](#)

30-09-2001

(TS-830) TS-830S Frequency Drift - "FIX" switch

Author: Alan N5LF

If your TS-830S drifts or jumps frequency up & down 100 to 200 hz, the problem may be a dirty FIX switch. The FIX switch disables the VFO and is used for crystal control. The switch conducts voltage in both the on (crystal) and off (VFO) positions. Dirt, corrosion, or wear makes the switch provide uneven voltage to the VFO and therefore causes the drift/jumping.

To test for this problem, wiggle the FIX switch or press it in & out a few times and see if the drift/jumping stops for a few minutes.

Temporary cure: Spray the switch with contact cleaner. This works for me for 1 to 3 months, then it starts acting up again.

Permanent cure: Use a jumper to bypass the switch, so it is permanently in VFO position.

If someone knows a solution that doesn't disable the FIX switch's function, please let us all know.

Alan N5LF

This modification is read 1337 times.

[top of page](#)

19-07-1998

(TS-850) TS-850S observations

Observations of KC2CT

Having lived with Kenwood's TS-850S transceiver for 5 days, here are some of my observations:

- While the manual shows 35 power-on front panel adjustments, there really are 36. Function number 35 is set from the factory to the OFF state. Well, what exactly is this unknown function? Well Bunkies, this enables the transceiver to transmit on 27.500 through 28.000 mhz! Do yourself a favor, and set this option to ON for TX inhibit! DO NOT JEAPORDIZE YOUR LICENSE! Why in the world did the factory allow this??? Maybe they don't want the Chicken Banders butchering up the rigs....
- Tone control. The setup only allows Burst or Continuous modes, there is no way to turn it OFF, even though the manual indicates there is a way.
- Quick memory function. You MUST pass through either the VFO A or VFO B registers to program these.. You cannot go from standard memory to quick memory directly.
- My 850S came out of the box running low power (50 - 75w PEP), so I called the local ham radio dealer inquiring about service manual availability. Well they had them in stock, but at a price of \$50.00! Unbelievable! Kenwood wants fifty dollars for (in the continuing Kenwood tradition) a terribly organized, incomplete, and horrible reading manual!!! Well, I dug into the schematics and opened up the the radio, here's a list of items that might be of interest to some:

RF Board Controls

VR - RX BAL
VR - TX BIAS
VR - TX BAL
VR - TYP (50W output power adjust, used with S1 below)
VR - MIN (?????) / internal antenna tuner
VR - TUN (Tune mode power adjust)
VR - VSF (THIS IS THE 100W POWER OUTPUT CONTROL)
VR - SWR Protect activation
VR - PWM (Forward power meter calibration)
VR1 - RWM (Reflected power meter calibration)
VR1 - AL0 (ALC meter zero)
VR1 - ALM (ALC meter calibration)
VR1 - CPM (Processor meter calibration)
VR1 - ALG (ALC gain adjustment)

S - All Band Power Down Switch (Decreases power to 50 watts)

IF Board Controls

VR -
VR -
VR -
VR - Beep volume
VR - Sidetone volume
VR - Processor adjust
VR - ??????
VR8 & VR9 - ??????
VR1 - ??????
VR1 -
VR12 & VR13 - S Meter adjust
VR14 & VR15 - AGC adjust
VR1 - Notch filter adjust

- **PLEASE NOTE!**
Most of these controls are 1/8" pots, so if you intend to adjust them use a VERY SMALL non-metallic tool.
- My 850S also came out of the box with the RIT/XIT control not displaying 0.00 khz at fiducial (12 o'clock position) center. Behind the front panel in the upper right corner is the control for center adjust. It just needed a wee bit of tweaking... Along with this control on the circuit board are the master adjustments for the SSB slope tuning (High Cut and Low Cut).
- When both top and bottom covers are removed, on the left-hand side is the FM board. There are 3 (three) pots on the board. They are FM Wide (12khz) deviation, FM Narrow (6khz) deviation, and FM Mic gain.
- FM mode defaults to WIDE (12khz). This is WAY too wide for accessing any 10m repeater. Hit the 455khz filter button again for FM-N (narrow). This will set the IF to 6khz width, and you be able to work FM 10m stations. Note: The 8.83 filters are NOT selectable in FM mode.
- Memory scrolling via M CH./VFO CH. You can bypass all unused channels if you press the 1 mhz button. With the button active, only stored memory channels will be displayed as the knob is rotated.
- Tuneable memories. Out of the box, the radio is set up for non-tuneable memories. Just bring up setup function xx on the display, and set it to ON, and ALL memories can be tuned via the VFO. When use the M.CH/VFO CH. switch you will be returned to the original frequency & mode setting in the memory.
- It may or may not be obvious to some, but the radio is capable of cross-band and/or cross-mode operation. Just pump the required modes and frequencies into memory channels or VFOs, and you're off and running. Hope you have a very broadbanded antenna!
- CW message storage is lost when you power off the radio. I didn't order the DRU-2 option (yet), so I don't know whether these

messages will be saved. You'd think that with everything else that is stored in RAM and backed up by battery, that Kenwood would have made provisions to keep recorded messages alive also. A modification????

- When adding additional filters, it is necessary to set the corresponding switch on. Under the hatch on top, is a 4 position dip switch. The manual shows a picture of it, but makes no mention of their settings. This switch is necessary to inform the micro-processor of the filters' absence or presence. ON is for presence, OFF is for absence. Below is the switch diagram:

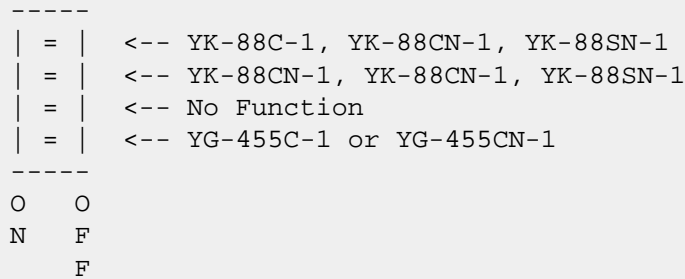

- I received the DRU-2, voice recording unit this week, and installed it. Here's what I found:
- The unit comes with a lithium battery for backing up the voice messages when the rig is powered off.
- The initial state of the DRU-2 is:

Message 1 - 8 seconds
Message 2 - 8 seconds
Message 3 - 16 seconds

You can halve the sampling rate via front panel setup control xx. This will effectively DOUBLE the time of each message, however, the quality of voice reproduction will suffer because of the lower sampling rate.

- On playback of the messages, the microphone IS NOT disabled, so be quiet when you're transmitting stored messages.
- Use the MONI function to hear what you've recorded and/or are transmitting, and the MIC gain control to keep the ALC in range, as the DRU-2 drives the radio much harder than the microphone input.
- The high boost function and speech processor are available to the DRU-2 during transmit.
- I also got the VS-2 voice unit. The voice is the same as the older VS-1 for the TS-440, and TS-940, but the unit is in a smaller package. It will speak the frequency in either English or Japanese. There is a volume control pot on the bottom of the board which should be adjusted PRIOR to screwing down the VS-2. The output on my unit was very low, until I tweaked it up. Also there are jumpers on the board to speed up the voice playback... You'll need to consult the instruction page for the VS-1 for speeds, as there is nothing mentioned in the instructions for the VS-2.
- A note on output power of the rig. The radio uses 2SC2789's... These devices are rated as 100 watt devices Kenwood is running the finals VERY conservatively. When playing around with output, I had the rig dead-keying 175 watts, but backed it down to 100 watts, as I didn't want to blow up the rig, but I was definitely smiling as the Birds' meter swung with a 250 watt slug!
- The ROM chip on the digital board is socketed. Kenwood had problems with early 440's and 940's with poor soldered connections. While it's a nice idea to allow removal and replacement of the ROM to add features/fix bugs, this might become a problem area in the future.
- Hidden function!!! If you turn on the radio while holding down the VOICE button, EVERY button on the radio will acknowledge its function via morse code! This is a terrific feature for sightless hams! I can't understand why it is not mentioned in the owners manual or marketing literature!

This modification is read 2209 times.

[top of page](#)

19-07-1998

(TS-850) TS-850S All band transmit

Kenwood markets this radio worldwide, and has made provisions to allow the radio to transmit between 1.625 mhz and 29.999 mhz. I am providing this modification for INFORMATIONAL PURPOSES ONLY! DO NOT TRANSMIT OUT OF BAND, THIS WILL JEOPARDIZE YOUR LICENSE, AND HAVE THE FCC, AND/OR INTERNATIONAL AUTHORITIES KNOCKING AT YOUR DOOR!!!

The All-band transmit modification requires the removal and re-location of a diode on the the digital board which is located behind the front panel. The US version of the radio has diode D11 installed, and diode D9 removed. D11 must be removed, and installed in the D9 position. This modification IS NOT for the faint of heart, as it entails removing the front panel, and the digital board. Note that the digital board has solder holes that are through-soldered; that is, there are circuit traces on both sides of the board, so make sure that ALL solder is removed from the holes. This modification will also allow the antenna tuner to tune anywhere the receiver is tuned. This modification should ONLY be performed by those familiar with soldering and de-soldering techniques, and requires patience, and dexterity.

This modification is read 2504 times.

[top of page](#)

19-07-1998

(TS-850) TS-850S Broadcast Band Sensitivity

BCB sensitivity REALLY suffers as a 24db attenuator is inserted when band-switched. This attenuator circuit is very similiar to the TS-430/440. Possible modification?

This modification is read 1733 times.

[top of page](#)

19-07-1998

(TS-850) TS-850S Additional Front Panel Functions

Pressing SCAN + TX-M.CH will set the radio into its extended function mode. These options can be scrolled via the M.CH/VFO CH. switch. The following are the extended functions:

- 00 - This is the ROM Cèecksum displayed as a 4-digit hexadecimal number This cannot be changed.
- 01 - Allow filter selection in transmit. Initially set OFF.
- 02 - Antenna tuner power down. Initially set to OFF.
- 03 - Antenna tuner non-stop mode. When set to on, the antenna tuner will not stop when the lowest VSWR is found. Initially set to OFF.
- 04 - Store mode, and filter settings prior to changing bands, or cèannels. Initially set to ON.
- 05 - Display -HELLO- on digital display, anã send it in Morse code on power up. Initially set OFF.
- 06 - Turn full LCD display ON on power on. Initially set OFF.
- 07 - Turn Subtone ON or OFF. Initiãlly set ON. Note tèat even when set off, the TONE indicator will be lit on the display.
- 08 - Unknown. Initially set OFF.

This modification is read 2228 times.

[top of page](#)

19-07-1998

(TS-850) Step by step instructions to disable the broadcast band attenuation for TS-850S

This mod greatly improves the sensitivity and likewise the reception on the AM broadcast band.

No noticable unwanted side effects have occured following this procedure.

I live within three miles of a 5,000 watt broadcast station on 1150 kc's and am able to listen to stations on either side of that station. There is some splatter but using the notch filter and the attenuation on the front of the radio takes care of that for the most part. This is *NOT* complicated and can be done in fifteen minutes. Only one caution here:

you WILL BE SOLDERING TWO POINTS ON A CIRCUIT BOARD THAT IS LOADED WITH SURFACE MOUNTED COMPONENTS!!! There is little room to work on the board, so be very careful with your iron! If you don't feel comfortable soldering, get someone else to do it as you can cause a solder bridge and ruin your radio without even trying. With that in mind, here goes:

1. remove the eleven screws that secure the bottom cover to the rig. the six ones on the sides and the five on the bottom cover itself.
2. remove the bottom cover. there are no wires attached to the cover. lift it right off. leave the top cover of the radio ON.
3. locate the RF BOARD. it's number is: X44-3120-00. this is the board where you plug the optional filters into. with the open radio in front of you, and the front of the radio facing you, the RF BOARD is the one on the left. (there are only two boards under the bottom cover)
4. locate the chrome like shield on the rear of the RF BOARD. it's made out of shiney steel. remove the four screws that hold this shield to the board.
5. remove the shield by lifting the front of it up while sliding it forwards, towards you. watch out for all the little wires and ribbon cables going to and from the RF BOARD.
6. look at the rear of the board and towards the left corner. (the radio is stil facing you upside down) notice two I/C's numbered IC1 and IC2. directly behind the I/C's are a bank of adjustable coils in metal cans. there are nine of these coils in a group. directly to the left of these coils are many green and red inductors which are standing up. they look like resistors but they're really small coils.
7. these inductors are part of the bandpass filtering for each of the bands on the radio. the capacitors and resistors that complete

the bandpass filtering are on the other side of the board and are of the surface mount type. you are only concerned with the bandpass filter for the .5 to 1.6 band. notice the numbers for the inductors. find L8 and L9. they are right at the edge of the board in the left rear corner you will notice that .5 - 1.6 is stamped right next to L9. BINGO! you have found the part of the circuit that you will modify.

8. look at where the .5 - 1.6 is stamped on the board next to L9. you will see two bronze or gold solder points there directly next to the numbers .5 - 1.6 . there is nothing soldered at those two points. this is where you will solder a jumper wire between the bronze points. do NOT confuse it with the other two solder points with the line running in between them next to the phillips head screw!!! you want the two points that are spaced very close together that is right next to L9.
9. you will have to do the soldering on the OTHER SIDE OF THE BOARD. remove the nine phillips head screws that hold the RF BOARD to the chasis.
10. on the back of the radio, look for the switch stamped SW 1. it's right below the grounding post and has the two postions: INT and EXT. remove the two screws that hold the switch to the back of the rig. the switch is soldered to the RF BOARD and you wont be able to lift the board up until the screws are removed.
11. unplug enough cables from the board so you'll have enough room to lift the RF BOARD up to solder the jumper. there is no need to remove the board from the rig. slide it towards the front of the rig until the switch SW 1 clears the back of the rig and lift the left side of the board up and prop it up with a small block of wood.
12. locate the bronze solder points on the underside of the board. there will be a small amount of solder at these two points on the underside of the board.
13. bend a small jumper out of wire that fits the two bronze points on top of the RF BOARD. you will place the jumper on the top and solder on the underside of the board. with a pair of needle nosed pliers, place the jumper into the holes and simply heat up the existing solder on the underside until the jumper slips down farther into the holes.
you'll notice the large amount of components on the underside versus the lack of components on the top of the board. be carefull when heating the solder on the two points. you don'y want to disturb the surface mounted parts or cause any excess solder to run onto them or the foil nearby.
14. you are now done. re-assemble in reverse order, plugging the wires back in carefully, making sure they don't get plugged into the wrong place. also, avoid pinching them when replacing covers.

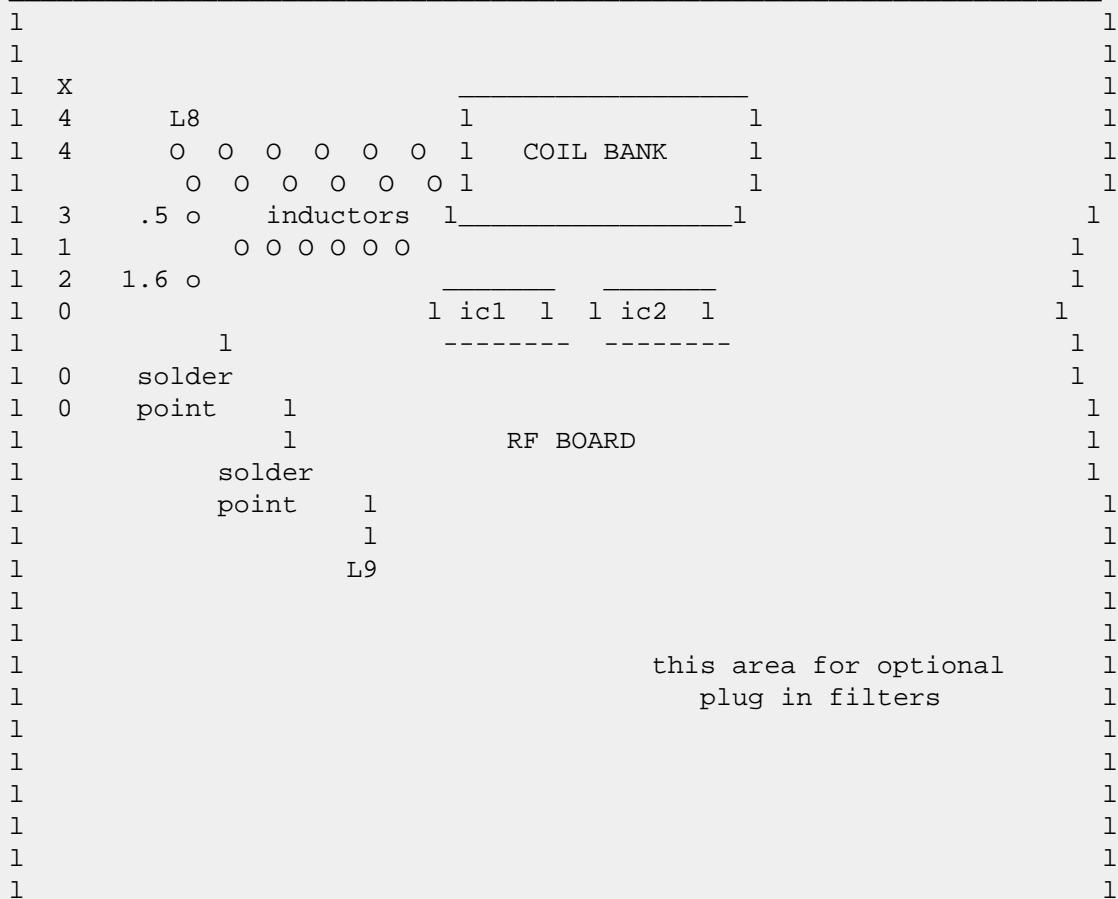

FRONT OF RADIO

Sorry, that's the best art work I can do. The purpose of the jumper is to bypass the two 150 ohm resistors that are in series after the bandpass filter. The resistors add between 20 and 25 db attenuation to the AM broadcast band. For some reason, Kenwood thinks that the receiver would become overloaded by strong nearby broadcasting stations, which would cause distortion. I simply don't find that to be the case. It's funny, Kenwood already had those two points there on the board, but without the jumper.....it seems to me that they had anticipated the need to bypass the attenuation in Europe or Asia. Thus, all export models going to the states were missing that jumper. Who knows? I can't find any other reason for the jumper points to be there.

Anyway, you'll notice an immediate increase of signal strength. You'll hear stations that you never knew were there! As I said, if you are bothered by strong stations in your area, try using the 6 and/or 12db attenuation buttons on the front of the rig.

19-07-1998

(TS-850) TS-850? ACC-2 audio problem

Following bulletin was sent to me by Dick, KB8DB:

KENWOOD/KAM SSB AUDIO PROBLEM

The problem is that some kenwood radios are being shipped with the rear panel audio output very sensitive. We (kantronics) have had others report the same problem, and the following response was prepared by our service department: Some adjustments in the radio and in the kam may be necessary when using these connections. SOLUTION:

Decrease the gain in the kenwood radio rear panel audio input circuit (may be labeled vr18, check your radio manual).

Increase the afsk output from the kam (remove jumper k5 for maximum output).

Set the kam to transmit in rtty mode, and radio in ssb mode, adjust vr18 (or gain control in radio that controls rear panel audio input) for the radio manufacturer's recommended output when using rtty.

Now, when using the front panel microphone, low-level noise on the rear panel input will not be picked up or added to microphone audio. (unquote)

73 from Stan G4KSJ @ GB7BEN.#43.GBR.EU

This modification is read 1723 times.

[top of page](#)

19-07-1998

(TS-850) Adjustable moni. on CW, TS-850S

Hello everybody!

If you'd like to be able to adjust the volume with your "MONI-knob" on the frontpanel of your TS-850S when monitoring your transmission on CW read this! Originally it's a fixed level controlled by VR5 internally.

This could be usefull when switching between the loudspeaker and the headphones.

When you're monitoring your CW with headphones at a pleasent level, and then disconnect the headphones and monitoring with the loudspeaker the audio is quite low.

(IF-UNIT)

- Remove the IF-UNIT (you must solder on the rear side of the IF-UNIT). Be carefull to mark all the cables before you remove them!!!
- Remove R239 (330 kohm, close to VR5).
- Install a new resistor (330 kohm) from the output of VR5 to the junction R229, R230, R231 and C172 (rear side of the IF-UNIT, close to IC7).
- Adjust VR5 to maximum audio level.

Now you're able to adjust your audio level in the CW mode with the "MONI-knob" at the frontpanel of your transeiver.

Gif file of the circuit board [layout](#) (445 Kb) where the mod is to be done in the radio.

73 de Nate Bargmann

Packet: KAORNY @ WFOA.#SCKS.KS.USA.NOAM

E-mail: ka0rny@midusa.net

Valley Center, Kansas USA EM17hs

Visit my Linux + Ham Radio pages homepage.netspaceonline.com/~ka0rny/

This modification is read 1623 times.

[top of page](#)

19-07-1998

(TS-850) TS-850 service manual, error corection

Page 20:

2 Full break-in operation timing

...signal enters pin 10 of the BW-SW module from the...
should be
...signal enters pin 10 of the BK-IN module from the...

Page 21:

Resistor R3 (10 kohm) in the BK-SW schematic does not exist.
(This is corrected in the schematic that's in the user's manual)

Page 23:

Key up

In line 8 and 10 capacitor C230 is mentioned
-should be C231

This modification is read 1853 times.

[top of page](#)

19-07-1998

(TS-850) TS-850S and speaker/headph

This is a very simple modification on the TS-850S to be able to hear the receiving station through the loudspeaker and the headphones at the same time.

On ICOM rigs it does not require any modification at all as this is a feature built-in from the factory.
On ICOM rigs if you push the connector halfway into the headphone jack you have the sound in both the loudspeaker and the headphones, then if you push the plug the whole way in, the sound is only in the headphones.

Unfortunately this is not the case on the TS-850S.

The headphone jack is a little different made on Kenwood rigs, so this modification does not allow you this "halfway" feature described above. But still you are able to have the sound coming from the loudspeaker and the headphones at the same time.

Modification.

Note!

This modification works on both mono and stereo headphones.

1. Remove all knobs at the front of the radio.
2. Remove the front.
3. Remove the very small unit (E/6 page 57) that contains the phone jack itself.
4. Install a jumper between pin no. 1 and pin no. 2 on the CN8 connector.

This modification is read 1723 times.

[top of page](#)

19-07-1998

(TS-850) TS-850 and Ten-Tec Titan 425 PA

If you're using the Kenwood TS-850S with the Ten-Tec Titan 425 linear PA read this!

This explains how to modify the TS-850S' full QSK feature and avoiding "hot switching" the relay in the amplifier when operating full QSK.

As you probably know the correct way to prevent "hot switching" is to feed a signal to the Titan's "key-in" connector when you transmit. When the linear's vacuum-relay is settled the Titan's "key-out" connector return that information to the transceiver which then feed its output RF to the linear.

What's important here is that the transceiver DOES NOT feed any RF BEFORE the vacuum-relay in the linear is settled! (If you do, you have the problem called "hot switching")

This is how to overcome the "hot switching" problem:

Open the TS-850 and do the following:

1. Remove the original TRX-relay (K3 at the RF unit).
2. Remove the IF unit.
3. Locate the BK-SW unit (X59-3880-00).

Cut between Q2's collector and pin 10 on the BK-SW unit.

Feed Q2's collector to the "key-in" on the Titan linear.

Feed pin 10 (where you cut) on the BK-SW unit to the "key-out" on the Titan linear.

4. Reinstall the IF-unit.

That's all!

I connected the collector of Q2 to pin #4 on the REMOTE connector and pin #10 on the BK-SW unit to pin #2 on the REMOTE connector at the rear of the transceiver where you originally connect the keying of an amplifier.

That's why you should remove the TRX-relay (K3) as described in point no. 1.

Pin 4 on the remote connector should now be connected to the "key-in" on the Titan amplifier

Pin 2 on the remote connector should now be connected to the "key-out" on the Titan linear.

ONLY use shielded cables!!!

This modification works fine on my TS-850. I am able to operate full QSK at the maximum speed on the built-in keyer unit without risking any damage to the vacuum-relay in the Titan at full output power (1600W).

This modification is read 1598 times.

[top of page](#)

19-07-1998

(TS-850) KAM-PLUS Problems!! with TS-450 & 850

Hello All,,

A common problem when using a KAM-Plus multimode with the Kenwood TS-850 or TS-450 occurs when the KAM-Plus is coupled to the Accessory-2 socket on the back of the transceiver, producing noticeable distortion of the transmitted audio when using the microphone in SSB mode..

The problem is easy to cure by disconnecting the Accessory-2 plug from the back of the transceiver, but this meant moving the transceiver around every time one wished to operate on SSB..

The problem is caused by the input sensitivity of the rear Accessory-2 socket being set to high, so that it picks up very low level noise from the KAM-Plus and associated computer wiring, this mixes with the microphone signal, to produce the distortion.

The cure is to reduce the input sensitivity of the radio, thus reducing the chance of distortion, also it goes without saying that the output from the KAM-Plus must be increased to compensate for this.

With both the TS-450 and TS-850, adjusting the input sensitivity is straight forward and the transceiver manuals show you the appropriate control and its location.. This is in both cases VR18 to be found on the main board of the radio, (refer to manual) in practice I found that it was best to adjust this control fully counterclockwise..

Then we need to adjust the output from the KAM-Plus by varying potentiometer R28 and setting removable link (K9), this link is factory set on one post only, (in the open position)!! this should be connected shorting the two posts, thus putting the KAM-Plus into the high output position, and then potentiometer R-28 is adjusted to give full power out from your HF radio with very little ALC deflection, when the MIC gain is in the normal operating position..

Then I am sure you will find that your problem is over, you can now simply change from digital modes to SSB.. Remember if you have your Beacon activated to turn it OFF or it could cause a few comments when operating SSB..

This modification is read 1558 times.

[top of page](#)

19-07-1998

(TS-850) TS-450,TS-850 feedback,ACC-2 Conn

Hi if you are using the ACC-2 connector to interface with your multi-mode controller, you may have had a problem with your transmitted audio signal being distorted, to eliminate this see bellow.

1. Set your meter on the radio to read ALC
2. PK232 OWNERS: if also using a VHF transceiver, adjust the AFSK level for proper VHF operation as explained in chapter 3 of the operating manual. If not adjust for proper SSB operation.

DSP - 1232 / DSP - 2232 Owners: Adjust the appropriate AFSK level control for proper SSB operation as explained in chapter 3 of the operating manual.

3. Place the TNC in calibrate mode and press K to key the radio.
4. Adjust VR-13 on the TS-450 or VR-18 on the TS-850 so that the meter "Just comes off the peg" as described in the section titled "SSB Tranciever Final Adjustments" (in the TNC operating manual).
5. Press Q to quit the CALIBRATE mode

This modification should not affect any of the other normal operations of the radio..

Copy of service bulletin from AEA

This modification is read 1612 times.

[top of page](#)

31-03-1999

(TS-850) Modification for External keying, while using the internal keyer

Author: N7EX (ex-N0DH), Dave Henderson

One of the minor draw backs to the TS-850 as a CW contest machine is the inability to use the internal keyer in conjunction with an external keying circuit such as a personal computer or auxiliary memory keyer. As designed you must manually throw a switch from internal to external keying to switch between one or the other. To make matters even more inconvenient this switch is on the back of the unit and is not readily accessible during normal operation.

Simply said this modification involves running a new keying line from the junction of S1 and D51 on the IF Board. For convenience this additional keying line can be wired to the DSP1 and/or DSP2 RCA phono jacks if you do not use the external DSP unit.

The modification to the unit to resolve this problem takes less than 30 minutes to accomplish and can be done without "permanently" modifying the unit which would detract from its future resale value. If you don't use the external DSP unit then the two RCA phono jacks marked DSP1 and DSP2 can be used as additional keying input jacks as will be outlined below. If you use the external DSP unit then the modification can still be accomplished by running the external keying line out on a "pigtail." I highly recommend the purchase of a service manual which will greatly improve your ability to indentify the circuit points involved in the modification.

Considering that the radio costs \$1500 what's another \$30 to keep from messing it up! By the way compared to the two TS-930's that I nursed through the 80's, this radio is a breeze to trouble shoot and repair which I have had to do twice through no fault of Kenwood (long stupid story ~8>).

From here you proceed at your own risk, if you fry the radio DON'T CALL ME. A precision low wattage solder pencil for doing surface mount soldering is recommended, If all you have is a 150 watt Weller solder gun then read no farther your better off taking the unit to an expert rather than "melt" the circuit traces.

I assume no risk for the accuracy or completeness of the enclosed information. All yee who enter here embrace all hope for you may likely have a better contest radio when you are done.

1. Turn the unit upside down with the back of the TS-850 toward you.
2. Remove the bottom cover.
3. In this position the IF board is on your left.
4. Remove all the screws holding the IF board to the chassis.
(put them in a jar or something for safe keeping).
5. Unplug enough of the cabling to allow you to tilt the board up so that you can access the bottom side of the board underneath S1 the "External/Internal" keying switch.
6. On the bottom side of the board directly underneath S1 you will see 6 solder pads arranged in two rows of three pads each.
7. The middle pad on S1 nearest the back of the radio should be GROUND, solder the braid of an approximately 9 inch piece of small audio style shielded cable to this point, being careful to dress the coax so as not to short to other circuitry.
8. The middle pad on S1 in the next row up of three pads is the keying line. Solder the center of the shielded cable to this point.

9. Route the other end of the shielded audio cable through the chassis in the vicinity of the DSP jacks above.
10. Carefully inspect all solder joints for shorts, etc. Replug the wire harnesses unplugged in step 5 above and reassemble the board to housing. Reassemble the bottom cover.
11. Turn the unit over and remove the top cover.
12. Find the DSP input board with the three RCA phono jacks on it at the rear of the unit. The two DSP jacks are on the right when facing the rear of the unit. There are two connectors on this board (a 2pin and a 4pin). Unplug the 4 pin connector. Obtain another 4 pin connector and connect as follows (or directly solder to the underside of the board as follows) If you only need one additional CW jack then ground is pin 2 (closer to center of the radio) connect the braid of your new key line to this pin. The input from the middle RCA phono plug is pin 1 connect the center conductor to this pin. Likewise if you want two additional CW jacks then do as above plus add a short between pins 1 and 3. If you want a small RF choke or some ferrite beads on the center conductor of the audio cable may prevent keying problems in high RF field environments...
13. Close the unit up and switch S1 to INTERNAL keying. You should now be able to key the unit via the internal keyer (Via the standard key input jack) or with an external keyer or computer via the old DSP jacks, without having to switch S1.

This modification is read 1534 times.

[top of page](#)

31-03-1999

(TS-850) TS-850 Separate Receive Antenna Modification

Author: Brian, WA3WJD

Make a short loop of white teflon cable with a male and female BNC connector.

Loop it out of the back of the rig so just enough of the coax sticks out so the BNCs can be joined with a barrel connector.

Locate the little header connector on the filter board in the TS-850 that is on the receiver side of the TS850 antenna relay. Pull that connector loose.

Spend a little time tracking down male and female header connectors that match what Kenwood uses. Install those on the ends of the white teflon coaxes sticking in the back of the radio.

For normal use, just connect the BNCs with a barrel connector and the rig is normal. For Beverage use, connect an extra antenna switch common and ant #1 to the BNC connectors, and put ur Beverages on the other positions.

This modification is read 1679 times.

[top of page](#)

31-03-1999

(TS-850) TS-850 Separate RX antenna input mod

Author: N6TR - n6tr@teleport.com. MODIFICATION.NET

This is near the top of everyone's list when they are asked "What things bug you about the TS-850S." I initially overcame this deficiency by modifying my amplifier so I could connect a different receive antenna to the TR relay. However, I wanted to change things so there wasn't as much RF getting into the RX antenna due to close proximity to the amplifier's output. This became a problem when using the same receive antenna on a second radio (you knew two radio contest operating was going to work its way in here somehow).

Ville, OH2MM had provided me with instruction on how he modified his TS-850S to have a separate RX input and this inspired me to try it.

Here are some simple steps to hopefully inspire others:

It took me an unrushed two hours to do all this.

1. Remove the top panel (you don't need to take off the bottom one).
2. Remove the plate which sits between the fan and the back of the radio. This covers the output filter PC board.
3. Unsolder the connections to the SO-239 output connector.
4. Remove the three cables from the PC board next to the SO-239. This includes two coax and one 3 conductor harness.
5. Remove the two screws holding in the PC board and remove it.
6. Locate the trace that goes from the relay's normally closed contact. You can use an ohm-meter to find it - probe from the wire

that went to the SO-239. You will find a short trace on the back of the board which runs to a chip capacitor. Cut this trace and solder some very small coax to each side of the cut - connect ground to the nearby ground trace. Make the cables about 4 inches long.

7. Remove the antenna tuner. There are 2 screws in the back and front (you will need a magnetic screw-driver) and one on the side. You will need to carefully unplug two wire harnesses and one coax connector.
8. Drill two holes for phono jacks on the back of the radio. Be careful not to obstruct the screw hole for one of the screws in the back of the antenna tuner. The best place is between the RF output connector and the groundpost. Put them on top of each other and as close to the bump on the back panel as possible. I used a vacuum cleaner while drilling to make sure no metal chips went anywhere.
9. You will find a small hole under the SO-239 where you can feed the two coaxes through. Solder them to the phono jacks and reassemble everything. I put back to back diodes on the RX antennas input, but you may not want to do this. A better thing would be to add a relay to disconnect the RX antenna input when transmitting. I took care of that in project #2.
10. Obviously, you will need a jumper cable to make your receiver work again.

This modification is read 1545 times.

[top of page](#)

31-03-1999

(TS-850) The switch box

Parts list:

- 4 position rotary switch
- DPDT 12 VDC relay
- 1 K Ohm pot (optional)
- 12 phono jacks (or you can get by with 9)
- mini box for above and knobs.
- Clamp diode for relay coil if not included in relay

This box does two things: disconnects the receive antenna input when transmitting and allows selection of the transmitting antenna or one of three RX antennas when receiving. The pot can be used for RF attenuation if your rig doesn't have one.

The relay gets controlled by the PTT output from your rig that normally would go to your amplifier. Then one set of the contacts is used to key your amplifier. Don't forget to put a diode across the coil of your relay if there isn't one internally. Otherwise, you will have undesired arcing across the contacts of the relay in your radio.

The other set of contacts disconnect the output of the rotary switch when transmitting. The rotary switch selects either the signal coming from the transmitting antenna (from the TR relay in your rig) or one of three receiving antennas. I use two phono jacks per RX antenna so I can feed them to other boxes for other radios. I also use two jacks for +12 volts so I can jumper power to another box.

You can build up one of these boxes in an hour or two. You can epoxy the relay to the mini box.

If you want the pot there to act as an attenuator, I just hook it up like you would a volume control: one end is ground, the other end goes to the output of the rotary switch and the wiper goes to the output. Use shielded cable as much as possible to avoid stray pickup.

This modification is read 1631 times.

[top of page](#)

31-03-1999

(TS-850) Computer Interface for the TS-850, without using the IF-232 Level Converter

By N6TR and possibly others, with zener idea added by K6LL.

Note: This interface will work with "TR," contest logging software by N6TR.
Click here for links to TR and other contest logging software packages, including shareware.

Computer Interface:

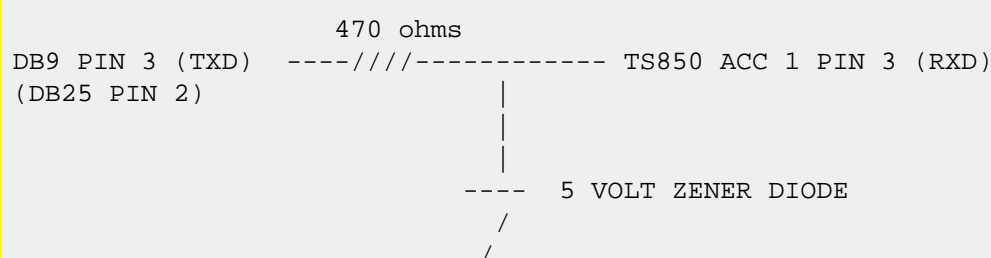

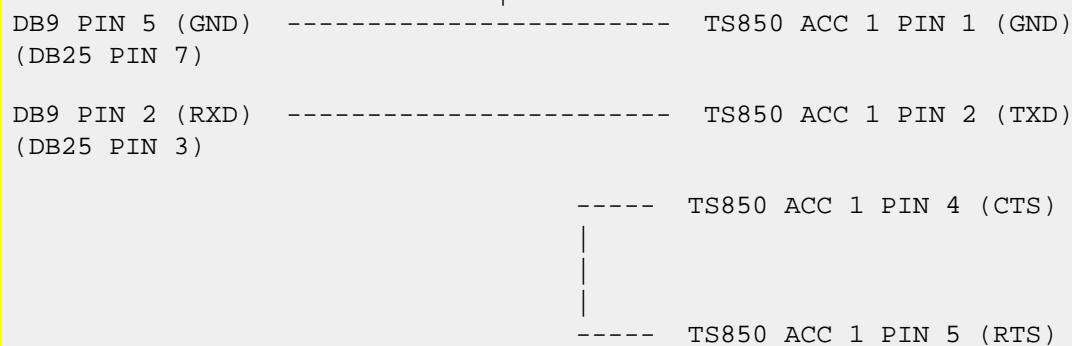

This modification is read 1633 times.

[top of page](#)

31-03-1999

(TS-850) TS-850 Power Output Control

VR7 on the RF Board (bottom side of radio). 125 watts or so on cw is safe. Do not exceed 100 watts on SSB, since distortion will broaden the transmitted signal.

This modification is read 1890 times.

[top of page](#)

31-03-1999

(TS-850) TS-850 Level Attenuator for DRU-2 playback audio

Author: K6LL - k6ll@juno.com. MODIFICATION.NET

1. Remove the little hatch on the top of the radio.
2. With the front of the radio facing you, find connector CN505. It is a five pin connector near the filter DIP switches. The white wire on the leftmost terminal carries the DRU audio output.
3. Cut the white wire and insert a 100K ohm micromini pot, shunted with a 220 pf capacitor. Adjust the pot until DRU playback level matches live microphone level.

Dave Hachadorian, K6LL

This modification is read 1332 times.

[top of page](#)

22-08-1999

(TS-850) TS850 + Transverter oder Preselektor

Author: Werner Maier, DL4NER - werner@mayn.de. MODIFICATION.NET

Wenn man von hinten auf den TS850 schaut, ist rechts eine komplette Leiste mit Steckern (ACC, diverse Cinch (ALC etc.)) usw. Oben sind zwei Reihen und unten ist noch eine dritte Reihe. (da ist auch die Cinch IF-Out dabei, die original (lt. Manual) benutzt werden sollte. Mir persönlich hat das mit den 12 Volt nicht gefallen; das Risiko für Transverter und Nachsetzer bei Ausfall der 12 Volt war mir zu groß!

Genau dazwischen (oben 2 Reihen, unten 1 Reihe) ist rechts ein Platz von ca. 2cm hoch, 8cm Breit und 3 cm tief. da passen die benötigten 4 Cinchbuchsen (drvout, drv in, ant out, ant in) problemlos hin.





Diese muß man für den normalen KW-Betrieb nur außen mit Cinch-Cinch-Koaxkabeln brücken. Da es sich um Kurzwelle (d.h. $f < 30\text{MHz}$) handelt, dürfte die auftretende Dämpfung vernachlässigbar sein.

Zudem gibt es dort in den Gehäuseverstreibungen IDEAL Platz zum Kabeldurchführen, als ob es von Kenwood dafür vorgesehen wäre und aus Marketinggründen zugunsten des TS950 gestorben wäre. So schauts jedenfalls für den Bastler aus. Oder der Platz wurde einfach präventiv für Stecker freigehalten... wer weiß...?

Vorgehensweise:

1. !!!!! OHNE GEWÄHR !!!!!
2. Boden und Deckel abnehmen.
3. von oben: Filterplatine (mitte) wegnehmen.
4. Gehäuserückseite abschrauben, PL-Buchse ablöten (evtl. sind hier mehr als zwei Hände hilfreich!)
5. Anzeichnen, bohren, auf genügend Abstand zwischen den Cinch-Buchsen und Gehäuseverstreibungen achten. (ca. 16 mm Lochabstand reicht, damit man sich die Finger nicht klemmt, beim Betrieb hinterher wie z.B. Stecker ziehen...) Beschriften mit z.B. ANT out, IF in, DRV out, FINAL in (oder wie's beliebt).
6. Kabel auftrennen: von der IF-Platine (wenn das Gerät umgedreht wurde, vorne links) gehen ziemlich hinten an den Steckverbindungen nach hinten mitte unten zwei Kabel weg, CN1 und CN2 (weiss und Rot/Orange/Rostbraun). Die beiden Kabel sind im Bild zusätzlich mit einem gelben beschrifteten Klebeband gekennzeichnet.
7. Das eine führt direkt zur Antennenumschaltplatine, wo auch die PL- Buchse angelötet ist. Auftrennen, Verlängern und auf 2 der Cinchs legen. Das zweite führt direkt zur Final-Unit (unter der Filterplatine). Auftrennen und auf die Cinchs führen.
8. sind die Buchsen hinten RICHTIG beschriftet? und RICHTIG verbunden? Besser mehrfach prüfen, das Teil ist teuer! Ist die Beschriftung eindeutig?
9. Zusammenbauen. Dabei ALLE Steckverbinder wieder stecken. Mögliche Fallstricke sind vielleicht:
 - **Verbindung Final-Unit-out -> Filter-Unit-in ?** (muss gelöst werden, um die Filterunit auszubauen).
 - **PL-Buchse wieder angelötet ?**
 - Lautsprecher wieder angesteckt ?
10. Hinten brücken und als KW-TRX testen. Preselektor anstöpseln, testen. Transverter anstöpseln, testen.
11. !!!!! OHNE GEWAEHR !!!!!



Das Schöne ist nun, daß man problemlos einen Preselektor dazwischenschalten kann. Ebeneso problemlos geht das mit Transverter-Betrieb, ohne Angst um Transverter und TRX haben zu müssen, falls mal die 12V Steuerspannung vom Transverter ausfällt. (Lt. Aussagen eines Fachhändlers nimmt dabei nicht nur der Transverter sonder auch der TS-850 gewaltig Schaden.).

Und: Die Signale nach Außen unterscheiden sich von der Original-Kenwood- Schaltung (->Transverterbetrieb) nur dadurch, dass jeweils ein Relais weniger in der Kette liegt.

Signal	original	modifiziert	Vorteil	Nachteil
10m-RX	direkt zur Antennenbuchse	wird nach Antennenbuchse und RX/TX-Relais zugeführt.	Preselektor-Betrieb möglich.	Ueberspannungsdiode wird umgangen. (Gewitter im Transverter? Dann ist eh' alles zu spät!)
10m-DRV	wird vor CN1 mittels Relais auf CN25 geschaltet und von dort mittels im Gerät umzusteckender Brücke auf die IF-Out-Buchse gelegt, die dann nicht mehr für ZF-Oszi geeignet ist.	wird ohne Relais nach CN1 direkt aufgetrennt.	1. Man muss nicht mehr mit 12 V schalten. 2. Wenn die DRV-Leitung aufgetrennt ist, sendet die Endstufe auch nicht.	Löcher in der hinteren Abdeckung und ein "verbasteltes" Gerät.

Rückbau: (für Verkauf, falls gewünscht):

Löcher: Kenwood-Aufkleber.

Durchtrennte

Leitungen: Ersetzen durch originale Leitungen (gibts bestimmt für Geld bei Kenwood).

73 de Werner Maier, DL4NER email: werner@mayn.de.MODIFICATION.NET Viel Spaß mit Preselektor oder Transwerter.
Zugriffe Seit 9/97:

This modification is read 1406 times.

[top of page](#)

22-04-2000

(TS-850) TS-850S Distorted TX w/TNC connected

Author: Kenwood Communication, inc.

Service Bulletin no. 1000 (10 October 1992)

We have received several reports of distorted transmitter audio when using a TNC controller such as the AEA PK-232 or Kantronic KAM, etc. The symptom will generally disappear if the transceiver and TNC units are powered from different sources.

Cause:

The audio output level from the TNC is generally too high and causes overload of the microphone amplifier circuit. In previous models such as the TS-440S the incoming TNC audio was inserted after the microphone amplifier. With the TS-850S it is inserted before the microphone amplifier. Just moving the insertion point to the output of the circuit is satisfactory since the drive level for FM packet is higher than that required for SSB.

Procedure:

1. Add a 10 dB attenuator to the PKD line on the IF unit (X48-3080-XX). This will prevent overmodulation of the microphone input circuit.
 - a. Change chip resistor R258 from 2.2 Kohm to 1 Kohm (RK73FB2A102J)
 - b. Change chip resistor R260 from 220 to 330 ohms (RK73FB2A331J).
2. Add the following note to page 29 of the Instruction manual.
3. When adjusting for proper ALC levels with an AFSK RTTY terminal or Packet TNC terminal you should adjust VR-18 on the IF Unit for a reading similar to the one shown in the accompanying diagram.

Note: The transceiver and RTTY or TNC terminal should use separate power supplies, in order to prevent RFI (Radio Frequency Interference).

Caution: This modification requires soldering equipment rated for CMOS type circuits. It also requires familiarity with surface mount soldering techniques. If you do not have the proper equipment or knowledge do not attempt this modification yourself. Seek qualified assistance.

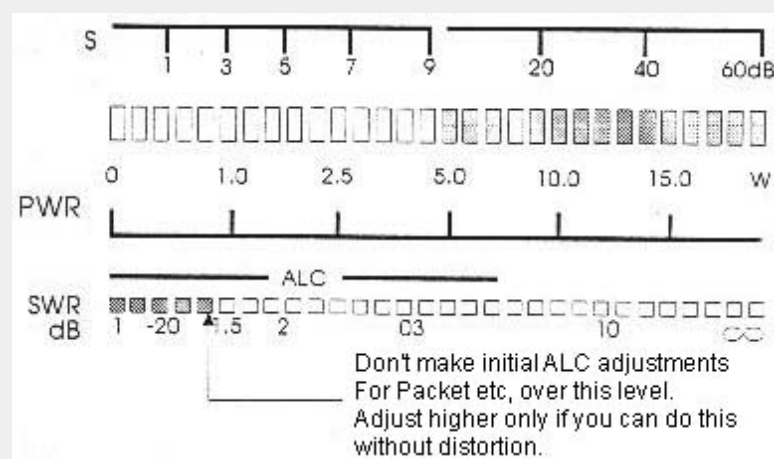

Time required for this modification is ½ hour or less.

This modification is read 1350 times.

[top of page](#)

22-04-2000

(TS-850) TS-850S Low/no Receive sensitivity

Author: Kenwood Communication, inc.

Service Bulletin no. 1006 (22 January 1993)

Symptom:

Reports of low or no receive sensitivity accompanied by a lack of audio from the speaker during CW or SSB modes might be caused by improper RXB voltage levels. Normal RXB voltage is +8 Vdc during receive and 0 Vdc during transmit. If you find approximately +2 Vdc during receive you might suspect a problem with a leaking diode, D31 on the RF unit (X44-3120-00).

Cause:

D31 is used as the transmit switching diode. Leakage of this diode is most probably caused by electrostatic surge or discharges from the antenna.

Parts required:

D31, MI204

Procedure: A temporary cure for units that have already been manufactured is to replace D31 with an MI204 diode. Future production radios will change D31 to an LFB01 diode and incorporate a change in the printed circuit foil pattern to allow addition of a series diode, D103 (LFB01).

Caution: This modification requires soldering equipment rated for CMOS type circuits. It also requires familiarity with surface mount soldering techniques. If you do not have the proper equipment or knowledge do not attempt this modification yourself. Seek qualified assistance.

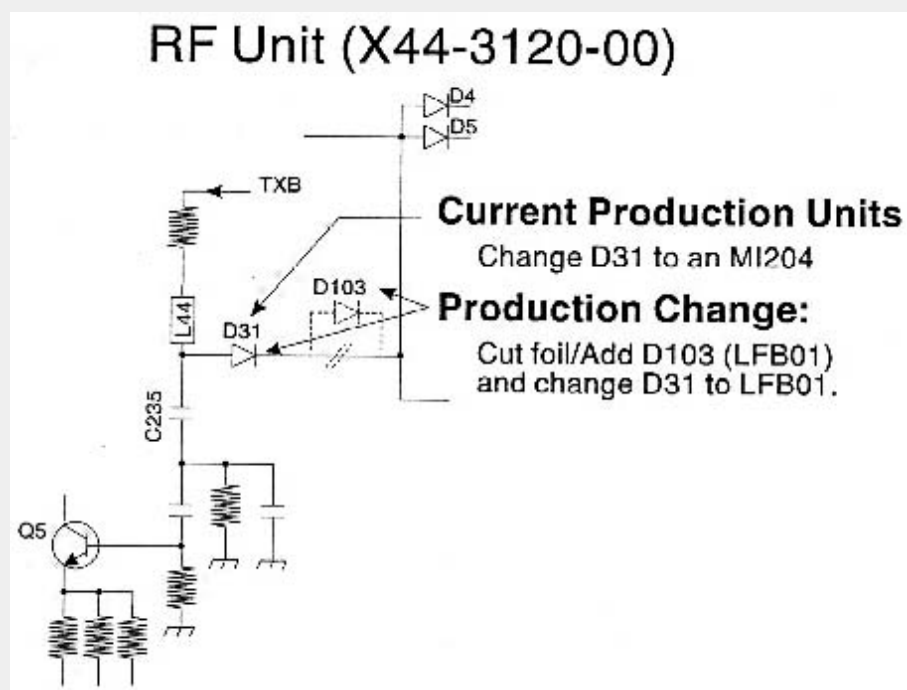

Time required for this modification is 15 minutes or less.

This modification is read 1475 times.

[top of page](#)

23-04-2000

(TS-850) TS-850S No audio from VS-2

Author: Kenwood Communication, inc.

Service Bulletin no. 1034 (6 December 1993)

Symptom:

Several have reported a problem with the Voice Synthesizer Unit VS-2 not voicing the frequency reliably when the Voice button is depressed. This symptom is caused by a drop in the 5C voltage from 5 Vdc to approximately 4.5 Vdc when the VS-2 is connected. The following change will correct this symptom.

Parts required:

Qty	Description	Old part No.	New Part No	Circuit desc.
1	47 μ H Chip coil	L40-221-48	L40-4701-48	L501

Procedure:

Change L501 from 220 μ H to 47 μ H on the RF unit (X44-3120-00 C/4).

Caution: This modification requires soldering equipment rated for CMOS type circuits. It also requires familiarity with surface mount soldering techniques. If you do not have the proper equipment or knowledge do not attempt this modification yourself. Seek qualified assistance from your closest Kenwood Service Center (Long Beach, CA, or Virginia Beach, VA).

Time required for this modification is 30 minutes or less.

This modification is read 1308 times.

[top of page](#)

23-04-2000

(TS-850) TS-850S Mixer FET change

Author: Kenwood Communication, inc.

Service Bulletin no. 1046 (28 March 1994)

Symptom:

Several units were discovered during production by our QC department that experienced difficult when the transceiver was being adjusted for an S-1 reading on the S-meter.

Countermeasure:

Variations in the gain of the devices used for Q16 and Q17, the second mixers, on the RF unit (X44-3120-00) appear to cause of this symptom. We, therefore, recommend replacing these two transistors with 2SK520(K43) devices. These devices have lower IDSS (Drain breakdown current), and therefore provide a greater conversion gain. As a result the total gain of the circuit is increased.

Parts required:

Qty	Description	Old part No.	New Part No	Circuit Description
2	Second Mixer FET	2SK520(K44)	2SK529(K43)	Q16, Q17

Time required for this modification is 60 minutes or less.

This modification is read 1520 times.

[top of page](#)

23-04-2000

(TS-850) TS-850S "Click noise" with NOTCH ON

Author: Kenwood Communication, inc.

Service Bulletin no. 1049 (28 March 1994)

Symptom:

When a strong signal of S-9 or greater is received at the antenna terminal with the NOTCH circuit ON a "clicking" noise might be noticed. This is caused by excessive response in the AGC loop circuit.

Countermeasure:

The changes detailed below will add additional delay to the AGC circuit and reduce or eliminate this tendency.

Parts required:

Qty	Description	Old part No.	New Part No.	Circuit Description
1	22 Kohm chip resistor	RK73FB2A103J	RK73FB2A223J	R289
1	0.47 μ F capacitor	NA	CQ92M1H474K	NA

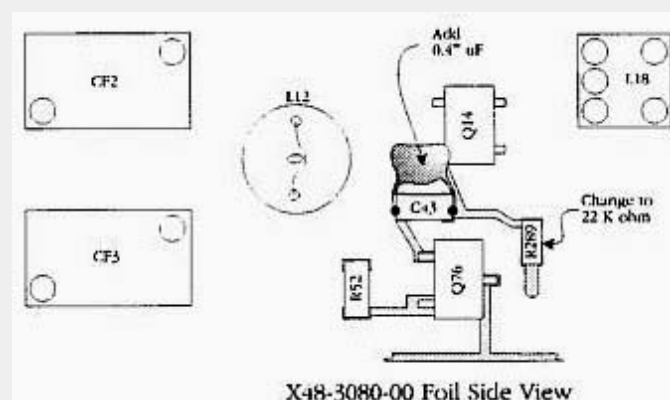

Caution: This modification requires soldering equipment rated for CMOS type circuits. It also requires familiarity with surface mount

soldering techniques. If you do not have the proper equipment or knowledge do not attempt this modification yourself. Seek qualified assistance from your closest Kenwood Service Center (Long Beach, CA, or Virginia Beach, VA).

Time required for this modification is 60 minutes or less.

This modification is read 1411 times.

[top of page](#)

14-06-2001

(TS-850) Full transmit for the UK version of TS-850S

Author: Pred - Q2_Kinani@btinternet.com.MODIFICATION.NET

This mod concerns only the UK kenwood TS-850S.

On the circuit board behind the front panel lies a bank of diodes numbered D1-D11 all diodes are there except for diode D10 to unlock the uk TS-850s to full transmit.

Just cut or remove diode D11.

Perform full cpu reset, when powering unit after modification for full reset press and hold A=B while turning on unit

Pred

This modification is read 1626 times.

[top of page](#)

24-07-2001

(TS-850) TS-850 2nd RX output mod

Author: Gary G4iFB - G4iFB@Amsat.org.MODIFICATION.NET

The rules for RSGB National Field Day allowed the use of a second receiver but (at least in Restricted Section) just one antenna. The second receiver could be used as a "spotter", for example to keep an ear on 28 MHz for sporadic openings, or to check whether there is sufficient activity on another band to justify a band-change.

In the absence of a top-of-the-range transceiver with a second receiver built-in, I was prompted to make following modification to my TS850 such that an external receiver could be connected to the single antenna, yet be disconnected automatically when the TS850 transmits.

The modification is described in detail step-by-step below, but first you will need the following items:

- a small length (about 20cm) of miniature coaxial cable, for example Maplin part number XR88V (note - the characteristic impedance of miniature coax is typically 75 ohm giving a mis-match to the 50 ohm impedance of the rig and antenna system, but such a small length of cable is required that there is no noticeable effect in practice)
- a coaxial "line" socket e.g. SO239, BNC or Belling-Lee (again, the impedance mismatch caused by using 75 ohm connectors has a negligible effect in practice);
- a fine-tipped soldering iron and multicore electrical solder;
- a medium (e.g. "number 2") cross-head (Phillips) screwdriver.

NOTE: a modification such as this is liable to void the manufacturer's warranty - proceed at your own risk. It also involves a fairly delicate soldering operation so DO NOT ATTEMPT THIS unless you are competent and confident at soldering.

1. Switch off the power and disconnect all external leads to the rig. Clear a space on the table in which to work.
2. Remove the rig's top cover:
 - a. Remove 11 cross-head screws (3 on each side, 2 front and rear on the top, and the last one centrally on the top panel - don't remove the 4 screws holding the loudspeaker to the top panel!). Keep the screws safely in a container to one side.
 - b. Carefully lift the top cover until you can reach the loudspeaker cable - remove this by pulling off the small white plastic plug from the socket mounted on the printed circuit board under the loudspeaker.
3. It is probably easiest to turn the radio so the rear panel is towards you. Remove the metal lid from the TX output bandpass filter unit in the middle at the rear of the TS850, with a black rubber section attached (which normally insulates it mechanically from the top panel). There are 7 cross-head screws to remove.
4. Find the small printed circuit board immediately behind the rig's SO239 antenna connector. The black rectangular relay on this

board is the main TX/RX changeover relay. Remove this board from the radio:

- a. Carefully disconnect the two coaxial cables by pulling out the miniature pushfit plugs from the board-mounted sockets, and pull out the white plastic plug connecting the control wires to the board.
 - b. Remove both mounting screws.
 - c. Unsolder the SO239 socket from the board - both inner and outer connectors need to be unsoldered - and lift out the board.
5. This is the fiddliest part of the job - get help now if you are not confident at soldering. Solder your short piece of miniature coax to the underside of the TX/RX relay board, in parallel with the TS850 receiver output connector labelled "RAT CN6". The coax should preferably exit to the rear of the board so that it will pass directly through the TS850 rear panel when reassembled. The coax centre conductor should be soldered to the "RAT CN6" pin nearest to the small coil labelled "L13", and the braid to the adjacent (centre) "RAT CN6" pin which is earthed. Check carefully that the joints are good (shiny and clean), and that no solder blobs or flakes remain on the board.
 6. Pass the free end of the new piece of miniature coax out through the gauze on the rear panel of the TS850 - you may need to enlarge a hole in the gauze slightly, but the coax should be a fairly tight fit.
 7. Replace the TX/RX relay board in the radio, pulling the miniature coax through the rear panel as you do so. Reconnect the board by reversing the instructions given in section 4 above - connect all three leads (two coax leads, one 3-wire lead - the plug is polarised such that it is only possible to connect it one way, namely with the red lead towards the 1k ohm vertical resistor) and don't forget to solder the SO239 back on to the board. Once again check that your solder joints are good and no wayward blobs of solder remain.
 8. Replace the TX output bandpass filter unit cover and its 7 screws.
 9. Replace the rig's top cover, not forgetting to reconnect the loudspeaker lead to connector "CN507" on the small circuit board connected to the front panel by a white ribbon cable as you do so. Take care not to scratch the paint when replacing all 11 screws.
 10. Fit the coaxial socket to the free end of the miniature coax.
 11. Check the results. Reconnect the rig and turn it on. Confirm that it receives properly. Try transmitting briefly to check that the RF output level is normal.
 12. Connect an external receiver using a coax patch lead between the new socket and the antenna socket on the receiver - NOTE: be especially careful if using a transceiver as the external receiver that the second rig cannot transmit. Preferably, disable the transmitter completely. RF POWER ABOVE A FEW MILLIWATTS ACCIDENTALLY APPLIED TO THE EXTERNAL RECEIVER CONNECTOR WILL INSTANTLY BLOW THE TS850'S RX INPUT CIRCUITRY AS THERE IS NO PROTECTION IN CIRCUIT!!!

Well, that's it. Mod complete. Now all you have to do is figure out how to make use of two simultaneous receiver signals without getting totally confused! By the way, although the external receiver's antenna is automatically disconnected when the TS850 transmits, there will still be plenty of RF in the vicinity - it is probably best to avoid tuning the external receiver to the TS850's transmit frequency, possibly even the same band, or to use an external band-pass filter in the receive line.

Best of luck in the contest OM! 73 de Gary, G4iFB

This mod is a copi from www.g4ifb.com/TS850_mod/ts850_mod.htm with permission from G4iFB.

This modification is read 1772 times.

[top of page](#)

19-07-1998

(TS-870) Frequency expansion for the TS-870S

From: Howard Ryder - W4NTW@ix.netcom.com

Here is your chance to prove how adept you are at microsurgery. This mod will enable the TS-870S to transmit on MARS, CAP and othe frequencies.

1. Remove top and bottom covers.
2. Remove the top screw from each side of the front panel assembly.
3. Carefully rotate the front panel forward to gain access to the control board(x53-3560-11 a/4). This board is mounted vertically against the body of the transceiver. It is not the board that is mounted in the front panel assembly.
4. Locate and remove resistor R244 from the control board. R244 is below IC12 ROM and above IC23. There are two chip resistors, one on top of the other -carefully remove or break the top one..it is easily fractured -that's R244.
5. 5. Reassemble and then perform the cpu reset by holding the A=B button depressed as power is turned on.

19-07-1998**(TS-870) TS870 DSP XCVR specs**

Kenwood have just introduced their new HF Transceiver, the TS870 which replaces the TS850s and TS850sat.

By far the greatest change is that the new radio has a fully digital signal path. All filtering, both in terms of width and noise reduction, is achieved digitally, so there are no optional analogue filters!

Also built in as standard are a K1 logikeyer for the dedicated cw operator, an auto atn which covers both tx and rx, plus an RS-232 adaptor internally.

Kenwood may also be able to supply a windows based control program in the near future.

TS 870S SPECIFICATION.

By applying the best of it's DSP technology, Kenwood has succeeded in developing the TS870S, a new generation of HF SSB transceiver that offers superior digital interference reduction as well as receiver performance of a quality hitherto impossible using the conventional analogue circuitry.

New HF transceivers based on this design concept are collectively called the "Intelligent Enhanced Communications System". (AA1)

MAIN FEATURES:

HF DSP for post-IF signal processing:

Digital RX Filters: The TS870s features post-IF digital filters for ALL modes - SSB,CW, AM, FSK and FM, a World first!! offering precise performance that is unobtainable with analogue circuits.

Bandwidth of the digital filters can be optimised in various working conditions. You are now also free from struggling to put in the optional IF filters, thanks to the new razor sharp digital filters.

SSB MODE:

Hi Cut: 1.4 - 6.00khz (12 steps)

Low cut: 0 - 1000hz (10 steps)

CW MODE:

VBT: 50 - 1000hz (6 steps)

SHIFT: 400 - 1000hz (13 steps)

FM MODE:

VBT: 5 - 14khz (6 steps)

AM MODE:

Hi Cut: 2.5 - 7khz (6 steps)

Low Cut: 0 - 500hz (4 steps)

FSK MODE:

VBT: 250 - 1500hz (4 steps)

NOISE REDUCTION:

The TS870S is capable of picking out a target signal that is buried in the noise. To accomplish this, it employs the line enhancer method for ssb mode and the SPAC method for cw mode.

BEAT CANCEL:

This cancels out the sort of multiple beat interference that can effect reception automatically, which is impossible for analogue circuits.

IF AUTO NOTCH:

This is a filter which, when beat interference is experienced, attenuates only the interfering signal. Should the frequency change, the filter adjusts automatically.

Thanks to the post-IF DSP, it offers more precise performance than previously possible.

SELECTABLE TX AUDIO QUALITY & Characteristics:

3 types of adjustments are possible:

TX ADJUSTMENT:

In SSB and AM Modes, the bandwidth of the bandpass filter can be controlled.

BAND DIVISION SPEECH PROCESSOR:

The speech processor can be adjusted seperately for low, medium and high ranges.

TX EQUALISERS:

Equipped with 3 equalisers, high boost, bass boost and comb filter, the TS870S allows the user to select the desired sound quality.

DSP SIGNAL DETECTION:

Thanks to DSP Technology, the quality of signal detection is better than possible with conventional transceivers, in terms of both low distortion and high sound quality.

ATU that works on both RX and TX!!!!

Special CW features:

4 Channel Memory in built.....based on the K1 Logikey*tm:

2 Key Connectors!

CW Pitch control between 400 & 1000hz in 50hz steps!

NEW DRU-3 DIGITAL RECORDING UNIT:

By adding the DRU-3 unit, up to 60 seconds of continuous digital recording is possible!

This modification is read 1584 times.

[top of page](#)

24-04-1999

(TS-870) TS-870S S-Meter pin with repeated RX/TX switching

Kenwood service buletin 10/11/1996

Symptom:

The transceiver must be in the SSB mode, processor turned on, and AGC set to Slow. Repeated switching between transmit and receive may cause the S-meter to pin full scale. At that time, the receiver will mute for a few seconds.

Cause:

Insufficient processing of the AGC circuit.

Solution:

Replace the three EPROMs on the TX-RX board with the new ones listed below.

TX-RX Board X57-4620-00 (2/2)

Ref.	Original P/N	New P/N
IC4	27C256PCJJTE	27C256PCJJTF
IC5	27C256PCJJUE	27C256PCJJUF
IC6	27C256PCJJVE	27C256PCJJVF

Procedure:

1. Remove the bottom cover of the TS-870S
2. Remove the shield that covers the TX-RX board which is located on the right side of the bottom of the transceiver.
3. Carefully remove IC4, IC5, & IC6 from their sockets and replace them with the new parts listed above.
4. reset the transceiver by holding the [A#B] key depressed as power is turned on.

Caution:

1. Make sure the pins of the new EPROMs are properly aligned before insertion. New EPROMs tend to have the pins spread aout wider than the socket. The pins can be beat in by pressing each side of the EPROM against a static free work surface.
2. Avoid touching the EPROM pins. Graps the device from the top and bottom epoxy body ands between thumb and forefinger.
3. Avoid inserting the EPROMa backwards.

Only perform this change on units received for service with the exact symphthon listed above.

Use service codes (8): 18(B): X57-4620(P): IC4(C):91 on WSR.

Time required for this alignments is 15 minutes.

This modification is read 1389 times.

[top of page](#)

24-04-1999

(TS-870) TS-870S Receiver circuit changes

Kenwood service bulletin

The following provides a more useable range of the RF attenuator by re-allocating stage gain at the first and third IF. This change allows the use of less front end attenuation, allowing you to hear the desired signal while reducing interfering signals during CW contests and pile ups.

Caution:

This change requires advance surface mount soldering equipment that is rated for CMOS circuits. It also requires familiarity with advanced surface mount soldering techniques. If you do not have the proper equipment or knowledge, seek qualified assistance.

Required Parts:

RF PCB:

R157	1,8K	to	560	RK73FB2A561J
R160,161	2,2K	to	1K	RK73FB2A102J
R164	1.5K	to	560	RK73FB2A561J
R169	1K	to	330	RK73FB2A331J
L76,79	3.3u	to	0	R92-0670-05

TX-RX PCB:

R332	2.2K	to	6.8K	RK73FB2A682J
C340	.022u	to	.01u	CK73GB1C104K
VR1	470	to	3.3K	R12-6737-05 (optimal)

Procedure:

1. Remove the bottom cover and shields enclosing the RF board and TX-RX board.
2. Replace L76 and L79 on the component side of the RF board.
3. Replace C340 and R332 on the component side of the TX-RX board.
4. Access the bottom side of the RF board and replace R157, 160, 161, 164 and 169.
5. Perform S-Meter alignment step 8, on page 95 of the Service Manual. If you cannot obtain "05" of the display, replace VR1 on the TX-RX board with the part listed above.

NOTE:

With the exception of C340, this change was incorporated into production from S/N 801XXXXX, C340 was changed at S/N 807XXXXX.

Time required to perform this change is 1 hour or less.

Some [illustration](#).

This modification is read 1601 times.

[top of page](#)

09-10-1999

(TS-870) Making super radio out of TS-870

Author: Yuri Blanarovich, K3BU, VE3BMV, VE1BY, P - K3BU@aol.com. MODIFICATION.NET

I loved the TS-870 when I first got it. Size is ideal for expedition radio, light weight, fits in carry on luggage. Features and computer controls are excellent, until I used it in the contest on 160m. Bloody thing got overloaded with signals 4 kHz away. Everybody was QRMing me! What a piece of blinking junk! Liking the radio otherwise I inquired at Kenwood about the problem of overload. They came up with modification to remedy the gain distribution in the RF and mixer stages, which was implemented in later production models. After I received the service manual, I started to dig into the radio and came up with few more improvements.

Earlier production units before S/N 801xxxxx had problem with front end overload and consequent distortion and crossmodulation in the later stages, including DSP, especially noticeable on low bands. To remedy that on those earlier units see the Overload Modification.

There is an absence of 2nd RX antenna switching (Beverages, etc.). When I inquired at Kenwood, they supplied modification instructions that required some drastic modifications, including cutting the traces. When I obtained service manual, I figured very elegant modification using just plug in diode. See 2nd RX Antenna Switching modification.

Examining the circuits and filtering arrangement, I have found that Kenwood engineers decided to rely on obtaining the selectivity

mainly by using the DSP. Theoretically it is great, except when strong signals blow by the mediocre crystal filters used in stock TS-870, they modulate the following stages, including DSP circuits. The biggest improvement that puts this radio one class higher, is to replace the stock 2nd IF crystal filter and 3rd IF monolithic ceramic filter with high quality International Radio or other filters. Any better shaped filters make tremendous improvement to the selectivity, overload and DSP performance. Depending on intended use, you can use 2.7, 2.4 or 2.1 kHz bandwidth filters. I chose 2.1 mainly for contesting purposes. It is possible to use narrower filters for CW operation, but selectivity selection scheme via microprocessor controlled switching makes it complicated and throws the controls off their markings. I found that 2.1 filters work very well even for CW and are significant improvement over stock arrangement. See Filter Modification.

Overload Modification

NOTE: the changes do not apply to radios with S/N 801xxxxx and later.

Problem:

If there is any strong signal in the proximity on the low bands, it will cause crossmodulation and create a "ghost" signal. It may occur in the contest operation or during the pile-up reception.

Cause:

A larger power input signal causes the second mixer output, the NB amplifier input, the third IF amplifier input, and the third IF amplifier output to be saturated.

Remedy:

Change the gain allocation of the IF stage to raise the limit of saturation. This modification will cause almost no deterioration of receiver sensitivity.

Circuits from the antenna terminal onward:

Sequence is:

Antenna, amplifier, mixer, 73.05MHz filter

Amplifier, mixer, 8.83 MHz filter - noted gain is -10dB (minus 10)

Amplifier, mixer, 455kHz filter

Two Amplifiers - noted gain is +10dB (plus 10)

Replace the following components with (Kenwood part numbers)

Caution: they are all SMT chips, you need to be familiar with SMT soldering procedures.

Changes to circuit board XX4-3210 (A/9) RF UNIT

R1157 : replace 1.8k with 560 (RK73FB2A561J)

R160, R161: 2.2k with 1k (RK73FB2A102J)

R164 : 1.5k with 560 (RK73FB2A561J)

L76, L79 : 3.3uH with 0(zero) (R92-0670-05)

R169 : 1k with 330 (RK73FB2A331J)

X57-4620 TX-RX UNIT

R332 : replace 2.2k with 6.8k (RK73FB2A682J)

Adjustment:

Do not forget to perform the re-adjustment of the S-meter sensitivity after making the modifications.

Refer to "8. S-meter adj." on P.95 of the Service Manual for how to do it specifically.

If you cannot adjust the display to "05", even after you follow the steps described in "8. S-meter adj.", change the resistor as instructed below and make the re-adjustment.

X57-4620 TX-RX UNIT

VR-1 : 470 ---> 3.3k (R12-6737-05)

2nd RX Receive Antenna switching modification

Kenwood TS870 has two antenna jacks ANT1 and ANT2 and external receiver antenna jack (RCA type) that can accommodate external receiver when activated through the program menu. This adds some attenuation to TS870 receiver signals. There is no provision for external receive antenna switching (Beverages, preamp., etc.) When I inquired Kenwood about this option, they sent me modification instructions that required cutting the traces and rewiring the ext. RX connector. When I received my Service manual and had a look at the circuit, I came up with this simple modification:

Parts needed: 1 diode (any type) I used rectifier diode, generic NTE125

Step by step instructions:

1. (In the following references the front panel of the rig is facing you.)
Remove the top cover.
2. Remove 7 screws holding the cover over the FILTER and RELAY unit (in the middle) and remove the cover. (Where the ANT1 and ANT2 connectors go.) This exposes two PC boards.

3. Locate the connector CN301 on the RELAY unit (adjacent to ANT1 and ANT2). It is about 1 inch back and 1 inch left from the ANT1 connector and has three wires going to it - two gray, left and one black, right.
4. Take the diode, clip the leads to about 0.5 inch length, bend them down and form them so they are spaced about 1/8" and parallel (kinda forming letter Y).
5. Plug the diode into CN301 connector from the top, pushing the diode wires between the plastic housing and the metal contacts of the connector. Cathode (the end with the band marking) of the diode should go to the middle contact (gray wire), the other end to the left contact (gray wire). Make sure that diode makes good contact with terminals of the connector. Black wire should be free.
6. That completes the modification. Replace the covers, do not pinch the wires going to the antenna tuner!

Operation:

Connect your transmit or main antenna to the ANT2 connector. Connect your receive antenna or preamp output to ANT1 connector. Now you can transmit only through ANT2 connector.

Front panel button ANT now allows you to select ANT2 (receive/transmit on ANT2) or ANT1 (receive on ANT1, transmit on ANT2). Antenna tuner would always see the impedance on ANT2. The way the switching works, whenever you transmit, you will switch ANT2 on transmit, regardless of ANT1 or ANT2 selection. Much better use of connectors than originally devised by Kenwood

Notes on TS870 usage: Normally there is enough gain on the receiver for beverages. In case that you need to use the preamp or preselector, than turn the AIP on TS870 on, and if needed add the attenuators. Try to keep the noise level peaks close to low end of the Smeter scale. Helps with intermods. If using DSP, play with different settings and different levels of AGC setting, it has effect on overall behavior.

Filter Modification.

Major improvement in selectivity and DSP performance can be achieved by replacement of 2nd and 3rd IF filters with sharp crystal filters, like from International Radio. The 2nd IF 8.83 kHz filter used in TS870 is the stock Kenwood crystal filter, while the 3rd IF 455 kHz filter is little ceramic Murata filter.

I have ordered set of 2.1 kHz filters (8.83 and 455) from IR. The modification involves removal of printed circuit boards where the filters are located, unsoldering the old filters. In their place solder short piece of miniature coax to connect new IR filters. IR filters can be mounted between the circuit boards and the metal chassis using double sided sticky tape. Coax from old filter connections is then connected to new filters. Tweaking the matching IF transformers next to the filters ensures proper match and gain.

Other filters with wider bandwidth can be used also. For contesting I found 2.1 filters to be the best and the mod works very well on CW also. Selectivity improves as well as functions of DSP. Now it is a decent radio, matching those costing thousand(s) more.

Good luck and I am not responsible for any goofups you make! :-)

This modification is read 2027 times.

[top of page](#)

30-12-1999

(TS-870) Kenwood TS870S - ALC-Mod.

When I got the TS870S first I was really not amazed about the selectivity, also not about the quality of the build-in front end. But the filter-mod and also Kenwood \$B!- (Bs front-end-mod helped to solve these problems. But there was one additional possibility to improve something. When I reduced the output power to drive a bigger linear, I found, that the ratio is changing between SSB in comparison to modulate with a single-tone. If the percentage was 50% between voice and CW using 100W output before, the ratio is dropping down if you are running only 10W (measured with a peak-meter).

That is not very helpful, because it \$B!- (Bs not easy to drive the linear correctly in that case. And you can \$B!- (Bt improve that using higher microphone gain or processor. The reason is Kenwoods ALC-circuit (it \$B!- (Bs similar to the TS50S) which can be found on the RF-unit. In the circuit diagram it \$B!- (Bs named "Reserve Current Prevention". This part is directly controlling the TX-amplifier Q39. And this part has normally nothing to do with the power adjustment or regulation. But using lower output it \$B!- (Bs more sensitive and therefor more effective.

Modification:

Turn your TS870 on it \$B!- (Bs head (foots up) and remove the cover. If the display is looking into your direction, the big circuit board on the left-hand-side (underneath an additional metallic shielding) is the RF-board. Remove all connections carefully and afterwards the complete board. There are 3 electrolyte capacitors named: C286, C287, C289. Place a small resistor (I used a small chip-resistor) with 1 KOhm in parallel to C289, which is in the middle. Best is to do that on the soldering side (not component side). That \$B!- (Bs it ! Bring the TS870 back to live and afterwards you will see the improvment in SSB-mode and you can easily measure

it. Everyone told me afterwards, pumping effects are gone and my voice sounds fresh and clear (is that possible with an age of 40 ?) If you are only running your rig with full output, it \$B!- (Bs not necessary to realize this mod. In my case I am going down to 5 Watts - afterwards I \$B!- (Bm driving an attenuator going down to 20 mW (-24dB) and this is driving a commercial russian linear with the possibility of 2KW out (+50dB). Therefor it \$B!- (Bs absolutly necessary to have stable conditions.

Best Regards and good luck !

Andreas
DL6EAT

<http://www.apcc.com>

This modification is read 1541 times.

[top of page](#)

20-04-2000

(TS-870) TS-870 Output Power > 100W

Author: Werner - DJ2HZ / VE7HBI - wsz@ginko.de [MODIFICATION.NET](http://www.MODIFICATION.NET)

Many TS-870 TXCVR's generates output power less than 100 Watts.

There are output power setting procedures in the Service Adjustment Mode Menu.

In the adjustment mode there are 28 menu numbers A0 to BB (hex). All adjustments are saved in the EEPROM. When the service adjustment mode is entered, data is read from the EEPROM and placed in the CPU RAM so that settings can be modified.

The EEPROM is updated only when data is written in Menu No. bA (hex).

The Service Adjustment Mode Menu is a hidden menu.

OPERATION PROCEDURE

1. Connect a >100W 50 Ohms dummy load to the antenna terminal
2. Hold down the [N.R.] and [LSB/USB] key (together) and turn the [POWER] switch ON to enter the adjustment mode. The menu number will appear in M.CH on the display
3. When the 'M.CH/VFO.CH' control is turned the menu number changes. Turn the control knob to menu number 'A7' (100W Power adjustment)
4. Press the PTT key to transmit and while transmitting turn the 'RIT/XIT' knob to a desired power level (i.e. 120W). Don't use a power level > 140 Watts!
5. Press the [UP] key to confirm the new power level setting (don't forget it!).
The menu line should show two equal hex numbers. For example 120 W output power:
A7 b2 b2 PWR 100W. The second 'b2' is the local confirmation for your setting.
6. Turn the 'M.CH/VFO.CH' control knob to menu number 'bA'. The menu shows now:
ba rEADy EEPROM
7. Press the [UP] or [DOWN] key to store the new settings into the EEPROM.
8. Press finally the [CLR] key.

Note: When the [CLR] key is pressed before pressing the [UP] or [DOWN] key or power is switched OFF in the adjustment mode, all new settings are canceled.

Do not use a power level > 140w! your work is at your risk! i do accept no responsibility!

Good luck,

73, Werner
DJ2HZ / VE7HBI

<http://www.ginko.de/user/wsz/index.html>

This modification is read 2014 times.

[top of page](#)

07-05-2000

(TS-870) TS870 external receive antenna switching

Author: Yuri Blanarovich - K3BU - K3BU@aol.com. MODIFICATION.NET

Kenwood TS870 has two antenna jacks ANT1 and ANT2 and external receiver antenna jack (RCA type) that can accommodate external receiver when activated through the program menu. This adds some attenuation to TS870 receiver signals. There is no provision for external receive antenna switching (Beverages, preamp., etc.) When I inquired Kenwood about this option, they sent me modification instructions that required cutting the traces and rewiring the ext. RX connector. When I received my Service manual and had a look at the circuit, I came up with this simple modification:

Parts needed: 1 diode (any type) I used rectifier diode, generic NTE125

Step by step instructions:

1. (In the following references the front panel of the rig is facing you.)
Remove the top cover.
2. Remove 7 screws holding the cover over the FILTER and RELAY unit (in the middle) and remove the cover. (Where the ANT1 and ANT2 connectors go.) This exposes two PC boards.
3. Locate the connector CN301 on the RELAY unit (adjacent to ANT1 and ANT2).
It is about 1 inch back and 1 inch left from the ANT1 connector and has three wires going to it - two gray, left and one black, right.
4. Take the diode, clip the leads to about 0.5 inch length, bend them down and form them so they are spaced about 1/8" and parallel (kinda forming letter Y).
5. Plug the diode into CN301 connector from the top, pushing the diode wires between the plastic housing and the metal contact of the connector. Cathode (the end with the band marking) of the diode should go to the middle contact (gray wire), the other end to the left contact (gray wire). Make sure that diode makes good contact with terminals of the connector. Black wire should be free.
6. That completes the modification. Replace the covers, do not pinch the wires going to the antenna tuner!

Operation:

Connect your transmit or main antenna to the ANT2 connector. Connect your receive antenna or preamp output to ANT1 connector. Now you can transmit only through ANT2 connector.

Front panel button ANT now allows you to select ANT2 (receive/transmit on ANT2) or ANT1 (receive on ANT1, transmit on ANT2). Antenna tuner would always see the impedance on ANT2. The way the switching works, whenever you transmit, you will switch ANT2 on transmit, regardless of ANT1 or ANT2 selection. Much better use of connectors than originally devised by "knowitalls" at K...d.

Notes on TS870 usage: Normally there is enough gain on the receiver for beverages. In case that you need to use the preamp or preselector, then turn the AIP on TS870 on, and if needed add the attenuators. Try to keep the noise level peaks close to low end of the S-meter scale. Helps with intermods. If using DSP, play with different settings and different levels of AGC setting, it has effect on overall behavior.

TS870 looks like great contestpedition radio, it's light, fits in carry on luggage. I got speech module for phone CQing and small switching PS for it (\$160). I still miss the tunable audio peak filter and ability to go lower than 400 Hz on CW note.

Good luck and I am not responsible for any goofups you make!

Yuri Blanarovich,
K3BU, VE3BMV, P40A, one of N2EE
K3BU@AOL.COM

This modification is read 1376 times.

[top of page](#)

07-05-2000

(TS-870) [CQ-Contest] Collins Filters in Contest Rigs

Date: Tue, 11 Aug 1998

In a message dated 98-08-11 11:27:17 EDT, K2AV writes:

```
<< The Collins filters vary quite a bit. In the ft1000mp, the Collins 500
  hz filter (455 if) and (the CW soldered in) Yaesu 500 (8m if) cascaded
  are significantly less selective and less deeply skirted than the INRAD
  400 hz filters for both IF's cascaded. If you want to hear the
  difference, let me know and we can arrange a telephone call, and I can
  let you *listen* to the difference.
```

```
  In the 160 meter cw test I got between stations up & down 500 hz that
  are 20 over s9, and the INRAD cascade renders them *inaudible* unless
  they have key clicks. The difference after I switched was stunning. Hard
  to believe, but I am afraid that some of these new Collins filters seem
  quite inferior to the Collins of old.
```

```
>>
```

Same experience here, I tried Collins and Inrad filters in TS870 and Inrad filters seem to work better. One difference is 400 vs. 500 bandwidth and it also appears that design and packaging has changed. I was surprised by the small size of late Collins filters. Maybe technology advanced and shrank the components. The only way to test or compare is to do some plotting of the bandpass curve for various filters in your radio and do some comparison.

In TS870 the DSP seems to skew the results, it contributes to the shape of filter curve - DSP seems to "improve" it and mask the true bandpass. The best thing is to measure the signal after the filter's IF buffer stage, before detectors and DSP stages. (Or use the network analyzer for those who have access.)

Sometimes even the "same" filters have different characteristics, manufacturing tolerances can play games here.

The best CW filter I have seen so far is the Collins 300 Hz 455 kHz IF crystal filter. Amazingly it has less attenuation than wider Kenwood and Inrad filters and very sharp skirts.

When considering replacement/addition of filters one has to look at impedances too. In some cases buffer amplifiers or matching devices should be implemented and in case of cascading the same filters in particular IF, buffer amp might be needed to boost the insertion losses from additional filters. The most benefit is obtained from cascading sharp filters at the closest possible IF stage to the front end.

For the real rock crush proof front end there 50 ohm custom impedance filters available (INRAD) for custom design frequency. Great for those with their "own" CQing frequency. I haven't used them yet, but heard that some JA stations in metropolitan areas were using them.

Generally, if one wants to improve the receiver, the first thing should be to consider replacing the "stock" filters with better ones - gives the most bang for the money. Looks like some manufacturers are leaving this door open for upgrades by leaving enough room in the IF PC board stages area for extra and larger filters (Yaesu, Icom).

73 Yuri Blanarovich, K3BU, VE3BMV

This modification is read 1458 times.

[top of page](#)

07-05-2000

(TS-870) Use TS-870 as a contest rig

Author: Vladimir - ut1ia@qsl.net.[MODIFICATION.NET](http://www.modification.net)

Hello,

To whom who would like to use TS-870 as a contest rig, I would insistently recommend to make three proper mods, that I recently did (Geat TNX to Yuri K3BU/VE3BMV).

The first is intermod mod available from Kenwood for S/N below 801XXXXX.

This modification shifts gain distribution from RF stages to IF stages. Involves changing of about 8 resistors.

The second is filters mod. Yuri recommends to put two 2.1 KHz INRAD filter instead of two 3 KHz filters for both 8.83 and 455 IFs. I don't have INRAD fliters, so I replaced both (8.83 and 455) 3 KHz filters for another Kenwood filters 2.4 KHz: YK-88S-1 (the same size) and YG-455S-1 (needs much more free space and two coupling capacitors to avoid DC short circuit). These filters are quite good compromise due to the mixing and shifting scheme for various bandwidth. I plotted curve for original filter and new, the slopes were about the same due to DSP action. But there is a big difference in overload and intermod due to strong adjacent signals from edges of the filters. DSP is too late after the IF chain, strong signals outside of DSP bandpass but inside of filter bandpass will "pump" the stages ahead of DSP and "confuse" it. This is why good filters make huge difference.

The third is external receive antenna switching mod. After this mod : when "ANT2" is selected - Ant2 connector is for both TX and RX, when "ANT1" is selected - Ant2 connector is for TX only and Ant1 connector is for RX only, i.e. I can use another external antenna for

RX.

So, after all these mods done I estimate my rig's job like excellent.

73 Vladimir ("Bob") UT1IA
ut1ia@qsl.net.MODIFICATION.NET

This modification is read 1529 times.

[top of page](#)

19-10-2000

(TS-870) TS-870S Service Menu Setup Tweaking v1.1 (13 Oct 2000)

Author: John, CT2HME - joalopes@mail.telepac.pt.MODIFICATION.NET

Hello. My name is John, my call is CT2HME and I live in Lisbon, the capital of Portugal.

For some time now I own a Kenwood TS-870S. I have been playing around with the service menu on this rig for a while. The information on this menu is scarce and people are usually afraid to tweak this menu.

What you are about to read is practical information on the TS-870S service menu that may help you to take better advantage of this rig. Before start reading this information please note the following:

1. I don't work for Kenwood and they didn't gave me any information.
2. The information on this article **can** cause damage to your radio.
3. The information on this article **will** void the warranty of your rig.
4. Before your TS-870S leaves the factory, Kenwood has aligned your rig (I hope they also did that to mine!). If it's working properly **do not** tweak the service menu.
5. I will not be held responsible **in any way** for damage that you do to your TS-870S. Use this information **at your own risk**.

I'm sorry, but I had to say this.

Now, let's start.

The TS-870S service menu has 28 items. Each of this items has a function and each function will allow you to control different parts of your rig.

Each menu has a hexadecimal identification (from A0 to BB).

All this items are stored in a EEPROM that is read each time you turn on your TS-870S.

The service menu allows you to change the settings of this EEPROM by writing data on it.

The 28 items are the following:

A0 - System
A1 - ALC
A2, A3 and A4 - S-meter (SSB)
A5 and A6 - Filter
A7, A8, A9 and AA - Power Adjustment
AB, AC, AD, AE, AF, B0, B1, B2 and B3 - Tx Gain
B4, B5 and B6 - ALC meter
B7 - SWR Protection
B8 - SWR meter
BA - System
BB - Display

You can access the service menu on your TS-870S by doing this:

Turn off the radio (using the [POWER] button).

Press, **at the same time** the [N.R.] and the [LSB/USB] buttons.

While pressing [N.R.] and [LSB/USB] turn on your rig by pressing the [POWER] button.

The "Hello" message will appear on the display.

You can release the [N.R.] and the [LSB/USB] button when you see the "Hello" message.

You should enter the service menu.

To leave the service menu and to return your rig to the "normal" operating condition, you can do this:

press the [CLR] button **or** turn off your rig by pressing the [POWER] button, and then turn it back on by pressing **only** the [POWER] button again.

If you are unable to enter the service menu of your rig read the instructions above again and do each step slowly.

VERY IMPORTANT

Before tweaking *any menu* make a clean register of *all* the values on each menu. This way, if you mess up something, you can always go back by using the original value.

To do this, grab a piece of paper and once inside the service menu use the [M.CH/VFO.CH] button to go through the menus one by one.

Do not touch any other button!

Start with A0 and make a note of what you see. Turn [M.CH/VFO.CH] clockwise and you will go to A1. Make a note of A1. Repeat this procedure for all the items until you reach item BA. Item BB is impossible to copy (you will see why when you are there).

WARNING: *Do not* skip this procedure.

Another thing: I have found that different radios use different values, and this makes sense since there are *always* slight differences in similar equipments.

Now, let's see what each item is for.

A0 - System

This menu will give you the EEPROM checksum. The TS-870S service manual says that it's the "Program Version Confirmation". On my TS-870S, it reads:

FccA CHECK S

This menu can not be changed using any key on the front panel of your TS-870S and it will not affect the performance of your equipment.

Older rigs may have different values for the EEPROM checksum. To my knowledge this is the latest firmware version available to the 870S.

Some hams have reported that major DSP upgrade was made to the 870S before the release of this EEPROM version. Any comments?

A1 - ALC

This is a sensitive item and it will adjust the reference voltage the microphone ALC.

If you take a look at the service manual, the correct procedure for adjusting this menu is to connect a well calibrated digital volt meter to test point 2 (TP2) on the RF board (X44-3210-00) (A/9).

When measuring TP2 on the RF board the correct value will be 2.70V.

To adjust this value use the [RIT/XIT] button.

In my case, measuring TP2 for 2.70V led me to a value of 89.

Your rig may lead you to other value. By the way, to measure TP2 you will have to remove the bottom cover of your rig. I advise you not to.

So the original reading on my 870S was:

A1 89 89 ALC REF

But, I am not using 89. After trying out different values for the ALC I felt comfortable with FF.

To change to FF do this: turn [RIT/XIT] clockwise until you get this:

A1 FF 89 ALC REF

A1 is the menu number; FF is what you want; 89 is the original value;

ALC REF is the description of the A1 menu.

Now, we want to keep the FF value. By pressing the [UP] key you will get this:

A1 FF FF ALC REF

So you transferred the value you want (FF) and placed it over (89).

89 is no longer valid but it's not saved yet.

If you want to save this value for good, you will have to go into menu BA (use the [M.CH/VFO.CH] key) and press the [UP] key to save *all* the new information into the EEPROM.

After saving the info on the EEPROM turn your rig off using the [POWER] button. Turn it on again (use the [POWER] button) so the new settings can be read from the EEPROM.

When I said "*all* the new information" I mean that each and every menu that you have changed will be saved.

My advice is: change one item at a time and try out that item in particular. If not happy, go back to the original value.

In my case FF led me to a louder audio and to less shack noise into the microphone. Something that might be to worry is that fact that for the FF value, the reference voltage will be higher than 2.70V. I don't know how much higher because I haven't measured it but I have been working with this value for quite some time and *my* rig works fine.

Away, let's suppose that you are unhappy with FF and you want to go back to the original 89 value.

Just do this: go into menu A1 and turn [RIT/XIT] counterclockwise until you get this:

A1 89 FF ALC REF

Press the [UP] key and you will get:

A1 89 89 ALC REF

Now go to menu BA and press the [UP] key to record changes into the EEPROM. Now turn off the rig and turn it on again and you're back to the original setup. Easy, right?

A2, A3 and A4 - S-meter (SSB)

The S-meter was the reason that made me tweak the service menus in the first place.

On it's factory configuration my rig's s-meter was (most of the time) way bellow signal 9. Even with AM broadcast stations running several kilowatts I was unhappy with it because it was very difficult to go over 9, into the red area where 9+20, 9+40 and 9+60 dBs signals are located.

To adjust *properly* the s-meter you will need to generate some voltages. They are: -107dBm (yes, this is a voltage! It's just expressed in different units) for signal strenght 1. Then you'll need -81dBm for a 9 signal. Finally -23dBm for a full scale signal. This voltages are in the range of a few microvolts. After all that is what we get from our HF antennas. This voltages will have to enter the rig trough the antenna connector.

Keep in mind that if you try higher voltages in this input you will damage your rig.

Some hams out there have bench equipment capable of generating this voltages. Most of us can't do this, so here is what I did to adjust my s-meter:

The original values on my 870S were:

```
A2 xx 05 S.SSB.S1
A3 xx 60 S.SSB.S9
A4 xx 80 S.SSB.FUL
```

You can take a look at this values by going into menu number A2, A3 and A4. If you leave the antenna on and you have your rig on a SSB signal (any band is ok) you will see that the left numbers (above marked xx) will allways vary. This is normal and it's just your s-meter varying.

Since we want to get stable numbers on the left xx so we can copy this numbers into the right side (on top off 05, 60 and 80) we would need to disconnect the antenna and inject the user controled microvolt voltages until we have what we want.

The problem is the lacking voltage generator.

Here is a work around: connect a 50 ohm dummy load into the antenna connector. Turn the [RF] button fully clockwise.

If you are away from strong RF fields, now your readings must be:

```
A2 00 05 S.SSB.S1
A3 00 60 S.SSB.S9
A4 00 80 S.SSB.FUL
```

In my rig weak signals were fine, so I left A2 alone and I changed only A3 and A4.

I placed 30 in A3. You can do this by going into menu A3 and turning the [RF] button *slowly* conterclockwise until you have this:

```
A3 30 60 S.SSB.S9
```

Now, just press [UP] and you will get this:

```
A3 30 30 S.SSB.S9
```

For A4 I used a value of 60. So, using the same procedure, just get this:

```
A4 60 80 S.SSB.FUL
```

then press up and you have

```
A4 60 60 S.SSB.FUL
```

To save your changes go into menu BA and press [UP].

Now your s-meter will be much more sensitive and you will give better signal reports. :-)

Please notice what I said before. This is not a scientific way of calibrating the s-meter. The right way to do it is to generate the right voltages and place them into the antenna connector on the radio.

This is just a rough aproach that worked well in *my* case.

A5 and A6 - Filter

I haven't messed up with this so I can't help you here.

Anyway if you want to change this on your own (and tell me about it latter on) here are the original values on *my* rig and the keys for changing this values:

```
A5 00 00 8.83 FIL
A6 00 00 455 FIL
```

The [RIT/XIT] button will change the 00 left values between -99 and 99.

The [UP] key will place the left number into the right number.

Pressing [UP] on the BA menu will save your changes.

I have spoke to a great deal of TS-870S owners and just a few had made changes into the filters on this rig by placing in good quality filters (INRAD filters for example) instead of the stock filters. While the reports on the increase selectivity of rig seem to be true, I have been advised that the transmisson audio will loose quality because the TX bandwidth will decrease. Any info or comment on this subject is welcome.

A7 to AA - Power adjustment

Rumours say that this rig can go up to 150W.

My first comment on this: *if* it is capable of that and if you care about you radio *do not* increase the power to 150W. I think that you can damage the finals.

In it's factory configuration my TS-870S maximum SSB power was 95W.

I pushed the power a little higher into 110W (for driving my 2x3-500Z HF amp).

You will need a *calibrated* HF watt meter to do this. A Bird 43 will do just fine. Other calibrated HF meters will do.

Connect the power meter to the antenna connection of your rig. Then connect a 50 ohm dummy load *capable of handling more than 150W* to the power meter.

Go into A7. Press [SEND] and using [RIT/XIT] calibrate for 100W or your meter. When you're done press [SEND] again to stop transmitting.

The usual [UP] key will upgrade your value into the left number.

Going into BA and pressing [UP] will save your settings.

Before saving A7 I would advise you to ajust A8, A9 and AA. The procedure is identical. Make sure that you adjust A8 for 50W; A9 for 25W and AA for 11W (no, it's not a bug. I read "11W" on the service menu. If it's 10W and not 11W then the service manual has a bug!).

Then go to BA and save your changes.

AB to B3 - TX gain

If you adjusted the power off your rig you should also adjust this menus.

AB to B3 will adjust the TX gain on each band:

AB - 1.9MHz band
AC - 3.5MHz band
AD - 7MHz band
AE - 10MHz band
AF - 14MHz band
B0 - 18MHz band
B1 - 21MHz band
B2 - 24.5MHz band
B3 - 29MHz band

WARNING : I haven't found a way to return the settings on this menus to their original factory values. Actually I don't think there is a procedure for that. If you know how to this please contact me.

So, be carefull tweaking this menus. Once they are changed, *there is no turning back*.

Here's how to adjust the TX gain for menu AB. The procedure is the same for all the other menus (AB to B3).

Go into menu AB. You should see something like this:

AB 61 61 TxG 1.9M

Make sure you have a 50 ohm dummy load connected to your rig's antenna input.

Now, press [SEND]. You will see the left number changing. When the adjustment is complete you will ear a beep. Press the [SEND] key to stop transmitting into the dummy load. The left number must have changed. Suppose that now you have:

AB 72 61 TxG 1.9M

Now press the [UP] key to get the number into the right side. This is what you get:

AB 72 72 TxG 1.9M

Go to BA and save the data by pressing the [UP] key, but do this after ou have adjusted the TX gain for all the bands.

If you try this I would like to know about your results. I tried it on mine and it's working fine on all bands.

B4 to B6 - ALC meter

The ALC meter seems to be very sensitive and with my MC-60A microphone, in SSB, with volume at number 6 it saturates very easily. But, I have found the factory values to work well. In my case, the values are:

B4 10 10 ALC MIN
B5 20 20 ALC MAX
B6 30 30 ALC.FULL

I have changed this, but I ended up by returning to the same values.

I haven't spent much time tweaking this and I will try it again in the near future because I am not happy yet with the ALC bar graph behaviour.

The service manual says that to adjust these values you do this (suppose that we are adjusting B4): connect a 50 ohm dummy load into your antenna connection. Press [SEND] and the left number will vary and adjust itself until it stops varying. Then you can press [UP] and move the result into the right side. Menu BA will save things.

Now, please notice the following. These 3 menus are hard to tweak and if you remove the microphone you will get different values. When, at first, I changed this I thought that this was a "no way back" setup. After disliking my changes I wanted to go back to the original values and I struggled to find a way. Here it is: leave the 50 ohm dummy load on the antenna connection. Remove your microphone. Go to B4. For this one you want:

B4 10 10 ALC MIN.

Press [SEND] and slowly turn [MIC] until you have 10 on the left side.

This is a tricky adjustment because the number will keep on changing very quickly. When close to 10 try pressing [SEND] to stop TX and also to stop the number from changing. You may get a 10 on the left side.

If you went close to 10, try again.

After having 10, just press [UP] and it will go into the right side.

Now, you need 20 for B5:

B5 20 20 ALC MAX

I tried to get 20 on B5 and I *always* failed. So I went into B4 and I got 20 on the left side (same procedure as above). I *did not* press [UP] because I didn't want to mess up the B4 value.

I used [M.CH/VFO.CH] to change from B4 into B5. Guess what? The 20 value I had on B4 stayed there (on the left side) and went into B5. By pressing [UP] I updated [B5].

Now, try the same for [B6].

Also, on this menu, I am interested in your results.

B7 - SWR Protection

This item is very important because the value you choose here will trigger the SWR protection of the rig.

Changing this to a wrong value may cause the SWR protection to work too late (or not to work at all) and your rig will be transmitting into a high SWR. The consequences will be serious and you will ruin your finals (and who knows what else).

So *please* be careful playing around with this.

Anyway, for the brave of heart, here is the info on how to change this.

From the factory, mine had this:

B7 1E 1E SWR PROT

Go into B7 and by using [RIT/XIT] you can vary the left number from 00 to FF (256 different levels).

Pressing [UP] will update the right number.

BA menu saves your changes.

B8 - SWR meter

This will adjust your SWR meter. All 870s that I saw had SWR meters that worked really well, so if yours is working fine leave this menu alone.

If not, try this: you will need a 150 ohm dummy load (yes, not 50 ohm, but 150 ohm). Hook up the dummy load to the rig. Go to B8 and press [SEND]. The left number will change. Pressing [UP] updates the right number and menu BA will save your changes.

WARNING: doing this with a 50 ohm dummy load will ruin your SWR meter and will lead you to wrong SWR readings (if you use this meter).

B9 - FM Deviation

Factory settings on several 870s seem to be:

B9 80 80 Fm DEV

Going into menu B9 and using the usual [RIT/XIT] button will change the left number. [UP] will update the right number. BA menu will save your changes.

To adjust this menu properly you need special test equipment, so I would advise you to stay away from this one.

BA - System

Referred many times before.

Usually:

BA Ready EEPROM

"Ready" means that you can record on the EEPROM.
Pressing [UP] will record *any* and *all* changed menus.
Reply after recording must be:

BA Good EEPROM

BB - Display

This will light up all the LCDs and all the leds on the rig.
You can check for a bad LCD or for not working leds.

So, this is it.

You can find more information on this menus on the TS-870S service manual. Look on page 92 and the following pages.

I am always interested in learning more about this menus (and also other menus) on the 870.

If you are an Kenwood TS-870S owner and want to change thoughts about your rig fell free to e-mail me at:

joalopes@mail.telepac.pt.MODIFICATION.NET

I am interested in getting the factory settings of these menus for different Kenwood TS-870S. If you send your data in, please send also the serial number of your rig.

Remember that this article may contain incorrect informations (I've done my best to avoid that from happening). Also the info contained here can easily get you in trouble.

So remember the golden rule: "if my new setup is wrong I must be able to go back to the original factory value".

Keeping that in mind myself, I wish you
73s.

John, CT2HME

PS: Pardon my English. It's not my native language.

This modification is read 1947 times.

[top of page](#)

19-07-1998

(TS-930) TS-930S PLL Unlock

Author: Trio-Kenwood Communication, inc.

Service Bulletin no. 869 (29-3-1983)

Some users of the TS-930S have reported a problem where the PLL will sometimes not lock (digital display does not come on) if the power switch is turned off and on while xx.499.9 MHz is displayed, after the unit has warmed up. This may occur also in the FSK mode.

This may be caused by detuning of VCO-2 and VCO3 in the PLL unit (X50-1880-00). This may be cured by a simple increase in the voltage obtained in the PLL alignment procedure. Make the following change in your service manual.

Service Manual page 58.

3. VCO-3 T14 change 3.7v to read 4.2 vdc
4. VCO-2 T15 change 3.0v to read 3.5 vdc

Notes:

Be sure to adjust T14 and T15 of VCO-2 and VCO3 whenever a PLL related circuit is serviced.

This change applies to units before S/N 306XXXX.

Installation time for this change is 1/2 hour or less.

This modification is read 1189 times.

[top of page](#)

Author: Trio-Kenwood Communication, inc.

Service Bulletin no. 877 (23-8-1983)

Some of the symptoms and cures for troubles that have been encountered with the AT-930 are listed below.

1. The motors do not stop on all bands.

Possible causes:

- a. Cold solder joint of platee VCJ wire.
- b. Cold solder joint of L18 lead.
- c. Cold solder joint of the wire between pin 13 of Q39 and R139, D33 and R138.

2. The motors do not stop on the 7 MHz band.

Possible Cause:

The rotor of VC2 contacts (shorts against) the stator.

3. The motors do not stop on the 28 MHz band.

Possible Cause:

Cold solder joint between D33 and R84

4. The AUTO mode does not reset.

Possible Cause:

The wire from R138, R139 and D33 may touch Q39 pin 14.

5. The motor stop when SWR is at Maximum.

Possible Cause:

The wire from R138, R139 and D33 touches Q39 pin 14 and the foil is broken around VC1.

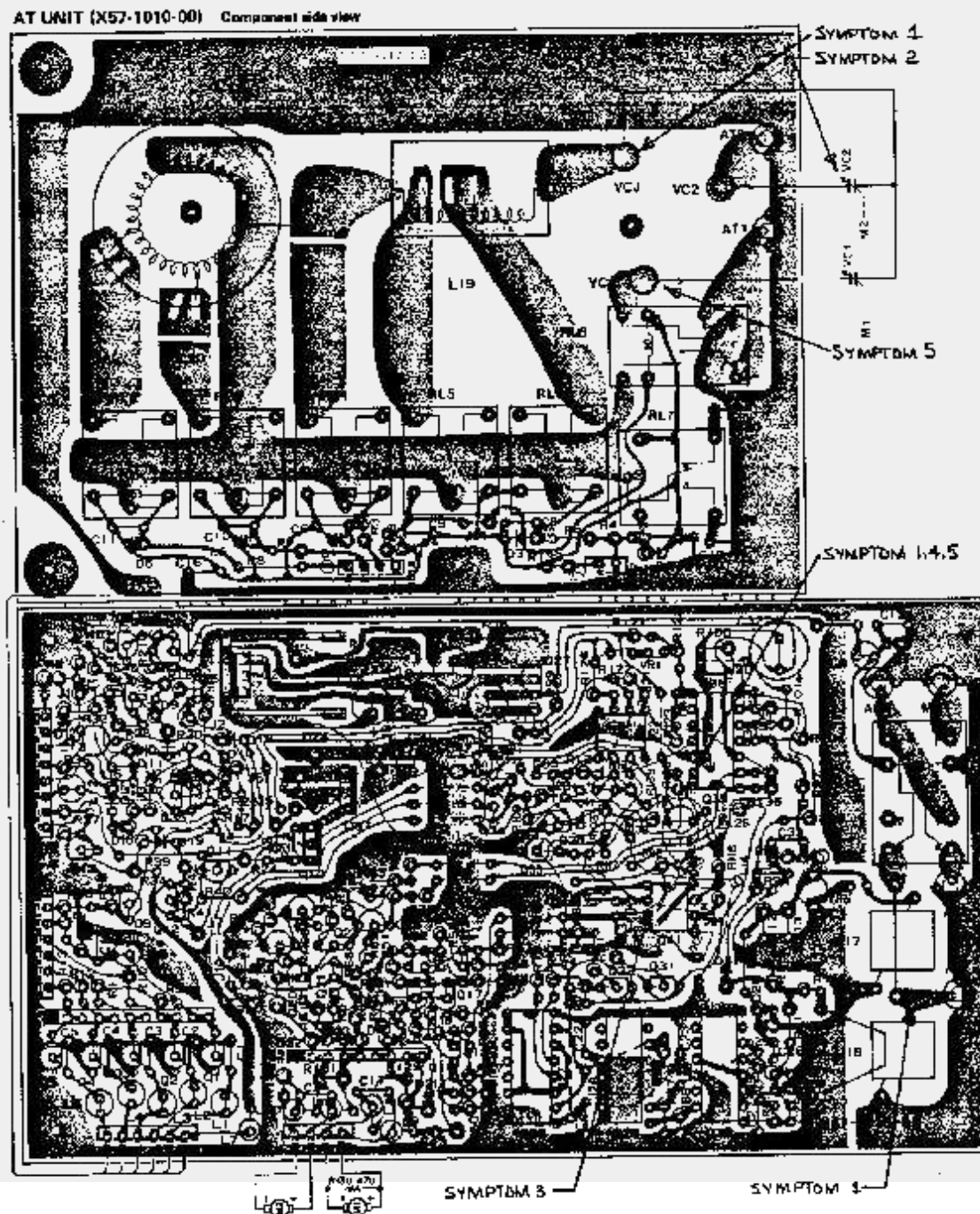

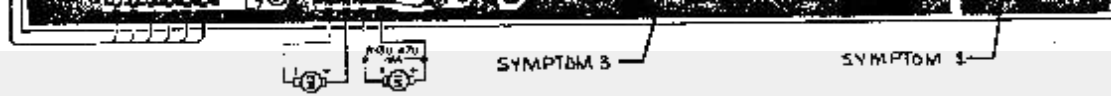

This modification is read 1057 times.

[top of page](#)

19-07-1998

(TS-930) TS-930S Intermittent TX Power Output

Service Bulletin no. 886 (11-5-1984)

The following procedure should correct any tendency of the TS-930S to exhibit intermittent TX power output. Most of the reported cases of this nature have been traced to poor contact of one or more plated thru holes mentioned below. Careful adherence to this procedure should prevent reoccurrence of this symptom.

Procdeure:

1. Remove the top and bottom covers.
2. Remove the 10 screws securing the final unit to the chassis.
3. Disconnect all cable assemblies from the final assembly, and remove it from the radio. The fan motor cable may have to be removed for easy access.
4. Remove all Final Unit PC board screws and turn the circuit board foil side up.
5. Desolder Q6, D2, and the plated-thru hole connecting the foils from R20 and Q8 base together (between T2 and VR1). Do not remove the components!
6. Carefully remove the green solder resistant coating from the immediate areas of these six points, so that there is bare copper foill up to and surrounding the eyelets.
7. Carefully resolder these six points, and those listed below:
 - Q1 Emitter and base
 - D4 anode and cathode
 - Q2 Emitter and base
 - Q3 Emitter and Base
 - Q7 Emitter and Base
 - Q4 and Q5 Base and collectors
 - Plated-thru hole between C36 and C15
 - (2) Plated-thru hole sby the molex connector.Check and resolder the input and output coax connectors.
8. Double check your work to ensure that there are no solder bridges or splashes.
9. Check the value of R19. If it is not 6.8 K ohms, change it so it is.
10. Reinstall the final assembly, and readjust the idle bias currents of the driver and final transistors in accordance with Service Bulletin 867.

CAUTION:

Ensure that no cables are pinched between the final assembly and chassis when reinstalling the final unit. The fan cable is especially vulnerable, so pay close attention!

This modification is read 1070 times.

[top of page](#)

19-07-1998

(TS-930) Tuning Mods TM-930

1. The resolution of the main tuning digital readout can be increased from 100Hz to 10Hz. No digits are lost since the readout has the extra digit for this purpose. This change can be accomplished by grounding pin 1 of connector 8 on the digital unit PCB.
2. The tuning rate is 10KHz per revolution of the main tuning knob.
The tuning rate can be changed to 5KHz per revolution by removing or lifting one end of diode D-13 on the digital unit PCB.
3. Note that the black marks on the tuning knob itself are exactly 500Hz apart. The knob can be "corrected" by tuning in an exact frequency, such as 10,000.00KHz, pressing the DIAL LOCK switch, then turning the knob to line up a black line. As long as you don't spin the dial too fast, it will track nicely from one end to the other. With the slow rate tuning modification above, the dial increments become 250Hz per division.
4. You may desire to switch the new reduced tuning rate on and off. For example, you can select the new rate on just VFO B by using an unused section of the FUNCTION switch to make or break the circuit on diode D-13. Another pssibility is to use the display DIM switch.
5. There are an additional 8 memories available. These can be util- ized by grounding pin 5 of connector 7 on the digital unit PCB. This lead is designated as "M3". The additional memories can be selected by using the unused contac on the FUNCTION switch or by adding a new switch.

19-07-1998**(TS-930) Amtor keying mod**

1. Look at the signal board and locate C500. C500 is an electrolytic 4.7uF located near the center of the board (if viewed with the radio upside down with the front facing you) near connector 30.
2. Remove this capacitor by carefully twisting it with a pair of needle nosed pliers. This capacitor cannot be easily removed any other way without completely disassembling the radio. The function of this capacitor was to de-bounce the PTT switch and is a big reason why the TS-930 will not work satisfactorily in AMTOR mode.
3. Next, locate R476 which is on the same board as above and is positioned just above the large CW filter. The lead that is exposed needs to be grounded. An easy way to do this is to locate R474 which is right next to R476 and scrape away some of the insulation from both of the exposed leads, then solder a bridge between them.

19-07-1998**(TS-930S) TS-930S CW Pitch Tone Shift****Author:** Trio-Kenwood Communication, inc.

Service Bulletin no. 872 (6-7-1983)

Some users of the TS-930S have reported a slight change in the CW pitch tone when the MONI switch is turned ON and OFF.

This may be corrected by changing the following components:

On the Signal unit (X57-1000-XX) change R826 from a 1 K ohm resistor to a 10 K ohm resistor and remove C601, a .022uF capacitor from the foil side of the circuit board.

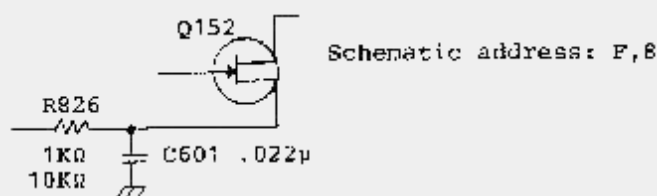

SIDETONE MIXER

Component side view

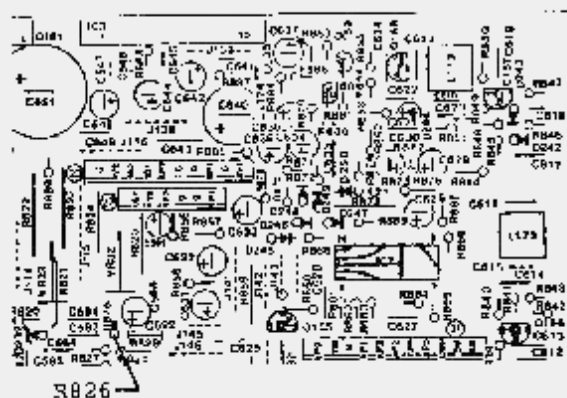

Foil side view

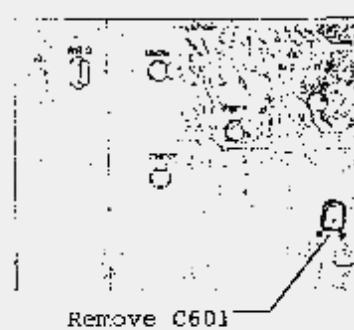

Notes: This change is applicable to units before serial number 3070221 only.

19-07-1998

(TS-930) TS-930S 15 Meter Internal Beat Tone

Author: Trio-Kenwood Communication, inc.

Service Bulletin no. 884 (27-1-1984)

Some users have reported an internal beat tone that appears every 10 KHz, when operating in the range of 20-21.5 MHz. Apparently the RV terminal switch unit H is being affected by the 1st loop of the PLL unit. The cure is relatively simple. Add a .01 μ F 50V disc ceramic capacitor on the RV line of switch unit H as shown below.

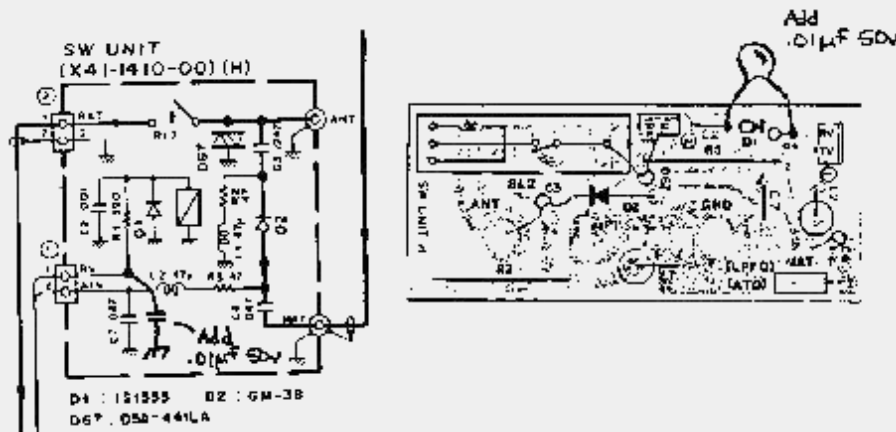

Time required for this modification is 1/2 hour or less.

Date: 24-01-2002	User comment	From: george crenshaw, W6ixv
Subject: 15 meters internal beat tone		

I have two kenwoods 930s and tried your modification. That described did not work at all. still have beats every 10 kilocycles, strong as ever.

This modification is read 885 times.

[top of page](#)

19-07-1998

(TS-930) TS-930S RF Feedback

Author: Trio-Kenwood Communication, inc.

Service Bulletin no. 874 (15-7-1983)

For reports of RF feedback from the external speaker, especially when using a vertical antenna, or a linear amplifier, check for correct installation of capacitor C16 on the EXT SPKR jack.

C16 should go from ground to the white wire on the opposite side of the jack. Some units have the capacitor soldered to the middle terminal in error!

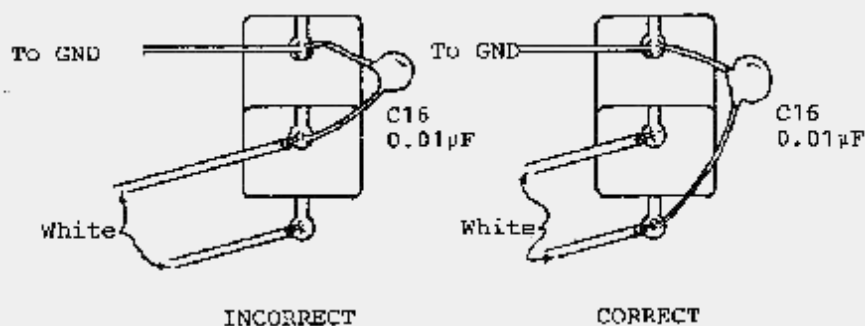

Note: This bulletin is applicable to radios with serial numbers prior to 3070420. Time required for this procedure is 1/2 hour or less.

This modification is read 927 times.

[top of page](#)

19-07-1998

(TS-930) TS-930S SSB TX Tone Quality

Author: Trio-Kenwood Communication, inc.

Service Bulletin no. 867 (29-3-1983)

The transmitted audio tonal quality of the TS-930S may be improved by the following procedure:

In the TS-930S Service Manual page 64, make the following change:

5. 100 W Final Bias VR2 adjust for 70 ma
VR1 adjust for 1.3A

Note:
This change is applicable to units with serial numbers prior to S/N 3080001.

This modification is read 973 times.

[top of page](#)

24-01-1999

(TS-930) Error in the operator's manual of the DIGITAL UNIT pin

Note: In the operator's manual supplied with the 930, there is an error on one of the drawings. On the upper left corner of the DIGITAL UNIT schematic locate connector 8. The lead designations are as follows (note that some of the designations do not appear on this sheet so you can add them to the drawing):

Pin	Desig.
1	100
2	MU
3	SCN
4	M2
5	MIN
6	FSK
7	B2
8	FT

On the main drawing, called SCHEMATIC DIAGRAM, the pin numbers shown on connector 8 are reversed from the way they are numbered on the DIGITAL UNIT schematic. In the following changes, I am assuming that the numbering on the DIGITAL UNIT sheet is correct. In any event, it will be obvious which end is which since the end pin is vacant.

This modification is read 918 times.

[top of page](#)

09-04-2000

(TS-930) Incorrect AC line voltage setting

Author: Trio-Kenwood Communication, inc.

Service Bulletin no. 863 (22-10-1982)

It has been found that a few TS-930S (and other) transceivers have been shipped in the 220V or 240V line position. If you should encounter an initial transceiver failure, please check for correct line voltage selector setting. The voltage selector is located on the bottom case at the rear of the unit.

This modification is read 929 times.

[top of page](#)

09-04-2000

(TS-930) TS-930S CW Hetrodyne Tone

Some users of the TS-930S have reported that a heterodyne is heard when the VFO control is turned in the CW mode. The tone may be more noticeable with no signal present, (e.g. no antenna connected.), or when the AF tune or CW PITCH controls are tuned. This may be reduced or eliminated by the following procedures.

Parts required

Qty	Description	Kenwood part number
1	Shield Kit	Z930CARSHIELD
	Cover CAR 1	F11-0813-04
	Shield CAR 1	F10-1308-04
	8.2 Kohm $\frac{1}{4}$ Watt Resistor	
	22 Kohm $\frac{1}{4}$ Watt Resistor	
	3 pF disc capacitor	
	.5 pF disc capacitor	
	1 pF disc capacitor	

Procedure

1. Remove the top and bottom covers from the TS-930S.
2. Turn the radio bottom up to allow access to the Signal unit (X57-1000-11).
3. Remove the twenty-two (22) screws that secure the Signal Unit/Heat sink to the chassis. Unplug the RAT, DRV, XVT, FRQ and the VCOF coaxial cables from the Signal unit. These are located along the rear and the left side of the Signal unit. Unplug connectors number (16) and (20) located along the right of the Signal unit.
4. Gently lift up on the rear of the Signal unit and fold the board over towards the front panel to allow access to the bottom of the board.
5. Install the shield plate as shown in figure 1. Cut the circuit foil and add the jumper wire as shown.
6. Change the following components:

Change R635 to 8.2 Kohm
Change R501 to 22 Kohm
Change C469 to 3 pF
Change C473 to .5 pF
Change C476 to 1 pF
7. Reinstall the Signal unit. Pay careful attention to the coaxial connectors when reinstalling to ensure they are in the correct locations.
8. Install the top cover to CAR 1 enclosure to complete the Signal Unit modification.
9. Turn the set over so top is up. Remove the four (4) screws that secure the speaker assembly to the chassis and lift up gently (unplug the battery backup connector). The assembly may then be folded over to the right with cables attached. Remove the four (4) screws that secure the Digital assembly to the chassis and fold the assembly up and towards the front panel, to allow access to the PLL unit.
10. Remove resistor R73 and capacitor C99 from the PLL unit.
11. Reverse the procedure in step 9 to reinstall the Digital and Speaker units.

Adjustments.

1. Connect an oscilloscope probe to the CAR 1 terminal (24) of the Signal unit. Adjust L161 for 300 mV p-p signal amplitude.
2. Connect the oscilloscope probe to the emitter of Q79.
Adjust L142, L144, and L145 for maximum signal amplitude, then adjust L139 for 1 V p-p amplitude.
Note: Note the USB frequency before adjusting L139
3. Adjust TC4, TC5, and TC6. (Refer to Service Manual)
4. Adjust TC3 so the frequency is again the same as measured in step 2.
5. Replace top and bottom covers to complete the modification.

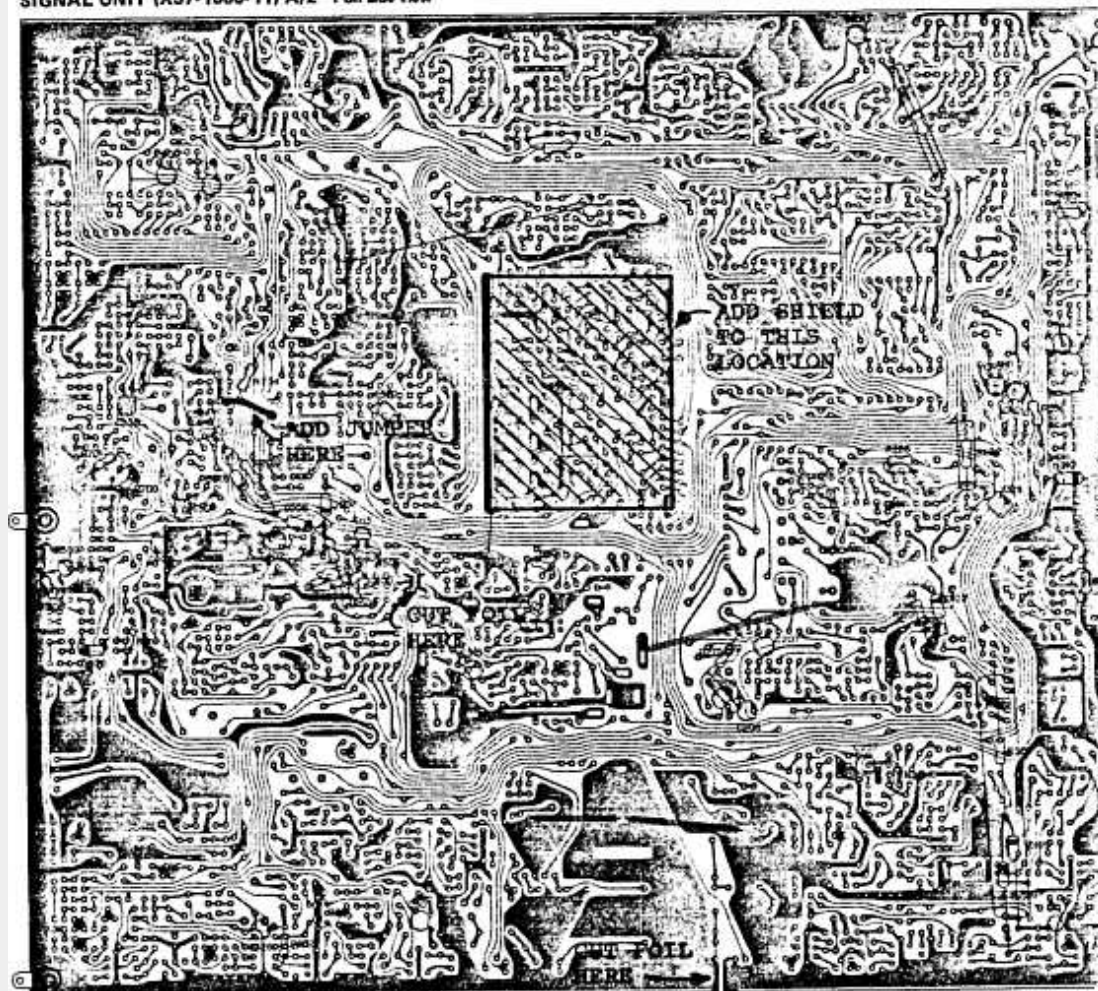

Figure 1

This modification is read 885 times.

[top of page](#)

09-04-2000

(TS-930) TS-930S Low RX sensitivity

Author: Trio-Kenwood Communication, inc.

Service Bulletin no. 868 (29-3-1983)

A loss of receiver sensitivity (6-30dB) may be caused by shorted switching diodes in the Signal unit (X57-1000-xx). The following procedure will increase the capability of the unit to withstand high RF voltage levels.

Procedure

Signal unit (X57-1000-xx)

1. Replace Signal unit jumper J27 with an XZ-070 Zener diode.
(PCB coordinate C-1, see figure 2.)

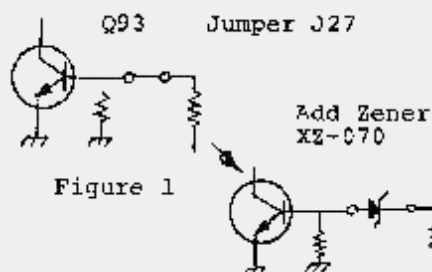

Figure 1

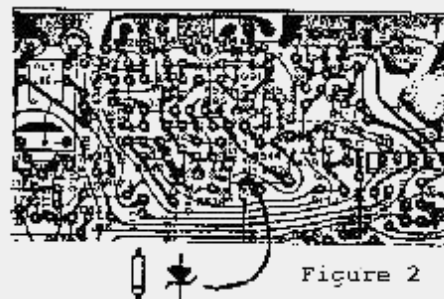

Figure 2

2. Change diodes D15 through D33 from BA2B2's to 1S2588's. Change only the defective diodes when making the repair.
3. Figure 3 show a circuit that is capable of withstanding antenna input levels of up to 50 Watts. Use this on units that may be subject to high levels of RF. (This is an optional change that may not be done in-warranty.)

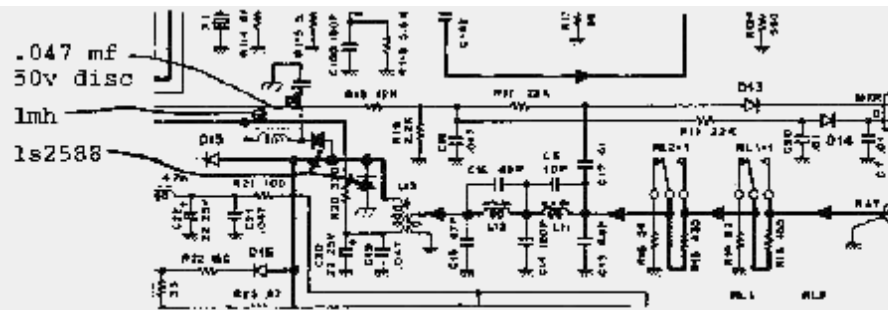

Figure 3

Installation time for this procedure is ½ hour or less.

This modification is read 1042 times.

[top of page](#)

09-04-2000

(TS-930) TS-930S CW VBT

Author: Trio-Kenwood Communication, inc.

Service Bulletin no. 873 (15-7-1983)

This procedure will allow a simplified alignment method for the TS-930S CW VRT section, when a VBT-1 jig is not available.

Test Equipment required

- o Oscilloscope
- o Audio signal generator (2)
- o AF VTVM

Procedure

1. Preset the TS-930S controls as follows:
 1. MODE: LSB
 2. Disconnect the DRV connector from the Signal unit.
 3. Confirm that CAR2 frequency is the same when switched from transmit to receive. If it does not stay constant adjust VR23.
2. Connect the oscilloscope probe to R176 in the Signal unit.
3. Connect the two Audio Generators as shown in the figure below. Set AG1 to 300 Hz and AG2 to 2.9 KHz.

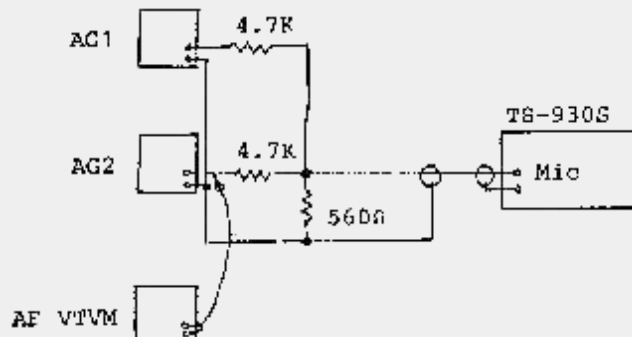

4. Ensure that the output level of AG1 and AG2 are equal by using the AT VTVM.
5. Connect the cathode of D133 to that of D132 in the Signal unit using a 0.01 μF capacitor.
6. Clip the lead of D124 and place the STBY switch to SEND.
7. Adjust TC4 (CAR1 8.8315 KHz for USB) so that complete tone waveform is observed, as shown in figure 2. Return to REC, and resolder D124.

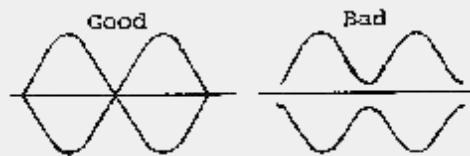

Figure 2

8. Remove the 0.01μF capacitor installed in step 5.
9. Set STBY to SEND and adjust TC3 (CAR2 8.375MHz) so that a complete two tone signal is displayed, as in Figure 2.
10. Return to REC, and reconnect the DRV connector. This completes the simplified alignment procedure.

This modification is read 901 times.

[top of page](#)

09-04-2000

(TS-930) TS-930S Audio oscillation

Author: Trio-Kenwood Communication, inc.

Service Bulletin no. 875 (16-8-1983)

Some users have reported an audio oscillation when the AF gain control is set between 10:00 and 12:00.

The cause may be that Signal unit (X57-1000-xx) capacitor C642 is installed backwards. See figures below. Please change your service manual schematic to reflect the correct positioning when you check the board.

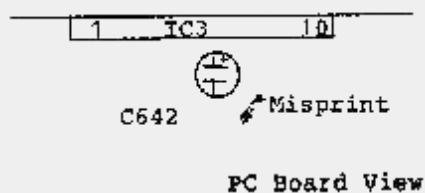
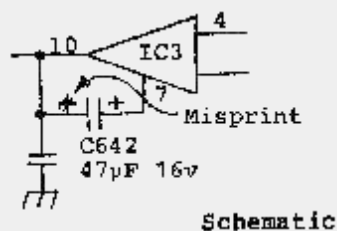

Note: This change is applicable to units before S/N 307xxxx.

This modification is read 892 times.

[top of page](#)

09-04-2000

(TS-930) TS-930S Feedback into MIC CRT

Author: Trio-Kenwood Communication, inc.

Service Bulletin no. 876 (16-8-1983)

Some users may report RF feedback to the MIC at low frequencies, for example: 3.5 MHz.

Make the following changes to SW unit (J) (X41-1410-00):

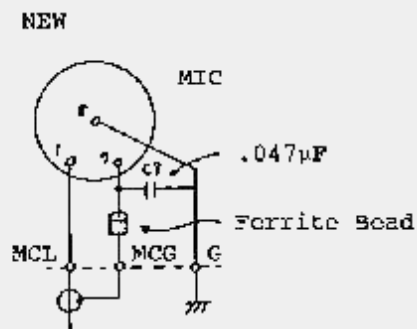
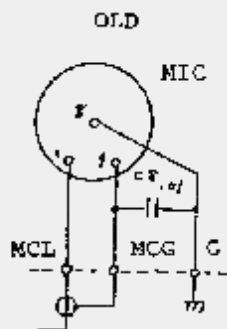

Foil side view

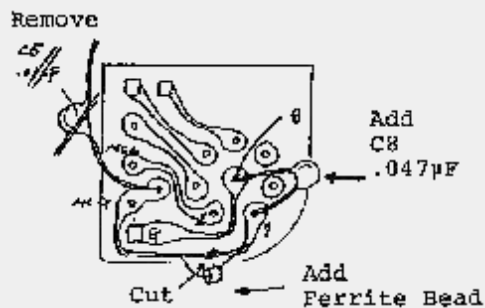

Note: This change is applicable to units before S/N 308xxxx.

This modification is read 897 times.

[top of page](#)

09-04-2000

(TS-930) TS-930S ALC level drift 28 MHz CW

Author: Trio-Kenwood Communication, inc.

Service Bulletin no. 879 (25-8-1983)

Some users have reported that the ALC meter indication occasionally jumps during long key down periods on the 28 MHz portion of the bands. The symptom may be caused by the ground foil of the Final unit (X56-1430-00) coming in contact with one or more of the projections on the final heat sink, due to expansion when the temperature rises.

Apply Mylar insulating tape to the projections on the heat sink, to prevent reoccurrence of this symptom. See figure below.

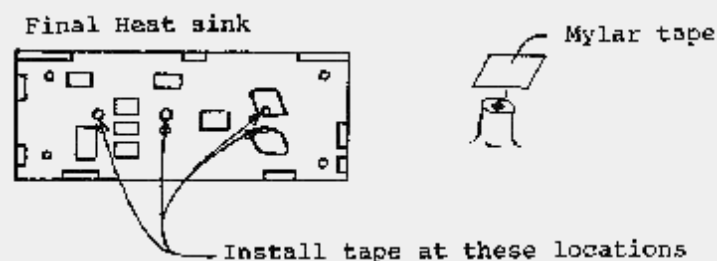

Notes: This bulletin is applicable to units prior to serial number 3080001.
Time required for this modification is ½ hour or less.

This modification is read 879 times.

[top of page](#)

09-04-2000

(TS-930) TS-930S Power Supply surge protection

Author: Trio-Kenwood Communication, inc.

Service Bulletin no. 881 (27-10-1983)

A line surge (exceeding approximately 4.5 kV) due to static electricity or nearby lighting discharge may short power relay diode, D2 (V06E), and cause electrolytic capacitor C14 (3.3 μ F to break down. This results in relay chatter and the relay contacts may finally weld.

Addition of the surge absorber to the primary power supply input circuit, as shown below, should help avoid this type of failure.

Note: This symptom has occasionally occurred in those limited areas subject to frequent and violent lighting discharges. A good earth ground and antenna system lightning protection is still strongly recommended.

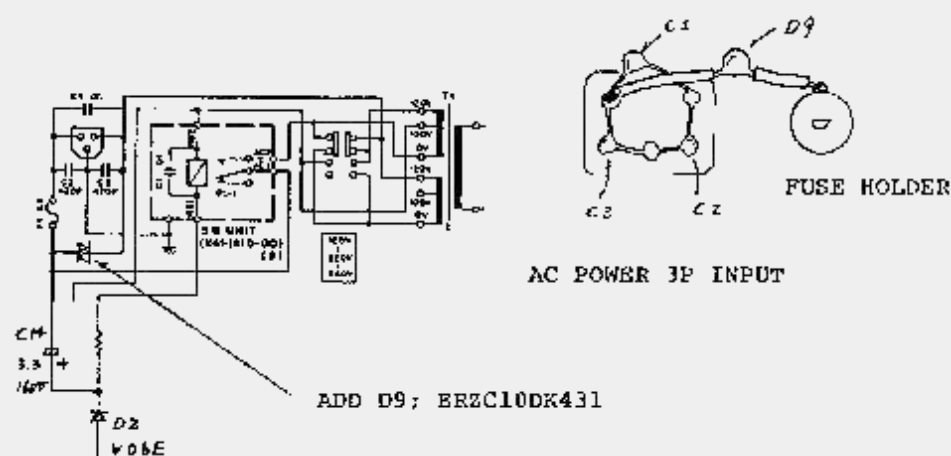

Note: This change applies to units before S/N 3080301.

This modification is read 983 times.

[top of page](#)

15-04-2000

(TS-930) TS-930S Noisy Power Supply Fan

Author: Trio-Kenwood Communication, inc.

Service Bulletin no. 893 (3-1-1985)

Some users of the TS-930S have reported that the Power Supply Fan motor makes excessive noise. This fan motor was originally designed to drive a pulley system. By adding a small amount of lateral tension to the motor shaft this noise is reduced or eliminated. The procedure listed below should correct any tendency of this motor to make noise.

Parts Required: Flat Spring Part Number: G02-0549-04

Add the Flat Spring as shown in the figures below.

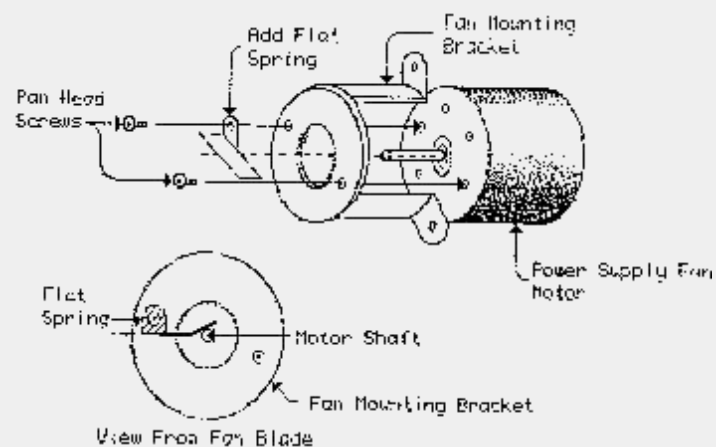

Time required for this modification is ½ hour or less.

This modification is read 979 times.

[top of page](#)

27-05-2001

(TS-930) Expanded R.F. on the Kenwood TS 930 S

Author: Bill Wallace KC4YRN

1. Disconnect the power and antenna.
2. Remove the top and bottom covers of the radio.
3. Remove the four screws from the speaker mounting and the top panel assembly.
4. Swing the assembly away and unplug the Red/Black battery leads from the digital unit X54-168-00.
5. Solder small ga. wires between the following locations.

IC21 pin 12 to IC11 pin 9
IC22 pin 12 to IC12 pin 9
IC23 pin 12 to IC24 pin 8

Tack soldering on the component side of the board is O.K.

6. Reassemble the radio

You should now be able to Transmit on the MARS/CAP frequencies.

Bill Wallace KC4YRN

This modification is read 1377 times.

[top of page](#)

Author: Trio-Kenwood Communication, inc.

Service Bulletin no. 0045 (29-10-1983)

SUBJECT:

Digital Unit through-plated hole defects and their symptoms

CONTENTS:

The unit shows symptoms as listed below, when any of the 56 Digital Unit through-plated holes are open. These examples were compiled by Mr. Negishi of the Kanto service center. Make full use of the Material as a technical reference for repair.

Through-hole No.	Symptom
1	(GND)
2	(GND)
3	Transmit mode not entered.
4	N/C
5	No display. However, pressing the BAND switch operates the BAND changeover relay.
6	Transmit mode not entered.
7	N/C
8	RIT operates in transmit mode.
9	Continuous tone and no display.
10	RIT operates in transmit mode.
11	(GND)
12	(GND)
13	Continuous sound. All indications are displayed.
14	(GND)
15	(GND)
16 & 17	No display, display disappears when main dial is turned, or display appears when main dial is turned (when nothing is displayed).
18	Turning the main dial generates an abnormal sound. The abnormal sound increases as the receive frequency is approached.
19	No display. However, 80.888.8 .88 is displayed when connector 9 is removed.
20	No display or 54.444.4 is displayed.
21	36.222.2 or 14.444.4 is displayed.
22	RIT-1.1 kHz is displayed when an odd numbered frequency is displayed.
23	Only the 'g' segment of the display lights; "-"
24	
25	
26	No display or only segments "egf" light. "1-"
27 & 28	The main dial and UP and DOWN switches do not operate.
29	
30	Only segments "g, DP" light.
31	Many analog pointers light. The brightness of the pointers varies widely.

32	All 'g' segments light. "----- "
33	The "DP" segment remains continuously it.
34	Analog values from 0 to 700 are displayed, but values from 700 to 1000 are not.
35	Segments "b,g" only are not displayed. Some of the analog pointers do not light.
36	
37	No display because UL.
38	No display, continuous tone.
39	Three digits of values are not displayed ex. 14.XXX.5
40	
41	
42	
43	
44	
45	
46	
47	
48	(The main dial does not operate.) 14.000.0 is displayed. Turning on the RIT switch displays 14.100.00.
49	Continuous tone. Display is locked, RIT is turned ON and 14.001.4 is continuously displayed. Transmission is no possible.
50	Frequency varies.
51	As if scanning were being performed. Transmission is possible.
52	
53	
54	
55	
56	

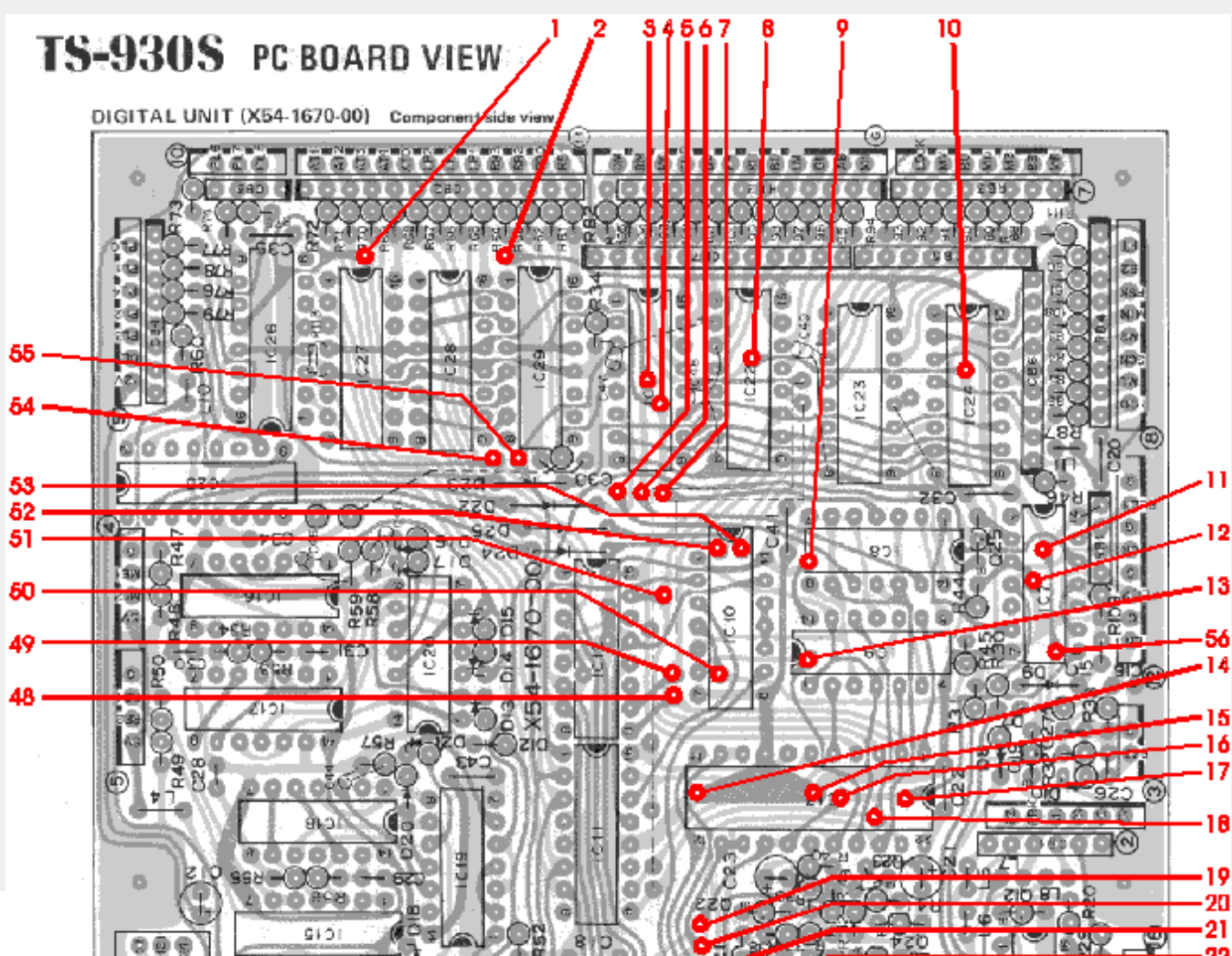

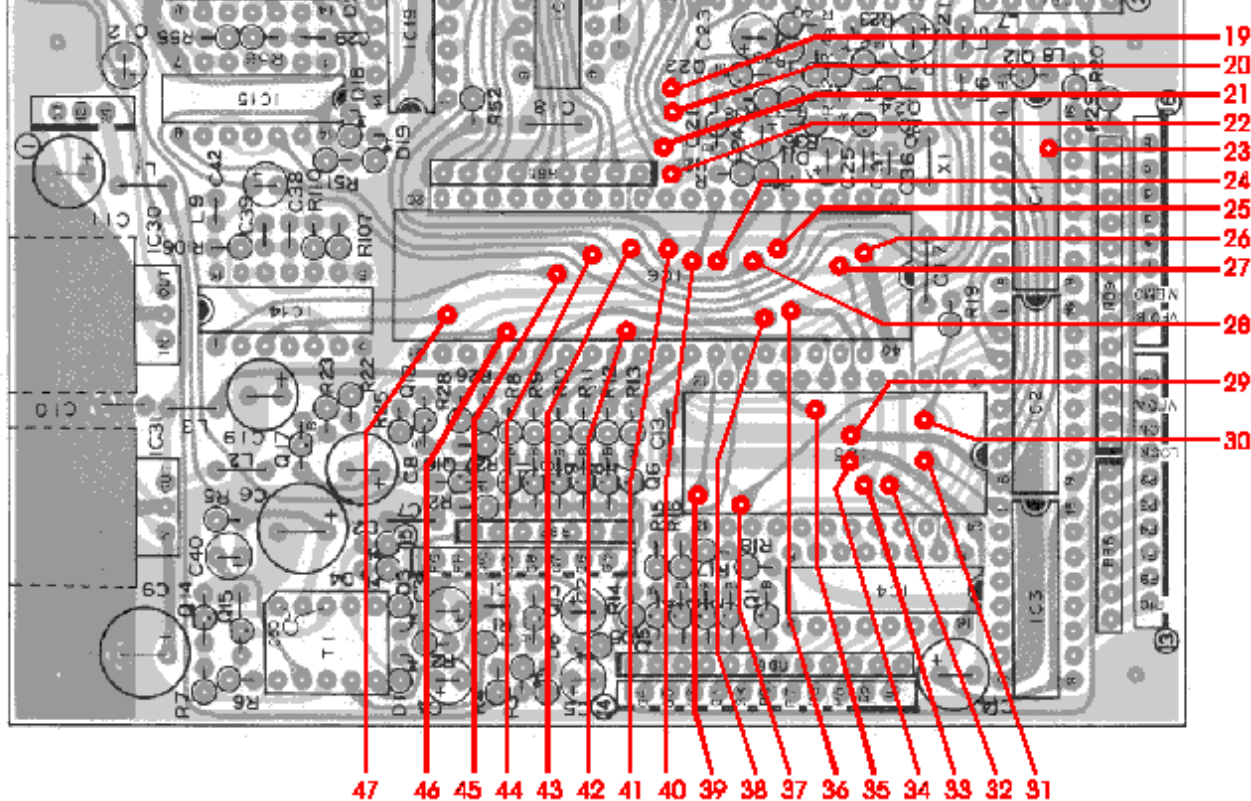

This modification is read 49 times.

[top of page](#)

24-03-2002

(TS-930) W6NL Mods for the TS-930 (Very long)

Author: Dave, W6NL - leeson@earthlink.net. MODIFICATION.NET

Introduction

The Kenwood TS-930, while many years out of production and lacking many of the technology developments of the past twenty years, continues to be an excellent HF radio with a unique ability to hear multiple signals in a pileup. This particular performance advantage has, for whatever reason, eluded the designers of more modern radios. As a partner in the new HC8 contest station on Isla San Cristobal, I undertook to obtain and refurbish a number of 930s, but we were disappointed by the lack of reliability we experienced.

The problems we observed included

1. Several radios experienced outright power supply failure, and one had a difficult-to-trace low frequency oscillation in the 28V circuit that involved the output amplifier, and destroyed amplifier driver bias transistors (this was cured by replacing the 2N5885 regulator transistors).
2. One radio experienced intermittent loss of receiver sensitivity, and another experienced loss of microphone input on SSB.
3. AGC overshoot made reception difficult of signals in the range of S9+ 20 dB.

I aligned each radio and ran it for a four-day period at high transmitting duty cycle on CW and SSB, using computer logging software to transmit into a dummy load (which itself required a cooling fan). At the end of the burn-in period I checked for unchanged sensitivity, power output and fan operation. Despite this we experienced failures in contests, with the requirement to return the radios to the US for repair.

I was aware of the change of TS-930 design at S/N 310XXXX that responded to the many early problems (digital board through holes, amplifier through holes, receiver muting, sidetone, etc.) that are well documented in listings of modifications, as well as in Kenwood's application notes. Our radios have serial numbers ranging from 4M to 8M. All have been standardized to the same configuration, so we would be able to separate the sources of any problems. All our radios have the stock CW and SSB IF filters (TS-930 SSB filters are wider than the pin-compatible ones for TS-940/850) and the PIEXX digital board, both for reliability, new functions such as main tuning knob control of RIT when dial is locked, and to be able to use computer logging and control.

It should be noted that the power situation at the end of a long rural line is not favorable, nor is the fact that our radios experience the rough handling as airline baggage (even in the excellent foam-lined Pelican cases) and then sit idle for extended periods in the foggy and humid equatorial mountain-top air. In order to minimize our exposure to line voltage variations and surges, we configured all the radios for 240V operation and used professional-grade surge protection. The short line cords are a unique color and are firmly attached to the radios so other equipment in the shack cannot inadvertently be connected to 240V through the standard EIA connector. We have the option to switch to 220V if the line voltage sags, although that has not been necessary.

With the modifications outlined in this note, our TS-930s now exhibit excellent reliability, and have worked well for the entire preparation and contest time in both modes of the recent CQWW contest. I thought there might be some interest in what I found was required to make them bulletproof.

Replacing TS-930 Resistors and Shunt Zeners with Series Regulators

The TS-930 power supply for serial numbers higher than 310xxxx generates two voltages, 28.5V for the power amplifier and antenna tuner, and 21.7V for the digital board and the signal board. The 28.5V is regulated by the two TO3 pass transistors on the heat sink, and the 21.7V is generated by separate transformer secondary taps and diodes that generate 31.9V which is reduced to 21.7V by the TO220 transistor on the power supply heat sink.

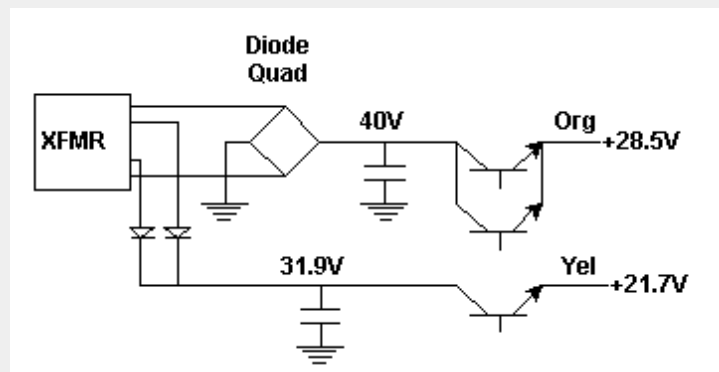

The power switch has a pole that opens the +28.5V to most of the radio, including the circuit that runs the 21.7V regulator. This is apparently so the radio will just turn off without the time delay and rude noises of the filter capacitors discharging.

The power supply uses high-wattage resistors and zener diodes in the power supply fan case to reduce the 21.7V secondary supply voltage 7.5V and 15V for the digital board (which has 5V and 12V regulators) and for the signal unit, which has an 18V regulator. The 21.7V is distributed by the yellow wires via a black terminal block between the antenna tuner and the filter unit; this block also has the switched +28.5V orange wires. The original circuit looks like this:

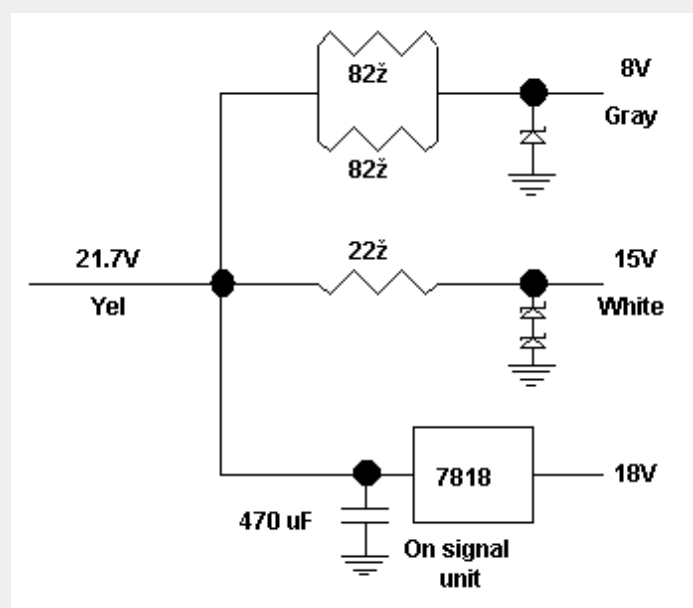

The main schematic diagram of the radio is wrong, it shows the 33Ω resistor that is the third supply voltage for the digital board connected to the 21.7V instead of the 28.5V line.

The dissipation in the resistors and diodes is above their ratings, and this could be a reliability problem. This new circuit replaces the resistors and diodes with 78xx 1 A. TO220 regulators mounted on the power supply heat sink. In addition to having less dissipation, the regulators are short-circuit proof. There are holes in the heat sink, and the TO220 tabs can be bolted with 4-40 small-pattern nuts and bolts. I use a locking compound on the bolts so they won't vibrate loose later.

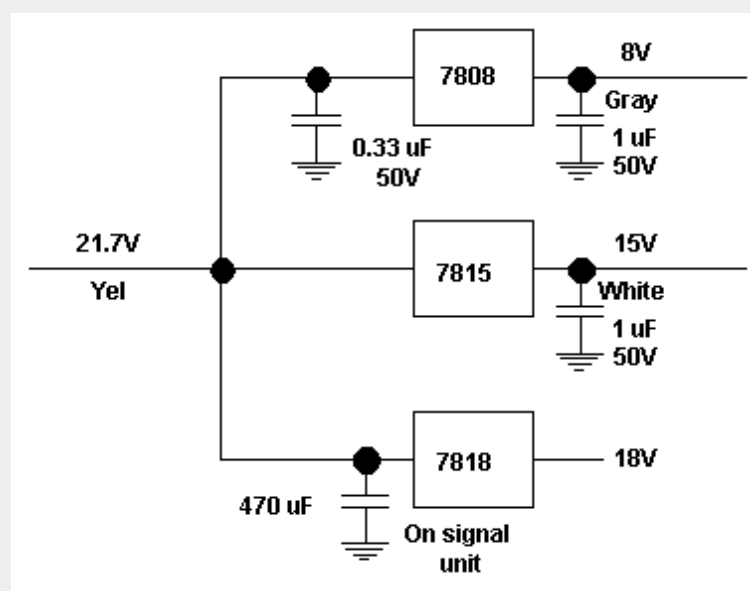

The regulators need capacitors near them, especially if they are driving the PIEXX board, which has switching regulators with inductors at the input. The regulators should be prewired, and the wires are connected to the voltage points inside the power supply fan case.

To make the change, proceed as follows (the same steps are necessary to replace the pass transistor with an NTE377, if the original is burned out).

1. Unplug the radio and remove the top cover.
2. Remove the four black screws holding the fan case onto the heat sink, and unplug the fan wire from the power supply board so it won't break at the fan connection. Free the tab from the case bottom, and tip the case down and put something under it to hold it horizontally to work on.
3. Remove the remaining two black screws holding the power supply heat sink to the radio. You will find the heat sink will not tip out without additional work.
4. Unscrew the screw holding the diode bridge to the heat sink. This screw will be retained by the heavy wires from the transformer, so you don't need to pry it out completely, just free the diode quad from the heat sink so the heat sink can move.
5. Remove the two lugs and heavy red wire from the TO3 pass transistors by unscrewing the two middle screws while holding the nuts with long-nose pliers on the inside. Leave the screws in place in the transistors to hold the insulating washers.
6. Now you can tip the heat sink forward far enough to be able to reach the screw that holds the pass transistor. This transistor has had loose screws in some radios, so tighten it up while you can. If you unplug the pass transistor, be sure to note which way the plug goes on (some have plugs, some have the blue, green and violet leads soldered on and covered with heat shrink tube).
7. Locate the field of small holes near the upper edge of the heat sink, near the outside edge of the radio. As viewed from inside the radio, the two regulators mount to the holes in the bottom row (the top row is also OK, and easier to reach if you are not removing the heat sink). Before you do anything else, route the wires from the regulators beneath the heat sink so they can be connected to the terminal strips in the fan case.

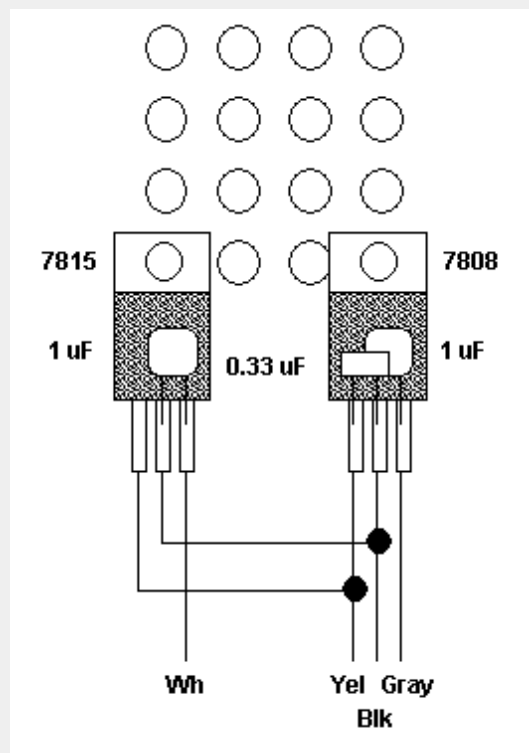

8. The 4-40 small pattern nut just fits between the heat sink fins. Use a thin tool that can hold the nut on the end, and orient the flats of the nut to go between the fins. It's helpful if the parts are magnetic, so you can recover a dropped nut (be sure to cover the holes in the chassis with tissue or a rag). Use a 4-40x3/8" screw to fasten the regulators to the heat sink. The same nuts and screws are used in DB9 and DB25 connector shells. I use some heat sink compound on the back of the regulators. No insulation is required. Check again to be sure the screw for the TO220 pass transistor is tight and the transistor is oriented up so you can get to the terminals.
9. Reconnect the lugs to the backs of the TO3 pass transistors, holding the nuts with log-nose pliers and using a drop of retaining glue or Loctite. Reattach the diode quad to the heat sink.
10. Attach the heat sink to the radio with the middle black screws. Check that there are no wires being pinched between the heat sink and the chassis. Now you can hook up the regulator wires to the terminal strips in the fan case.
11. The resistors to be replaced are inside the power supply fan case. You will notice that the resistors will have lost their color coding from overheating, and the terminal strips may be somewhat charred, from overheating. Cut out the two 82? resistors and their zener diode, and cut out the 22? resistor and its two zener diodes. You can save these in case of trouble, but the new circuit should be more reliable.

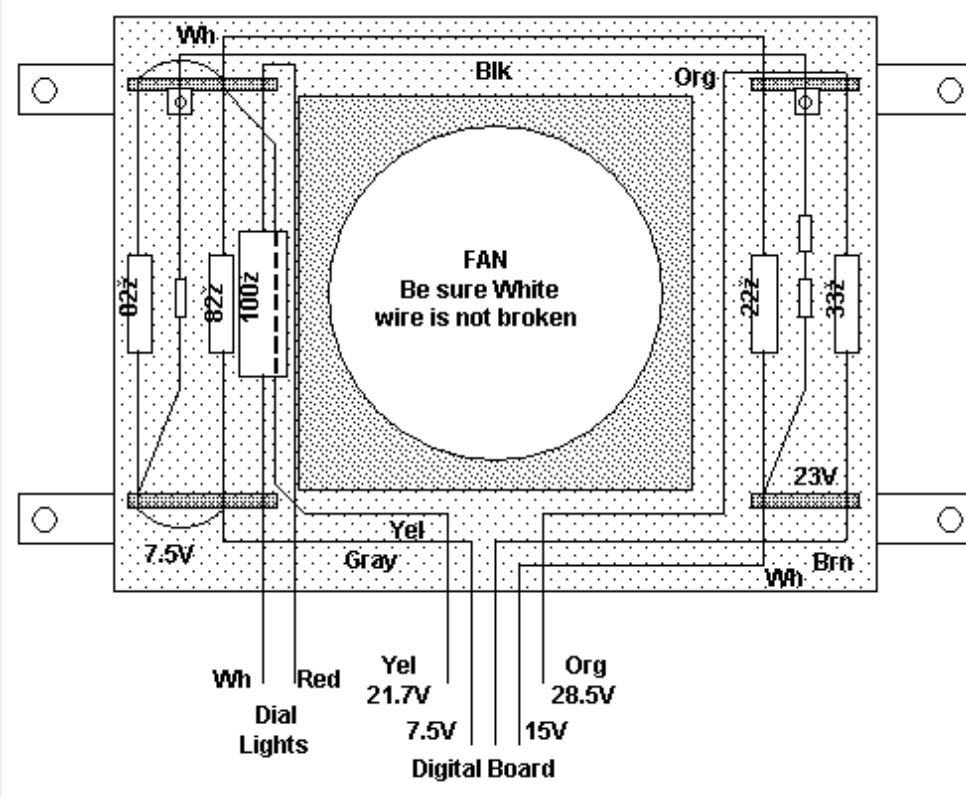

The fan case should now look like this:

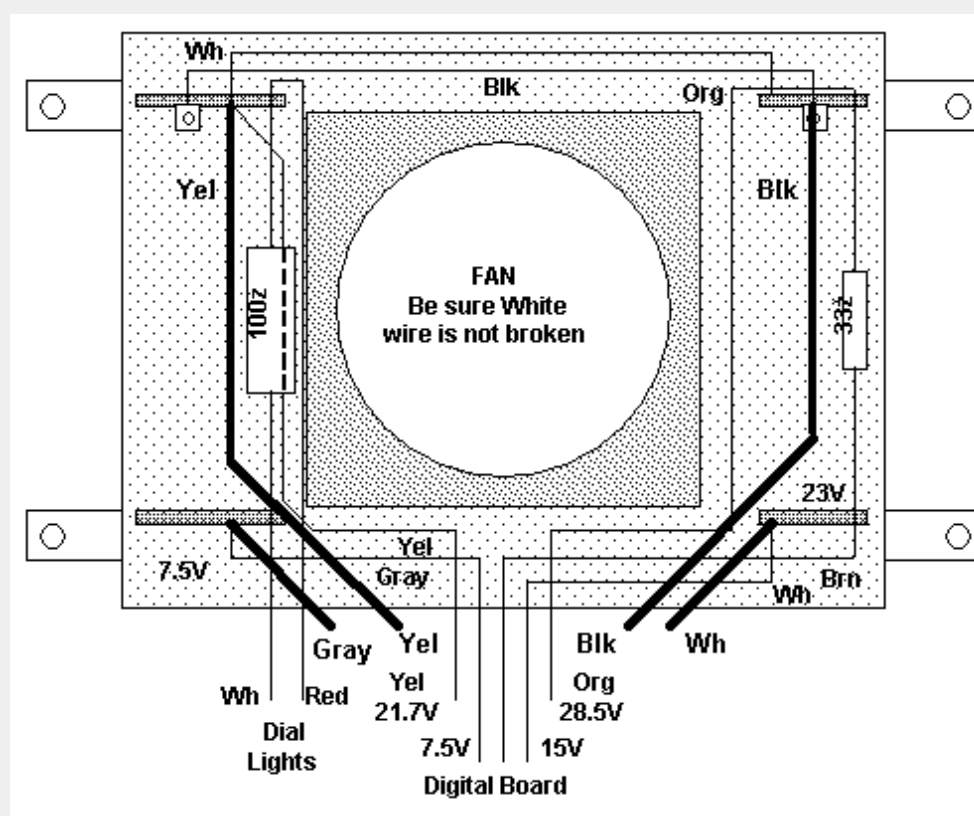

Cut to length and solder the Yellow, Black, Gray and White wires to the terminal strips, making sure they are connected to the same color wire that is already there. Dress the wires in place to avoid the fan with a tiny nonmetallic cable tie or twister.

12. Plug in the radio, being careful of high voltages at the power switch and transformer. Connect a digital voltmeter to radio chassis ground and check the voltages at the terminals in the fan case. Turn the radio power on momentarily to check each of the voltages:

Orange	+28.5
Yellow	+21.7
White	+15
Gray	+8

13. Unplug the radio. If you wish, you can replace the 100ohm resistor with a 5W unit, and the 33ohm resistor with a 3W unit. Using a piece of wire or an oiler, place a drop of oil on the fan shaft. Check to be sure the fan wires aren't broken, and reattach the fan case with the four black screws. Plug the fan back into the power supply board. Replace the top cover and test the radio.

Replacing the 21.7V Pass Transistor

Despite the attention in the literature to the 28.5V TO3 regulators that supply the power amplifier, almost all of our power supply failures have been traced to the 21.7V regulator circuit. As the pass transistor is failing the radio will typically exhibit unusual operation, such as chirpy signal or intermittent display.

The 21.7V regulator is a pair of cascaded emitter followers driven by a 22.5V zener diode fed from the 28.5V supply switched through the power switch. The zener diode D10 and the first transistor Q6 are on the power supply board, and the second transistor Q3 is the TO220 transistor on the heat sink. The schematic incorrectly shows C13 to be 25 uF 100V (it is 100 uF 25V).

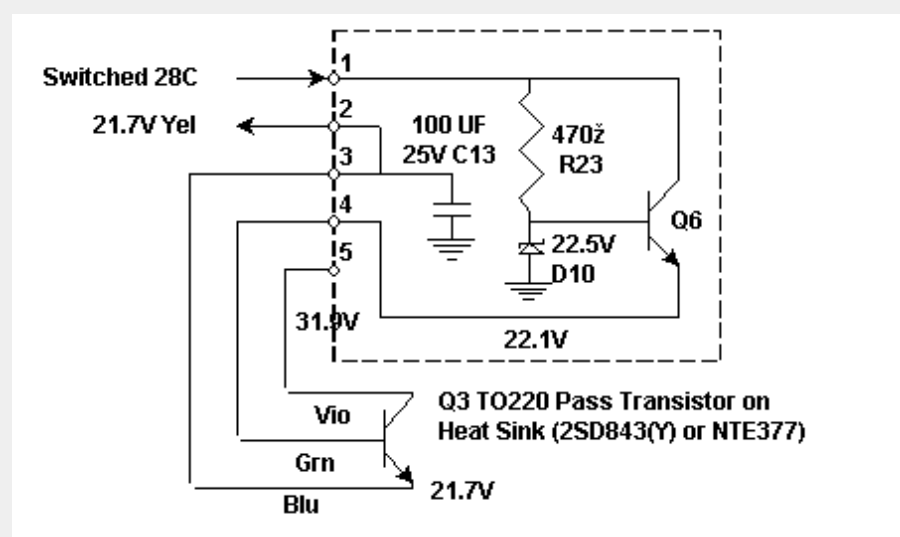

Use an insulated clip probe. If the output of the 21.7V supply measures OK on the yellow wire at the terminal strips in the power supply fan case or the black terminal strip in the narrow space between the output low-pass filter and the antenna tuner, then all is OK.

If the voltage is not correct, it will typically be either 31.9V or near 0V (say, 0.5V). This means the pass transistor Q3 is either shorted or open.

1. Unplug the radio and remove the top cover.
2. Plug in the radio and power on, measure the voltage on the orange wire, either at the top of the power supply board or at the 33ohm resistor in the power supply fan case. It should read 28.5V. If it is OK, the 28V regulator on the board and the pass transistors are OK.
3. Measure the voltage on the yellow wire, either at the power supply fan case terminal strips (you can reach them with an insulated probe in the slot above the heat sink) or at the black terminal strip in the space between the output low-pass filter and the antenna tuner. If it is approximately 21.7V, Q3 and Q6/D10 are OK and the problem, if any, is not in this part of the power supply.
4. If it is not 21.7V, it will typically be either approximately zero volts (0.5V or so) or 31.9V. This means Q3 either has an open or it has a collector-emitter short. Usually, but not always, if Q3 is zapped it will take Q6 and D10 with it. If the voltage isn't right, you need to determine if the problem is Q3 or Q6 or both. With the radio unplugged, unplug the 5-pin connector on the power supply board and use a digital voltmeter with a diode scale to check the Q3 B-C and B-E diodes; also check for a C-E short. Poke a short length of solder into the connector, and use clip-type meter leads. The readings will typically be (assuming the open circuit meter reads 1.4V)

	Pins on 5-pin conn.	Red lead on Base	Black lead on Base
Grn-Blu	2-3	0.7	1.4
Grn-Vio	2-5	0.7	1.4
Blu-Vio	3-5	1.4	1.4

5. If the readings are OK, it is likely that the problem is on the power supply board. If any of these readings is not as expected, Q3 is dead and will have to be replaced (a remote possibility in the case of an open circuited diode is a bad connection at Q3, so check the connector by wiggling it). If Q3 has blown, it may also have taken Q6 and D10 with it. It is worth disconnecting Q3 before removing anything and checking Q6 and D10 to determine if you also need to take out the power supply board. Either unplug the connector at Q3 or cut the three thin wires right at Q3. Be careful not to short anything when measuring voltages, as you will hate yourself if you zap a working circuit while measuring voltages. Reattach the 5-pin connector to the power supply board, plug in the radio and turn it on momentarily to check the voltages on the three wires:

Vio	31.9
Grn	22.3
Blu	0 (with Q3 disconnected, 21.7 in working regulator with Q3 connected)

6. If these voltages are OK, the PS board is OK; unplug the radio and review the data

21.7V OK	Q3 OK	This part of PS is working; check resistors in PS fan case, look for pinched white or gray wires, check 7818 18V regulator on Signal Unit
21.7V bad	Q3 OK	Probably means Q6/D10 bad; remove power supply board and replace
21.7V bad, 22.3V (Q6) OK	Q3 open or short	Replace Q3; Q6/D10 OK
21.7V bad, 22.3V (Q6) bad	Q3 open or short	Replace Q3 and Q6/D10

Replacing Q3

1. To replace Q3, you need to remove the power supply heat sink as in steps 1-6 above. Remove the four black screws holding the fan case onto the heat sink, and unplug the fan wire from the power supply board so it won't break at the fan connection. Free the tab from the case bottom, and tip the case down and put something under it to hold it horizontally to work on. Remove the remaining two black screws holding the power supply heat sink to the radio. You will find the heat sink will not tip out without additional work. Proceed to free the diode quad and the lugs on the TO3 transistors so you can get at the screw that holds Q3.
2. Now you can tip the heat sink forward far enough to be able to reach the screw that holds the pass transistor. If you unplug the pass transistor, be sure to note which way the plug goes on (some have plugs, some have the blue, green and violet leads soldered on and covered with heat shrink tubing, my preference). Remove the pass transistor and replace it with a new one. If the transistor has a gray silicone insulator under it, use it again with the plastic washer to insulate the screw; if it has a mica insulator, use a new one and smear a bit of heat sink compound on both sides before placing it. If there is a connector, plug it onto the transistor now; if you need to solder the wires on, cut the pins on the transistor shorter and use heat shrink tubing on the wires. In some radios, I've found this screw was not tight so be sure it is snug when you are finished so the transistor won't overheat and fail.

If you are going to replace the resistors with regulators, now is the time to do it while the heat sink is accessible. Also, if Q6/D10 are to be replaced, it's easier to do with the heat sink out of the way.

3. Reconnect the lugs to the backs of the TO3 pass transistors, holding the nuts with long-nose pliers and using a drop of retaining glue or Loctite. Reattach the diode quad to the heat sink.
4. Attach the heat sink to the radio with the middle black screws. Check that there are no wires being pinched between the heat sink and the chassis. Clean, oil and replace the fan.

Replacing Q6 and D10

1. You can check Q6 for a collector-emitter short by measuring from pins 1-4 of the 5-pin connector (should show an open with both polarities), but you can't measure all the junctions. If you need to replace Q6 or D10, you will need to remove the power supply board. Make a sketch of where all the connectors and wires go. If both Q3 and Q6 are blown and you have the heat sink open, do the power supply board repair before reinstalling the heat sink. The power supply board can be removed without removing the heat sink, but it is more convenient to do it before you reinstall the heat sink if you have replaced Q3.

Unplug the inline bayonet connector in the red wire to the power amplifier. Unsolder the heavy yellow and white wires from terminal 28A. Unsolder the orange wires from 28B. Unsolder the black ground wires from the ground terminal. These terminals are at the top of the power supply board. Wear safety glasses so you don't flick solder in your eye, and use a solder suction pump to remove excess solder. Typically, the lugs will come unsoldered from the circuit board, but it is easy to put them back straight after the wires are unsoldered.

2. Unplug all the connectors, noting which goes where. Now remove the two screws that hold the bracket to the chassis, using a magnet (a necessary tool for any of these jobs) to reclaim them so they don't roll down a hole into the space under the signal board (it's a big job to remove and replace it). Lift out the power supply board.
3. Remove the power supply board from the bracket by removing the four screws at the corners. Now you can locate Q6 and D10. Once you have gone this far, you might as well replace both, since it takes a separate setup to measure the zener, and the transistor is easy enough to change out. Use a solder suction pump and observe the polarity of the zener and the connections of the proper leads. After the old transistor is removed, you can check the junctions using the digital multimeter. I'd add a 47 ohm current-limiting resistor in series with the collector of Q6.
4. Replace the power supply board by reattaching it to the bracket, then reattaching the bracket to the chassis. Be careful not to pinch under the bracket any of the wires coming from the fan case or the back of the chassis. Plug in all the connectors. Resolder the black wires to the ground terminal, the orange wires to the 28B lug and the yellow and white wires to the 28A lug. Make sure the lugs are well-soldered to the circuit traces. Plug in the red wire to the power amplifier.
5. Before you power up, check with an ohm-meter from the orange (28.5V) and yellow wires (21.7V) to be sure there are no shorts. You should see capacitors charging up in either case. If there is a short, check carefully for a pinched wire under the power supply board. If this measurement shows no shorts, plug in the radio and power on, measuring the voltages on the orange and yellow wires (you can reach the yellow wire terminal in the fan case with a well-insulated probe). The voltages should be

Orange	28.5
Yellow	21.7

If OK, you are done and can replace the heat sink, fan cover and case top. The 21.7 voltage has no effect on any critical adjustments, so no realignment is required.

Fan Operation Check or Repair

Check the operation of the 12V Power Supply fan and the 12V Power Amplifier fan by running into antenna or dummy load at 50W as follows:

Mode: TUNE
Send/Rec: SEND
Car: Midscale on meter
Power: 50W

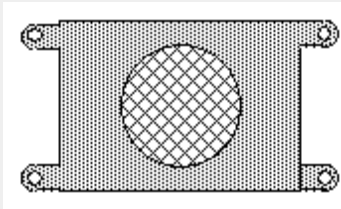

After a few moments both fans should start up. In any event, proceed to refurbish as follows:

- Unplug radio
- Remove 4 black screws holding metal tabs top and bottom of fan box.
- Tip PS fan assembly back, rotating around wires at bottom (pull some slack in the black fan wire from radio so the weight of the fan motor won't break the connection to the fan))
- Fan blades should spin freely when turned by hand, with the lumpy feeling of a DC motor
- Check for mechanical interference with fan blades, for example by fan screen; correct if found
- Fan white wire should read about 60 Ω to ground, and black wire should connect to ground; if motor reads open the fan is doomed and will need to be replaced
- Remove 4 silver screws on outside of fan box to remove fan motor assembly
- While fan is out, remove screen and reshape it to bow out enough to ensure clearance
- Place a drop of WD-40 or light oil on the bronze bearing where the shaft goes through, spin shaft
- Check for mechanical interference; on later serial number radios there is a small flat spring wiping the motor shaft under the fan hub to quiet the motor, don't damage it
- Being careful not to crush any wires, replace the four silver screws to fasten fan to box; make sure no wires rub the fan blades; look in holes and rotate the screen to get openings for the four screws
- Test fan by plugging in radio, run 50W transmit test with antenna or dummy load; fan should start and run quietly if motor measured good. Voltage on fan should be 10 to 12 VDC when PS is hot
- Some have suggested wiring the fan to run continuously through a diode from the +8V available in the fan case, but this has not proven necessary with the power supply modification to remove the shunt regulators, as the heat sink runs noticeably cooler after the mod

Once PS fan is working, clean and oil the Power Amp fan, which comes straight out after four mounting screws and washers are removed.

If a either fan is beyond repair, substitute a replacement or an 80x25mm 12V computer muffin fan. New holes are needed for the mounting screws, which are 2.81" on centers (the existing holes are 2.45" on centers). Wire the red fan wire to the white supply wire, and the black fan wire to the black supply wire.

Lubricating the Top Cover Door

The sliding door in the top cover becomes very difficult to move after some years of service. Any time you have removed the top cover, lubricate the sliding door in the top with Silicone liquid or grease lubricant on the plastic slides. Press down one edge, hold in place with screwdriver, wet the corner of piece of paper with Silicone spray, run it between the door and the lid, do same all around and also between black plastic and door. This is much easier to do while the cover is off. Be careful of the line voltage on the POWER switch on the front panel, and don't short anything around the power supply voltage regulator. Do not use a petroleum-based lubricant such as WD-40 on plastic parts, as they will swell and deteriorate.

Line Voltage Change to 240V

Because of low line voltage and neutral wire problems, our 120V line voltage ranged from 106 to 113V, causing hum when the regulators dropped out of regulation. Attempts to rewire the transformer for 100V operation with low line voltage (below 110V with load) resulted in overheating of the power supply, since with such a large change (20%) the unregulated voltages rise above the design limits.

If the 120V line voltage is low, use the 240 or 220 volt switch position.

- Replace the 6A fuse with a 4A fuse; retain the 6A fuse if it is desired to change back later
- Turn the switch on the bottom of the radio to 240V, or 220V if the voltage is low
- Plug in special yellow 240V line cord, attach to rear panel so it won't be used on a 120V radio

- Plug into a 240V outlet or extension cord (surge absorber preferred, make sure ground is OK)

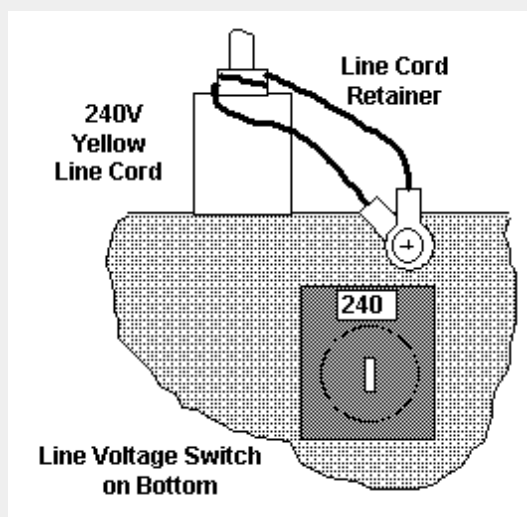

Cleaning Signal Unit Connectors with Contact Cleaner

On several occasions receivers have suddenly lost sensitivity for extended periods, and other radios have had sudden complete interruptions of microphone input. While there can be other causes for these intermittent failures, they were in each case traced to the connectors at the Signal Unit. In all cases the intermittent behavior was eliminated by cleaning the contacts of the connectors in the particular signal path.

The idea developed that this reliability issue was due to corrosion of the connectors on the Signal Unit. It was decided to clean all of the connectors to avoid any recurrence of the intermittent problems, a course which has been successful. In some cases it was possible to observe discoloration of the connectors that was possibly indicative of corrosion.

I remove each and every connector, one by one, and spray or dab the pins with contact cleaner, then rub the connector in and out a couple of times. I do all the connectors, including the filter connectors and especially the microphone and coaxial RF connectors. This has solved several complaints of intermittent or deaf radio or no transmit audio on SSB. The intermittent problems went away.

After I did this, I learned from several other TS-930 users that they had experienced the same problems, and had resolved them in essentially the same way.

AGC Modification with Germanium Diode

An AGC modification results in a big improvement in the ability to copy signals in the S9 to S9+20 range. This modification prevents the AGC overshoot that blanks the first character of a loud CW signal, with no bad side effects. A germanium diode is placed across D125 under the CW 455 kHz filter, with the "bar" end toward the rear of the radio (opposite to the bar on D125). The new diode is soldered across D125, which is located under the large 455 kHz 500 Hz IF filter.

- Unplug radio
- Turn radio upside down and remove bottom cover (8 screws, including the ones that hold the top cover at the sides).
- Locate the 500 Hz 455 kHz crystal filter (the largest one, on your right as you face the bottom of the radio from the panel end), lift out harness, remove screw at each end and lift it out.
- Underneath you will see R375 and D125; solder the Germanium diode across D125 as shown.

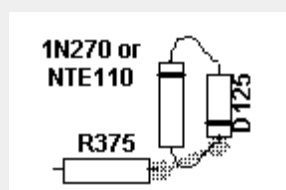

- Replace IF filter, being careful not to damage connectors; push the connectors down tight before you replace the screws. Put a label "R375+1N270" on the filter to show the AGC mod.
- Test the radio before you replace the bottom cover; watch out for line voltage at the back and behind the POWER switch on the panel.
- Before you replace the bottom cover, you should also clean the connectors on the Signal Unit.

Alignment with Non-contacting Pickup for Oscillator Frequencies

In some cases it is desired to check or adjust the transceiver alignment while not having access to formal test instruments, and without opening the radio and exposing the circuits to possible damage through connecting test leads. Use an insulated wire as a pickup antenna by pushing an insulated loop through the appropriate tuning hole in the bottom (or side cover in the case of the 20

MHz master reference oscillator). A second radio can be used to measure the frequency to the accuracy required.

The first step should be to check the accuracy of the reference oscillator. I connected a small outdoor antenna wire to an insulated loop pushed into the side cover opening for the oscillator adjustment, with the other end of the loop connected to the antenna connector on the radio. With this setup, monitor the 20 MHz signal of WWV and adjust the insertion of the loop for somewhat equal signals from the external standard and the signal from the internal oscillator. You will be able to hear the beat note and adjust the oscillator for zero offset from the standard frequency. Let the radio warm up for 30 minutes or so to be sure everything has stabilized.

As another example, consider the alignment of the Carrier-2 oscillator used to provide variable bandwidth. The variable bandwidth tuning (VBT) uses two IF filters, one at 8830 kHz and the other at 455 kHz. The conversion oscillator at 8375 kHz determines the degree of overlap of the filter passbands. If the VBT knobs are set to widest position, the conversion oscillator should be at exactly 8375.0 kHz.

This can be done by connecting a counter (for example, an antenna impedance bridge counter) through a DC-isolated probe to C298 of the signal board, but if there's no other work to be done leave the case closed and use an insulated wire loop poked into the hole as an antenna to hear the oscillator on a second radio.

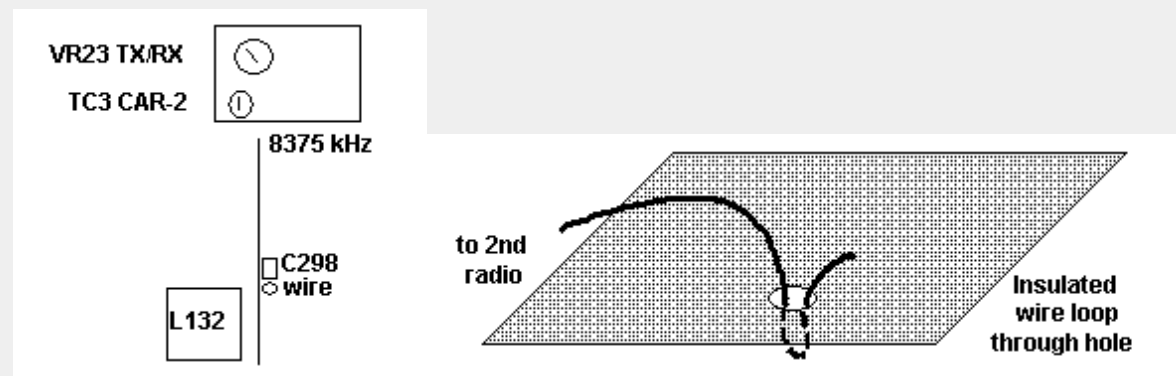

The radio should be set up (see Service Manual, pg. 67, adjustment and test points are on pg. 77)

Mode: USB
Transmit: REC
VBT: CW, High Cut fully CW, Low Cut fully CCW (no narrowing)

- Measure the frequency at 8375 kHz
- Adjust VR23 so there is no change in frequency from transmit to receive
- Adjust TC3, the small trimmer capacitor, so the frequency is exactly 8375.0 kHz

At this time you should also check the carrier oscillator at 8830 kHz

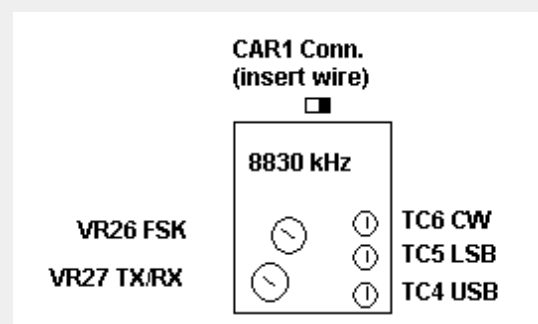

The radio should be set up (see Service Manual, pg. 66, adjustment and test points are on pg. 77)

Mode: USB
Transmit: REC
VBT: CW, High fully CW, Low fully CCW

- Measure the oscillator frequency, which should be 8831.5 kHz.
- Adjust VR27 so there is no change in frequency from transmit to receive
- Set TC4 so the frequency is 8831.5 (I prefer 8831.6, you can go by the sound of the receiver audio to get the upper and lower signal levels equal, at +300 and +2.9 kHz).

Now switch to LSB, and set TC5 for 8828.5 kHz. Switch back and forth between USB and LSB, and trim the LSB oscillator until the noise sounds the same. Then switch to CW and NARROW, set TC6 for 8830.0 kHz. Last, connect a dummy load or antenna and switch to FSK transmit and set VR26 for 8827.79 kHz.

Last, check the setting of the CW Pitch and the Notch. Turn on the Marker oscillator, put the rig in CW mode, and check to see that the pitch covers the desired range. I set the CW Pitch so it is zero beat with the knob at 12 O'clock, so you can tune either sideband. The CW Pitch is set by L173 at the far right rear of the Signal Unit (bottom of rig). While you have a received tone, check the Notch by pushing in the NOTCH button and tuning the control for a null. With the offset tone at 1.5 kHz, the null should be at 12 O'clock. If it's not close, adjust L167 on the Signal Unit.

Don't forget to set Moni, Sidetone and other adjustments (AGC Delay, for example) before the radio is stuck under a shelf or cabled in

place.

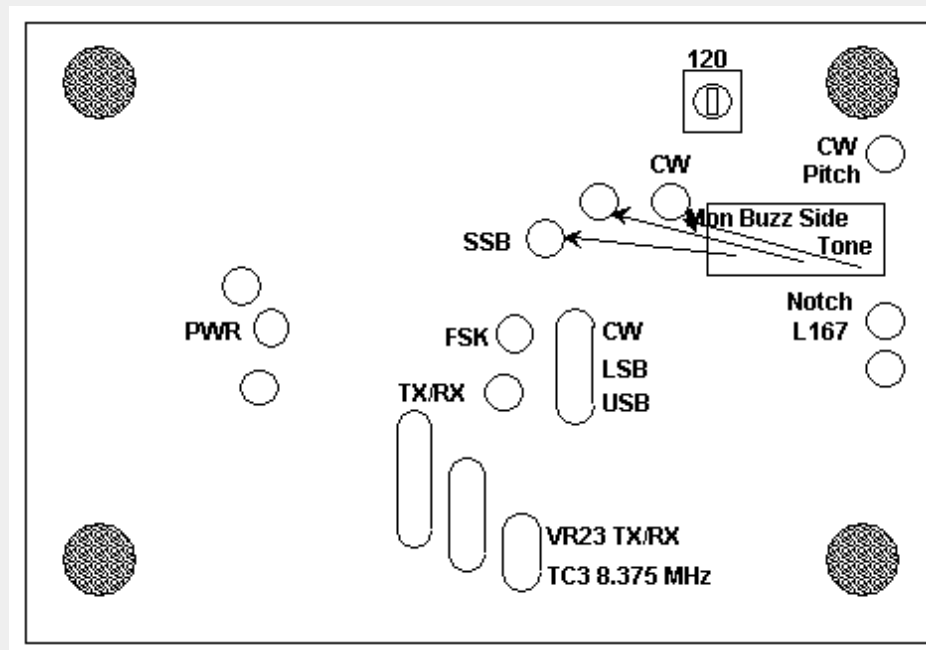

A Note on Alignment Levels

Clif Holland of Avvid, a respected repairer of Kenwood radios, emailed me to note that the Japanese specification for the standard signal generator used in alignment is different from the US signal generator calibration. The 930 service manual refers to signal levels in dBuV, so I had assumed 0dBuV was 1 uV and 40dBuV was 100uV.

But not so. Clif is right and I'm off by 6 dB. I checked it out, and although I see no mention of the issue in the TS-930 or TS-950 manuals, I found a table in the TS-850 service manual, pg. 96, that confirms this. It has two columns:

Japanese "SG"	American "SG"
-6dB	0.25uV
0dB	0.5uV
6dB	1uV... etc.
40dB	50uV... etc.

Apparently the JA generator defines output in terms of open circuit voltage rather than voltage into a matched load. This 6 dB difference affects the alignment of the RF PIN attenuator start point as well as the S-meter settings for S1 and S9. Since the manual specs are ± 4 dB anyway the difference will be mighty small except for a more active S-meter.

CW Reception on USB

To listen on USB on a 930 in CW mode, adjust the "CW Pitch" (BFO) coil L-173 (yellow core, farthest right-rear on bottom, there's a hole) so you have zero-beat at center position (12 o'clock) on the CW PITCH control on the front panel. If measuring frequency of this oscillator, this yields 100.0 kHz rather than 99.2 kHz.

Now if you turn the pitch control clockwise from center you get LSB as before, but if you turn the pitch control CCW from center you get USB. No retuning of filters or carrier oscillators is required. This mod has no effect on SSB.

I use this on our TS-930s at HC8. The only problems are that it makes the TUNE mode zero-beat if the pitch knob is centered, and also if an op isn't familiar with the setup on CW it can be concluded that the receiver is not working if the pitch knob is centered.

Operating Notes

I found it's difficult to tighten the nut on the Antenna UHF connector. Lacking a special spanner, you can carefully tap the Antenna connector nut with screwdriver and small hammer, as with the nuts in electric boxes. Don't overdo it.

For use with an external receiving antenna, one needs the hard-to-find 262 degree 8-pin "horseshoe" DIN-8 connector used to bring a separate receiving antenna in and out of the transverter socket (available from Kenwood and Yaesu, and HRO, but seldom found when needed). In an emergency we found that a standard DIN-5 connector will plug in and provide access to the receiver input and ground, while the small slide switch makes the transmit antenna output available at the adjacent RCA phono connector to connect to an receive-antenna selector switch (inadvertent mis-setting of this switch is a source of occasional complaints of deaf receiver).

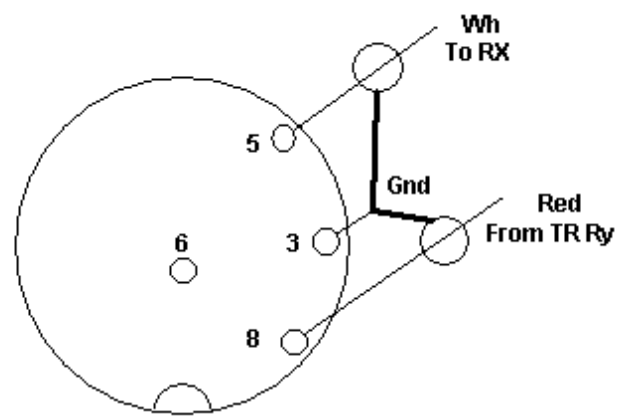

From back of connector P/N E07-0851-05
Special Kenwood part
DIN-8 262° (not 270°)

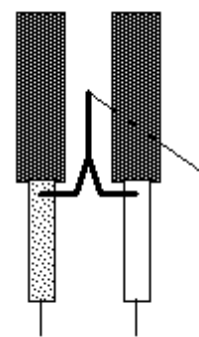

RCA Connector
Cable Detail

Twist braid,
solder to flexible wire,
cover with heat shrink

It's good practice to have a relay that disconnects the receiver input from any antenna and shorts it to ground during transmit, so the transmit power isn't returned to the receiver from a separate receiving antenna. When used as a second receiver in a multi-op setup, this relay can also be run by the AMP relay line of the transmitter on the same band.

We don't use the noisy and slow amplifier relay (28V to NC pin), but make a transistor switch adapter in the DIN-7 plug for the PTT input and AMP output. This is faster, less noisy and more reliable. With the AL-1200s we use the speedup circuit found on K6XX's web site.

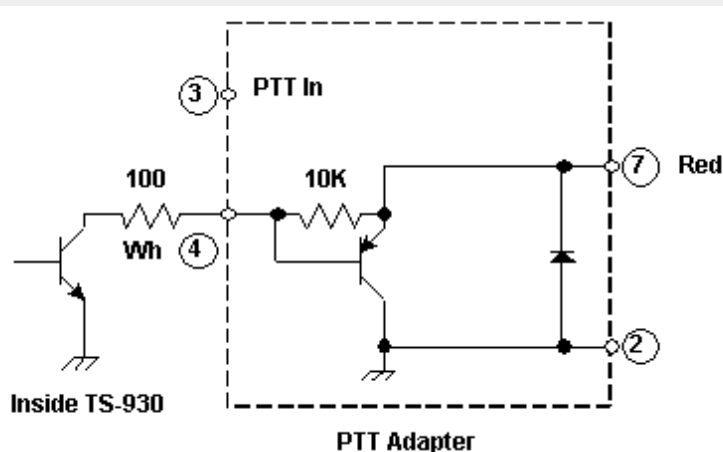

Inside TS-930

PTT Adapter

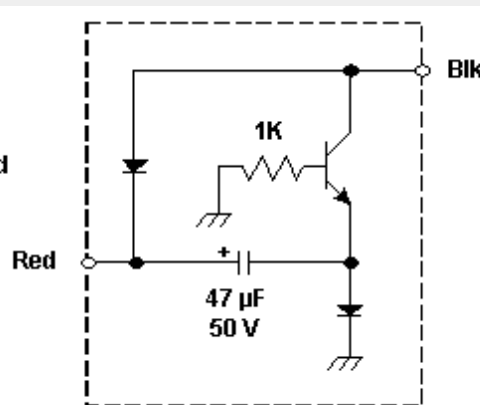

Amp Relay Speedup

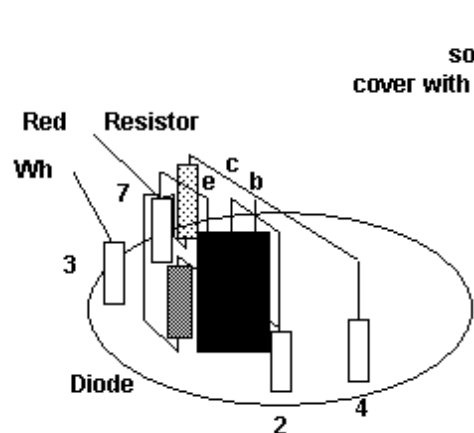

Twist braid,
solder to flex wire,
cover with red heat shrink

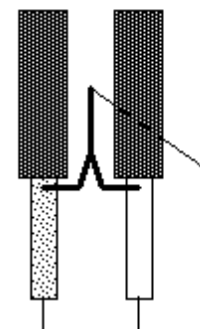

RCA Connector
Cable Detail

Naturally, we've had to cure hum and RF problems when using two radios and a microphone switch box along with a voice recorder, but this has been resolved by using double shielded twisted pair but not connecting the shields at both ends except through RF bypass capacitors. I have a circuit, based on K8CC's in the NA manual, that works very well for me. There are some curious audio/brain effects I've read about in a Bell Labs book on hearing and sound that are interesting to experiment with, including wiring headphones for out-of-phase reception.

One remaining problem is RF leakage of the display waveforms on the band-select cable from the PIEXX board. It appears this should be shielded. With the removal of the resistors in the PS fan case there is now room for some real back-panel connectors, DB9(F) for the RS-232 connection and DB25(F) for the band data. I cut off the unneeded wires in the RJ45 connector to avoid any problem with the PIEXX board.

References

There are a number of sources of two text files listing mods and fixes for the early TS-930. <http://www.qrz.com/download/mods-tz/ts930.txt> is an updated version of a posting by WA2ISE called "TS930 repair notes (long)." There are many other sources of this document, to be found with any search engine under "ts-930 mods" or the like. The newest version notes that replacement dial light

bulbs should be 28v @ 40mA, not 12V, and that the part number for these bulbs is not correct in the service manual, and should be B30 0826 05.

http://www.artofhacking.com/Tucops/Radio/two_way/TS930.TXT is one source of a different document that is "a list of favorite changes that can be made to the Kenwood 930."

<http://www.kkn.net/~k5tr/ts930fix/ts930doc.pdf> is the source of a definitive service bulletin from TRIO-KENWOOD GMBH about "Digital Unit through-plated hole defects and their symptoms." The PDF was created by K5TR from a MS word doc from NØSS.

<http://www.qth.net/archive/kenwood/>, the Kenwood mailing list archive, is a great source of information, but is not indexed by subject.

I haven't been able to find a good reference for the idea of replacing R400 of the Signal Unit with a 7912 TO220 regulator (mounted on the heat sink at the back of the Signal Unit). If I were to do this, I'd clip one lead of the 12V zener diode D210.

Using the current-limit feature of the 723 regulator chip, some have built a protective crowbar circuit to keep the 28.5V from damaging the amplifier transistors by running away if the regulators fail. It is the same as the 28V supply circuit in the 1988 ARRL Handbook, and I haven't felt it necessary (yet). ZL2DX emailed me a copy of a 1992 circuit by NJ6O from the Kenwood/IRCI newsletter, now be available through W2VJN at <http://www.qth.com/inrad/pubs.htm>.

Replacement Semiconductors

Although there are many sources of the original transistors, it has proven convenient and reliable to use the current replacement semiconductors offered in the US by NTE. Here is a list of suitable replacements:

2SD843(Y) NTE377
2SC2235(O) NTE382
XZ-225 NTE5080A
2N5885 NTE181
MRF485 (2) NTE236 (2)
2SC496(Y) NTE295
2SB861(C) NTE398
2SC1815(Y) NTE85

I've looked in vain for a TO220 power transistor that does not require the insulated mounting, but have not found one that has low enough thermal impedance and high enough current and power ratings. I've seen a suggestion to replace the 22V emitter follower with a 7824, but this might sacrifice the control by the switched 28.5V. I select from the NTE5058A (nominally 22V) individual zeners that provide 22.5 volts; the lead length of mounting to the circuit board affects the voltage, which rises with the operating temperature of the diode. If I measure them in free air with clip leads, I get a higher voltage reading because they get a lot hotter after a moment's operation.

I was surprised to be able to make a successful replacement of the expensive but burned out MRF485 RF driver transistors (don't ask!) with the relatively inexpensive NTE236. I made no effort to match the NTE replacements, and the amplifier seems to work fine; I reset the bias adjustment per the instructions in the service manual.

I was concerned about the thermal impedance of the replacement TO3 transistors NTE181, which also have relatively low current gain, but a matched pair (NTE offers these designated as NTE181MP) was used with success to replace a pair of defunct 2N5885 28.5V regulators.

Kenwood Service Bulletin Reference

TS-930S	ASB-0863	INCORRECT LINE VOLTAGE SETTING
TS-930S	ASB-0866	CW HETERODYNE TONE WITH VBT CONTROL
TS-930S	ASB-0867	SSB TX AUDIO TONE QUALITY SN < 3080001
TS-930S	ASB-0868	LOSS OF RX SENSITIVITY
TS-930S	ASB-0869	PLL UNLOCK / BLANK DISPLAY
TS-930S	ASB-0872	CW PITCH TONE SHIFT WHEN MONI SWITCH IS ON
TS-930S	ASB-0873	CW VBT - SIMPLIFIED ALIGNMENT
TS-930S	ASB-0874	RF FEEDBACK WHEN USING EXTERNAL SPEAKER
TS-930S	ASB-0875	RX AUDIO OSCILLATION
TS-930S	ASB-0876	RF FEEDBACK INTO MIC CIRCUIT
TS-930S	ASB-0879	ALC LEVEL DRIFT AT 28 MHZ
TS-930S	ASB-0881	POWER SUPPLY SURGE PROTECTION
TS-930S	ASB-0884	15 MTR INTERNAL BEAT NOTE
TS-930S	ASB-0886	INTERMITTENT TX POWER OUTPUT
TS-930S	ASB-0893	NOISY POWER SUPPLY FAN

<ftp://216.98.255.24/Amateur/AmateurServiceBulletins/>

19-07-1998**(TS-940) TS-940S LCD Clock Display Erratic Operation**

We have received a few reports concerning erratic operation of the LCD clock display when the Main dial is rotated, or the VBT or SLOPE TUNE controls are operated. This appears as if you had pressed the SET, SCROLL, or GRAPH switches.

This erratic operation may be caused by improper timing of the input pulses applied to the auxiliary display microprocessor, IC1.

1. This symptom is easily corrected by replacing IC2 MBM2764-30T1 with MBM2764-30T2, on Digital Unit A. Early models of the improved IC will carry the old nomenclature but will be distinguished by a white dot on the top of the chip.
2. After the IC has been changed reset the main microprocessor by pressing and holding the A=B key, and then turning the power switch OFF and then back ON. Then release the A=B key.
3. After this change is made the sub-display will not immediately track the main display. A slight delay has been introduced into the new IC to prevent any timing errors. It may take approximately 0.5 seconds for the LCD to track the main display.
4. Please return the old IC2 to the Service Department along with the WSR for Credit.

Perform this modification only if the symptom occurs, as a repair. This change is not required otherwise.

Time required for this modification is 1 hour or less.

19-07-1998**(TS-940) TS-940S SSB Talk Power Improvement**

Author: Trio-Kenwood Communication, inc.

Service Bulletin no. 921 (22-7-1987)

TS-940S's in the serial number range of 601XXXX through 708XXXX may be limited in SSB peak power as compared to full CW output. The level may be increased by changing the value of capacitors C182 and C183 in the ALC circuit on the Control board. The recommended replacement value for each capacitor is 0.0022 uF, 50v (CK45B1H222K).

Procedure:

1. Disconnect the power cord and antenna from the transceiver.
2. Remove the top and bottom covers (16 screws).
3. Locate the Control board on the bottom of the transceiver.
4. Locate transistor Q37 on the board (toward the back right hand side.) The two capacitors are mounted on the foil side of the board underneath Q37.
5. To access the bottom of the board remove the 8 screws that mount the board and heat sink to the chassis (See figure 1.)
6. Carefully lift the board/heat sink from the right hand side and pivot it toward the front of the transceiver.
7. Replace C182 and C183 with 0.0022 uf, 50v capacitors.
8. Lower the board back into its original position (don't pinch any wires!) and re-install the 8 mounting screws.
9. Put the covers back on the TS-940S and secure them with the 16 case screws.
10. Connect the antenna and power cord then test the transceiver for normal operation.

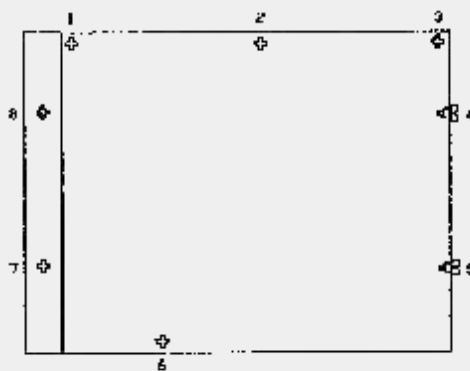

FIGURE 1

C182,183 -

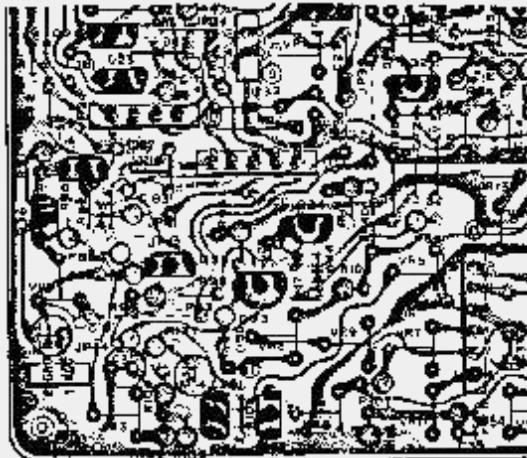
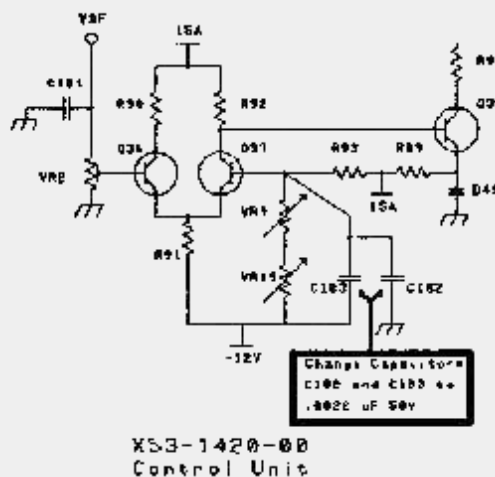

FIGURE 2



This is an optional change and may not be performed under warranty.
Time required for this change is 1 hour or less.

This modification is read 1666 times.

[top of page](#)

19-07-1998

(TS-940) TS-940S Erratic display

Author: Trio-Kenwood Communication, inc.

Service Bulletin no. 951 (20-1-1989)

Intermittent control or display problems that are difficult to correct with the reset procedure may be caused by a faulty ROM socket. The socket should be checked to insure that it makes good electrical contact with each pin of the ROM. If it is found to be intermittent, remove the socket and solder the ROM directly to the board. It should be noted that units between serial numbers 701XXXX to 811XXXX and from 903XXXX to 909XXXX are not likely to have this failure. In addition, units with a serial number of 909XXXX and above do not incorporate a socket.

CAUTION

Removing the socket requires good soldering skills. The ROM is mounted on the Digital A unit and is designated as IC2. The board, being double sided, has solder connections on both component and foil sides. When the socket is removed, it is very important to insure that each pin is completely solder free. Having to pry up on the socket means that it is not completely desoldered and will cause the circuit foils to tear.

When performing any work on the Digital A board, CMOS handling techniques must be observed. Such techniques include using a grounded or isolated soldering tip, avoid touching the pins of IC chips with your fingers, and ground yourself with a wrist ground strap.

To remove the socket:

1. Disconnect the power cord and antenna coax.
2. Remove the top and bottom covers from the transceiver.
3. Remove the 2 flat head screws from each side of the front panel chassis.
4. Loosen the round head screw on each side of the front panel chassis.
5. Carefully rotate the front panel forward. It will be necessary to unplug the VS-1 cable from the transceiver.
6. Remove the 4 screws from the speaker mount.
7. Carefully pull up on the mount and rotate it toward the front panel. Swing the mount toward the right side of the transceiver and allow it to rest on the Digital B unit shield.
8. Remove the 8 screws from the Digital A unit shield plate.
9. Lift the plate and rotate it to the left side of the transceiver.
10. While avoiding contact with the pins, remove the ROM (IC2) and set it aside on anti-static foam.
11. Remove the 6 screws that mount the Digital A board. Rotate the board toward the front panel to expose the bottom side of the board.
12. Carefully desolder the socket and remove it from the board. Do not pry up on the socket. If it does not easily pull off the board, the top foils are still soldered to the socket.
13. Install the ROM in the board and solder it in place.
14. Assemble the transceiver by reversing steps 1 - 11. Do not pinch the power switch cables between the front panel and the body of the transceiver.

Time required for this modification is 1.5 hrs or less.

This modification is read 1411 times.

[top of page](#)

19-07-1998

(TS-940) RX AUDIO

1. On Kenwood TS-904's that do not have the optional Voice Synthesizer module VS-1 installed, you may notice a hum in the RX audio. The already present molex connected cable for this module should be dressed to the top of the shield case where the voice synthesizer mounts. However, on some units they have been left hanging free in the vicinity of the PLL and digital A units and are quite good at picking up noise from these circuits.
2. The Fix, is simply to secure this cable to the top of the shield case where the VS-1 would mount. Plastic tie straps, or even simple electrical tape works very nicely.

This modification is read 1497 times.

[top of page](#)

19-07-1998

(TS-940) Amtor switching time

1. Most stock TS-940S' require 30 to 50 mS to switch back from TX to RX. This can be reduced to less than 20 mS by cutting the center lead of Transistor Q68 on the Control Unit PCB.
2. After the modification, a slight "click" will be heard in the speaker during switching. However, this is no big deal to the AMTOR nut because of the improved switching time.

This modification is read 1187 times.

[top of page](#)

19-07-1998

(TS-940) ALC time constant

1. This Mod will change the TS-940 time constant from approximately 1 second to .022 second. This means that the ALC will no longer impose its own characteristics on your audio response; the ALC will now follow your own syllabic rate and emphasis. Usually the average output will increase, which will drive a linear amplifier harder (or at least those meters will swing higher!!). Use caution in this mod and have another Ham-friend check around your TX frequency for splattering while you are QRV.
2. The TS-940 has a 10uF cap (C31) and 100K resistor (R104) which make up the time constant for the ALC. This tends to reduce the output power for the duration of the ALC time constant (or till the circuit charges up again). Then it starts all over again on the next word.
3. This procedure allows modification to the control PCB (X53-1420-11) in the TS-940 WITHOUT having to remove the board. Remove the bottom cover and locate the control PCB. Locate R137 and R104. These are located in the upper right hand corner as the rig faces you upside down (near VR-3). A service manual is helpful for locating parts!!! Using an Exacto knife, VERY CAREFULLY scrape off some insulation from the top of these two resistors. Now tack-solder a 1/8 watt 2.2k ohm resistor from the top of one of these resistors to the top of the other. The time constant is now changed. Reassemble and enjoy a superb rig.

This modification is read 1272 times.

[top of page](#)

19-07-1998

(TS-940) TS-940 Mod for MARS and all band operations

Locate IC number 109.
Now find diode 130 and cut it for all-band transmit.

If you want just MARS coverage, locate IC 111 and 112, and snip diode 135 beside it.

This modification is read 1815 times.

[top of page](#)

15-04-2000

(TS-940) TS-940S PLL unlock

Author: Trio-Kenwood Communication, inc.

Service Bulletin no. 900 (18-10-1985)

Some users of the TS-940S have reported a blanking of the display accompanied by a loss of transmit and receive. Readjustment of the PLL unit will correct this tendency.

Procedure:

1. Set the Dial frequency for approximately 1.8 MHz (inside the band).
2. Using an RF probe at TP5 adjust L22, L23, and L24 for a maximum reading on the meter. You should see approximately 250 mV.
3. Adjustment of L24 will produce the greatest change, which may be up to a 90° adjustment from its present position.

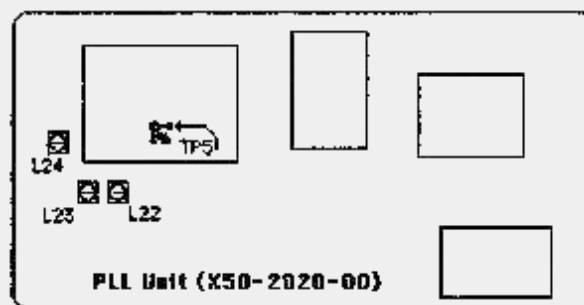

Time required for the procedure is .5 hour or less.

This modification is read 1430 times.

[top of page](#)

(TS-940) TS-940S Antenna Tuner Relays

Author: Trio-Kenwood Communication, inc.

Service Bulletin no. 907 (4-4-1986)

Occasionally during operation of the AT-940 a VSWR greater than 1.5 to 1 might cause overloading of the relay contacts in the antenna tuner. This may be especially noticeable when switching BANDS, or if TUNING is performed too frequently. The following procedure should reduce or eliminate the tendency.

Parts Required

Q69: Digital transistor, (DTC124ES)

R304: 5,6 Kohm 1/6 Watt Resistor, (RD14BB2C562J)

Procedure:

1. Add the circuit as shown below.
2. After the circuit has been installed adjust VR4 for a 10-15 watt output when the antenna tuner operates.

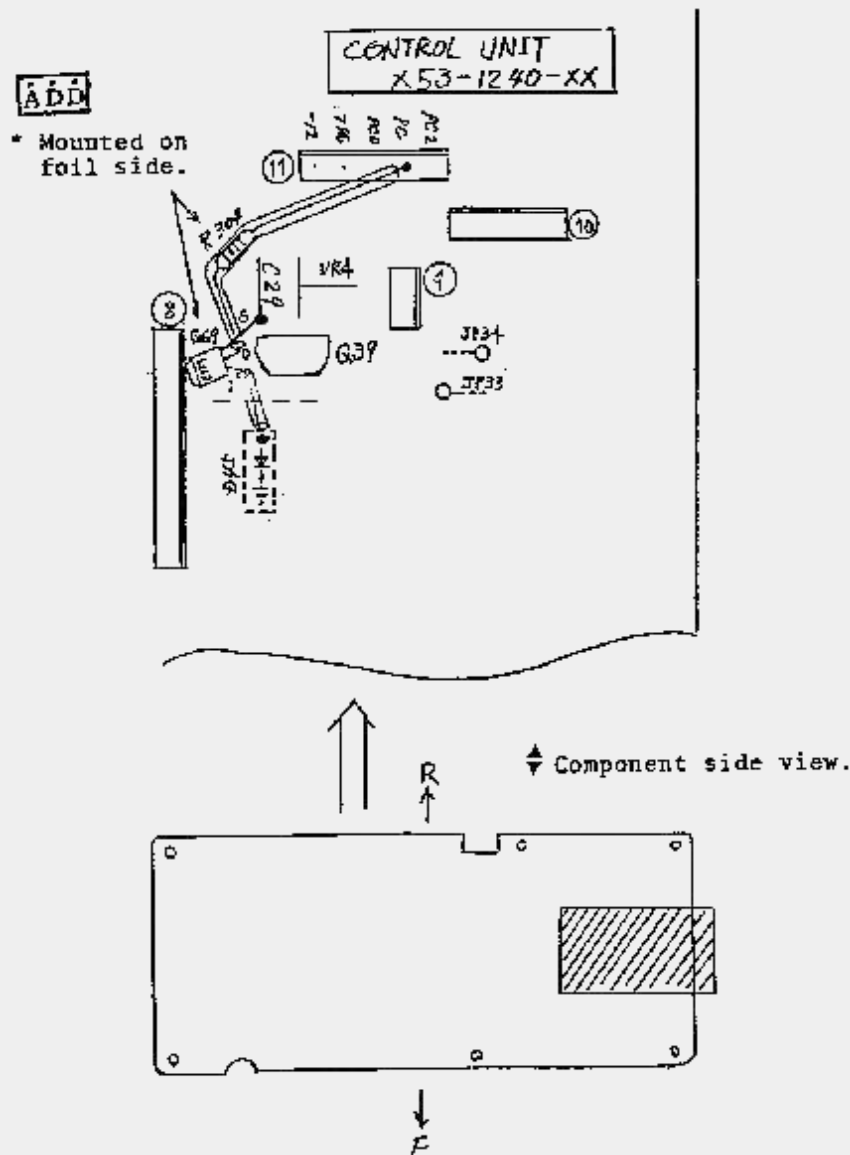
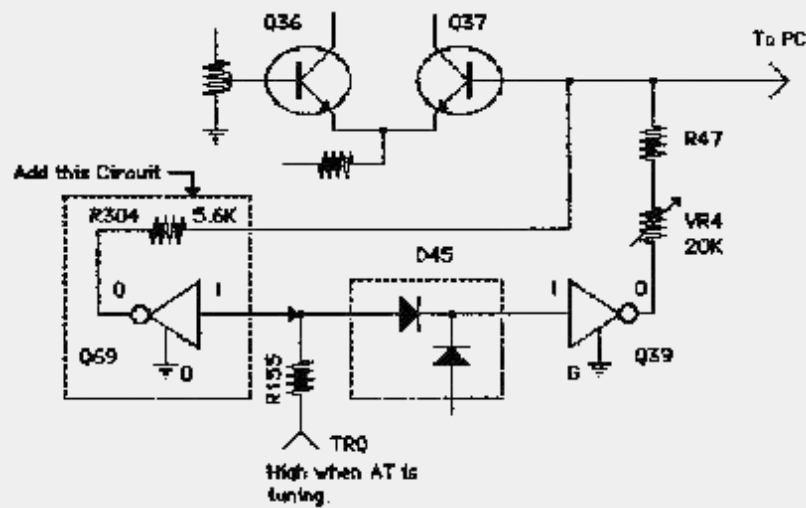

Time required for the modification is 1 hour or less.

15-04-2000**(TS-940) TS-940S PLL unlock****Author:** Trio-Kenwood Communication, inc.

Service Bulletin no. 908 (8-4-1986)

Reports of a PLL unlock on the lower frequencies may be due to low VCO levels. The following change will increase the VCO level and should prevent reoccurrence of this symptom.

Parts required

C168, change to 15 pF 50V (CC45SLIH150J)

Procedure:

1. On the RF unit (X44-1660-00) change C168 from a 33 pF capacitor to a 15 pF 50V capacitor.
2. Readjust the VCO BPF (RF unit L74-76) according to the instructions contained in the TS-940 Service manual.

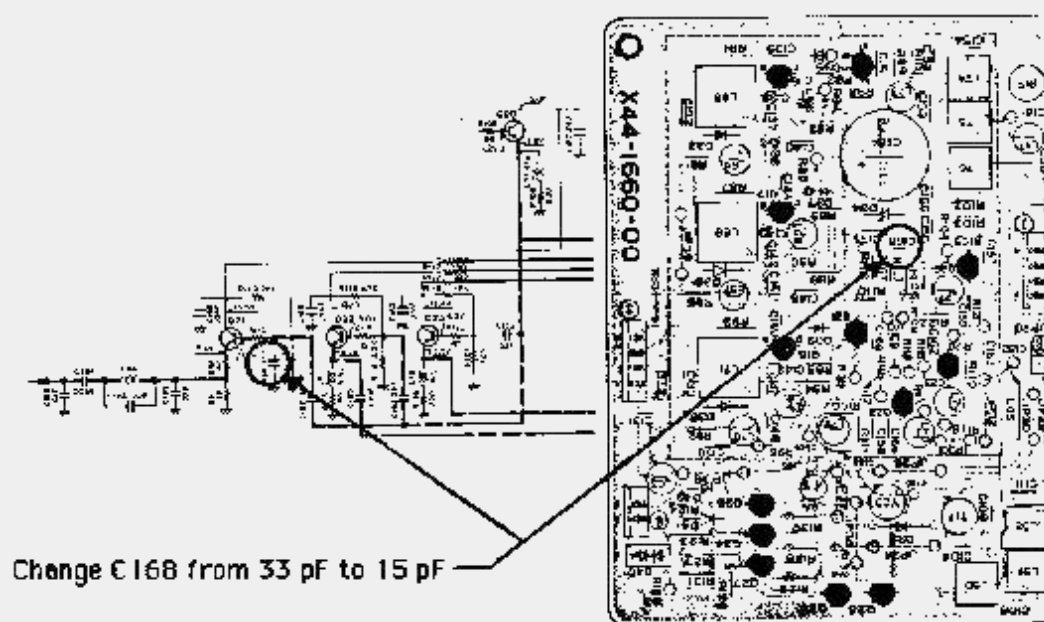

This change is applicable to units prior to serial number 606xxxx.
Time required for this modification is 1 hour or less.

15-04-2000**(TS-940) TS-940S AVR unit capacitor change****Author:** Trio-Kenwood Communication, inc.

Service Bulletin no. 909 (8-4-1986)

In those areas of the country that are subject to large power line voltage fluctuations, excessive voltage may be applied to capacitor C12 on the AVR unit (X43-1500-00). These voltage fluctuations might exceed the capacitor breakdown voltage. Replacing capacitor C12 with a capacitor having a higher breakdown voltage will help prevent this potential problem.

Procedure:

On the AVR unit (X43-1500-00) change C12 from a 6800 μ F capacitor to a 5600 μ F 25 V capacitor (C90-2037-05)

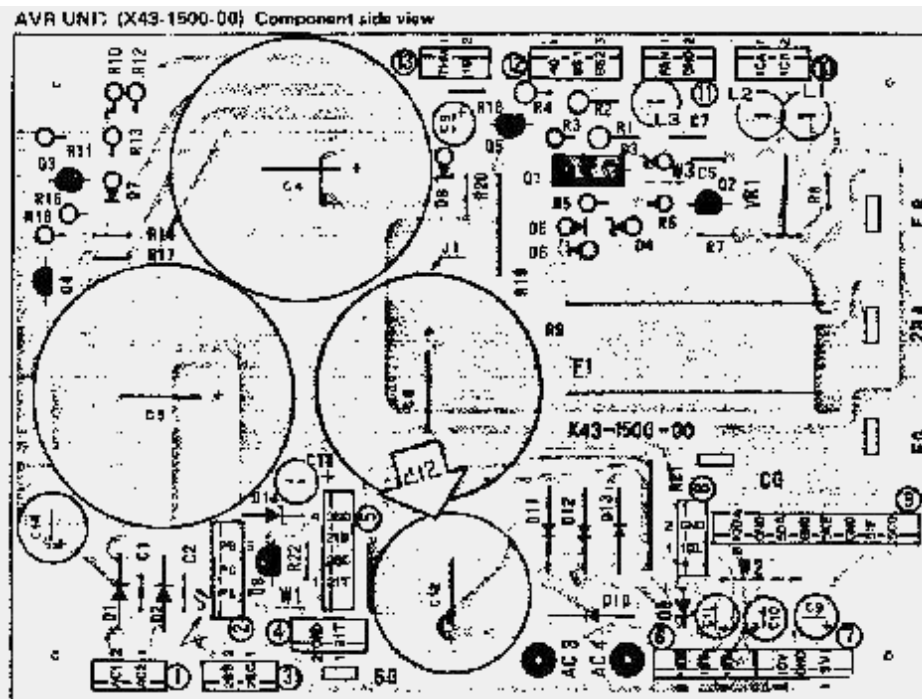

This change is applicable to serial numbers prior to 701xxxx.
Time required for this modification is 1 hour or less.

This modification is read 1272 times.

[top of page](#)

15-04-2000

(TS-940) TS-940S AGC circuit improvements

Author: Trio-Kenwood Communication, inc.

Service Bulletin no. 910 (3-6-1986)

The following changes will improve the adjacent rejection of the TS-940S when a relatively strong nearby signal is present (s-4 or above).

The AGC switch should remain in the SLOW position for all but high speed data communications. Most CW operations will also benefit from operation in the SLOW position.

Parts required:

- 15 Kohm ¼ watt resistor, (RD14CB2E153J)
- 1 µF 16V Electrolytic, (CE04W1C010M)
- 1S1555 diode, (V1S1555)
- .047 µF capacitor, (C91-0119-05)

Procedure:

RF unit

1. Remove jumper wire JP7 and replace it with the parallel combination of the 15 Kohm resistor and the 1S1555 diode. Pay close attention to polarity.
2. Add the 1 µF capacitor as shown in the diagram.

IF unit

Change capacitor C75 from a 1 µF 50V capacitor to a .047 µF 50V capacitor.

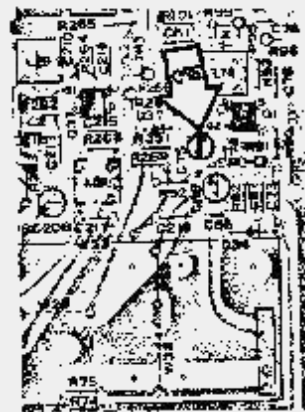
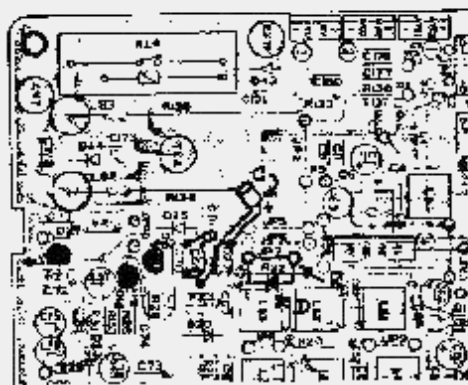
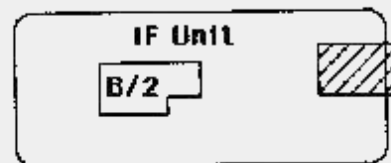
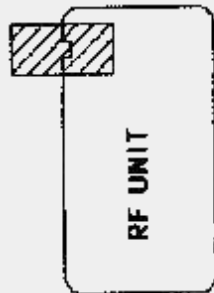
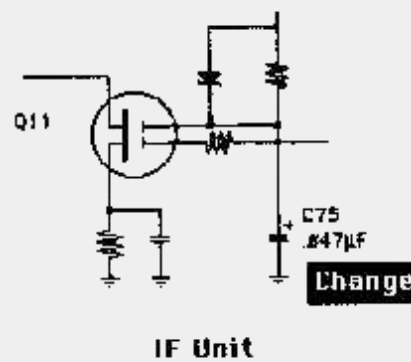
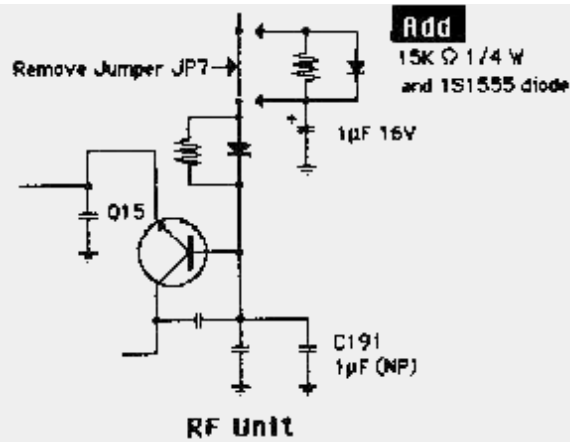

Time required for this modification is 1 hour or less.

This modification is read 1293 times.

[top of page](#)

15-04-2000

(TS-940) TS-940S Signal to noise ratio improvement

Author: Trio-Kenwood Communication, inc.

Service Bulletin no. 913 (28-6-1986)

The following change will reduce the tendency of the Zener diode in the Noise Blanker circuit to cause an increase in the ambient noise level. This change measures that no current flows thru this diode in the normal receive position.

Parts required:

560 ohm 1/2 watt resistor, (RD14CB2E561J)

Procedure:

On the IF unit (X48-1430-00) change R23 from 330 ohms to 560 ohms.

This change will be incorporated in all models beginning with serial number 603xxxx.

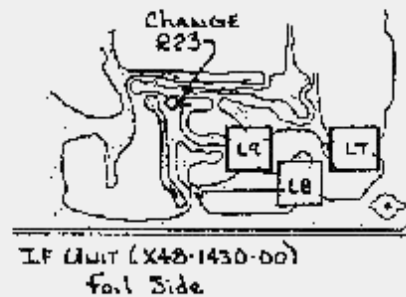
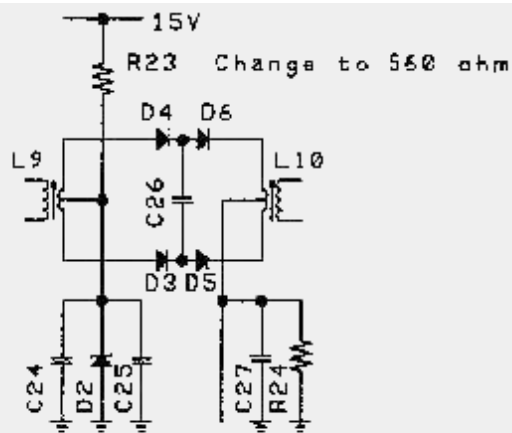

IF UNIT (X48-1430-00)

Time required for this modification is 1 hour or less.

This modification is read 1412 times.

[top of page](#)

15-04-2000

(TS-940) TS-940S VCO carrier to noise ratio improvement

Author: Trio-Kenwood Communication, inc.

Service Bulletin no. 917 (2-3-1987)

The Carrier to Noise ratio of the TS-940S may be improved by the following changes. This bulletin supersedes bulletin number 911 dated September 15, 1986.

Parts required:

PLL UNIT (X50-2020-00)

R120, 129	3.3 Kohm 1/6 watt carbon resistor	RD14CB2C332J
R121, 124	680 ohm 1/6 watt carbon resistor	RD14CB2C681J
C180, 181	.01 μ F disc ceramic capacitor	C91-0117-05
C184, 185	.33 μ F 35V Tantalum capacitor	CS15E1VR33M

RF UNIT (X44-1660-00)

R154, 155	3.9 Kohm 1/6 watt carbon resistor	RD14CB2C392J
C193, 194	1 μ F 25V Tantalum capacitor	CS15E1E010M

Procedure:

On the PLL unit (X50-2020-00) remove capacitor C176, C180, and C181. Change resistor R120 and R129 from 470 ohms to 3.3 Kohm. Change resistor R121 and R124 from 1 Kohm to 680 ohms. Change capacitors C184 and C185 from .22 μ F to .33 μ F 35V tantalum capacitors. Install C180 and C181 in the positions shown in the accompanying diagrams. The use of new capacitors is recommended to improve reliability, don't try to reuse the old capacitors! Capacitors C181 and C180 should be attached to the foil side of the PLL unit.

On the RF unit (X44-1660-00) install the series RC circuit composed of R154 and C193, and R155 and C194, as shown in the accompanying diagrams. As the diagrams illustrate it is easiest to move C132 and C193 to the foil side of the board and install the series RC circuit on the component side.

This is an optional change and may not be performed under warranty. Time required for this modification is 1.5 hour or less.

PLL UNIT

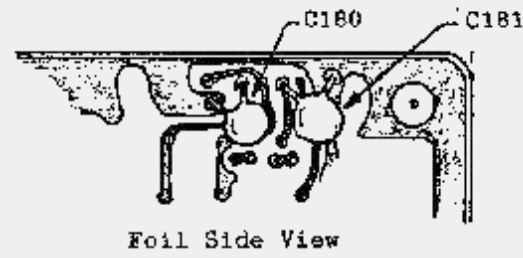
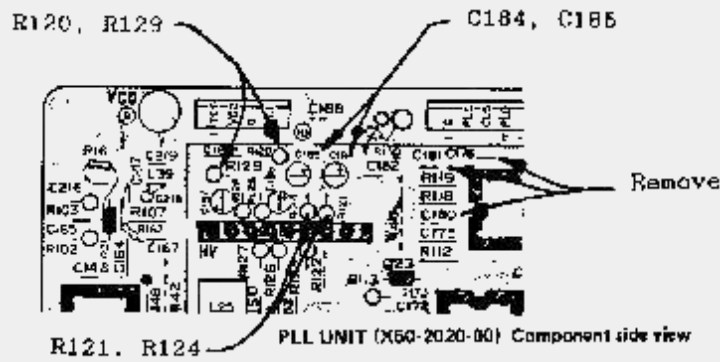

RF UNIT

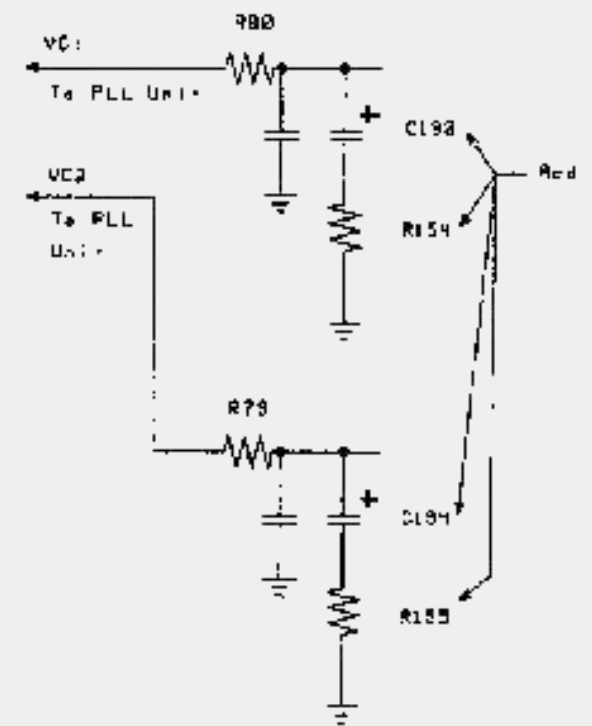
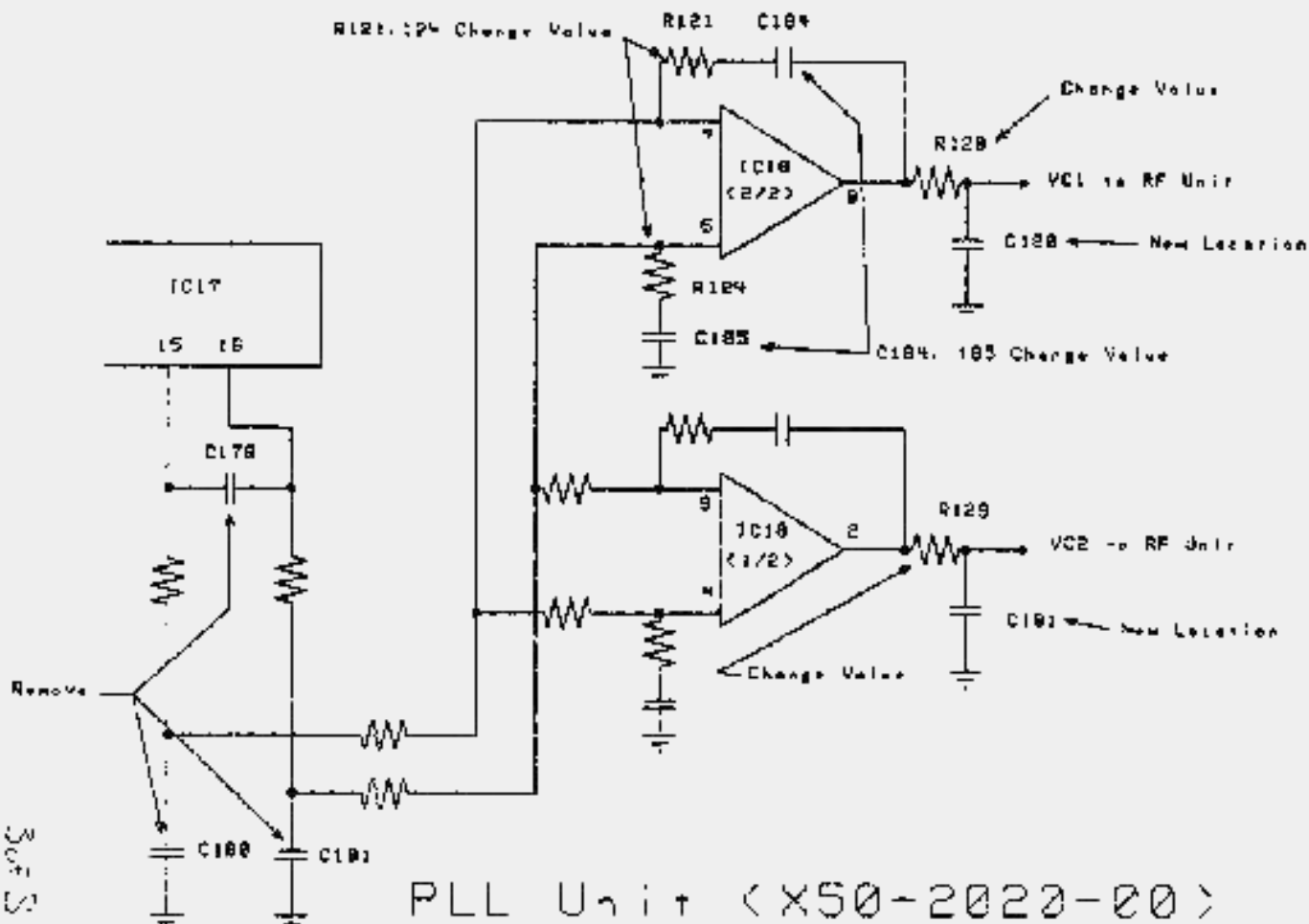
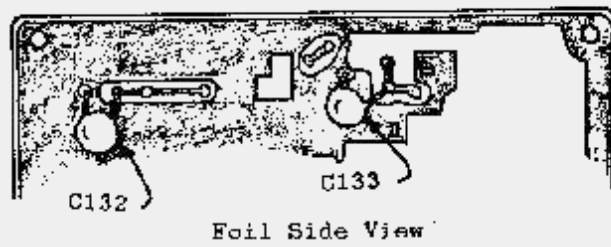
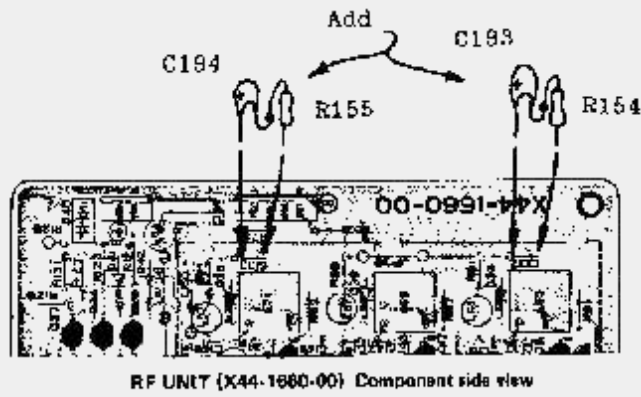

RF Unit (X44-1660-00)

15-04-2000

(TS-940) TS-940S Squelch switching noise

Author: Trio-Kenwood Communication, inc.

Service Bulletin no. 918 (21-7-1987)

In some TS-940S below S/N 711xxxx, a "popping" or "clicking" noise may be heard when the squelch circuit is opened or closed. This may be more noticeable when an optional CW filter is installed. The following procedure will minimize the noise.

Parts required:

R194	560 Kohm 1/6 watt	RD14CB2C564J
R197	220 ohm 1/6 watt	RD14CB2C221J
R355, 356	220 Kohm 1/6 watt	RD14CB2C224J
C284	0.47 μ F, 50V electrolytic	C90-0484-05

Procedure:

1. Disconnect the power cord and antenna from the transceiver.
2. Remove the top and bottom covers (16 screws).
3. Locate the I.F. board on the bottom of the transceiver.
4. Remove the 7 screws from the I.F. board.
5. Carefully unplug connector # 17 (right side of optional CW filter) by prying up on the plug. Do not pull on the wires.
6. Move the 4 wires (yel, org, brn, red) that run across the far side of the I.F. unit out of the way so the board may be removed.
7. Carefully lift and rotate the board toward the left side of the transceiver to expose the foil side of the board.
8. Using a small craft knife, cut the foil at the 3 points shown in figure 1. (top right corner of the board).
9. Unsolder and discard resistors R194 and R197. They are mounted on the component side of the board and soldered on the foil side.
10. Install a 560 Kohm resistor on the component side of the board as shown in figure 2. This resistor is now designated as R194.
11. On the foil side of the board, add the 3 resistors (R197, 355, 368) as shown in figure 3.
12. Add a small jumper wire as shown in figure 3.
13. Add capacitor C282 as shown in figure 3. Observe polarity and insulate the positive (+) lead with shrink tubing.
14. Carefully place the board in its original position (do not pinch wires) and secure it with the 7 screws.
15. Plug in connector # 17. Move the 4 wires on the far side of the board back to their original position.
16. Put the covers back on the TS-940S and secure them with the 16 case screws.
17. Connect the antenna and power cord then test the transceiver for normal operation.

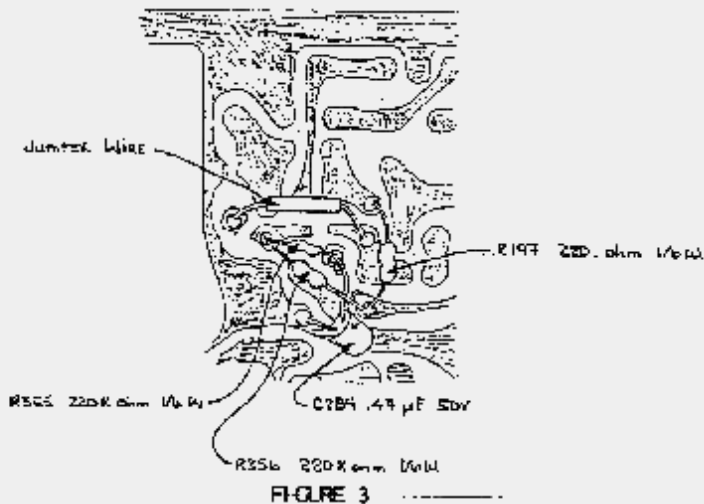
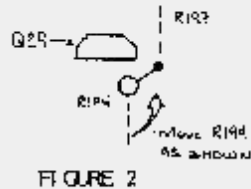
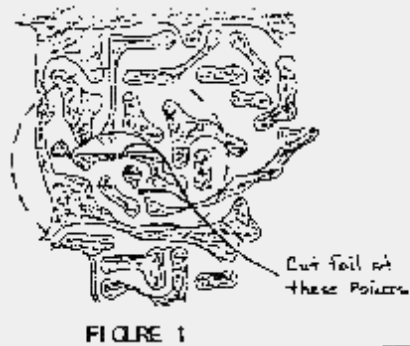

This is an optional change that may not be performed under warranty. Time required for this modification is 1 hour or less.

This modification is read 1184 times.

[top of page](#)

21-04-2000

(TS-940) TS-940S MRF-485 Driver Transistor Notes

Author: Kenwood Communication, inc.

Service Bulletin no. 988 (16-1-1992)

Some MRF-485 transistors are being supplied by Motorola with a Green or Blue color ranking. If these transistors are installed without modifying the driver bias circuit there is a strong possibility that they will fail within a very short time frame.

These high gain transistors cause the circuit to become unstable which can cause the circuit to break into self oscillation, and therefore self-destruct.

Recommendations:

Use of Red, Orange, or Yellow hfe color rankings is recommend. These lower gain transistors work just fine and do not suffer from the circuit instability problem. If you are only able to obtain the high gain transistors you will need to modify the varistor/temperature compensation circuit on the final unit (X45-1400-00) by changing R16 from 1.2 Kohm to 2.2 Kohm.

During its production the TS-940S used two different varistor values. The original part was an STV3H(O). It was changed in mid-production to an SV-03YS. R15 was changed from an 820 ohm resistor to a 1 Kohm resistor at the same time. Therefore the countermeasure differs depending upon the serial number of the radio.

Serial number lot	Varistor	R15	R16	MRF485 Green or Higher rank
106xxxx or earlier	STV3H(O)	820	1.2 K	See "Caution below"
107xxxx or later	SV03YS	1 K	2.2 K	Change R16 from 1.2 to 2.2 K

Caution: If using a Green or higher hfe rank one of the above countermeasure must be taken depending upon the serial number of the set. After replacing the drivers check the bias current. We recommend transmitting for 1 hour in SBB mode with no modulation into a dummy load. After this time frame check the bias current. It must not exceed 300 mA on the original radio. If the current changes you must change R16 from 1.2 Kohm to 2.2 Kohm.

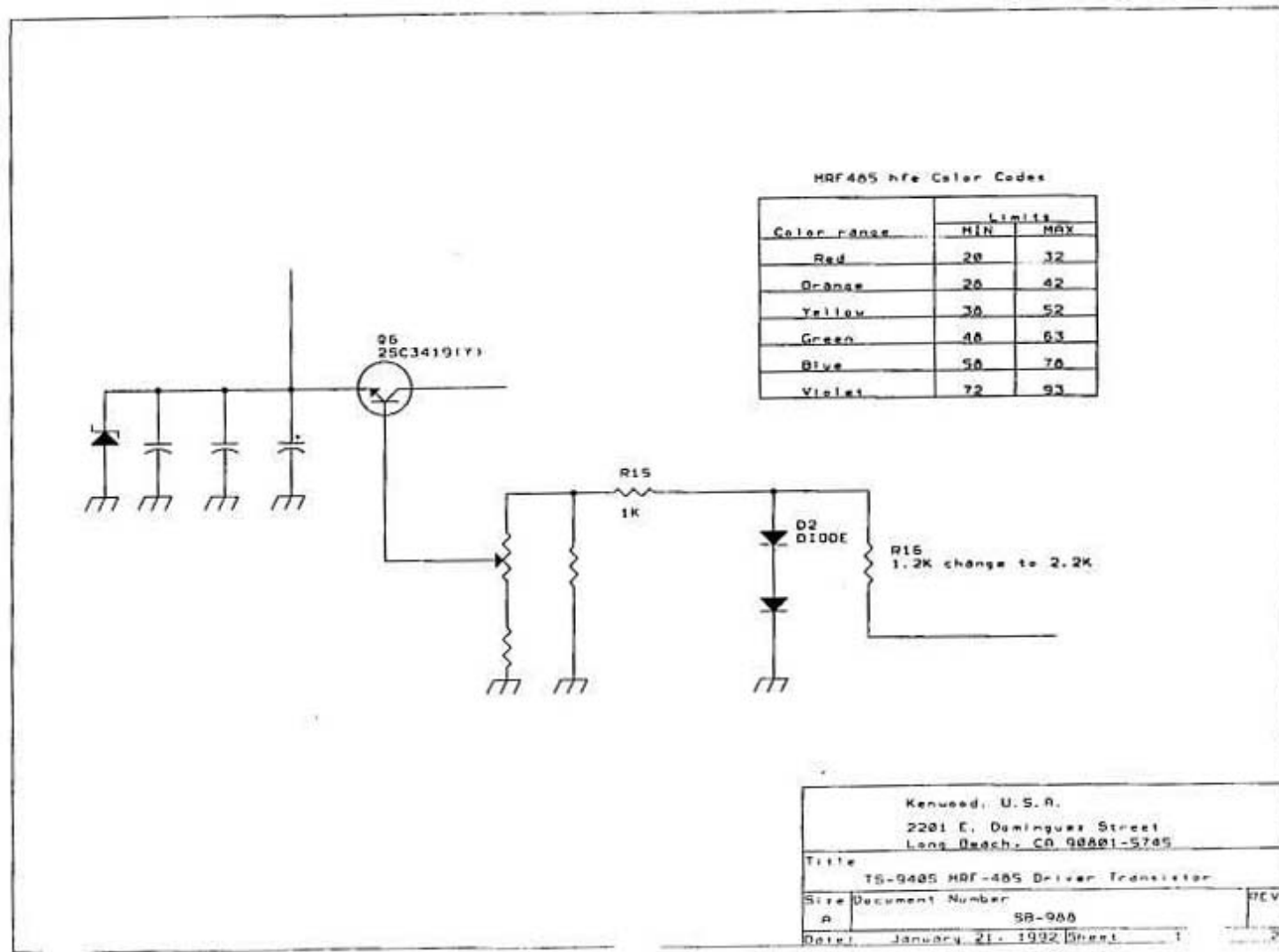

This modification is read 1422 times.

[top of page](#)

24-02-2001

(TS-940) TS-940 PA drivers replacement

Author: Iulian Rosu - va3iul@hotmail.com. MODIFICATION.NET

Any owner of TS-940 knows that this radio has very poor PA drivers, MRF485 from Motorola. In case of damage, to replace these transistors you have to follow some tricky steps. To use low gain transistors, or to use high gain transistors (different dot colors) and modify the bias, etc.

In any situation you have big chances to blow up again the drivers. The first reason is because these transistors are high voltage transistors (29V). We know that high voltage RF transistors have higher gain than 12V transistors, and the possibility of oscillations is also bigger. In the same time the design of the PA layout is not one of the best, which helps to oscillate.

What I did, I replaced MRF485 with 2SC2509 (or any equivalent 10 to 15W, 12V RF transistors in TO220 package). This transistor is cheap (used in most of CB radios). Be careful to connections, 2SC2509 has different pin configuration, BEC, (MRF485 has BCE).

You have to lift the L7 inductor (Final Unit) from the 29V bar, and connect to the output of a 12V/1.5A regulator. This could be a LM7812 (TO3 type). The input of 12V regulator was connected to 29V, from the same point where you disconnected the L7 inductor. I installed LM7812 regulator on a small heat sink, outside of the PA compartment.

Now you have to adjust the bias of the drivers. Put low power in SSB mode and adjust VR2 (Final Unit) to have 0.7V on the base of drivers. Finally if the output power is not 100W you can adjust VR2 (Control Unit), and VR3 (Control Unit) for ALC.

Good luck and I am not responsible for any mistakes you make!
Iulian, VA3IUL

Date: 07-11-2001

User comment

From: [Klaus DJ6MN](#)

Subject: More info

Thanks VA3IUL. This modification is very helpful and works great.

To replace the MRF485, I used 2SC1969 (2 \$, used in CB-Radios). This type is also TO220 package and has the same pin configuration as MRF485. For the voltage regulator I used a 2 Amp Type L78S12 in TO220 package.

I installed the voltage regulator inside the PA compartment at the right upper edge of the heat sink.



Good luck,
Klaus DJ6MN

This modification is read 1489 times.

[top of page](#)

19-07-1998

(TS-950) TS-950SD general coverage transmit mod

1. Remove power and ant.
2. Remove top and bottom covers.
3. Locate the digital unit.
4. Cut diode d-17
5. Reassemble radio.
6. Reset cpu.

This modification is read 1317 times.

[top of page](#)

19-07-1998

(TS-950) Kenwood TS-950 Power On Funktionen

Please notice that all functions only work if you switch off radio first.

Please push the named buttons to start function when switching on the radio:

SUB : SUB receiver capable of scanning, to SUB-scan push and hold the SUB-key and press than the scan key

ENT : Set up ch. 90-99 as amateur band vfos 160-10 m band possible. each memory vfo will accept direct frequency entry. (like ICOM band stack memory)

5+M-VFO : set up ch.80-89 to accept any memory data

RX/A : Turn ON/OFF SUB receiver marker on SM 230 Monitor in 100 kHz/250kHz and 25kHz sweep mode.

IC+COMP : stop transmit if I_c exceeds 1,7 A. Power output limited to 10 Watt

8.83 + RIT : Both 8.83 MHz and 455 kHz IF Filters are selectable on transmit. Each memory channel is also capable of storing this setting.

Memory protect: Cutting D 129 on control unit protects memory contents from being erased.

Write protect : Cutting D 18 on Control Unit write protects all memory channels.

from Hanno DG8JZ

This modification is read 1148 times.

[top of page](#)

30-05-1999

(TS-950) Kenwood TS-950-SDX Allows sub-rcvr to be on different band than Main receiver

Allows sub-rcvr to be on different band than Main receiver.

This is a Power On function mod.

Start with radio turned off.

Hold down buttons SUB, M/S, RX/SUB while turning on the power ON. Now you can listen to 15M on sub-rcvr with Main rcvr on 20M. or any other band or visa-versa. Both receivers will be in the same mode USB, LSB, CW etc.

73,

George, K5GH

This modification is read 1036 times.

[top of page](#)

20-04-2000

(TS-950) TS-950SD Speech processor noise

Author: Trio-Kenwood Communication, inc.

Service Bulletin no. 959 (12-1-1990)

When the Processor-In control is set to some level below 10 dB of compression, a crackling noise can be induced on the transmit signal. The following modification will reduce the noise. After the modification has been performed, the noise can only be heard when the Processor-In control is set too low to be functional.

Note: This modification has already been performed on models starting with serial number 0120441.

Required parts:

Transistor (PNP)	(2SC2458Y)
4.7 ohm, 1/6 watt resistor	(RD14CB2C4R7J)
10 ohm chip resistor	(RK73FB2A100J)
39 ohm chip resistor	(RK73FB2A390J)
10 Kohm chip resistor	(RK73FB2A103J)

1. Disconnect the power cord and antenna.
2. Remove the top and bottom covers (18 screws).
3. Locate the Signal board on the bottom of the transceiver. This is the front right board of the 4 boards on the bottom of the transceiver.
4. Disconnect the 3 flex cables and remove the 6 mounting screws from the Signal board.
5. Carefully lift the board and rotate it toward the AF unit (front left board) to expose the foil side of the Signal board. Loosen the wire harness as necessary to rotate the board.

The following will be performed on the foil side of the Signal board.

1. Cut the foil between pin 3 of CN18 and chip resistor R229.
2. Desolder and remove R229.
3. Solder a 10 ohm chip resistor across the cut foil.
4. Solder a 39 ohm chip resistor in place of R229 (it will be slightly offset due to the installation of the 10 ohm resistor).
5. Solder a 4.7 ohm resistor to the collector of a 2SC2458(Y) transistor. Shorten the lead length to accommodate the following installation and insulate the leads with shrink tubing.
6. Solder the exposed end of the 4.7 ohm resistor to chip capacitor C167.
7. Solder the base and emitter leads as shown in the accompanying diagram.
8. Solder a 10 Kohm resistor to the circuit as shown.

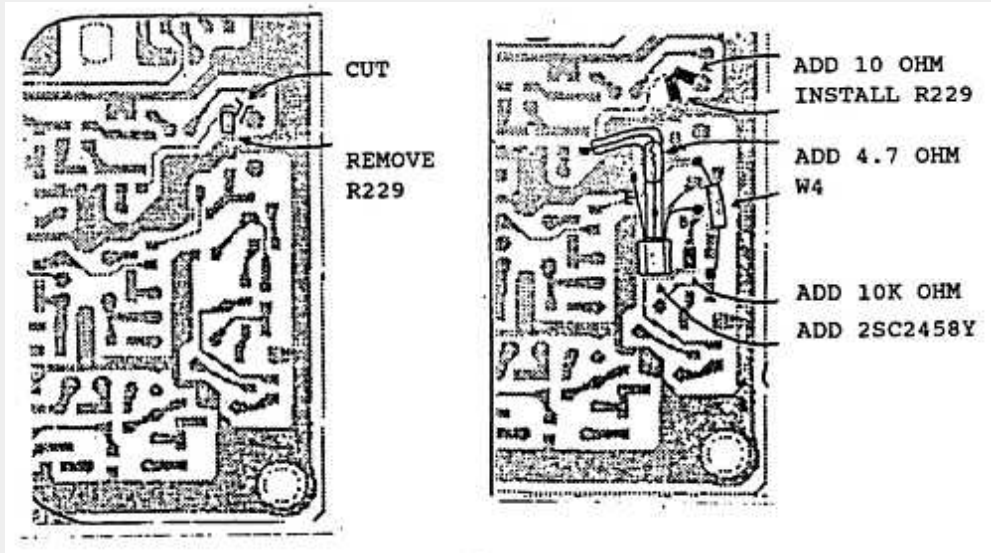
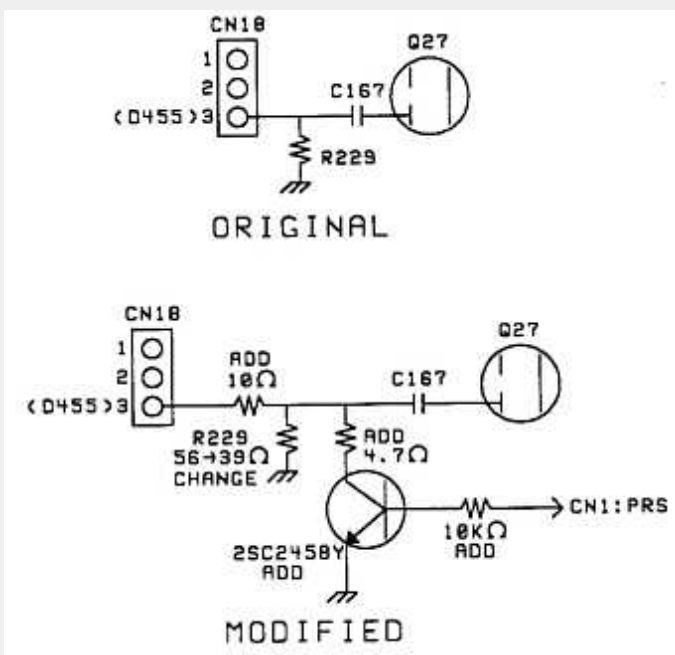

This modification is covered under the 1 year warranty.
Time required to perform the modification is 1 hour or less.

This modification is read 880 times.

[top of page](#)

20-04-2000

(TS-950) TS-950SD N.B. Gate switching noise

Author: Trio-Kenwood Communication, inc.

Service Bulletin no. 961 (11-1-1990)

Switching noise from the main band noise blanker circuit may be induced on the 15V line and pass through the AF amplifier to the speaker. The following modification will correct this condition.

Note: This modification has already been performed on models starting with serial number 104xxxx.

Required parts:

120 ohm, 1/8 watt resistor (RD14BB2B121J)
100 μ F, 16 V electrolytic capacitor (CE04EW1C101M)

1. Disconnect the power cord and antenna.
2. Remove the top and bottom covers (18 screws).
3. Locate the AF board. This is the front left board of the 4 boards on the bottom of the transceiver.

This work will be done on the component side of the AF board.

1. Cut the foil shown in the accompanying diagrams.
2. Add a 120 ohm resistor between the emitter of Q48 and the 15 V line.
3. Add a 100 μ F, 16 V capacitor between the 15 V line and ground.
4. Reassemble the transceiver.

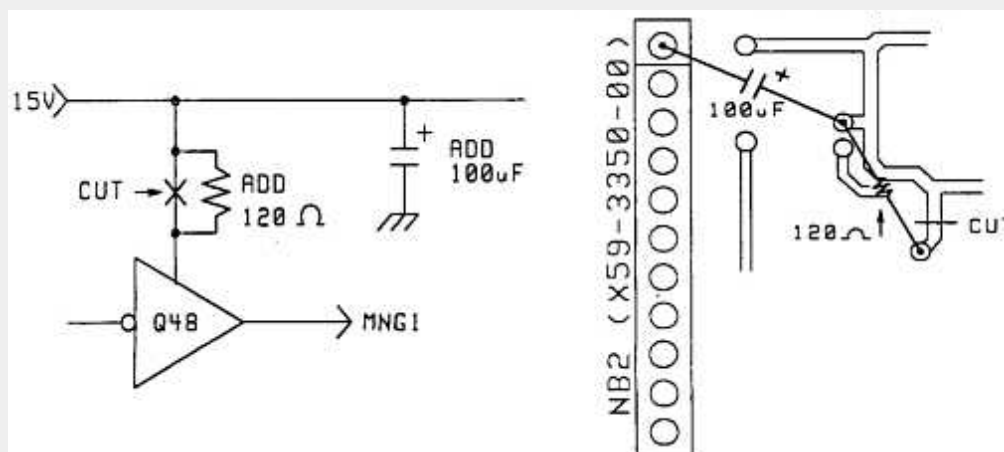

This modification is covered under the 1 year warranty.
Time required to perform the modification is ½ hour.

This modification is read 829 times.

[top of page](#)

20-04-2000

(TS-950) TS-950SD Early protection with TL-922A

Author: Trio-Kenwood Communication, inc.

Service Bulletin no. 962 (17-1-1990)

The TS-950SD RX to TX switching time in semi break-in is approximately 10 mS. At the key down, the transceiver momentarily sees an open circuit because the linear's keying relay has not engaged. As a result, the transceiver's protection circuit turns on, causing the output power to be reduced. The following modification will make the RX to RX switching time, in semi-break-in, approximately 30 mS. This modification does not affect full break-in switching. Increasing the switching time to 30 mS may restrict certain long distance high speed communications.

Required parts:

Digital transistor (QTY 2)	(DTC124ES)
100 Kohm, ¼ resistor	(RD14BB2E104J)
2.2 µF, 50 V electrolytic capacitor	(CE04EW1H2R2M)

1. Disconnect the power cord and antenna.
2. Remove the top and bottom covers (18 screws).
3. Remove the top screw from each side of the front panel assembly.
4. Loosen the bottom screw on each side of the front panel assembly.
5. Pull the front panel assembly forward to expose the Digital and Control boards.
6. Remove the two screws that secure Control board B/3 to the top of the chassis and swing the board out of the way.
7. Remove the 4 screws from Control board A/3 and rotate the board down. Disconnect the right hand plugs as necessary to expose the foil side of the Control board.
8. Install the circuit shown in figure 1 on the foil side of Control board A/3.
9. Assemble the transceiver by reversing steps 1 - 7.

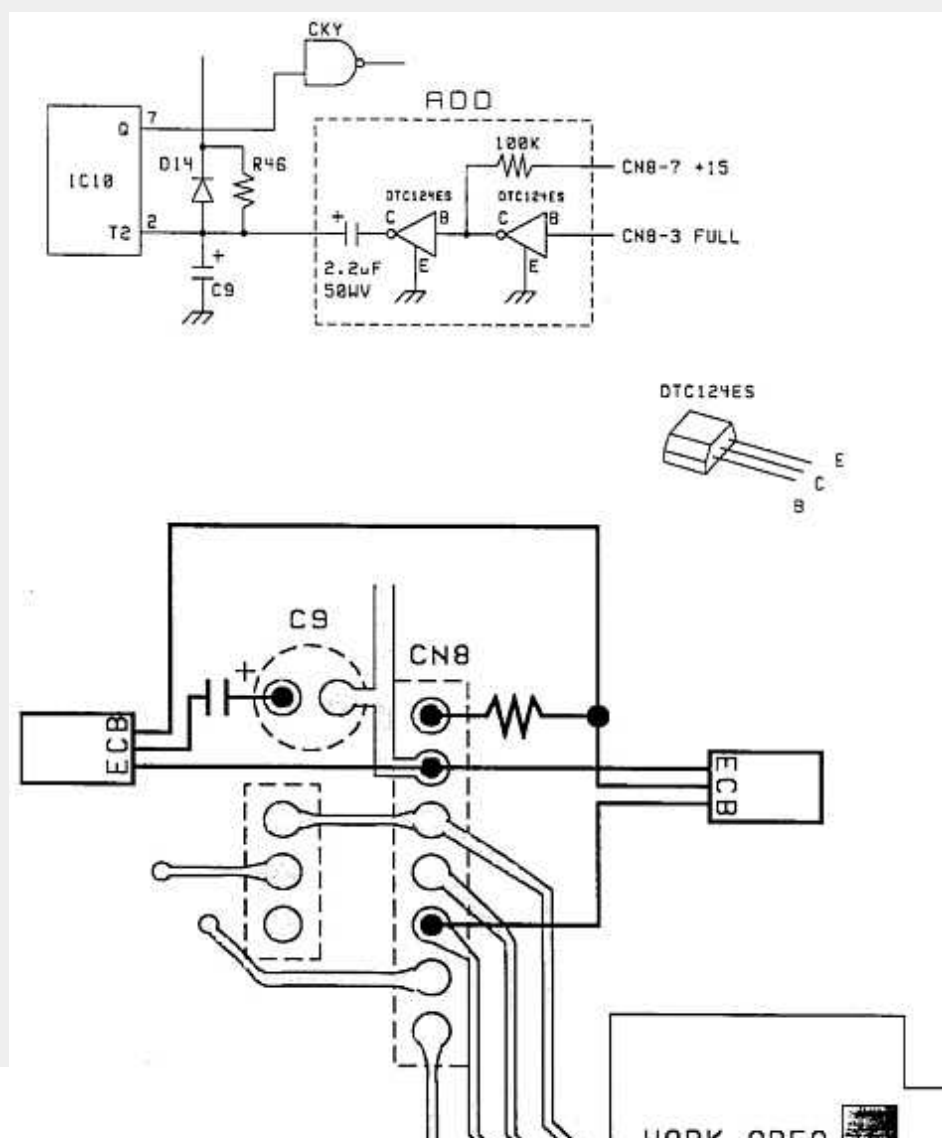

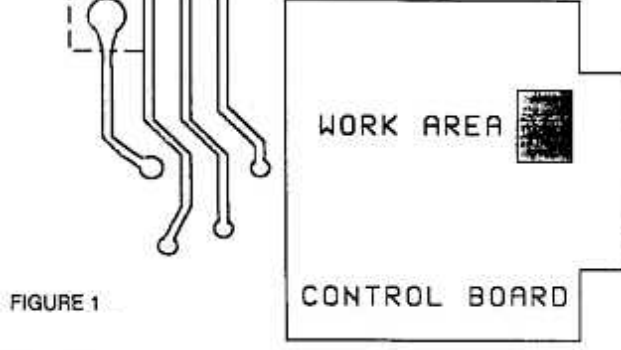

FIGURE 1

This modification is covered under the 1 year warranty.
Time required to perform the modification is 1 hour or less.

This modification is read 878 times.

[top of page](#)

20-04-2000

(TS-950) TS-950SD RX digital noise

Author: Trio-Kenwood Communication, inc.

Service Bulletin no. 963 (17-1-1990)

Some early TS-950SD transceivers may exhibit a low Signal to Noise ratio on ten and fifteen meters. In addition, rotating the encoder may allow the user to hear a crackling noise in his headphones. The following modification will correct this condition.

Note: This modification has already been performed on model from serial number 101xxxx.

1. Disconnect the power cord and antenna.
2. Remove the top and bottom covers (18 screws).
3. Open the subchassis as shown in figure 1 (remove 4 top screws, remove 3 back panel screws, unplug the RX ANT OUT and DRIVE IN connectors).
4. Remove the cover from the subchassis (12 screws). Figure 1.
5. Remove the 9 screws from the Filter board.
6. Desolder the antenna connector wires at the antenna connector. Do not damage the surge absorber.
7. Rotate the Filter unit to expose the foil side of the board. Disconnect coax cables as necessary to rotate the board and remove the mesh plate as the board is rotated.
8. Cut the two foils as shown in figure 2.
9. Assemble the transceiver by reversing steps 1 - 7. Remember to install the mesh plate, resolder the antenna connector, and plug in the two connectors on the back panel.

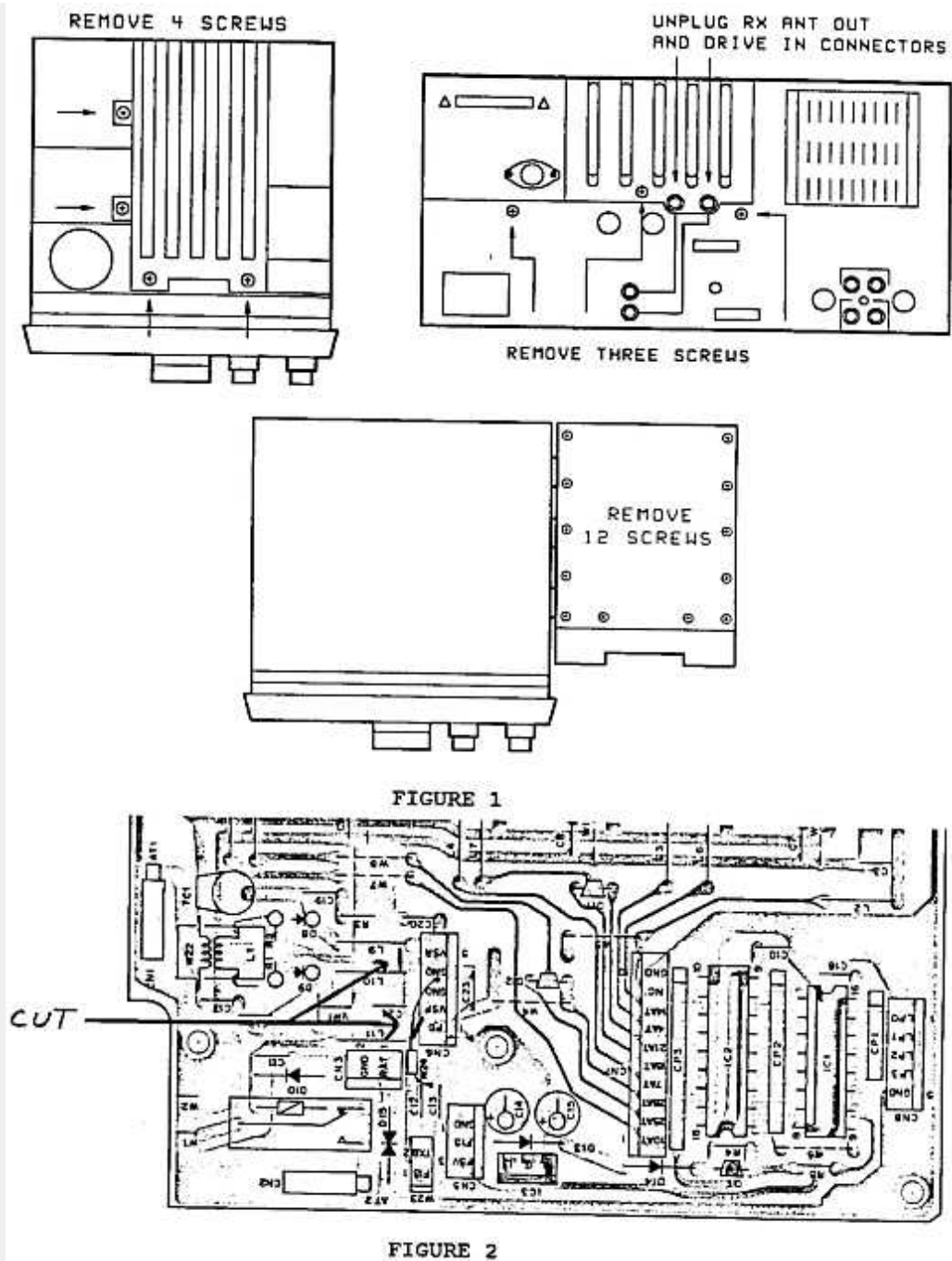

This modification is covered under the 1 year warranty.
 Time required to perform the modification is 1 hour or less.

This modification is read 888 times.

[top of page](#)

20-04-2000

(TS-950) TS-950SD Two second TX power delay with MONI on

Author: Trio-Kenwood Communication, inc.

Service Bulletin no. 964 (22-1-1990)

When the MONI switch is turned on, transmit power may not develop for two seconds after key down. During this time, the ALC meter will pin and the SWR meter will read high. This will more likely develop on 18 MHz and 21 MHz bands. The following modification will correct this condition.

Note: This modification has already been performed on model from serial number 0120441.

Required parts:

2.2 Kohm chip resistor (RK73FB2A222J)

1. Disconnect the power cord and antenna.
2. Remove the top and bottom covers (18 screws).
3. Locate the RF unit on the bottom of the transceiver. This is the back left board of the four boards on the bottom of the transceiver.
4. Remove the RF board shield plate (4 screws).
5. Remove the 3 remaining screws from the RF board.

6. Remove the black screw that secures the DRIVE OUT/RX ANT IN jack to the back panel.
7. Disconnect the right hand coax cables from the RF board and unplug connector #2.
8. Slide the RF board forward and then rotate it towards the front of the transceiver to expose the foil side of the board.
9. Locate chip resistor R135 as shown in figure 1.
10. Replace R135 with a 2.2 Kohm chip resistor.
11. Assemble the transceiver by reversing steps 1 - 8.

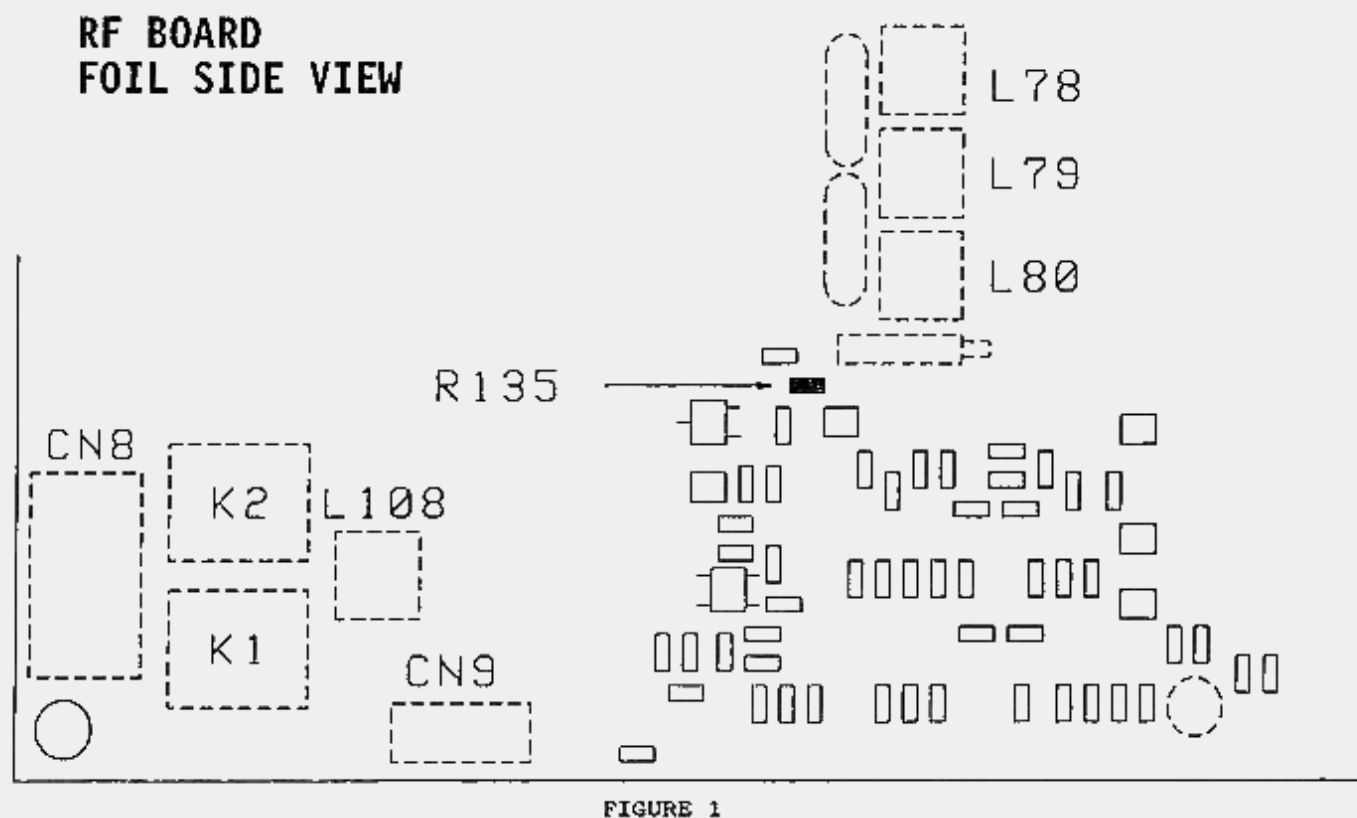

This modification is covered under the 1 year warranty.
Time required to perform the modification is 1 hour or less.

This modification is read 844 times.

[top of page](#)

20-04-2000

(TS-950) TS-950/SD Receiver noise

Author: Trio-Kenwood Communication, inc.

Service Bulletin no. 971 (29-5-1990)

About 1 mV noise is present at the speaker or headphone jack in the receive mode with the AF GAIN control set to minimum. If the transceiver is in the CW mode, a faint tone might also be heard through the headphones (sidetone leakage). The following modification will reduce the level of the noise and the tone.

Required parts:
2SD1257K(S)

1. Disconnect the power cord and antenna.
2. Remove the top and bottom covers (18 screws).
3. Locate the RF unit on the bottom of the transceiver. This is the back left board of the four boards on the bottom of the transceiver.
4. Remove the screws from the AF unit and disconnect the plugs as necessary to turn the board over to expose the foil side of the board.
5. Replace Q6 with a 2SD1757K(S).
6. Solder a 22 AWG jumper wire as shown in figure 1.

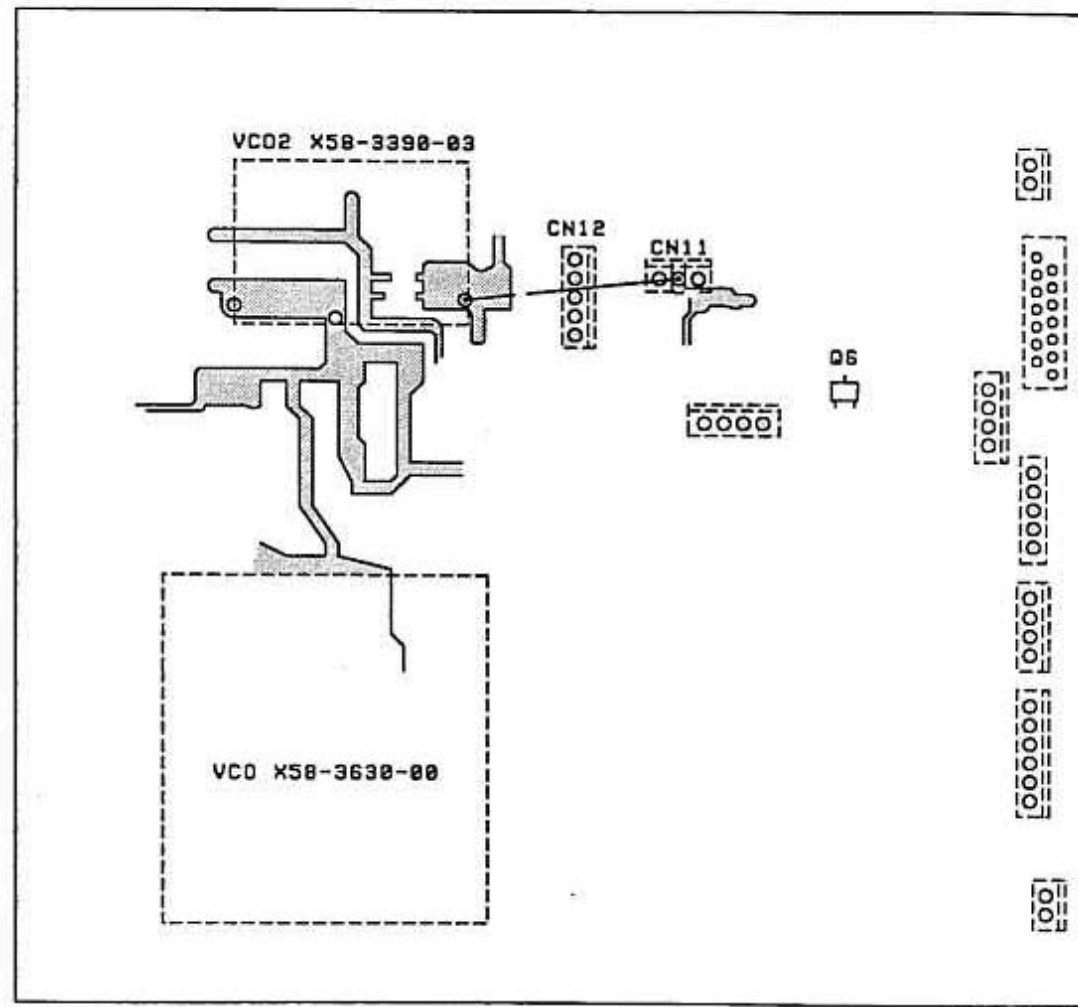

This modification may be covered under warranty.
Time required to perform the modification is 1 hour or less.

This modification is read 869 times.

[top of page](#)

21-04-2000

(TS-950) TS-950S/SD TX image on 18.115 MHz

Author: Kenwood Communication, inc.

Service Bulletin no. 982 (6-2-1991)

Some TS-950SD owners have reported a transmit image at 18.115 MHz that cause the receiving station to hear distortion on the carrier. If the operating frequency is shift 3 KHz above or below 18.115 MHz, the image disappears. This modification will lower the image level from -30 dB (worse case) to better then - 40 dB by installing a trap on the 455 KHz I.F.

Required parts:

4 pF Trimmer capacitor	C05-0308-05
40 pF Trimmer capacitor	C05-0309-05
2.2 μ H coil	L40-2292-14

Modification:

1. Disconnect the power cord and antenna.
2. Remove the top and bottom covers (18 screws).
3. Locate the I.F. board on the bottom of the transceiver. This is the back right board of the 4 boards on the bottom of the transceiver. Figure 1.
4. Locate L36 by connector CN17 on the I.F. board. Figure 2.
5. Install and solder into place a 4 pF trimmer capacitor across L36. Figure 3.
6. Install a 2.2 μ H coil and 40 pF trimmer capacitor in series from the output of L36 to ground. The can of L31 can be used for ground. Figure 3.

Alignment:

1. Connect the TS-950S/SD to a power meter and 50 ohm load.
2. If you are working on the TS-950S digital, connect the DSP cables on the bottom cover to the back panel.
3. In the CW mode, adjust the front panel power control for 150 Watt while the ALC level is just at the starting point on the meter. This will create the highest image level condition.
4. Using a monitor receiver with narrow filters installed and AGC set to off, tune the receiver to the image frequency.
5. Alternately adjust the two trimmer capacitors until the image cannot be heard. This procedure may need to be repeated several times.
6. Push the wire harness around the I.F. board toward the chassis of the transceiver.
7. Assemble the transceiver.

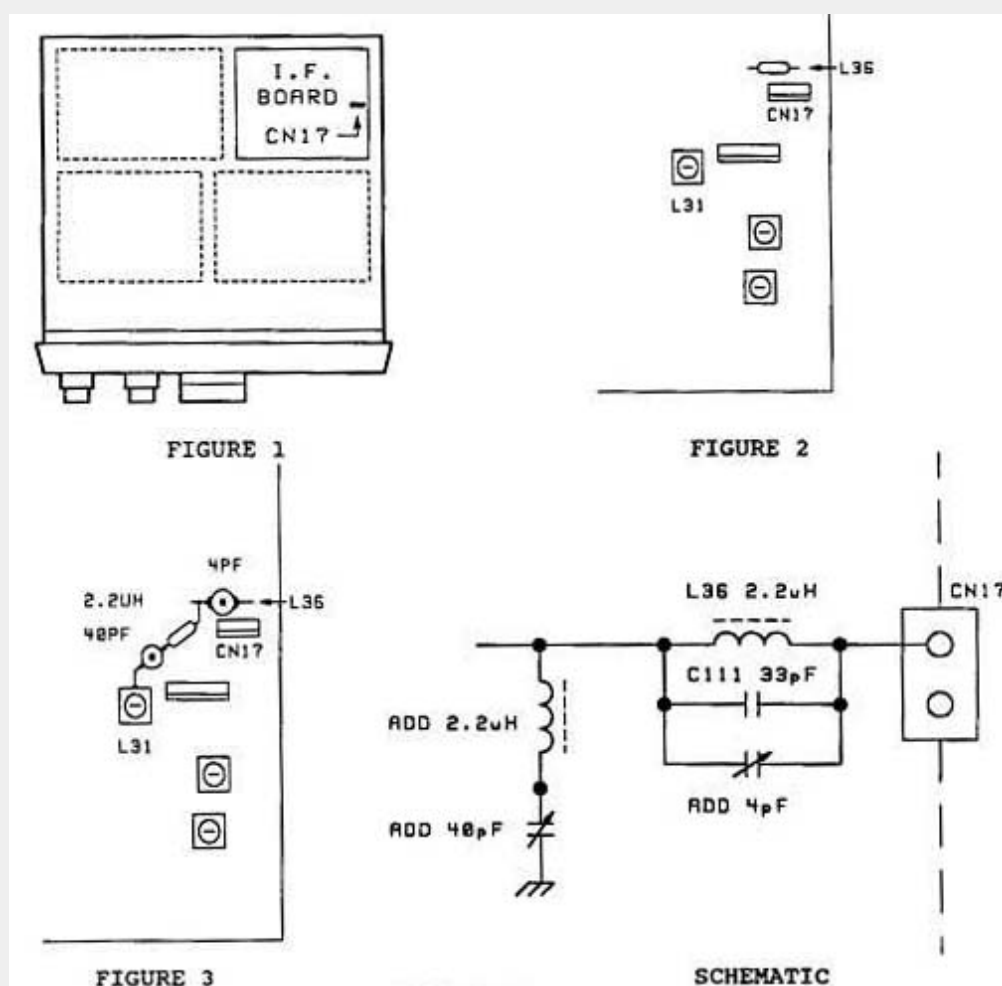

This modification may be covered under 1 year warranty.
 Time required to perform this modification is 1 hour or less.

This modification is read 827 times.

[top of page](#)

21-04-2000

(TS-950) TS-950S/SD 80 meter spurious emission

Author: Kenwood Communication, inc.

Service Bulletin no. 984 (6-2-1991)

Some TS-950S/SD owners have reported a transmit spurious emission between 3.500 MHz and 3.520 MHz. The modification will reduce the spurious emission to - 65 dB.

Required parts:

10 pF capacitor	CC73FCH1H100J	QTY. 1
16 pF capacitor	CC73FCH1H160J	QTY. 1
12 uH coil	L40-1201-17	QTY. 1
2.6 X 4 mm screws	N09-0650-05	QTY. 4

1. Disconnect the power cord and antenna.
2. Remove the top and bottom covers (18 screws).
3. Open the subchassis to expose the PLL board (figures 1-3). To open the subchassis remove 4 top screws, remove 3 back screws, and unplug the RX ANT OUT and DRIVE In connectors.

4. Replace the four VCO shield plate screws with the type listed above. Figure 3.
5. Close the subchassis and secure it with the screws removed in step 3.
6. Locate the A.F. board on the bottom of the transceiver. Figure 4.
7. Remove the board's mounting screws and disconnect the necessary connectors to expose the bottom of the board.
8. Locate the foil pattern area shown in Figure 5. This area is below IC11.
9. Cut the foil pattern and add the components shown in Figure 6.
10. Assemble the transceiver. Remember to plug in the two connectors on the back panel.

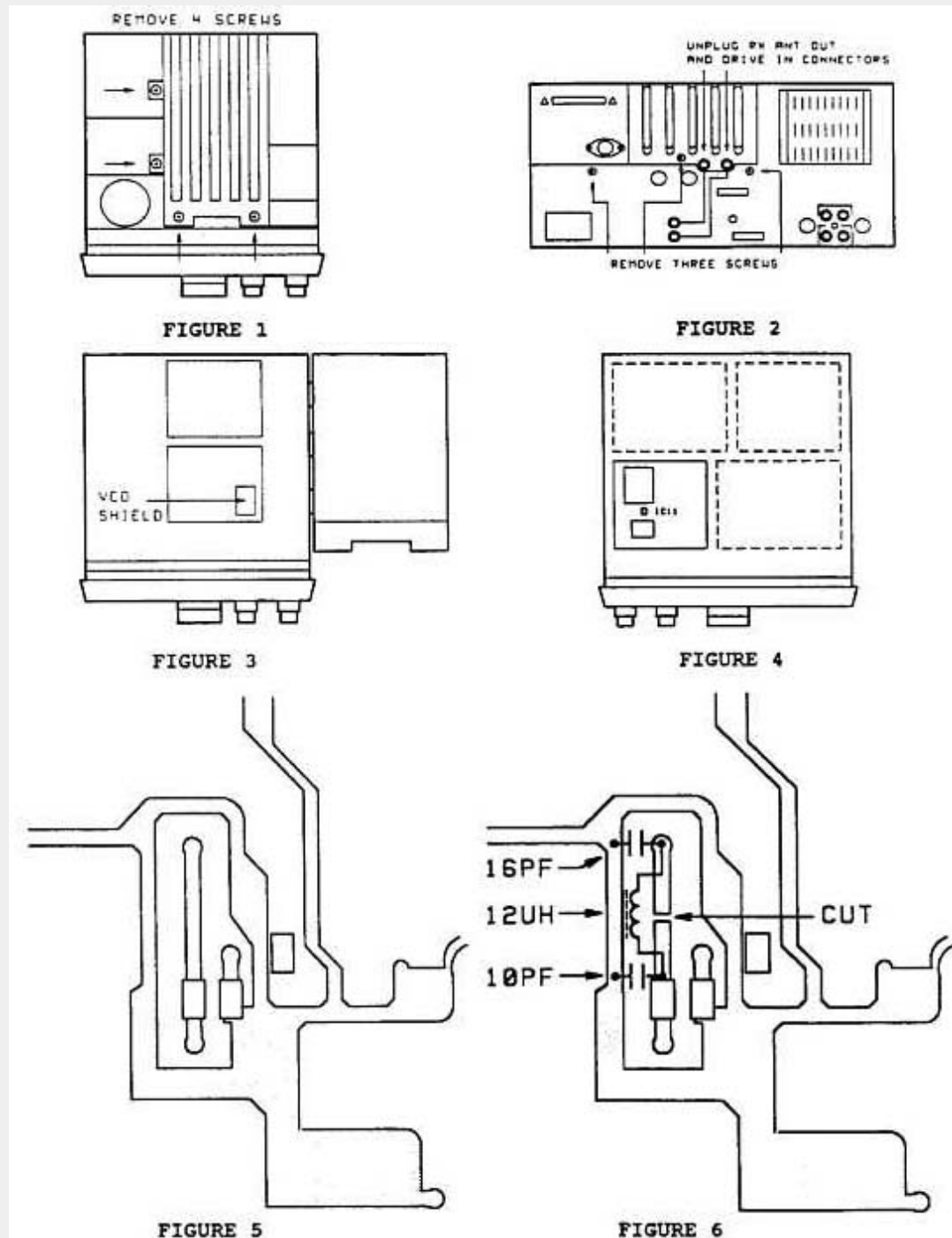

This modification is covered under the 1 year warranty.
 Time required to perform this modification is 1 hour or less.

This modification is read 812 times.

[top of page](#)

21-04-2000
(TS-950) TS-950S Final bias circuit change

It is possible to exceed the maximum Vcbo rating of the MRF429 transistors used in the TS-950S/SD if the unit is operated at excessive transmit power levels (greater than the normal factory output power setting). This results in a collector to base short on the MRF429. This causes excessive current to be drawn thru R17 and or R18 of the final bias circuit. This can cause a large amount of smoke from the overloaded resistors. It does not normally cause damage to surrounding components. (You might wish to check Q7, VR2, Q8 and the fuse just as a precaution!)

R17 and R18 are carbon type resistors (27 ohms ½ w). Carbon resistors can emit quite a bit of smoke when overload in this manner and can be the cause of considerable concern by the operator!

In order to ease operator concern we recommend replacing R17, and R18 on the final unit (X45-3330-00) with ceramic resistors whenever replacing the final transistors. These special resistors have been designed to open quickly if the current rating is exceeded. This prevents smoking and the odors associated with burning resistors.

Parts required:

27 ohm ½ watt ceramic resistor, (R92-1286-05)

Precautions:

1. The MRF-429 transistors generally fail one of two ways:
 - A. The collector/base junction opens. R17 and R18 are not damaged when this occurs.
 - B. If the MRF-429's are operated at RF power levels higher than the absolute maximum Vcbo rating the collector/base junction fails. This causes excessive current to flow thru the base circuit.
2. If the MRF-429's short collector to base with ceramic resistors there will be very little smoke before the resistor opens. The outward appearance of the resistors will not change, so you must make sure to check the resistors with an ohmmeter before installing new finals.
3. If R17 or R18 should open there will not be an appreciable change in the base circuit current. It is essential, however, that these resistors be in good working order as they ensure stable operation of the final amplifiers.
4. R17 and R18 must be replaced whenever you replace the final transistors. The ceramic resistors are easy to identify. They are rectangular and white in color.

Replacement Procedure:

1. Replace the bad MRF-429 transistors.
2. Remove R17 and R18 from the component side of the Final circuit board.
3. Solder the ceramic resistor directly to the base and emitter of the final transistors. The stability of the circuit is improved by soldering R17 and R18 directly to the base and emitter of the finals. Do not install them in the old locations!

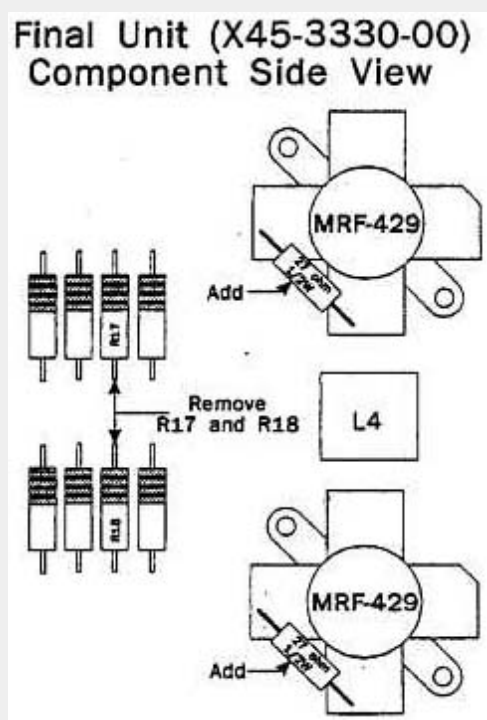

21-04-2000

(TS-950) TS-950S Rear panel cooling fan

Author: Kenwood Communication, inc.

Service Bulletin no. 991 (24-1-1992)

The 50 watt power down circuit will begin to operate if the cooling fan on the rear panel fails to operate after 15 minutes of continuous transmission in order to protect the final amplifier circuit. Failure of the fan will prevent the power down circuit from returning transmit power to normal levels since the transformer temperature remains high. This trouble can sometimes be traced to a pinched/burnt wire near resistor R17 of the AVR unit (X43-3070-01).

Causes:

If the red wire attached to the connector CN2 of the AVR unit is pinched between the chassis and ground the insulation might be damaged and allow this line to be short to the chassis. This wire supplies 15 Vdc to the fan motor thru resistor R17. Excessive current is drawn thru R17 under this circumstance, approximately 1.5 A rather than the normal .5 A. This can cause the resistor to become red hot and damage the surrounding circuit board, since R17 is a metal oxide film resistor.

Corrective action:

R17 should be replaced with a ceramic resistor if this symptom is encountered. Replacing the metal oxide film resistor with a ceramic resistor will prevent damage to the circuit board should the red lead become shorted.

Parts required:

10 ohm 2 watt ceramic resistor, R92-1285-05

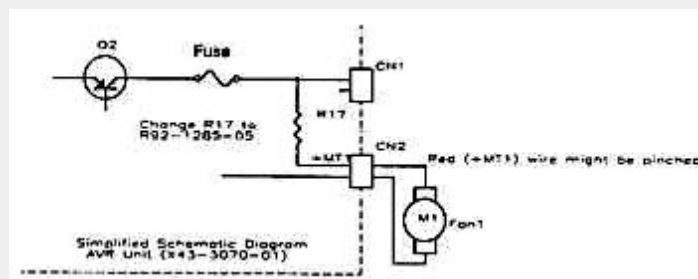

This modification is read 885 times.

[top of page](#)

22-04-2000

(TS-950) TS-950SDX Mode switching

Author: Kenwood Communication, inc.

Service Bulletin no. 998 (3 August 1992)

Occasionally the TS-950SDX will transmit instantaneously when the mode is switched from SSB to CW with the VOX turned on. The frequency of occurrence depends upon the setting of the VOX GAIN and DELAY controls.

Cause:

A small amount of RF feedback is felt on analog switches IC5 and IC6 in the AF unit. This RF causes the timing circuit to actuate briefly when the mode is changed with VOX ON.

Warning: This radio uses micro-sized surface mount component, and/or multi-layer circuit boards. *If you are not familiar with the techniques for service of this type of equipment do not attempt this modification yourself.* You will invalidate your warranty if you attempt to modify the equipment and damage the radio. If you are at all in doubt about your qualification to perform this modification you should seek qualified assistance.

Required parts:

C191: 4.7 μ F, 25 V electrolytic capacitor (CW04EW1W4R7M)

Procedure:

1. Unplug the DSP unit from the rear of the transceiver.
2. Remove the top and bottom covers (18 screws).
3. Turn the units so the bottom is up.

4. The AF unit is located in the front left hand corner.
5. Remove the 8 screws securing the AF unit to the chassis.
6. Add C191 in the position indicated in figure 2.
7. Reverse steps 1 - 5 to reassemble.

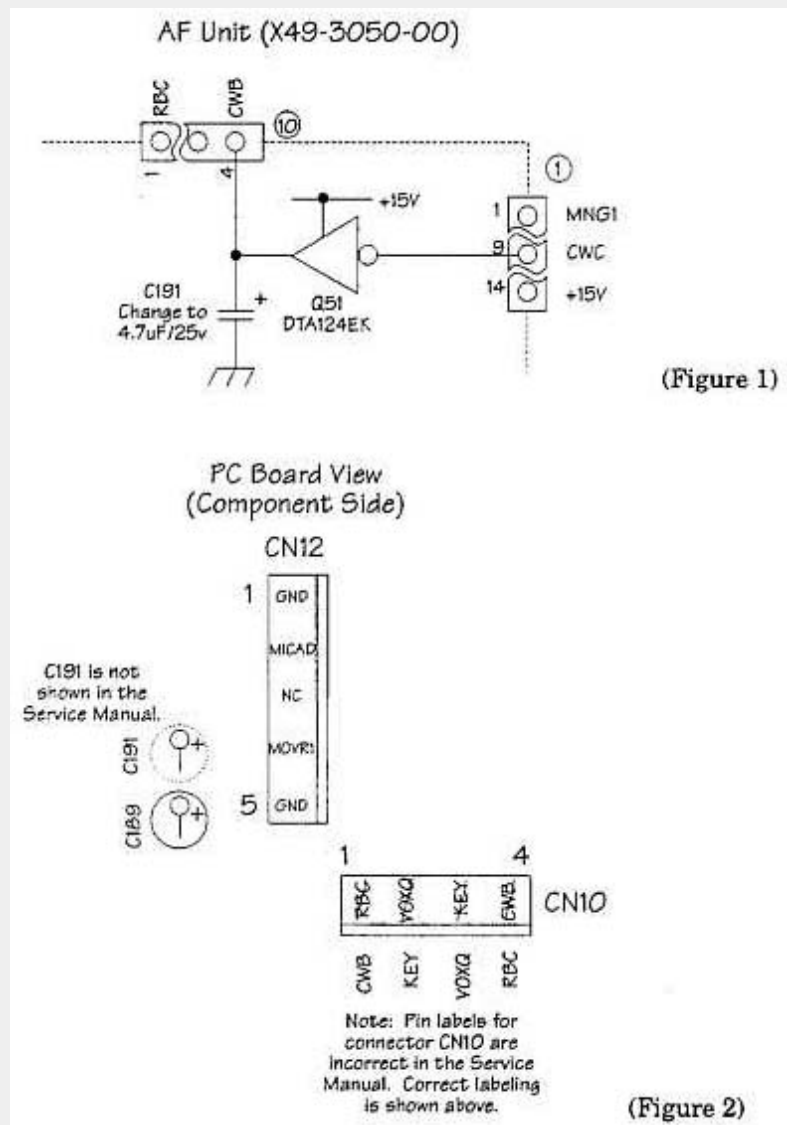

This modification may be covered under warranty.
Time required for this modification is 1 hour or less.

This modification is read 914 times.

[top of page](#)

22-04-2000

(TS-950) TS-950SDX No beep in headphones

Author: Kenwood Communication, inc.

Service Bulletin no. 999 (4 August 1992)

Several owners of the TS-950SDX have reported the absence of an audio confirmation tone when using monaural headphones. The tone is present when listening with stereo headphones but only from the right hand speaker element.

Cause:

In this design the SUB AF PA circuit supplies audio when using a monaural headphone, and the MAIN AF PA supplies audio to the right speaker of a stereo headphone. The audio confirmation tone is not applied to both the SUB AP PA and the MAIN AF PA. To simplify circuit design the tone is only routed to the MAIN AF PA. Unfortunately this left monaural users without a confirmation tone and stereo headphone users with a confirmation tone only in the right side of the headphones.

Correct action:

The following modification permits the user to hear the audio confirmation tone from both sides of a stereo headphone and from a monaural headphone.

Warning: This radio uses micro-sized surface mount component, and/or multi-layer circuit boards. *If you are not familiar with the techniques for service of this type of equipment do not attempt this modification yourself.* You will invalidate your warranty if you attempt to modify the equipment and damage the radio. If you are at all in doubt about your qualification to perform this modification you should seek qualified assistance.

Required parts:

R138: 100 Kohm radial lead ¼ watt resistor, (RD14BB2C104J)

Procedure:

1. Unplug the DSP Unit from the rear of the transceiver.
2. Remove the top and bottom covers (18 screws).
3. Remove one screw from each side of the front panel and tilt the front panel forward.
4. Add R138 from the wiper arm of VR1 to the negative side of C39 as shown in the accompanying diagram.
5. Reverse steps 1 - 3 to reassemble.

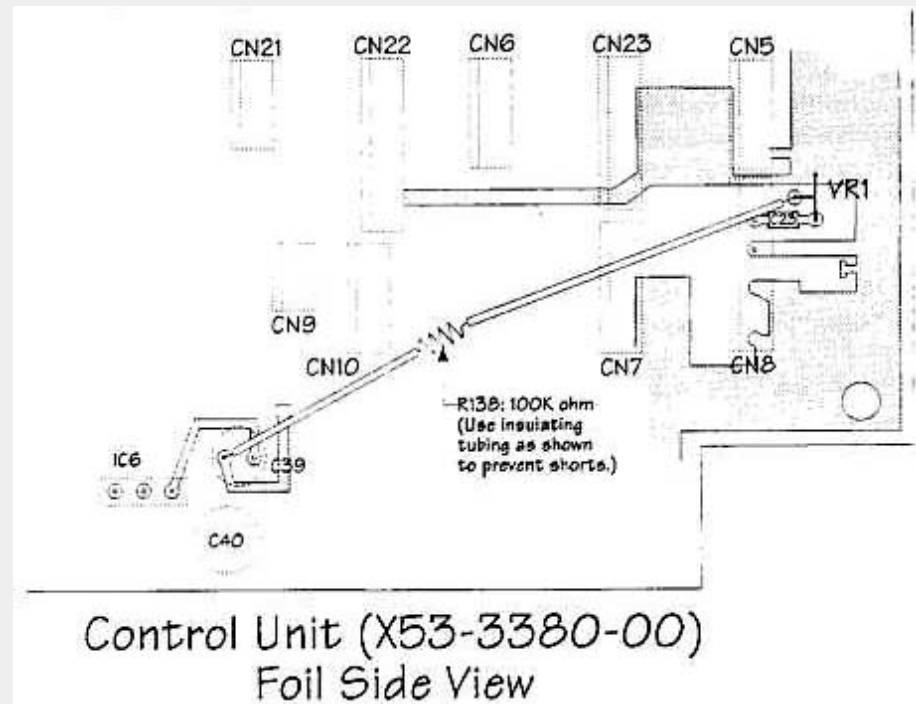

This modification may be covered under warranty.
Time required for this modification is 1 hour or less.

This modification is read 818 times.

[top of page](#)

22-04-2000

(TS-950) TS-950SDX Distorted DRU-2 TX audio

Author: Kenwood Communication, inc.

Service Bulletin no. 1001 (4 November 1992)

We have received several reports of minor distortion of the DRU-2 transmitted audio when used with the TS-950SDX. Recordings made from incoming received sources do not appear to be distorted.

Cause: This characteristic is caused by an impedance mismatch between the DRU-2 output and the input of the microphone amplifier circuit in the TS-950SDX. The following modification will correct/improve this characteristic.

Procedure:

On the Microphone Amplifier Unit (X59-3710-01), which is part of Switch Unit (A) (A41-3240-00) (H/10): (The Microphone Amplifier Unit is a small daughter board located on the switch assembly that has the Microphone Gain/Power Output Control and the Speech Processor IN/OUT controls).

1. Change chip resistor R257 from 4.7 Kohm to 8.2 Kohm (RK73FB2A822J)
2. Change chip resistor R262 from 4.7 Kohm to 1.5 Kohm (RK73FB2A152J)

Caution: This modification requires soldering equipment rated for CMOS type circuits. It also requires familiarity with surface mount soldering techniques. If you do not have the proper equipment or knowledge do not attempt this modification yourself. Seek qualified assistance.

MIC AMP (X59-3710-01)

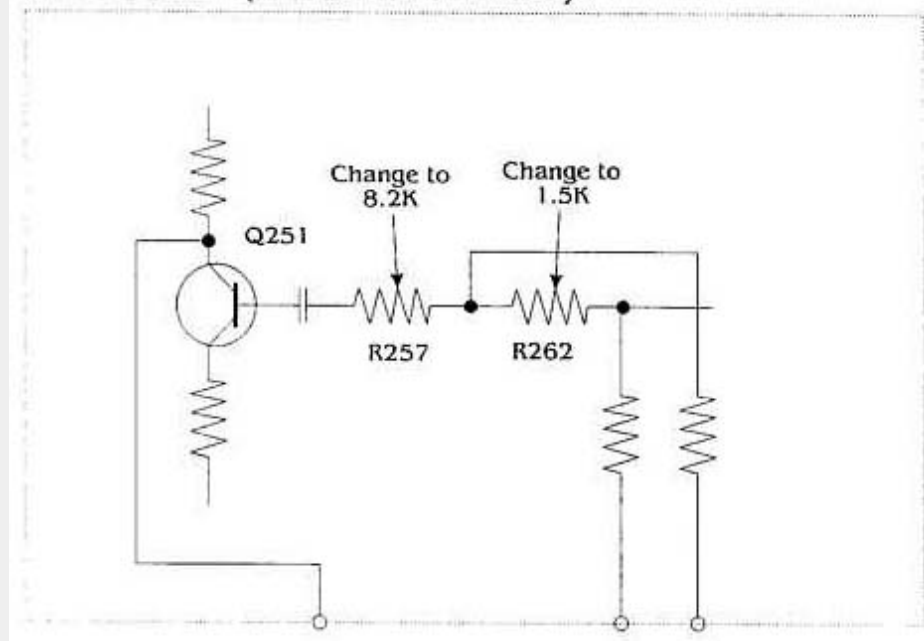

Time required for this modification is 30 minutes or less.

This modification is read 839 times.

[top of page](#)

22-04-2000

(TS-950) TS-950SDX w/K1EA Ver. 8 Program (Revised)

Author: Kenwood Communication, inc.

Service Bulletin no. 1003 (1 June 1993)

We have received several reports of the transmitter unkeying when using the K1EA Contesting program. This symptom only occurs when the TS-950SDX is used with version 8 of the K1EA program. Apparently some of the more advanced control features of this new version of the program cause the radio to think the program has unkeying. A new EPROM is available that corrects this transmitter drop out.

Parts required:

IC-19 Microprocessor, (27C512RJDVF), QTY. 1

Procedure:

1. Remove the top and bottom covers of the TS-950SDX.
2. Carefully unplug the two DSP units cables from the rear of the transceiver.
3. The front panel of the radio is designed to allow it to be tilted forward for ease of service. To tilt the front panel forward remove the screw at the top of the brackets that secure the front panel to the chassis. (Please refer to the Accompanying diagram). There is one screw on each side of the front panel.
4. Next loosen the remaining screw at the bottom of each bracket.
5. Gently pull the bottom of the front panel forward until it reaches the end of the slot in the bracket and gently pull the top of the front panel down.
6. Now look at the circuit board mounted vertically on the main chassis. This is the Digital Unit (X46-3130-11). Near the center of this board you will find the lithium battery for memory backup and a large IC installed in a socket. This is the EPROM.
7. Carefully remove the IC from the socket. Use an IC pull or very gently pry it out by slipping a small flat tool between the IC and the socket. Do not use excessive pressure as you can damage the circuit board if you pry too hard!
8. Take the new EPROM and carefully install it in the now vacant socket. Note that the notch on the end of the EPROM should be down.
9. Reverse steps 1 - 5 to reassemble. Make certain you do not pinch any wires when you return the front panel to its vertical position.
10. You will need to reset the microprocessor after the radio is reassembled. This is done by pressing and holding the A=B key while the power is turned on, and then release the key.

TS-950SDX Side view

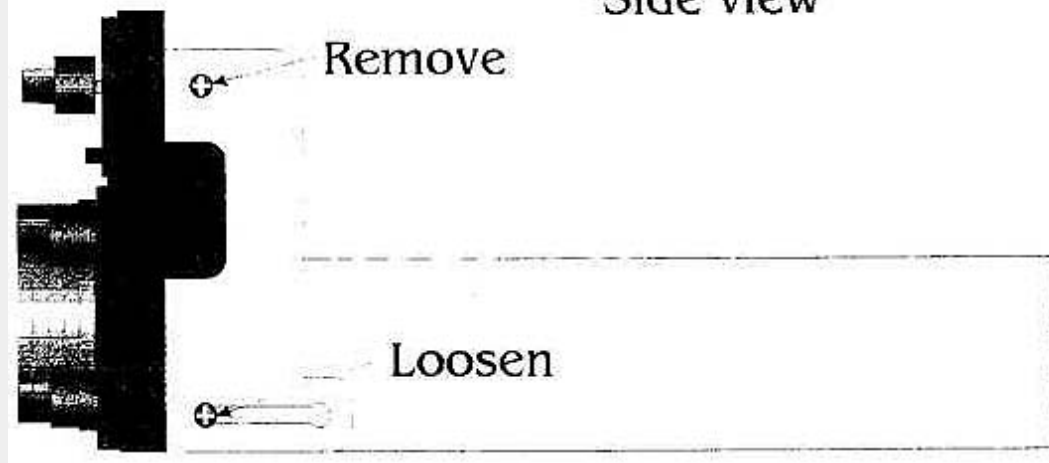

Caution: This modification requires soldering equipment rated for CMOS type circuits. It also requires familiarity with surface mount soldering techniques. If you do not have the proper equipment or knowledge do not attempt this modification yourself. Seek qualified assistance.

Time required for this modification is 30 minutes or less.

This modification is read 862 times.

[top of page](#)

22-04-2000

(TS-950) TS-950SDX Speech processor

Author: Kenwood Communication, inc.

Service Bulletin no. 1007 (25 January 1993)

Symptom:

Reports of low COMP meter sensitivity, or noise on the transmitted audio when using the speech processor is normally a result of misadjustment of the PROC IN control. This control is very sensitive and is difficult to adjust properly.

Parts required:

150 ohm chip resistor, (RK73FB2A151J)

Procedure:

Change the value of R258 in the SIG unit (X57-4130-00) from 68 ohm to 150 ohm. This will increase the available adjustment range of the PROC IN control. This will make it much easier to properly adjust the control and thus avoid overdriving the speech processor circuit.

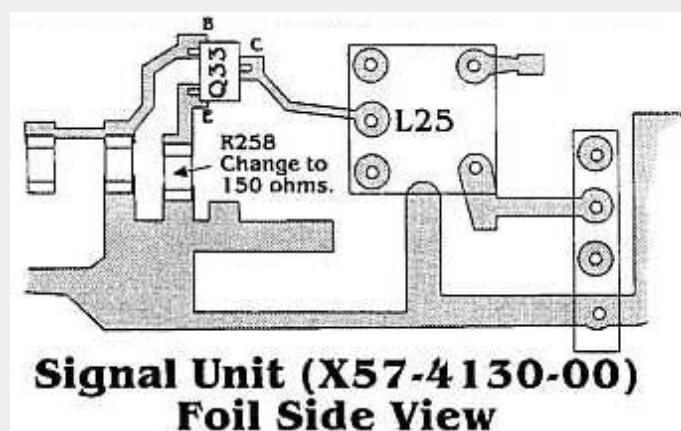

**Signal Unit (X57-4130-00)
Foil Side View**

Caution: This modification requires soldering equipment rated for CMOS type circuits. It also requires familiarity with surface mount soldering techniques. If you do not have the proper equipment or knowledge do not attempt this modification yourself. Seek qualified assistance.

Time required for this modification is 30 minutes or less.

This modification is read 898 times.

[top of page](#)

Author: Kenwood Communication, inc.

Service Bulletin no. 1009 (25 January 1993)

Symptom:

3rd order IMD figures have been noted that do not meet out standard value of -32 to -35 dB.

Cause:

We have found that this symptom can be caused by either improper bias to the final transistor and/or because of distortion inducted by the 73.05 MHz IF mixer circuit.

Parts required:

R195, R197, R198	150 ohm chip resistor	RK73FB2A151J	QTY. 3
R204	4.7 Kohm chip resistor	RK73FB2A472J	QTY. 1
R19, R20	22 ohm carbon resistor	RC05GF2H220J	QTY. 2

Procedure:

1. On the Final unit (X54-3450-00) change R19 and R20 from 10 ohm to 22 ohm. Figure 1.
2. On the IF unit (X48-3100-00): Figure 2.
 - a. Change R195 from 56 ohm to 150 ohm.
 - b. Change R197 from 220 ohm to 150 ohm.
 - c. Change R198 from 220 ohm to 150 ohm.
 - d. Change R204 from 10 Kohm to 4.7 Kohm.

No additional adjustment or modification will be required.

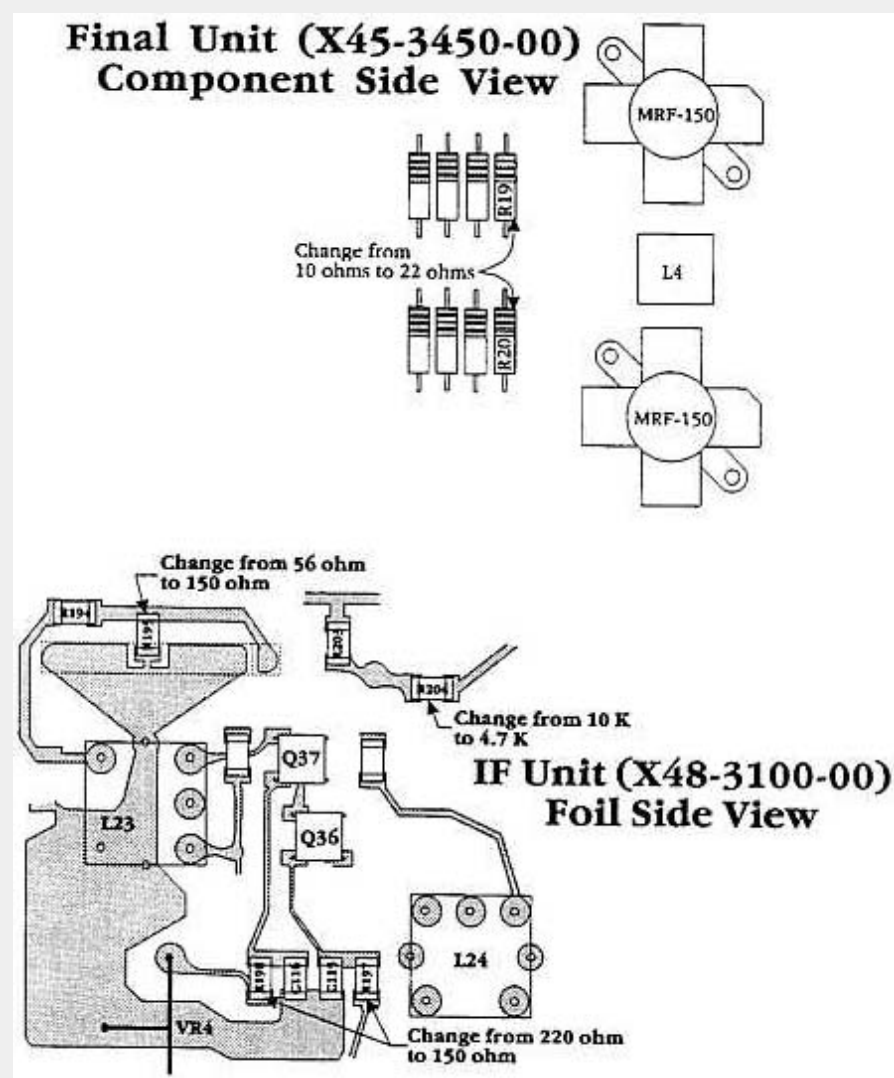

Caution: This modification requires soldering equipment rated for CMOS type circuits. It also requires familiarity with surface mount soldering techniques. If you do not have the proper equipment or knowledge do not attempt this modification yourself. Seek qualified assistance.

Time required for this modification is 1 hour or less.

22-04-2000

(TS-950) TS-950SDX Key click w/bug type keyer

Author: Kenwood Communication, inc.

Service Bulletin no. 1012 (3 May 1993)

Symptom:

A "bug" type keyer used at high keying speeds might cause a key click or chattering noise on the transmitted signal. When the internal electronic keyer is used no such chattering noise is encountered.

Cause: The internal chatter absorption filter circuit incorrectly tries to remove noise from the external keyer.

Procedure:

1. Press the MENU key one time.
2. Select MENU no. 12 by tuning the M.CH knob.
3. Press the UP key until OFF appears in the display.
4. Press the MENU key one time to exit the MANU mode.
5. Turn off the POWER SW.
6. Turn ON the POWER SW while depressing the MENU key.
7. Select MENU 69 by tuning the M.CH knob.
8. Press the DOWN key until OFF appears in the display.
9. Press the MENU key one time to exit the MENU mode.

This operation turns off the internal chatter absorption filter circuit.

Time required for this modification is 15 minutes or less.

This modification is read 790 times.

[top of page](#)

23-04-2000

(TS-950) TS-950 Hum with monitor ON

Author: Kenwood Communication, inc.

Service Bulletin no. 1016 (12 May 1993)

Symptom:

On early versions of the TS-950 series (below serial number 106xxx) a hum might be heard when the MONI function is active and headphones are connected to the PHONE jack. No hum is experienced when the MONI circuit is OFF

Cause:

This noise can only be found in the monitor circuit itself and not on the transmitted signal. We have found that the VCO shield cover for the PLL unit might be contacting the shield plate for the filter unit. This physical contact can allow a slight amount of vibration to be felt in the sub-receiver section. This vibration, combined with too much gain in the sub-receiver section contributes to the hum.

Parts required:

Qty	Description	Kenwood Part No.	Circuit description
4	Low profile PLL Unit cover screws	N35-2640-05	NA

Procedure:

1. On the IF unit (X48-3060-00) adjust VR-1 to the point the audio output just decreases when the MONI circuit is activated.
2. Replace the screws on the VCO unit shield case with the new low profile screws.

Time required for this modification is 15 minutes or less.

This modification is read 803 times.

[top of page](#)

23-04-2000

(TS-950) TS-950 Noise with Sub-Band noise blanker ON

Author: Kenwood Communication, inc.

Service Bulletin no. 1017 (13 May 1993)

Symptom:

Noise is generated when NB1 is switched on for the sub-receiver.

Cause:

Switching noise from the noise-blanker gate enters the AF amplifier via the +15 V line causing the noise.

Parts required:

Qty	Description	Kenwood Part No.	Circuit description
1	100 μ F, 16 V electrolytic capacitor	CE04KW1C101M	NA
1	120 ohm resistor	RD14BB2B121J	NA

Procedure:

1. Cut the pattern of the 15 V line on the IF unit (X48-3060-00) component side, near Q34's emitter and add the 120 ohm resistor as shown in the accompanying diagram.
2. Add the electrolytic capacitor as shown in the diagram. Quickly solder the negative lead to the metal shield of L28.

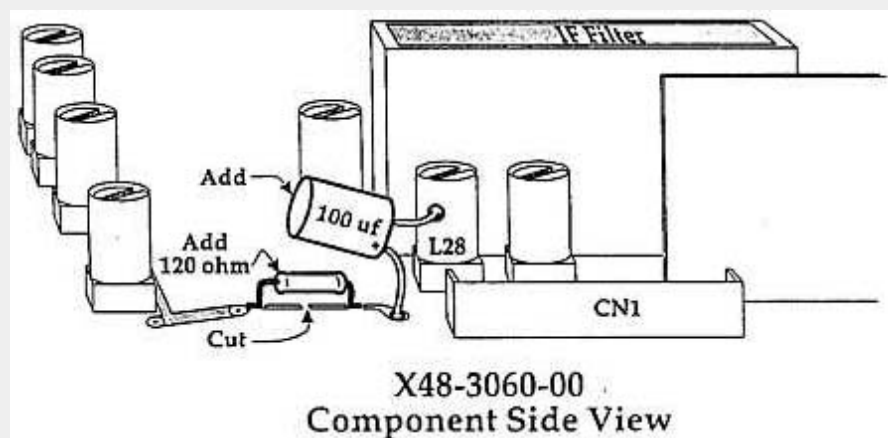

Time required for this modification is 15 minutes or less.

This modification is read 788 times.

[top of page](#)

23-04-2000

(TS-950) TS-950 14.200 MHz transmit spur

Author: Kenwood Communication, inc.

Service Bulletin no. 1018 (14 May 1993)

Symptom:

A close-in transmit spur might be present on early model TS-950(S) (serial number 1010xx and below) transceivers when operating at a dial frequency of approximately 14.200 MHz. This spur is seen approximately -40 to -50 dB down from the fundamental.

Cause:

The output from the mixer (IC12) which generates the final PLL loop comparison frequency for the AF unit contains harmonic radiation at approximately 36 to 68 MHz.

Parts required:

Qty	Description	Kenwood Part No.	Circuit description
1	Broad band transformer	L19-0346-05	L15
1	.001 μ F 50 V capacitor	CK45B1H103K	C127

Procedure:

1. Solder the primary of the transformer to pins 3 and 13 of IC12. You will have to bend the terminals slightly.
2. Solder the secondary of the transformer to pin 1 and 14 of IC12.

3. Remove chip capacitor C127 from the foil side of the board.
4. Connect pin 14 of IC12 to the ground pattern.
5. Add the new C127 from pin 1 of IC12 to L10 as shown in the accompanying illustration.

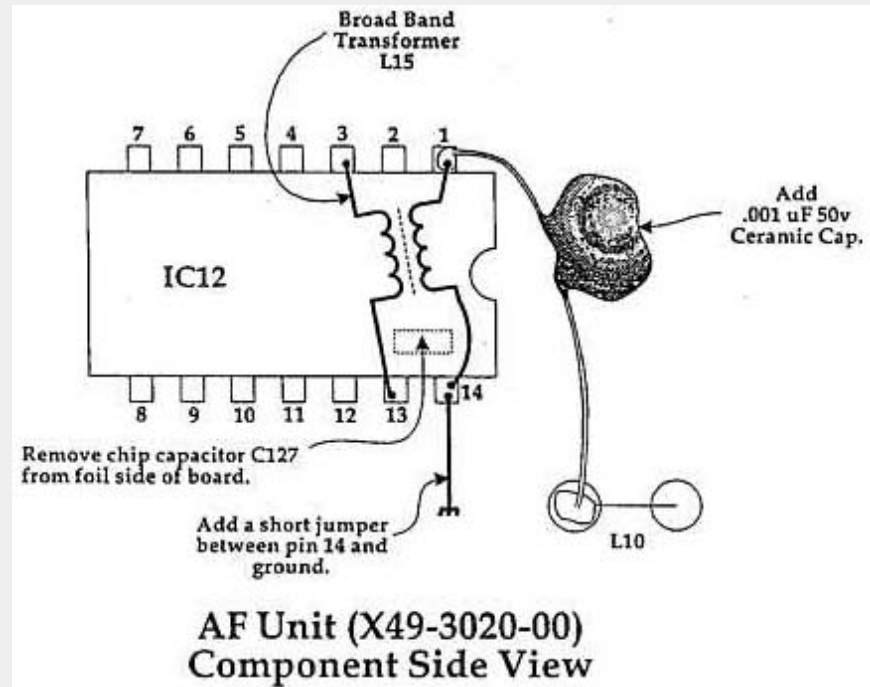

Caution: This modification requires soldering equipment rated for CMOS type circuits. It also requires familiarity with surface mount soldering techniques. If you do not have the proper equipment or knowledge do not attempt this modification yourself. Seek qualified assistance.

Time required for this modification is 30 minutes or less.

This modification is read 794 times.

[top of page](#)

23-04-2000

(TS-950) TS-950 Low power output after temp. protection

Author: Kenwood Communication, inc.

Service Bulletin no. 1019 (14 May 1993)

Symptom:

After transmitting for approximately 2 hours at 50% duty with 150 watts output the temperature protection circuit activates reducing the output power to about 50 watts. Normally, full output power will be restored after the fans have had a chance to cool things down. Occasionally the power output will not return to normal, even after extended receive operations.

Cause:

The temperature sensor is attached to the main transformer and is set to activate at 80°C. This setting was selected to reduce power before the internal fuse on the transformer opens.

Correct action:

After through testing, we have found that the temperature sensor should be set to 90°C to allow proper return to full power transmit. This setting will also allow the radio to be used at higher ambient room temperatures without worrying about the power output dropping in the middle of a QSO.

Parts required:

Qty	Description	Kenwood Part No.	Circuit description
1	90°C Thermal switch	S59-1416-05	S1

Caution: This modification requires soldering equipment rated for CMOS type circuits. It also requires familiarity with surface mount soldering techniques. If you do not have the proper equipment or knowledge do not attempt this modification yourself. Seek qualified assistance.

Time required for this modification is 30 minutes or less.

This modification is read 822 times.

[top of page](#)

23-04-2000

(TS-950) TS-950 Infinite SWR at beginning of transmission

Author: Kenwood Communication, inc.

Service Bulletin no. 1020 (14 May 1993)

Symptom:

During "Full Break-in" operation the SWR meter shows infinite SWR at the beginning of transmission. This results in a reduction of the transmitter power, followed by a gradual increase to normal full power. This symptom does not occur with the antenna tuner set to "THRU".

Cause:

Normally the RCB line should be 0 Vdc at the beginning of transmit operations. We have found that this does not always occur. The length of time required for transmit power to return to normal is directly related to the time constant of capacitor C128 on the RXB line.

Correct action:

Removing this capacitor corrects the above symptom, but might affect the receiver sensitivity at a dial frequency of 100 KHz. This action is only recommended if the symptom is actually present. Do not modify the unit if the symptom is absent.

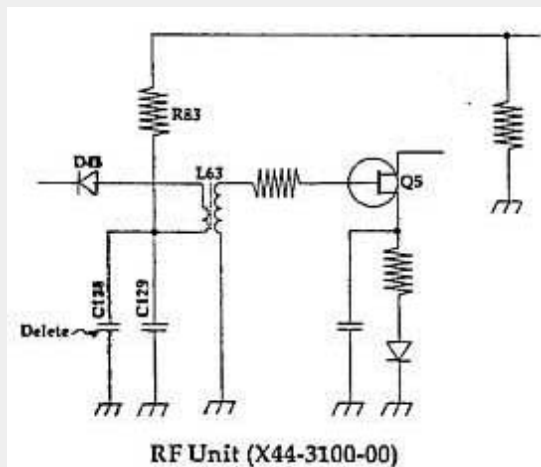

Caution: This modification requires soldering equipment rated for CMOS type circuits. It also requires familiarity with surface mount soldering techniques. If you do not have the proper equipment or knowledge do not attempt this modification yourself. Seek qualified assistance.

Time required for this modification is 30 minutes or less.

This modification is read 843 times.

[top of page](#)

23-04-2000

(TS-950) TS-950 Smoke from antenna tuner unit

Author: Kenwood Communication, inc.

Service Bulletin no. 1021 (14 May 1993)

Symptom:

When tuning into an antenna with high SWR the SWR meter reading becomes unstable and a small amount of smoke is seen coming from the antenna tuner.

Cause:

One of the 3 x 4 self tapping screws that is used to secure the AT unit hinge can occasionally damage the insulation on the brown lead wire. When the tuner is then load into a high SWR the high reflected voltage causes the lead to head up, which further damages the insulation. Eventually the insulation breaks down completely and the wire shorts to the screw causing the lead to overheat and smoke to emanate from the area.

Correct action:

Cut a 12 cm long piece of the fiberglass insulating sleeve and install it over the brown lead wire to prevent shorting.

Parts required:

Qty	Description	Kenwood Part No.	Circuit description
12 cm	Fiberglass insulating sleeve	212-3502-05	W101

(Note: The insulating sleeve must be ordered in increments of 1 meter or greater).

Time required for this modification is 30 minutes or less.

This modification is read 878 times.

[top of page](#)

23-04-2000

(TS-950) TS-950S/SDX Transmit spur

Author: Kenwood Communication, inc.

Service Bulletin no. 1024 (27 May 1993)

Symptom:

A transmitter spur might be present at a dial frequency of xx.xx1 MHz. This spur ($f_0 \pm 1$ KHz) is quite small (-55 dB relative to f_0) but might become noticeable when the transceiver is used with a linear amplifier.

Cause:

The transmitted signal enters pin 5 of IC11 which is in the last PLL loop in the AF unit due to RF feedback. This pin is the input for the 10 MHz Ref. Osc. signal from the CAR unit. IC11 is the source of the spurious signal since both the band and 10 MHz frequencies are divided by the 500 KHz comparison frequency supplies by IC11.

Correct action: To reduce this RF feedback increase the Ref. Osc. level from .2 V to .7 V ms by adding the accompanying circuit to the input of IC11.

Parts required:

Qty	Description	Kenwood Part No.	Circuit description
1	12 μ H Ferri-inductor	L40-1201-17	NA
1	10 pF Chip capacitor	CC73FCH1H100J	NA
1	16 pF Chip capacitor	CC73FCH1H160J	NA

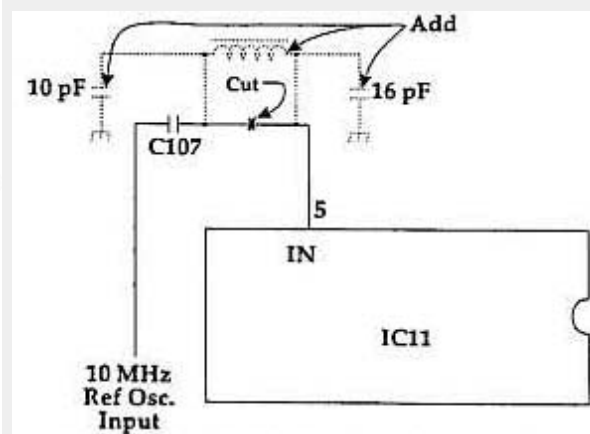
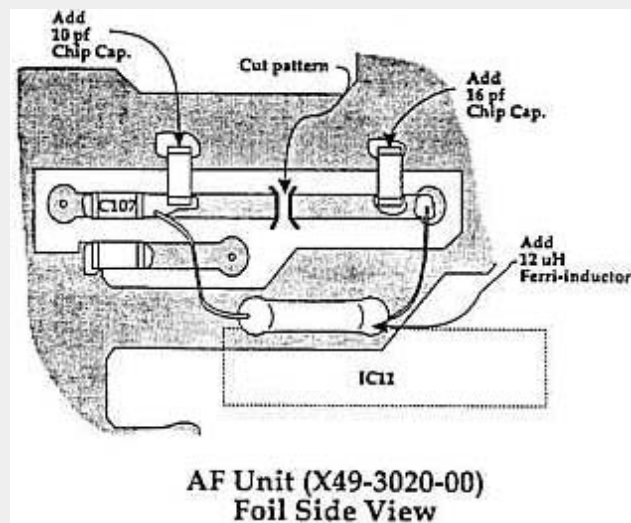

Caution: This modification requires soldering equipment rated for CMOS type circuits. It also requires familiarity with surface mount soldering techniques. If you do not have the proper equipment or knowledge do not attempt this modification yourself. Seek qualified assistance.

Time required for this modification is 30 minutes or less.

This modification is read 888 times.

[top of page](#)

23-04-2000

(TS-950) TS-950SDX "click noise" with NOTCH ON

Author: Kenwood Communication, inc.

Service Bulletin no. 1026 (7 June 1993)

Symptom:

A click noise might be generated when receiving a strong signal (S-0 or above) when the NOTCH is ON and the Notch Control is turned away from the notch point.

Corrective action:

Lengthening the AGC release time of the IF Amp just before the NOTCH circuits will correct this symptom. The enclosed modification has been designed to change the time constant only when the NOTCH circuit is activated. Do not install this modification on sets that do not exhibit this symptom as the AGC FAST time constant affected by this change.

1. Cut the printed circuit foil pattern between the test point (TP) and gate 2 of Q2 as shown.
2. Install the 47 Kohm chip resistor from TP tp gate 2 of Q2.

3. Add a 0.047 μ F ceramic capacitor as shown in the accompanying illustration.

4. Add the DTC124ES transistor as show.

Note: The .047 μ F capacitor and the digital transistor must be connected together as shown and installed so that they do not touch the surrounding board patterns.

5. Install a jumper wire from the base of the digital transistor to pin number 6 of CN14.

Parts required:

Qty	Description	Kenwood Part No.	Circuit description
1	0.047 μ F capacitor	CK45B1H473Z	NA
1	Digital transistor	DTC124ES	NA
1	47 Kohm chip resistor	RK73FB2A473J	NA

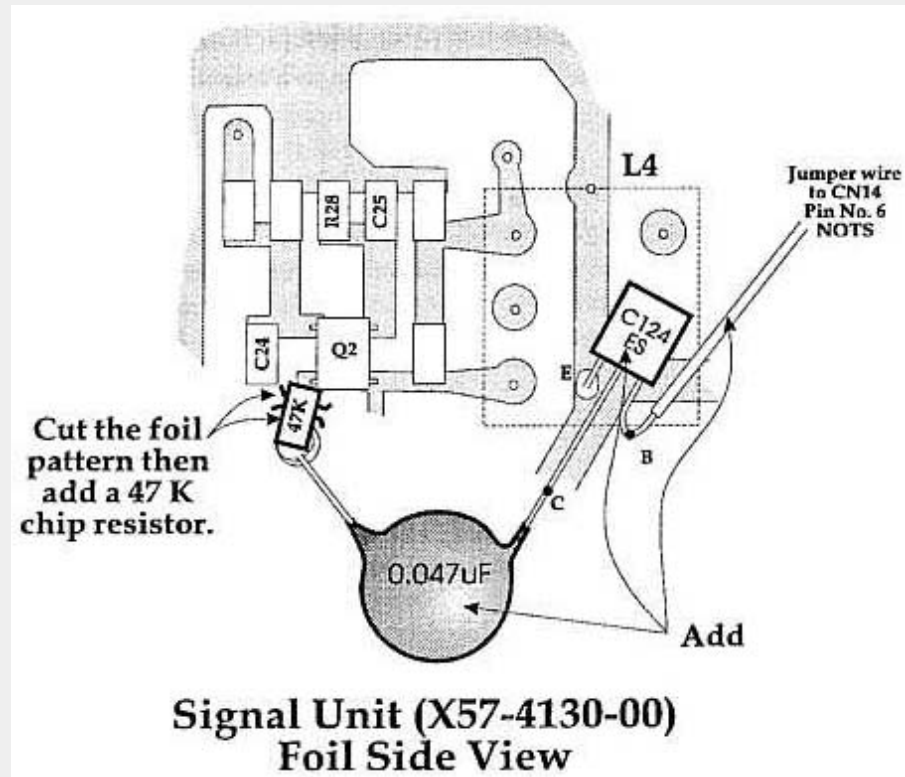

Caution: This modification requires soldering equipment rated for CMOS type circuits. It also requires familiarity with surface mount soldering techniques. If you do not have the proper equipment or knowledge do not attempt this modification yourself. Seek qualified assistance.

Time required for this modification is 30 minutes or less.

This modification is read 814 times.

[top of page](#)

23-04-2000

(TS-950) TS-950SDX YG-455S-1 Installation note

Author: Kenwood Communication, inc.

Service Bulletin no. 1043 (28 March 1994)

Symptom:

When the YG-455S-1 is installed, the LSB audio is slightly off pitch. This characteristic is corrected using the "Service Adjustment" menu. Early models of this transceiver did not make this adjustment available the individual operator unless they had access to a service manual.

Countermeasures:

A menu option has been added to Menu 07 on late versions of the transceiver which allows the individual operator to "correct" this audio shift. This has been accomplished by changing the program of the ROM chip IC-19 on the Digital unit X46-3130 1/2, and by updating the operators manuals. Installing the new ROM on early versions of this transceiver will allow the operator the same convenience as provided on later serial numbered sets.

Parts required:

Qty	Description	Old part No.	New Part No	Circuit Description
1	ROM	27C512BJDUF	27C512BJDUG	IC-19
		or		
1	ROM	27C512RJDVF	27C512BJDUG	IC-19

Time required for this modification is 30 minutes or less.

This modification is read 875 times.

[top of page](#)

23-04-2000

(TS-950) TS-950SDX No VFO B after "split"

Author: Kenwood Communication, inc.

Service Bulletin no. 1045 (28 March 1994)

Symptom:

Using the following key sequence will result in a failure to receive on VFO B.

1. Select different frequencies for VFO A and B. (Example: 14.019 for VFO A and 14.018 for VFO B. Mode SSB, 2.7 KHz FILTER for 455 KHz and 8.83 MHz).
2. Select VFO A to RX and VFO B to TX. The press the TF-W key.
3. Press the ENT key and select a frequency in the 7 MHz band. (For example: 7.018 MHz for VFO A and 7.019 for VFO B).
4. Press the ENT key and reselect the 14 MHz band.
5. Change VFO B from TX to RX. The FILTER display for 8.83 disappears and reception is disabled on VFO B.'

Countermeasure:

Press the 8.83 MHz FILTER select key one time, or replace the ROM chip.

Parts required:

Qty	Description	Old part No.	New Part No	Circuit Description
1	ROM	27C512BJDUG	27C512BJDUJ	IC-19
		or		
1	ROM	27C512BJDVG	27C512RJDVJ	IC-19

Time required for this modification is 30 minutes or less.

This modification is read 805 times.

[top of page](#)

23-04-2000

(TS-950) TS-950SDX Carrier point adjustment

Author: Kenwood Communication, inc.

Service Bulletin no. 1047 (28 March 1994)

Symptom:

The background audio tone is different between the LSB and the USB mode, when no signal is present, i.e. the carrier point is incorrect. Occasionally, this tone is still different after adjustment per the service manual, specifically Item 9 on page 196.

Countermeasure:

Change the adjustment procedure for Item 9 as follows:

Test Equipment

- Two RF signal generators with good frequency accuracy.
- A two-signal combiner.
- An oscilloscope.

Preparation:

1. Adjust the two signal generators for equal output levels.
2. Connect the test equipment as shown in the accompanying diagram.
3. Set the frequency of SSG1 to 1.850.2 MHz.
4. Set the frequency of SSG2 to 1.852.8 MHz.

5. Fine tune the output levels of the two SSG's for a good two-tone output on the oscilloscope (Figure 3).

Adjustment Procedure:

1. Connect the transceiver and the test equipment as shown in figure 2.
2. Select the adjustment Mode on the transceiver by pressing and holding the 3 and 9 keys on the keypad while the POWER is turned on.
3.
 - Set the output of the two signal generators for a - 73 dBm level.
 - Set the SSB SLOPE TUNE control to the NORMAL position.
 - Set the AGC to AUTO
 - Select MENU 00 using the M.CH/VFO knob.
 - Select USB mode.
 - Press the 8.83 MHz filter key until there is no indicator illuminated (no filter).
 - Press the 455 KHz filter key until 2.7 K appears in the display.
 - Set the frequency to the transceiver to 1.850.0 MHz.
 - Adjust the TX VFO/SUB encoder control until the waveforms displayed on the oscilloscope cross as shown in figure 3.
4.
 - Switch to LSBV.
 - Press the 8.83 MHz filter key until 6 KHz appears in the display.
 - Leave the 455 KHz filter set at 2.7 KHz.
 - Select a dial frequency of 1.853.0 MHz.
 - Adjust the TX VFO/SUB encoder control until the waveforms displayed on the oscilloscope cross as shown in figure 3.
5.
 - Select MENU 01.
 - Switch to USB.
 - Press the 8.83 MHz filter key until 2.7 KHz appears in the display.
 - Leave the 455 KHz filter set at 2.7 KHz.
 - Select a dial frequency of 1.850.0 MHz.
 - Adjust the TX VFO/SUB encoder control until the waveforms displayed on the oscilloscope cross as shown in figure 3.
6.
 - Select LSB.
 - Select a dial frequency of 1.853.0 MHz.
 - Both filters should remain at 2.7 KHz.
 - Adjust the TX VFO/SUB encoder control until the waveforms displayed on the oscilloscope cross as shown in figure 3.

Note: This completes the adjustment.

7. To return to the normal display and save these setting you should press the CLR key one time.

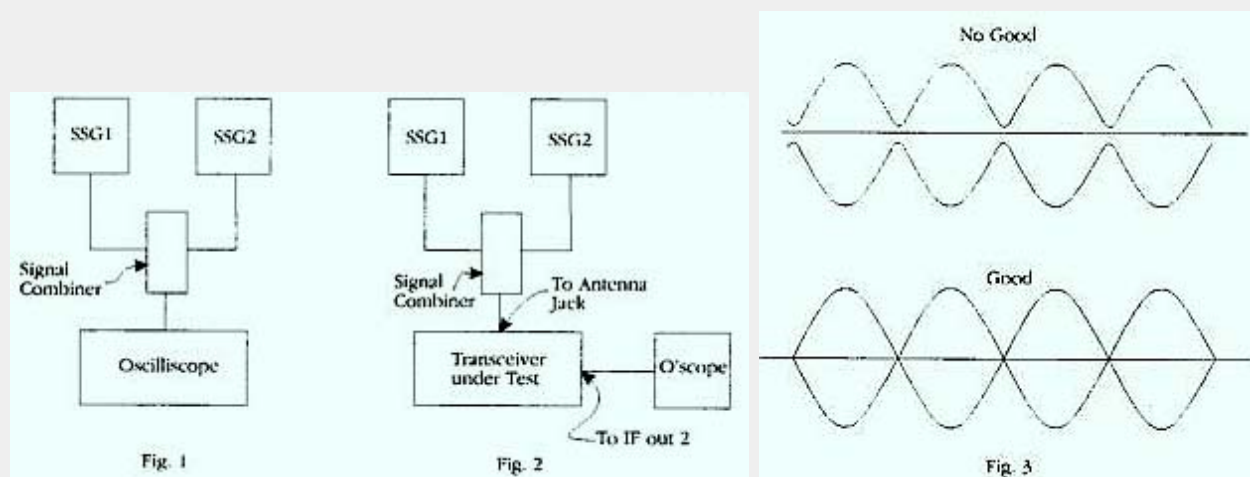

Time required for this modification is 60 minutes or less.

23-04-2000

(TS-950) TS-950SDX Sub band residual noise

Author: Kenwood Communication, inc.

Service Bulletin no. 1050 (28 March 1994)

Symptom:

The level of residual noise (AF VOL at Min) on the SUB band is slightly higher than that of the MAIN band. This is especially true at audio frequencies of around 50 Hz, as viewed on a spectrum analyzer. As a result the SUB receiver is more susceptible to motor noise, such as might be generated by fans, refrigerators, etc.

Countermeasure: Replacing the Control unit electrolytic capacitors (C33, C34, and C39) with Tantalum capacitors, and adding the bypass capacitor to the Switch unit reduces or eliminates this symptom.

Parts required:

Qty	Description	Kenwood Part No.	Circuit Description
1	0.1 μ F 35 V Tantalum capacitor	C92-0001-05	C33
1	1.0 μ F 16 V Tantalum capacitor	C92-0004-05	C34
1	10 μ F 16 V Tantalum capacitor	C92-0505-05	C39
1	.01 μ disc capacitor	CK45B1H103Z	NA

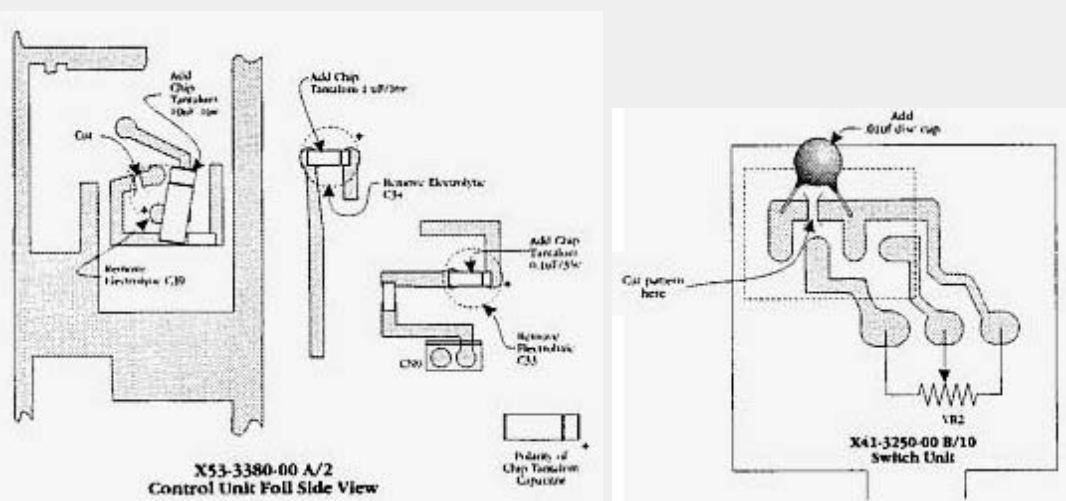

Caution: This modification requires soldering equipment rated for CMOS type circuits. It also requires familiarity with surface mount soldering techniques. If you do not have the proper equipment or knowledge do not attempt this modification yourself. Seek qualified assistance from your closest Kenwood Service Center (Long Beach, CA, or Virginia Beach, VA).

Time required for this modification is 60 minutes or less.

This modification is read 822 times.

[top of page](#)

23-04-2000

(TS-950) TS-950SD 18.115 MHz spur

Author: Kenwood Communication, inc.

Service Bulletin no. 1052 (28 March 1994)

Symptom:

Transmitting on 18.1145 MHz causes a spur to appear at 18.1150 MHz with the antenna tuner on.

Corrective Action: Add the low pass filter shown in the accompanying diagram to the input circuit of mixer Q41 on the IF unit (X48-3060-00). This filter will increase the attenuation by approximately 20 dB.

Parts required:

Qty	Description	New Part No.	Circuit Description
1	220 μ H inductor	L40-2211-14	NA
1	220 pF chip capacitor	CC73FSL1H221J	NA

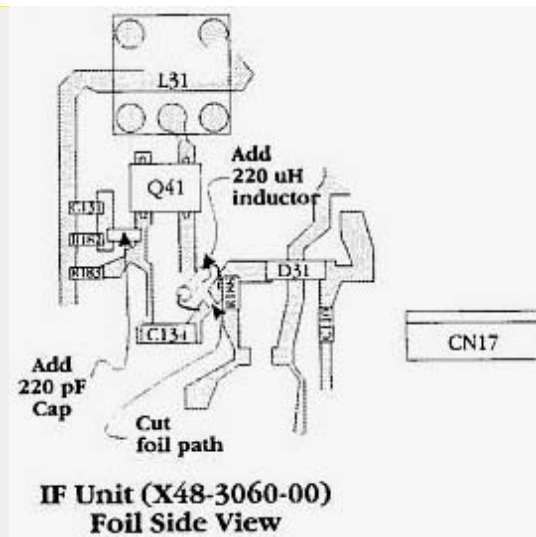

Caution: This modification requires soldering equipment rated for CMOS type circuits. It also requires familiarity with surface mount soldering techniques. If you do not have the proper equipment or knowledge do not attempt this modification yourself. Seek qualified assistance from your closest Kenwood Service Center (Long Beach, CA, or Virginia Beach, VA).

Time required for this modification is 60 minutes or less.

This modification is read 802 times.

[top of page](#)

23-04-2000

(TS-950) TS-950SDX Change of Gate resistor type

Author: Kenwood Communication, inc.

Service Bulletin no. 1053 (28 March 1994)

Symptom:

If the final amplifier is operated at excessive transmit levels (over 150 watts output) the final FET's may fail and short from Source to Gate. If this occurs, the bias resistors used in this circuit may be damaged and cause a large amount of smoke to be emitted from the final compartment.

Corrective Action:

Change the carbon type resistor used for R17 and R18 to the fuse type resistors specified below. This will prevent an unpleasant odor and smoke from the final compartment.

Parts required:

Qty	Description	New Part No.	Circuit Description
2	100 ohm ½ watt fuse resistors	R92-1310-05	R17, R18

Procedure:

Remove the old resistors from their locations on the circuit board and install the new resistors directly between the Gate and Source of the final transistors. (see the illustration below).

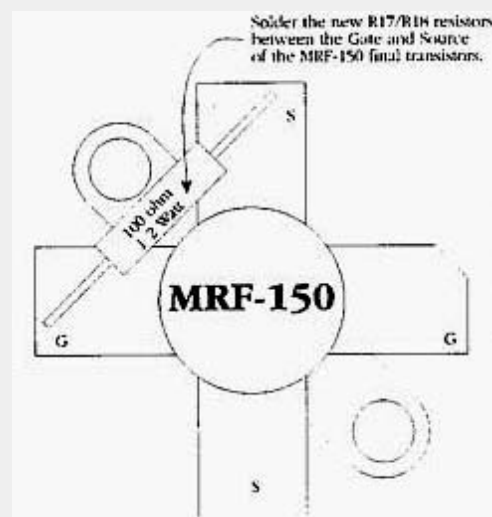

Caution: This modification requires soldering equipment rated for CMOS type circuits. It also requires familiarity with surface mount soldering techniques. If you do not have the proper equipment or knowledge do not attempt this modification yourself. Seek qualified assistance from your closest Kenwood Service Center (Long Beach, CA, or Virginia Beach, VA).

Time required for this modification is 60 minutes or less.

20-01-2001**(TS-950) Countermeasure against cold solder joint at the resistor block; CP1-CP4 in the PLL unit.**

Phenomenon:

1. Sub-band reception is deteriorate or receiving audio is intermittent distortion.
2. Transmission monitoring audio is distorted.

If you find the malfunction at stated above, take the following procedure.

Cause:

Cold solder joint of resistor block; CP1-CP4 in the PLL unit (X50-3170-00). In the manufacturing process, the temperature in the reflow soldering furnace was lower than specified and the connection was insufficient.

1. Temporary: Add more solder to the resistor block; CP1-Cp4 (at all pins) in measure the PLL unit (X50-3170-00).
2. Permanent: review the whole temperature control system of the reflow furnace to manufacture the Printed Circuit Board at more adequate temperature.

PC Board (Component side view).

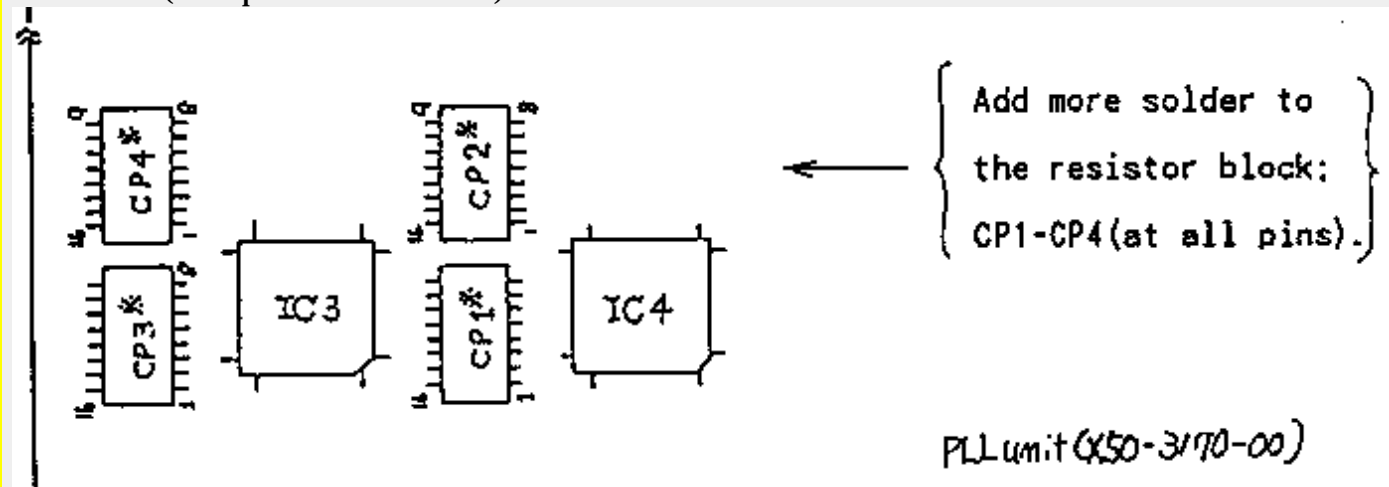
**02-12-2001****(TS-950) Kenwood TS-950S & TS-950SD RF gain mod**

Author: Kenwood & NOSS

This mod is courtesy of Kenwood

The Kenwood TS-950S and TS-950SD HF transceivers are fine radios. However, many, if not all, of them were produced with a design flaw which allows the RG GAIN control to cease function in the presence of a strong signal IF the AGC has been turned OFF.

One common scenario goes something like this:

1. Tuning around any band, in CW mode, with the AGC turned OFF, and using the RF GAIN to control received audio level.
2. RF Gain is set to allow moderately strong signals (c. S-9) to be received without excessive audio output (comfortable listening level).
3. Tune through a strong (S-9 + 10dB or more) signal. The receiver loses all control of the RF GAIN. The control becomes virtually useless you either tune off the strong signal or the signal stops, at which point the RG GAIN control again becomes usable. Immediately switching the AGC back ON, will also allow you to regain control of the RF GAIN, but if you again return to AGC OFF, and the signal is still present, control is again lost.

Although I have not tried it, I am told this problem can also occur in other receive modes as well.

The following document is a re-typed version of the Kenwood Mod. Any typos have been allowed to remain in the narrative of the document. The schematic has been re-drawn in order to allow you to follow the mod more easily, not because the original drawing was in error, but because it was somewhat difficult to follow the black & white line drawing.

I have also included several photos of the Signal Unit PC board to assist you in locating the portion of the PC board which will require

your attention.

Note that you will be dealing with SMT-type devices which will require a significantly higher degree of care when working with them than would be required if non-SMT devices were used. This is result of progress(???) in manufacturing. You WILL have to use a soldering iron with a very small tip, and you may have to use a magnifying lens to assist you in locating and removing the SMT devices, not to mention installing the two jumpers required by the mod. Fortunately, NO additional components are required... only a couple lengths of #24 to #30 insulated wire (for the jumpers).

Good luck - Tom Hammond NØSS n0ss@arrl.net.MODIFICATION.NET 28 Nov 2001

MODEL TS-950S & TS-950SD

No RF Gain at AGC OFF and large input.

CONTENTS

REFERENCE

Phenomena:

1. AGC is turned OFF. The RF GAIN is set maximum in the counterclockwise direction.
2. SSG is connected to the ANY pin. The SSG input is about 10dB μ .
A signal is received on the SSB mode, and it is made sure that the S-meter's pointer swings (about S-3).
3. The RF GAIN control is turned counterclockwise to set the S meter's swing to S-9.
4. The SSG input is changed from 10dB μ to 40dB μ . Then, the S meter reading zero, and the RF GAIN becomes disabled.

Cause:

Insufficient study on switching transistors Q 30 and Q 40 (these transistors operate at AGC OFF) of AGC amplifier Q 10 in the signal unit.

Countermeasure:

The circuit of the AGC amplifier Q 10 in the signal unit (X57-3380-00) is modified.

- a. Chip resistor R 135, it removed.
- b. Chip resistor R 136, is removed.
- c. Digital transistor Q 40, DTC124EK, is removed.
- d. Chip diode D25, RKZJ3.6B, is changed to chip jumper W8, (R92-0679-05).
- e. Short jumper W9, R92-1061-05, is added.

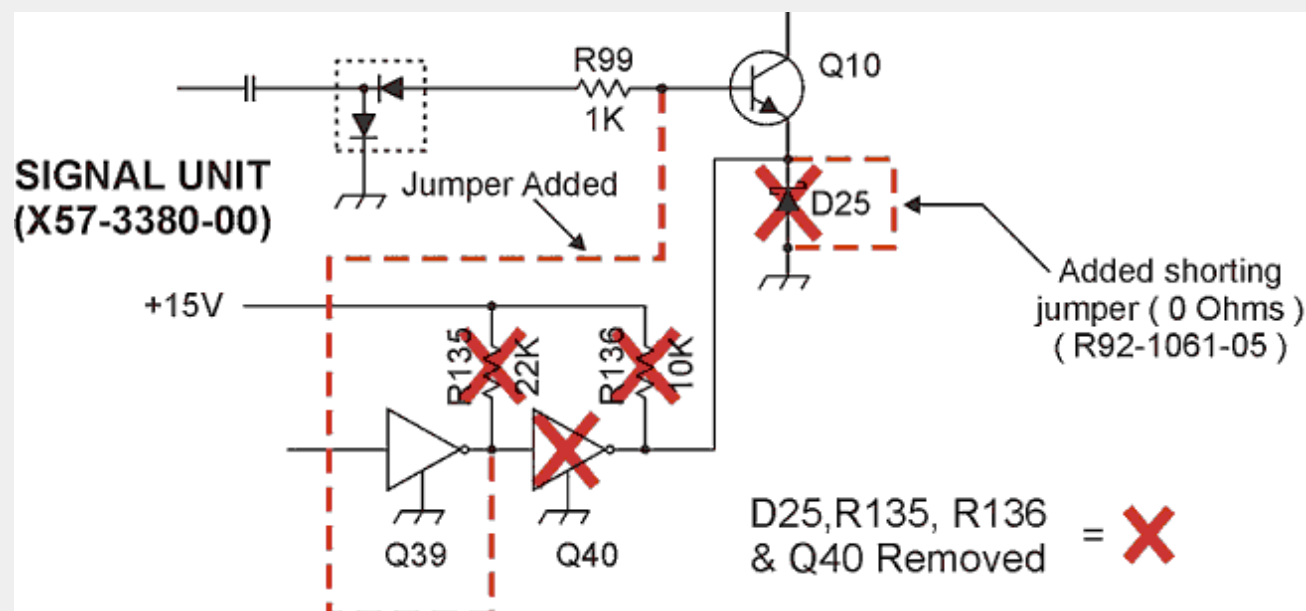

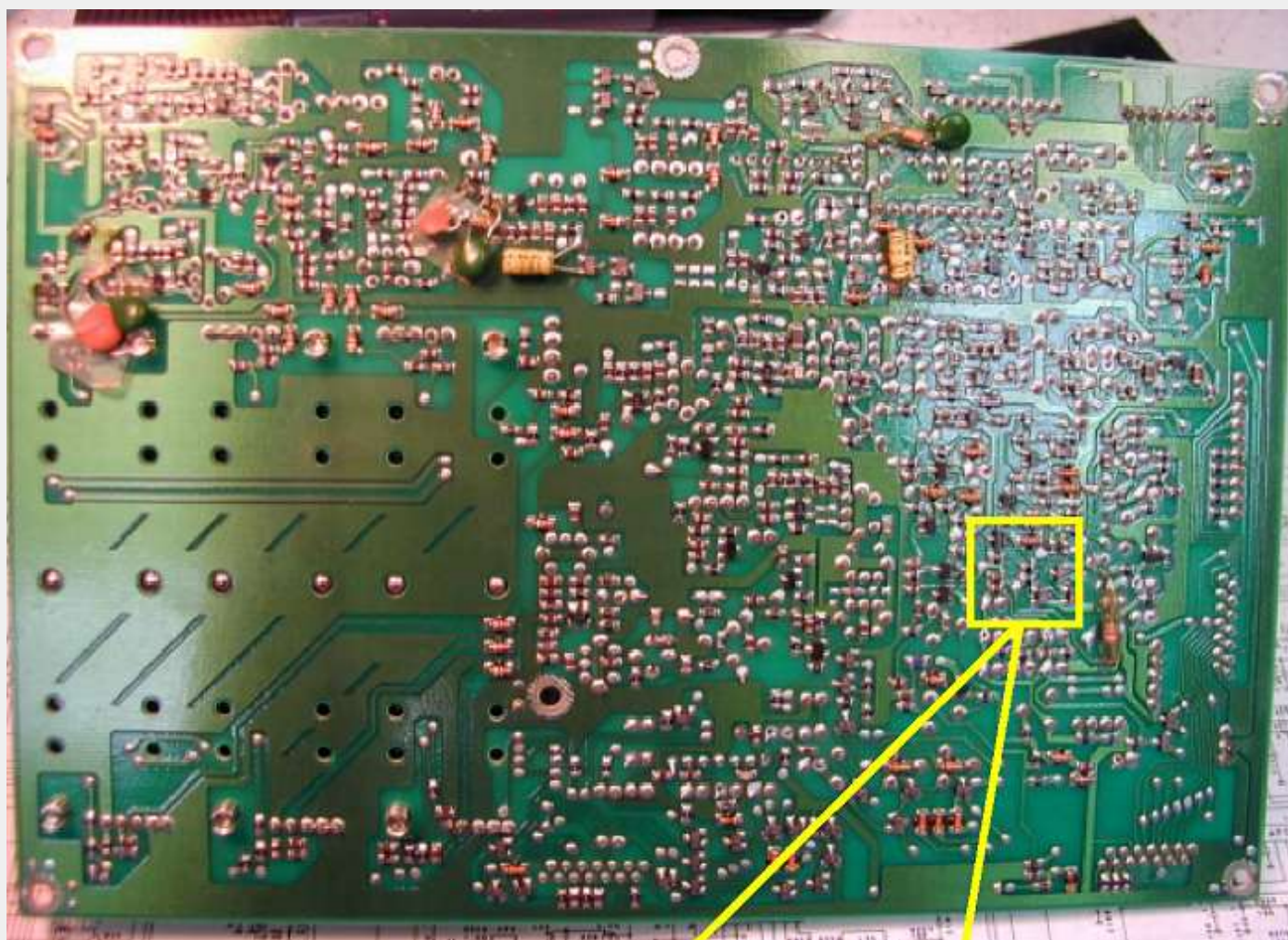
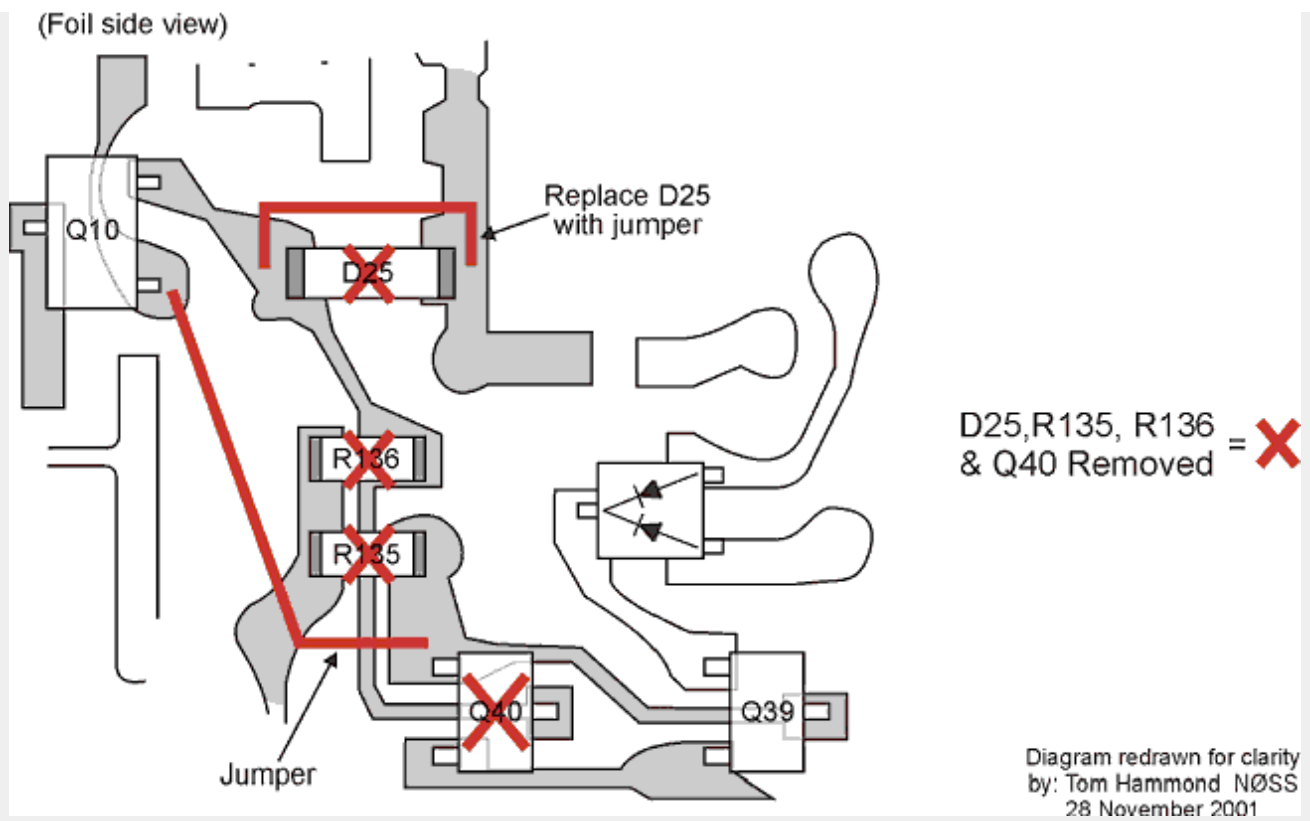

Signal unit pc board (X57-3380-00), Bottom OF TS-950SD

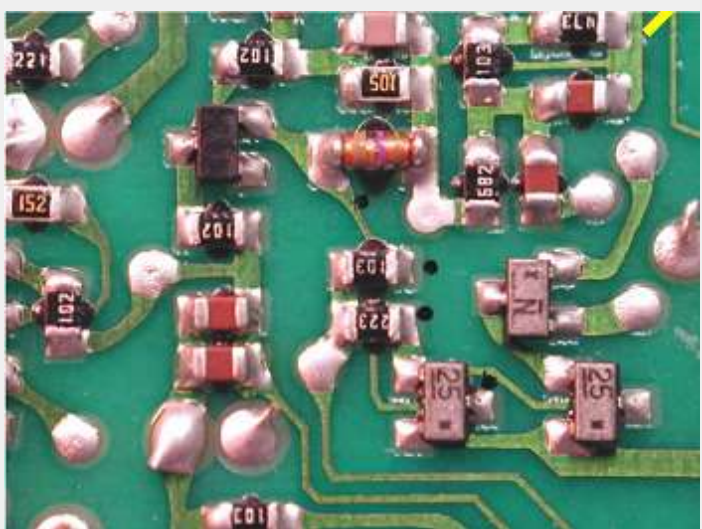

Before mod

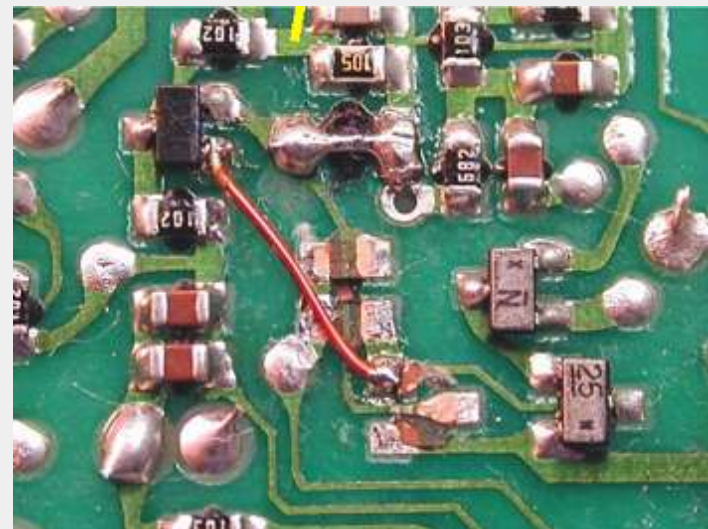

After mod

23-02-2002**(TS-950) Implementation of the K6XX QSK Waveform Mod in the TS-950SD****Author:** Tom Hammond NØSS - noss@earthlink.net.[MODIFICATION.NET](http://www.k6xx.com/ikanrite.html)

by: Tom Hammond NØSS

Bob Wolbert (K6XX) has come up with a really great modification to improve the CW waveform and character weighting in a number of commercially-made Amateur Radio transceivers. The original article on the mod, and a separate article containing a PC board design with which to implement it, are available at <http://www.k6xx.com/ikanrite.html>.

This article describes the specific steps required to implement this mod in the Kenwood TS-950SD, and assumes that the PC board design referenced above has been used to produce a PC board, and that the PC board has been populated with the required components.

READ THESE INSTRUCTIONS COMPLETELY BEFORE YOU HEAT UP THE SOLDERING IRON.

REFER TO THE SCHEMATICS IN YOUR TS-950xx MANUAL TO CONFIRM ALL CONNECTIONS BEFORE YOU ATTACH ANY WIRES TO A PC BOARD.

Step-by-Step Installation steps

1. Remove the top and bottom covers of the TS-950SD and set them aside. Don't forget to disconnect the two cables from the DSP unit before removing the bottom cover of the radio.
2. Place a protective 'blanket' or other soft material beneath the front of the TS-950SD, so that when the radio is moved and turned, you will not damage the finish on the plastic portion of the front panel.
3. On each sides of the TS-950SD chassis, just behind the front panel, you will find two Phillips-head screws which hold the front panel in place. The bottommost of the two screws, when loosened 2-3 turns, acts as a hinge for that side of the front panel, allowing it to first slide forward about 1-1/2 inches and then to tilt forward to expose the back of the front panel and the front of the sub-front panel PC boards mounted to the main chassis. The topmost of the two screws may be completely removed to allow the front panel to move. Loosen the bottom screws, remove the top screws and slide the front panel forward.

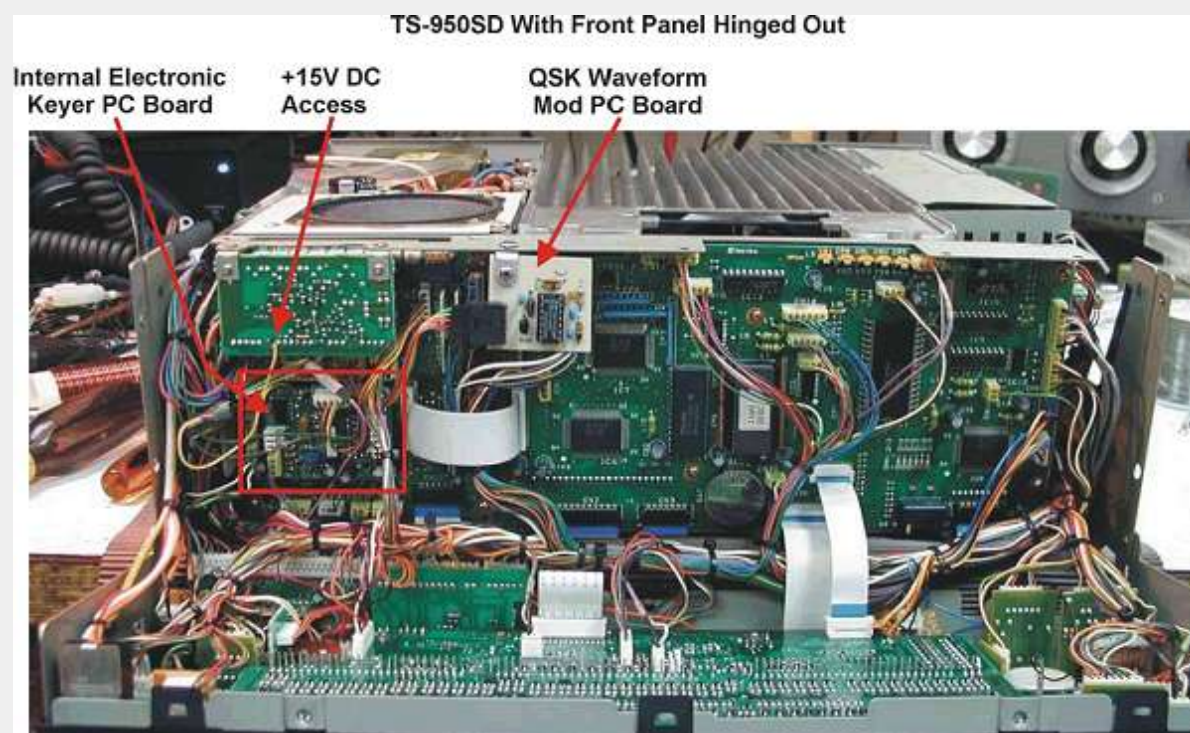

Figure 1

4. IN THE STEP WHICH FOLLOWS, BE CAREFUL TO NOT ALLOW THE FRONT PANEL TO 'FLOP' DOWN IN AN UNCONTROLLED MANNER. Should this happen, one or both of the thin white ribbon cables just to the right of center in Figure 1 may become unplugged and will require reinstallation. In this case, you must CAREFULLY pry out on the locking tabs which hold the locking mechanism of the socket and then lift the mechanism about 1/4" in order to be able to re-insert the ribbon cable. Once the cable is reinserted, press the locking mechanism back into place.
5. Slide the entire radio forward, such that the front of the radio extends off the front edge of the work surface, allowing the front panel to rotate from its normal vertical position to a horizontal position. If necessary, take steps to support the front panel at an angle no greater than 90° to the vertical.

Prepare a 6" length of 5-conductor cable to attach to the 5-pin connector on the PC board. Note that the wires for the GND, QSK, and Key Out lines will be connected to the BACK side of the TS-950SD internal Keyer PC board, while the +V and the Key In pins of the 5-pin connector must be connected to other off-board devices. As such, the +V and AUX Key In wires should be cut to 3"-4" and terminated with single-pin receptacles or pins. AMP AmpModu 0.25" pins, receptacles, and housings (Mouser 571-1021073, 571-875236, and 571-7874992) work well for this task. Use a single-pin receptacle and housing on the AUX Key In lead, and a single pin (insulated with heat-shrink-tubing) on the +V lead. The mating connections will be used on the leads coming from the external sources. Note that I added a slightly larger diameter heat-shrink tubing 'cover' to provide additional protection for the single pin connection, allowing the heatshrink tubing to slip over the single-pin housing, thus protecting the single pin lead when it is not inserted into the mating single-pin housing receptacle. This added protection can be seen in the photo above, connected to the pink wire, in the lower left quadrant of the picture. See a better example a bit later in this article when the connection of the AUX Key Input is connected to the ACC2 connector.



Figure 2

Mount the QSK mod PC board to the underside of the top lip of the chassis front, as shown in Figure 2 above, and in Figure 1, on the first page of this document.

8. To a 26" length of small diameter (#22-#24) insulated wire, attach a single pin, and insulate it in the manner described above, including the oversized heatshrink cover for the housing into which it will plug. Attach this connector to the mating single-pin housing/receptacle coming from the AUX Key In lead of QSK Mod PC board.
9. Carefully, run the free end of the 28" length of wire between the back of the front panel and the front of the facing PC boards, out the bottom of the TS-950SD.
10. Carefully fold up front panel, slide it into place, and secure it in place with the two TOP screws. There is no need to tighten the hinge screws at this time.
11. Carefully invert the TS-950 and turn it so the rear of the radio is now facing the front of your work surface.
12. Refer to Figure 3, and route the free end of the Key In lead along the side of the chassis, to the rear of the chassis. As you pass the tie-wraps which secure the other wires into bundles, take time to pass this Key In lead through the tie-wraps as well.
13. When the AUX Key In lead has been properly routed, lay it just inside the back edge of the chassis, measure the length required to attach this lead to pin 2 of the ACC2 connector (see Figure 4). SUBTRACT two inches (2") from the measured length and cut off any excess wire length. To this end, attach a single-pin receptacle and slip it into a single-pin header.
14. Attach a .001uF (50V min.) cap between pins 2 & 4 of the ACC2 jack as shown in Figure 4.



Figure 3

From the excess wire cut in step 13, measure and cut a 3" length. Strip 1/8" of insulation from both ends and tin them. On one end, install a Figure 4 single-pin receptacle and slip it into a single-pin housing. Solder the other end of this wire to pin 2 of the ACC2, on the back side of the jack.

15. To the unterminated end of the AUX Key In lead coming from the front panel, install a single pin and insulate it with heatshrink tubing. Note that the heatshrink tubing is only shrunk at ONE END, the end covering the pin itself is NOT shrunk, to allow insertion of the pin into the mating single-pin housing.
16. Turn the TS-950SD back around, so the front panel is facing the front of the work surface and tilt the front panel to the horizontal position.
17. Refer to Figure 1 and locate the internal keyer PC board. This PC board is not screw-mounted. It plugs onto two header blocks attached to the PC board in back of it. To access the keyer PC board, carefully, rock it back and forth as you pull it away from the larger PC board.
18. The keyer PC board has two (2) multi-wire header connectors attached to it. Carefully remove both of the multi-wire header connectors.



Figure 4

- Turn the keyer PC board so it's back (foil) side faces you.
21. Refer to Figure 5. At the bottom of the keyer PC board, there are six (6) pads, each immediately above a matching hole (for the

header plug pins). In the following step, pin numbering will begin with the leftmost of these six pads and progress to the right. Wires will be connected to pins 2, 3, & 6, respectively.

22. Remove 1/8" (max.) of insulation from the three unterminated leads coming from the QSK mod PC board, tin the leads (note: the insulation may recede as the ends are tinned) and clip the tinned leads to a length of 1/8"
23. Attach the wire from pin 1 (Key Out) on the QSK Mod PC board to pin 2 on the keyer PC board. BE SURE to attach the lead so the rest of the wire faces the INSIDE of the PC board.
24. Attach the wire from pin 2 (QSK/Full) on the QSK Mod PC board to pin 3 on the keyer PC board.
25. Attach the wire from pin 5 (GND) on the QSK Mod PC board to pin 6 on the keyer PC board.
26. Position the keyer PC board so that it can be reinstalled onto the header blocks on its motherboard. Arrange the wires from the QSK mod PC board such that they are well clear of the header holes on the (now) right side of the keyer board, and so they exit from the top rear of the QSK mod PC board. Reinstall the keyer PC board.

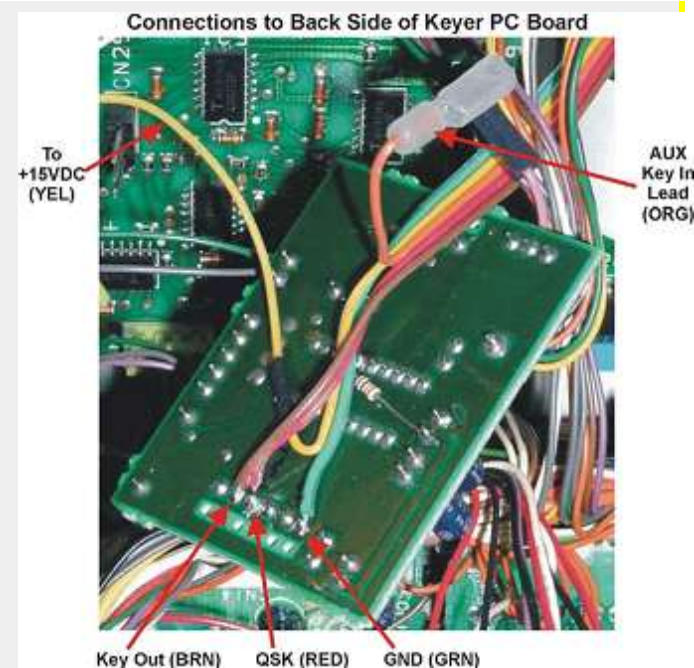

Figure 5

27. Reinstall the two multi-wire header plugs removed from the keyer PC board in step 19, above.

Cut a 3" piece of insulated wire (preferably the same color and type of wire as used for the +15VDC (+V) lead coming from the QSK mod PC board 5-pin connector. Strip 1/8" of insulation from each end of this wire and tin both ends. To one end of this wire, attach a single-pin receptacle and insert it into a single-pin housing. This will mate with the single pin plug which was created in step 6 of the instructions.

Attach the unterminated end of this wire to the +15VDC pad on the PC board immediately above the keyer PC board, see Figures 1 & 6 for the location of the PC board and for the proper pad to connect to. Also, **confirm** this connection in your TS-950 manual (schematic section).

29. Connect all of the single-pin connectors to their respective pins (+15VDC, and two connections Figure 6 (front & rear) of the AUX Key In line).



Figure 6

30. This should complete installation of the QSK Waveform Mod. However, you will still need to tweak the component values for CV and RT, and possibly CT as well. With any luck at all, you won't have to change the value of CT however.
31. If you installed a 1-Meg PC-mount trimmer pot at RT, skip to **step 33**.
32. Temporarily detach the QSK mod PC board from its mounting and tack-solder two 1" leads into the holes reserved for RT and attach a 1-Meg potentiometer (to be referred to as RT during the testing period) to these leads. Reinstall the PC board.
33. Place a 1/4" stereo plug into the KEY jack (not the AUX Key In connection at ACC2) on the rear of the TS-950. You will NOT be able to send CW via the AUX Key In connection unless the regular KEY jack has a plug in it.
34. Run the TS-950 output coax run to a dummy load though a monitor scope (or attached to an oscilloscope).
35. Connect the output of your EXTERNAL CW keyer to the AUX Key Input at ACC2 pin 2 and ground. You may need to use clip leads for this connection until you fabricate a jack to plug into ACC2 pin 2.
36. Turn the TS-950 on and set the POWER control fully CCW. Set the VOX/PTT switch to VOX, and FULL/SEMI (QSK) to SEMI.
37. Set the external keyer speed to around 30 WPM and the weighting to 50%.
38. Send a string of DITs and slowly increase the POWER output control until an output envelope is shown on the monitor scope.
39. While watching the CW waveform on the scope, adjust the Horizontal Sweep speed of the scope in order to stop two consecutive DITs on the screen.

HINT: Increase the speed of the Horizontal Sweep, to the point that one DIT wraps itself around the trace and you can then superimpose the BREAK of this DIT on top of the MAKE of the same DIT. There will a bright line through the trace, but you will be able to easily tell if the weighting is correct because a 50% weighting will cause the BREAK to end just as the MAKE begins. If the two overlap, then the weighting is too heavy. If they don't touch, then it's too light.

40. If the weighting in this mode (SEMI BREAK-IN) is too light, increase the value of CV, if it is too heavy, reduce the value of CV a bit, until you obtain a weighting ratio of approximately 50%.
41. Set the FULL/SEMI switch to FULL.
42. While sending a string of DITs, adjust the value of RT until the space between the end of one DIT and the start of the next DIT is

the same length as the length of the DIT itself.

43. Once you have successfully set the weighting, you are finished.
44. If you did not use a PC-mount pot for RT, you must now remove the temporary pot (and leads), measure the value of the pot, and replace it with a fixed resistor of the same approximate value.
45. If required, reinstall the QSK mod PC board.
46. Tilt the front panel back into place (vertical), slide it back toward the main chassis, and secure it in place with two screws at the top, on each side. Retighten (until snug only) the two hinge screws. Replace the top and bottom covers of the radio and reattach the two cables from the DSP unit on the bottom of the radio.

You are done! Whew!

Please note. This document would not have been possible without the assistance of Bob Wolbert (K6XX) who designed the original modification.

If you find errors in this document, please contact me so that I may make corrections to the instructions.

Revised: 13 April, 2001

Better QSK Waveforms

by: Bob Wolbert, KM

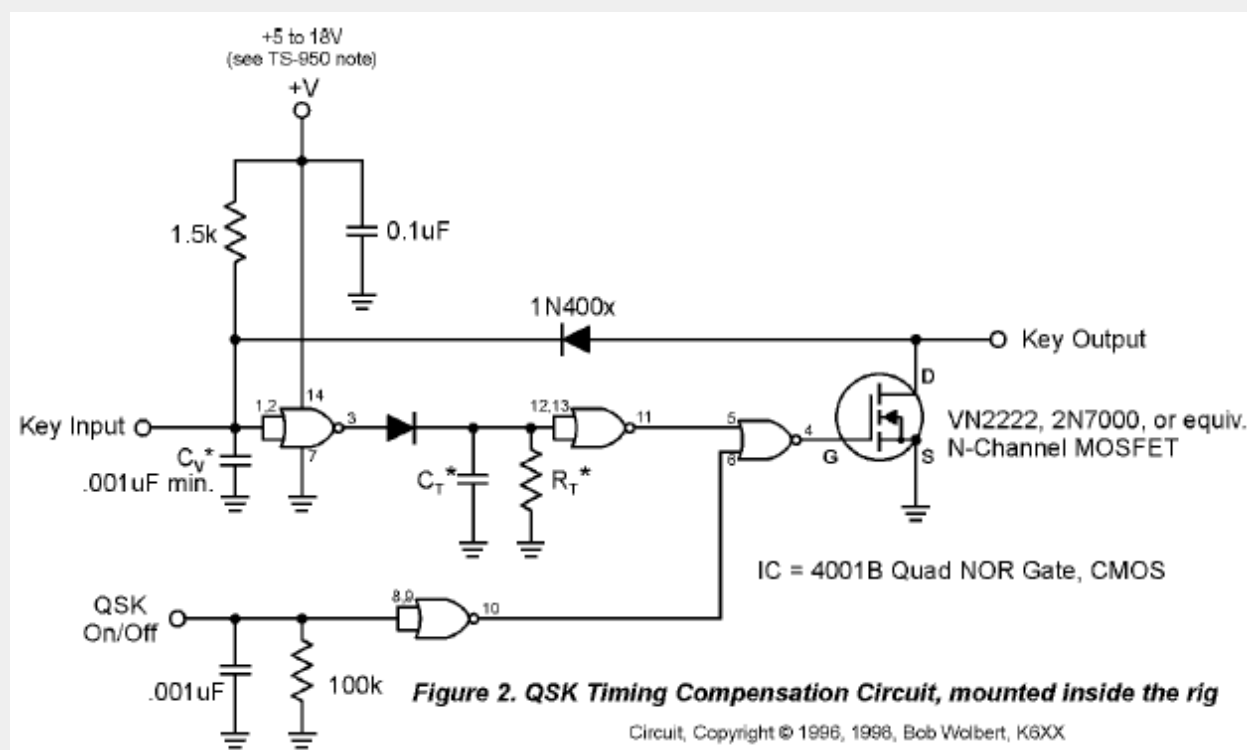

Capacitors, Connector(s) & Notes

- .001 uF monolithic - Mouser 21 RX510
- .02uF monolithic - Mouser 21 XR420
- 0.1 uF monolithic - Mouser 21 XR310

(Optional) 5-Pin .025" Rt-Angle PC-Mtg Shrouded

(male) Header connector, Mouser 571-1033613, mating plug is with Mouser 571-1022413 (this mating plug, requires five 571-875236 female receptacles).

You may find it helpful to have a couple single-pin connectors for the DC and the KEY IN lines as well. Mouser 571-7874992 single-pin housings (with 571-875236 receptacles) mate with 571-1021073 push-in pin or with a single pin from Mouser 517-6111 TN.

* Starting value, Cv & CT must be found by trial and error. Start with .001 uF at Cv and increase if non-QSK keying needs to be heavier.

For CT, start with .02uF-.022uF and about 500k for RT. Or use a 1 M pot at RT and adjust it until the proper weighting is achieved. Then replace the pot with a fixed resistor of equal value. Note that pads are also provided for a permanently mounted trimpot (Mouser 72-T7RYB-1 M or 594-75H-1 M), if you wish to replace RT with a variable device altogether.

TS-950 users note: You *must* connect to a +15VDC supply line, rather than to a +5VDC line. Otherwise, the VOX/T-R line may trigger falsely. This mod must be used with an AUX Key input (see: <http://www.k6xx.com/radio/auxkeyin.pdf>). Finally, this mod will NOT function in the TS950 series unless a 1/4" stereo phone plug (empty or otherwise) is installed in the KEY jack on the back panel of the radio.

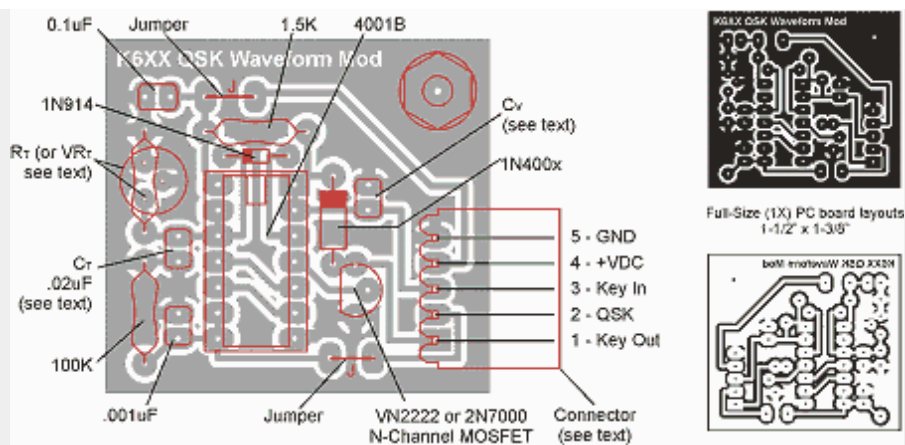

Foil-Side of PC board, showing X-Ray view of component placement. All components mount on the NON-FOIL side of board.

PC board design by: Tom Hammond, NOSS 03/18/2001

This modification can also be [download](#) (2.5 Mb) as a PDF file by Tom Hammond NØSS

This modification is read 216 times.

[top of page](#)

22-03-2002

(TS-950) TS-950 SO2 Adjust

Author: Dave, W6NL/HC8L - leeson@earthlink.net.MODIFICATION.NET

The TS-950SDs I have use the Kenwood TCXO SO2. They have both drifted off frequency enough to notice, so I wanted to reset the master oscillators.

The frequency adjustment is under the TCXO label (under the "N" in Kenwood). I peeled back the label, and the adjustment was simple. I tune in WWV at frequency = 20.000 MHz, mode = AM, filters = 6 kHz, marker = on.

You can hear the beat note and adjust for zero beat. I assume I'm the only one that didn't know about this!

73 de Dave, W6NL/HC8L

This modification is read 42 times.

[top of page](#)

28-03-2002

(TS-950) Using Subreceiver to Improve TS-950 Noise Blanker

Author: Dave Leeson, W6NL/HC8L - leeson@earthlink.net.MODIFICATION.NET

I was searching for a way to blank ac line noise without getting the distortion and intermodulation you get when you use the typical transceiver noise blanker. I was researching Collins 316B-2 (uses 40 MHz noise receiver) and ac line-synchronous blankers and was looking at the TS-950 blanker circuit to see how it was implimented when I realized that either the main or subreceiver can trigger the NB diodes for both receivers. So this meant I could use the subreceiver to get the noise signal, and it could be tuned to a quiet part of the band (or even out of band).

By inspection of the circuit diagrams in the service manual, it appears that the noise blanker function can be driven by either the main or subreceiver signal, but that in either case the blanking is applied to both paths. So one can turn on the subreceiver, tune it to a quiet spot in or out of the active band, and use the subreceiver blanking control rather than the main blanking control to get impulse blanking without distortion or intermodulation from in-band signals.

To set up:

- NB1 = ON
- Main NB = minimum (full CCW)
- Sub NB = set for blanking
- Sub RX = ON
- Sub RX frequency = out of band

This results in quiet, intermod free blanking.

The only problem seems to be a limitation on the spacing between the main and sub receiver frequencies of 500 kHz maximum, but

this isn't a big issue. You can listen to the subreceiver output to confirm that there isn't an interfering signal there.

For information on powerful ac line-synchronous blankers, see

http://www.ussc.com/~turner/syn_blank.html http://www.ussc.com/~turner/syn_blank.html

<http://www.ussc.com/~turner/BLANKER1.GIF> <http://www.ussc.com/~turner/BLANKER1.GIF>

<http://www.lwca.org/library/articles/jtreed/gate/gate1b.htm> <http://www.lwca.org/library/articles/jtreed/gate/gate1b.htm>

These are blankers that use the AC line itself to set phase and blanking width, and are used with VLF receivers where line noise can be a big problem.

This modification is read 1 times.

[top of page](#)

19-07-1998

(TW-4000) Umbau des Kenwood TW4000A für den Betrieb mit 9600 Baud Modem G3RUH

de DB8YP @ DB0IZ

Diese Umbauanleitung bezieht sich nur auf den Anschluß des Modem nach G3RUH, andere Modem werden möglicherweise auch funktionieren aber es wurde nicht getestet.

Die Informationen für den Umbau habe ich von OM Otto DK8KQ.

Sie benötigen:

Den Schaltplan

Ein DIL Relais 5v oder equivalent; nicht größer als ein DIL Relais und Betriebsspannung zwischen 5 und 10 Volt. (12 Volt geht manchmal auch)

Einen Widerstand ca (330-440 Ohm)

Einen mittleren Kreuzschlitzschraubendreher

Einen Elektroniklötkolben

Elektroniklot mit Flußmittel

Wenn Sie die vorhandene Zusatzbuchse an der Rückseite des Gerätes für den Anschluß des Modem verwenden wollen, sollten Sie einmal nach dem kleinen runden Stecker mit den vier (noch kleineren) Stiften fahnden. Er war bei der Orginallieferung. Falls Sie Ihn nicht mehr finden oder falls Sie den Anschluß des Modems mittels des Mikrofon-steckers durchführen wollen suchen Sie nicht weiter.

1. Markieren der Anschlußpunkte im Schaltplan.

a) Lokalisieren Sie im Schaltplan IC1 auf der Platine 'RX-TX-UNIT' Dieses befindet sich im unteren linken Drittel. Das IC hat 27 Anschlüsse. Pin 13 ist derjenige, an dem das demodulierte Empfangs- signal abgegriffen wird. Es wird entweder zur Microfonbuchse Pin 6 geführt oder zur Zusatzbuchse. (Den Pin können Sie sich aussuchen)

b) Von IC1 rechts herüber, etwa in der Mitte der Schaltung finden Sie einen dicken Signalweg mit R94 und C187. Dies ist der Einspeisepunkt des Modemsignals, es geht dierekt in den Modulator.

Das Modemsignal kann allerdings nicht ohne Umweg in den Modulator eingespeist werden, damit die Modulationsdiode nicht während des Empfangs durch das Modemsignal verstimmt wird, muß das Modem- signal duch ein Relais währen des Empfangs abgetrennt werden!.

2. Gehäuse öffnen.

Trennen Sie alle externen Anschlüsse am TW4000A ab, entfernen Sie die je 4 Schrauben, die den oberen und unteren Gehäusedeckel am Chassis 'festhalten' (Eine dieser Schrauben befindet sich an der Rückseite des Gehäuses in der Mitte des Kühlkörpers am oberen und unteren Rand. Die anderen drei sind vorne in der Mitte und an den Seiten.

Nach Entfernen der Schrauben die Deckel erst etwas nach hinten schieben und dann abheben.

Anmerkung. Sie brauchen den oberen Deckel nicht zu entfernen, wenn Sie den Anschluß über die Mikrofonbuchse planen. Soll jedoch die Zusatzbuche an der Rückseite benutzt werden, so muß auch die obere Abdeckung entfernt werden.

3. Relais Einbau

Legen Sie das Gerät auf den Rücken, Sie sollten jetzt vorne rechts einen kleinen Bereich sehen, der durch Weissblech 'eingezäunt' ist, etwa 3.5 mal 2 cm groß. Falls Sie nichts finden, schrauben Sie alles schnell wieder zu, dann haben Sie das falsche Gerät erwischt.!

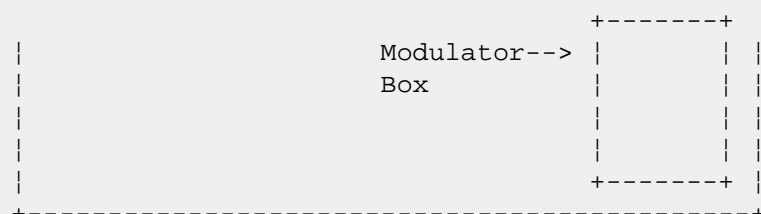

+----+ Freq. ---> | |
 Mike Knopf +-----+

Sie können das DIL Relais nun mit den Anschlüssen 9 und 13 an den Weißblechrahmen anlöten, diese Pins sind nach meiner Kenntnis nicht belegt, wenn Sie ein anderes Relais verwenden, suchen Sie sich zwei nicht belegte Pins aus um sie anlöten zu können, Sind keine Pins zu finden, so muß der gute alte Heißkleber ran.

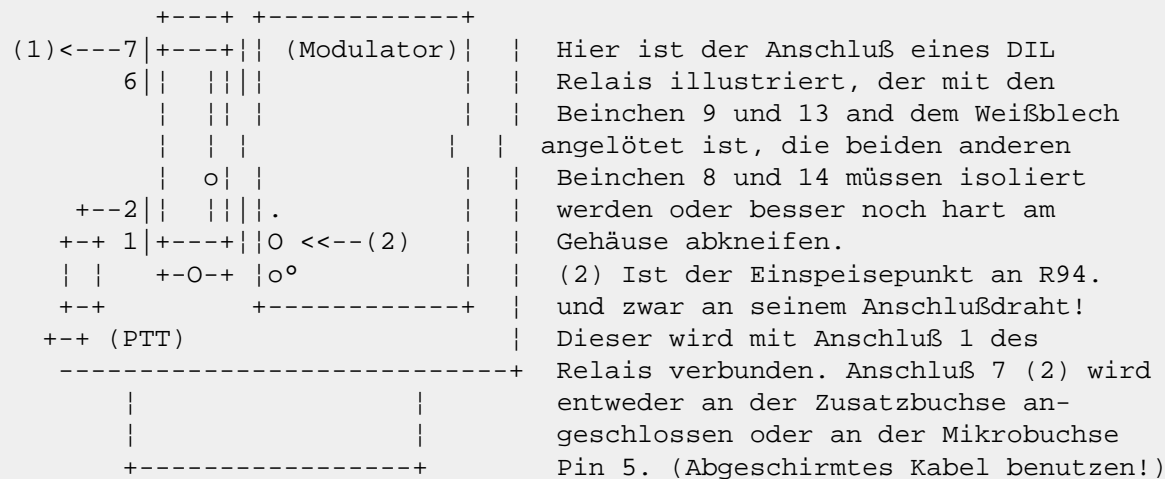

Pin 6 des Relais wird quer über das Gehäuse mit Pin 9 (Masse) verbunden.

Pin 2 über 330-440 Ohm an (8T). Dieses Signal findet man an dem Stecker 6 (4 fach) am vorderen Rand der Hauptplatine. Am besten ist es, 8T vom Stecker ausgehend auf die Platine zu verfolgen (Richtung D17) so findet man einen großen freien Platz mit einigen Lötunkten, dort kann man genüsslich löten.

Achtung: Bitte sorgfältig nachsuchen und kein anderes Signal verbiegen. Ist die PTT betätigt, so liegt an diesem Signal ca 8V an, sonst 0V.

4. Empfangssignal

Dieses wird von IC1 Pin 13 abgenommen. IC1 'steht' quer auf der Haupt- platine am vorderen Rand:

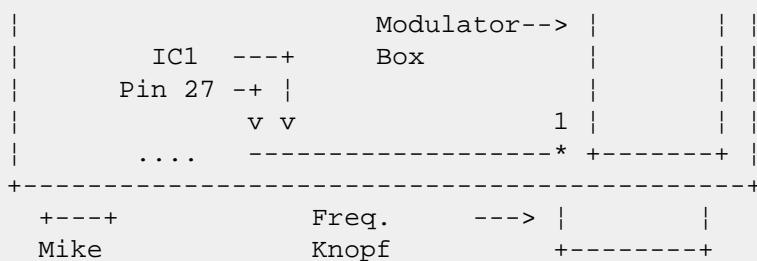

Wenn man vom linken Rand des IC's (pin 1) langsam nach links zählt bis 13 ! (kann ja jeder Funkamatuer hi) so hat man den Anschluss- punkt. Mit feiner Spitze und ruhiger Hand kann man hier den Draht anlöten, der entweder zu Mike Buchse Pin 6 führt oder zur Zusatz- buchse.

5. Mike Buchse:

Haben Sie sich für die Mike Busche entschieden, so können Sie die Anschlüsse 5 und 6 benutzen, Die bestehenden Anschlüsse müssen natürlich entfernt werden. Sie haben den Vorteil, daß das PTT Signal gleich vorhanden ist und der Anschluß vor vorne geschieht.

6. Zusatzbuchse.

An der Rückseite befindet sich eine vierpolige Zusatzbuchse, ich habe diese für den Anschluß des Modem verwendet. Zusätzlich zu NF und Mike-In muß dann aber noch das PTT Signal von der Mike Buchse nach hinten geführt werden.

7. Fertig.....

Noch nicht ganz, Ist alles angeschlossen und die Verbindung zum Modem herstellt, so sollte der Modulationshub noch eingestellt werden.

Die erste Probe wird natürlich sein: Empfängt das Modem überhaupt etwas ? Wenn ja, ist das meiste schon getan, anderenfalls nochmal alle Verbindungen prüfen und noch einmal bis 13 zählen, von links bitte !

Wenn Sie nun die PTT betätigen, so muß das Relais anziehen, falls nicht, haben Sie nicht das Signal 8T gefunden, oder der Wieder-stand hat 440KOhm statt 440 Ohm ! (orange orange braun)

Wenn das Relais angezogen hat, sollten Sie das Modulationsignal an R94 feststellen können (Hochohm Kopfhörer geht auch)

Den Modulationshub habe ich nach einem Tip von DK8KQ mit einem Kontrollempfänger so eingestellt, daß bei aufgedrehtem Squelsh des Kontrollempfängers das Sendesignal des TW4000A kaum noch vom Hintergrundrauschen des Empfängers zu unterscheiden war.

Als ich dann noch nach einigen Tagen herausgefunden hatte, daß mein 9600'er Netzeinstieg mit Ablage arbeitet könnte ich endlich auch feststellen, daß der Sendeteil ordentlich funktioniert.

Viel Glück beim Umbau,

73, de DB8YP

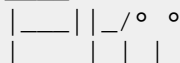
Peter, Korschenbroich 3 

This modification is read 600 times.

[top of page](#)

19-07-1998

(TW-4000) Kenwood TW-4000 for CAP

On the back of the CPU assembly, (part of the front panel assembly), there is a wire jumper (sort of a loop of wire between two pads on the board). If you clip this wire, and reset the CPU, the '4000 will RX-TX from 141.0 Mhz to 150.995 Mhz. There is no change on UHF.

Keith McQueen, Wicat Systems Inc. , (801)224-6400

Packet: n7hmf @ nv7v.UT.USA.NA

Internet: keithm@wicat.com

This modification is read 755 times.

[top of page](#)

19-07-1998

(TW-4100) Modificatie KENWOOD TW-4100E voor subtone

Door ON5OF, Dirk Van Offel

*Deze modificatie laat toe ALLE mogelijkheden van de dualbander ONGEWIJZIGD te behouden, INCLUSIEF 1750 Hz repeaterton, vanaf frontpaneelknop "SQL" De TONE toets wordt dan Subtone ON/OFF, en de toon wordt ingesteld via SEL- menu (zoals de shift, de step enz.). Subtone is ALLEEN TX, geen RX. De nodige Unit is de TU-7, standaard in België door Kenwood leverbaar. De verbindingkabel is NIET die van de TU-7, maar degene die ORIGINEEL bij de TW4100 E is (ai voor diegenen die deze "ergens" mislegd hebben).

Procedure

- open toestel Boven/onderdeksel/ 4 vijzen van frontpaneel
- installeer TU-7 zoals p. 31 tw4100 instruction manual, met de lange verbin- dingskabel, standaard geleverd bij toestel.
- knip Diode D3 op de control unit x53-3000-xx gelegen juist boven display, de eerste diode van links.
- localiseer connector CN9, met 1 blauwe draad op rint x60-3000 composite unit, herkenbaar aan het gat voor de magneet van de speaker. Hij (CN9) zit rechts opzij, heeft 2 pinnen waarvan 1 bestukt (blauwe draad) ongeveer 3 cm vanaf de voorzijde van de print, achter de input TOKO's van RX144 IN.
- volg de blauwe draad naar het frontpaneel en knip hem door, dichtbij CN8 van frontpaneelunit, isoleer met krimpkous de zijde die naar de brede connector (12 polen) CN7 van de frontpaneelunit (controlunit x53-3000-xx).
- de andere kant van de blauwe draad solderen we aan de zwarte massa-draad, komende van de "push"schakelaar in de squelchknop (voice switch) die wordt dan 1750 i.p.v. voice. Zo zetten we 5 volt op de 555 om 1750 hz te maken als we, met de ptt ingedrukt op de squelch duwen.
- de zwarte massadraad komt van de squelchknop en gaat naar uiterste rechtse zijde, positie 4 GND van CN8, ligt juist rechts naast een rode draad (in de richting van de opdruk "CN8", dus met de onderzijde van het toestel naar boven microplug links, en voorzijde frontpaneel naar onder)
- knip de zwarte draad van CN8 op 2 cm van de connector CN8 en isoleer die zijde van de draad die naar de connector gaat.
- de andere zijde dus vast solderen aan de blauwe draad naar CN9 op de andere print x60-3000-xx, eerst isoleerkous erover!!
- en de modificatie is klaar!!. Toestel nog dichtschoeven en RESET de micro- processor (hold "M" on power ON). Als U een DCL unit hebt, laat de processor weten dat er een inzit (hold "DCL" on power ON).

VEEL SUCCES EN TE HOREN OP ON0ZK 145.637,5 subtone 173.8 Hz
en op ON0HOB 430.250 subtone 131.8 Hz

from the only serious EME station on 70cm in Belgium, yours truly servant,
Dirk, ON5OF

This modification is read 556 times.

[top of page](#)

19-07-1998

(TW-4100) BandMod for TW4100

The following modification will allow the TW-4100A to transmit on the VHF band from 141-151 and on the UHF band from 420 to 450 MHz.

1. Disconnect the antenna, mic, and power cord.
2. Remove the top and bottom covers from the transceiver by following the procedure on page 28 of the Instruction Manual.
3. Locate the row of diodes on the control unit (top front). The diodes can be seen by looking through the cutout in the chassis just behind the front panel.
4. Using a sharp pair of wire cutters, cut diodes D6 (UHF) and D8 (VHF). Note that diodes D3, 4, 5, and 7 are already removed.
5. Reinstall the top and bottom covers.
6. Reset the microprocessor by turning on while pushing the M button.

This modification is read 652 times.

[top of page](#)

16-04-2000

(TW-4100) TW-4100 repeater stop scan on the UHF band

Author: Trio-Kenwood Communication, inc.

Service Bulletin no. 926 (17-12-1987)

During repeater cross band operation, the TW-4100 may not detect a UHF signal while it is alternating between the two bands. This is due to the electric field generated by the strong UHF receiving signal causing the busy circuit to malfunction. The following modification will allow detection of the UHF signal.

Parts required:

(1) Resistor 4.7 Kohm 1/8 watt	RD14BB2B472J
(1) Capacitor, electrolytic 4.7 μ F, 16V	CE04CW1C4R7M
(1) Diodes 1S1555	V11-0076-05

1. Remove the 4 screws securing the top cover.
2. Remove the 10 screws securing the bottom cover.
3. Carefully remove the top and bottom covers. Do not damage the speaker cable attached to the bottom cover.

Refer to figure 1 for the next 3 steps.

4. Locate connector number 12 on the Composite unit (RX-TX) on the bottom of the transceiver.
5. Carefully strip 1/8 inch insulation from wire attached to pin 2 connector 12 approximately 1/4 inch from the connector (do not break the wire).
6. Solder the 3 components (listed above) between the wire and ground. A good ground location is the can around TC2 and L8.
7. Assemble the transceiver by reversing steps 1 - 4.

Figure 1.

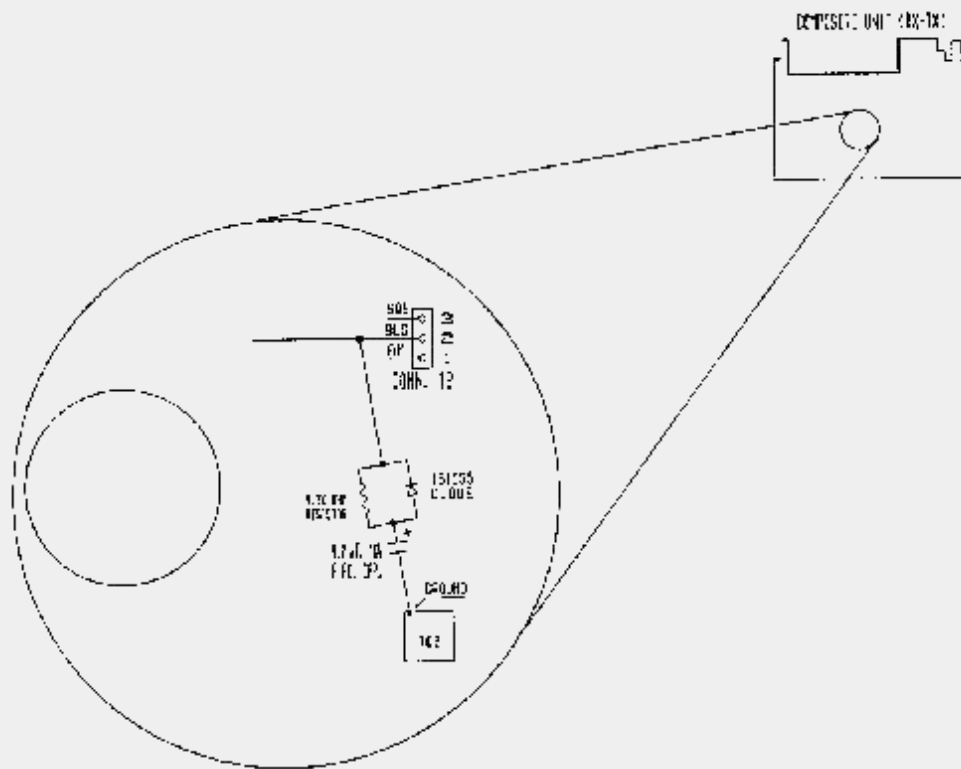

This modification may be covered under warranty.
Time required for this modification is ½ hour or less.

This modification is read 557 times.

[top of page](#)

09-04-2000

(VFO-120) VFO-120 Dial Lamp Switching Circuit

Author: Trio-Kenwood Communication, inc.

Service Bulletin no. 862 (14-4-1982)

When operated with a TS-130 series transceiver, the dial lamp on the external VFO will remain on if the power supply remains on, even through the transceiver is off. Adding a transistor switch on the VFO-120 switch unit X41-1240-00 will provide automatic lamp operation from the transceiver power switch.

On the Switch unit, add transistor Q1 2SC1959(Y) (V03-1959-06) as a pilot light ground switch, controlled by the transceiver 9V DC line. Connect Q1 emitter to ground, collector to the pilot light ground (either the lead, or connector CJ-2, pin 2) and base through a 4.7 Kohm resistor (R9) (RD14CB2E472J) to the 9V line.

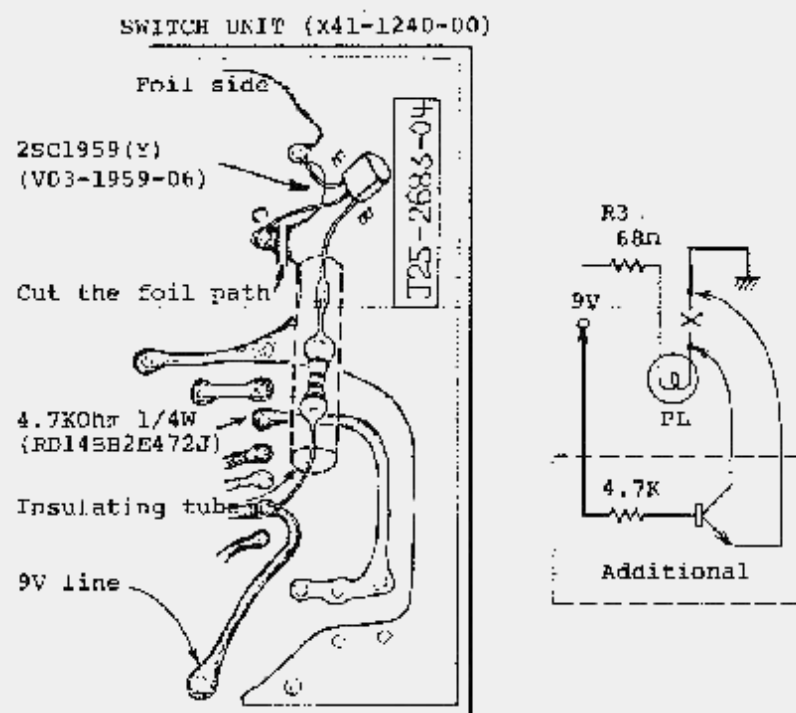

Note:

1. This change may be applied to units before serial number 110001.
2. Installation time for this procedure is ½ hour or less.

